

**VERITAS REGISTER OF SHIPPING**

---

**RULES FOR THE CLASSIFICATION AND  
CONSTRUCTION OF SEAGOING SHIPS**

**Part I  
Classification**



**BATUMI 2024**

Veritas Register of Shipping Ltd

**Rules for classification and construction of seagoing ships**

**Part VI Fire Protection**

These Rules developed on the basis of the Rules for classifications and constructions of seagoing ships on Ukrainian Register of Shipping with taking into account the experience of their application, changes in the applicable International conventions, Codes and Resolutions adopted by the International Maritime organization (IMO) with applicable amendments and changes in the applied resolutions of the United Nations Economic Commission for Europe and directives of the European Parliament and Council.

Rules for classification and construction of sea-going ships consist of following parts:

Part I Classification

Part II Hull;

Part III Equipment, Arrangements and Outfit;

Part IV Stability;

Part V Subdivision;

**Part VI Fire Protection;**

Part VII Machinery Installations;

Part VIII Systems and Piping;

Part IX Machinery;

Part X Boilers, Heat Exchangers and Pressure Vessels;

Part XI Electrical Equipment;

Part XII Refrigerating Plants;

Part XIII Materials;

Part XIV Welding;

Part XV Automation;

Part XVI Structure and Strength of Fiber-Reinforced Plastic Ships;

Documents have been approved in accordance with the established approval procedure and come into force on 1<sup>st</sup> July of 2024.

The Rules are published in English. Official version of Rules for classifications and constructions of seagoing ships located on the official web site of Veritas Register of Shipping on the link <https://vrsclass.com/>

Official edition of the Veritas Register of Shipping

© **Ukrainian Register of Shipping**



## PART VI. FIRE PROTECTION

### 1. GENERAL

#### 1.1 APPLICATION

**1.1.1** The requirements of the present Part of the Rules apply to ship's structural fire protection, fire extinguishing systems and fire detection and alarm systems, as well as fire-fighting equipment and outfit.

**1.1.2** The fire protection requirements relating to the structural items of the ship hull, machinery and parts thereof, electrical equipment, pumping and piping, ship's arrangements, fuel oil and lubricating oil tanks, construction and location of boilers, refrigerating plants, ship's spaces, etc. are set out in the relevant parts of the Rules.

#### 1.2 DEFINITIONS AND EXPLANATIONS

The definitions and explanations relating to the general terminology of the Rules are given in General Survey Regulations and Part I "Classification" of the Rules for the classification and construction of ships<sup>1</sup>.

The following definitions have been adopted in this Part of the Rules:

*Atriums* are public spaces within a single main vertical zone spanning three or more open decks.

*Cabin balcony* is an open deck space which is provided for exclusive use of the occupants of single cabin and has direct access from such a cabin.

*Continuous "B" class ceilings or linings* are those "B" class ceilings or linings which terminate at an "A" or "B" class division.

*Adjacent compartments or spaces* are those compartments or spaces which are separated from one another by a bulkhead, deck, platform, or any other fixed division without openings or with openings provided with means of closure.

Compartments or spaces continuous to one another at the corners only are not considered as adjacent.

Compartments and spaces separated from one another by removable divisions (i.e. those removable under normal service conditions) or having openings not fitted with means of closing, in the bulkhead or deck that separates them, are considered as one single space.

*A standard fire test* is a test in which the relevant specimens are exposed in a test furnace to temperatures corresponding approximately to the time-temperature curve in accordance with the test method specified in the FTP Code 2010.

*Smothering* is filling of a protected space with a medium not supporting combustion.

*Surface extinction* is cooling, wetting or restriction of oxygen access to burning surfaces.

*Fire-fighting outfit* is portable fire-fighting equipment (apparatus, appliances, consumable materials) intended for:

fire extinction; ensuring effective fire-fighting actions of the crew;  
ensuring operation of fire extinguishing systems.

*Water mist lance* – means a tube with a piercing nozzle which is capable of penetrating a container wall and producing water mist inside a confined space (container, etc.) when connected to the fire main.

*Structural fire protection* is a complex of the passive means of structural fire protection intended for:

prevention of fire; containment of flame and smoke spreading throughout the ship;  
creation of conditions for safe evacuation of people from the ship's spaces and from the ship, as well as for effective fire extinction.

*Safe area* perspective of habitability, any area(s) which is not flooded or which is outside the main vertical zone(s) in which a fire has occurred such that it can safely accommodate all persons on board to protect them from hazards to life or health and provide them with basic services.

*Code on Alerts and Indicators* means the Code on Alerts and Indicators, as adopted by IMO resolution A.1021(26).

*IGC Code* - The International Code for Construction and Equipment of Ships Carrying Liquefied Gases in Bulk revised in accordance with IMO Resolution MSC.370 (93), as amended by Resolutions MSC.411 (97) and MSC.441 (99).

<sup>1</sup> Hereinafter referred to as Part I “Classification”.

*IGF Code* - The International Code of Safety for Ships using gas or other low-flashpoint fuels (IGF Code) 2015, adopted by IMO Resolution MSC.391 (95), as amended, including by IMO Resolution MSC.458 (101).

*IBC Code* - International Bulk Chemical Code (IBC Code) The International Code for the Construction and Equipment of Ships Carrying Dangerous Chemicals in Bulk 1994, as amended, including by IMO resolution MSC.460 (101).

*Fire Safety Systems Code* – means International Code for Fire Safety Systems, as adopted by the IMO Maritime Safety Committee by IMO resolution MSC.98(73) as amended by IMO resolution IMO MSC.457(101).

*Fire Test Procedures Code* means the International Code for Application of Fire Test Procedures, 2010 (2010 F T P C o d e), as adopted by the IMO Maritime Safety Committee by resolution IMO MSC.307(88) as amended by IMO resolution IMO MSC.437(99).

*IMDG Code* – International Maritime Dangerous Goods Code, adopted by IMO Resolution MS.406 (96), as amended, including by IMO Resolution MSC.442 (99).

*IMSBC Code* – International Maritime Solid Bulk Cargoes (IMSBC) Code, adopted by IMO Resolution MSC.268 (85), as amended, including by IMO Resolution MSC.462 (101).

*MARPOL-73/78/97<sup>2</sup>* – The International Convention for the Prevention of Pollution from Ships, 1973, as modified by the Protocol of 1978, (MARPOL-73/78) as amended by the Protocol of 1997 (MARPOL-73/78/97).

*SOLAS-74/78/88<sup>3</sup>* – The International Convention for the Safety of Life at Sea 1974 as modified by the Protocols of 1978 and 1988 thereto, including applicable codes.

*Nominal foam expansion ratio* is the ratio of the volume of foam to the volume of foam solution from which it was made, under non-fire conditions, and at an ambient temperature of e.g. around 20°C.

*Independent pump drive* is a pump drive from a separate electric, hydraulic or diesel engine, intended solely for the operation of the pump.

*Lower flammable limit (LFL)* is minimum concentration of oil gases and vapours in air capable of igniting from a source of ignition and propagating combustion in the mixture.

*Fire-fighting equipment and systems* are those active means of fire protection which are intended for fire extinction and containment of fire spreading throughout the ship.

*Primary deck covering* is the first layer of a floor construction, which is applied directly on top of the deck plating and is inclusive of any primary covering, corrosion-resistant compound or adhesive, which is necessary to provide protection or adhesion to the deck plating. Other layers of a floor construction, which are applied directly on top of the deck plating, constitute floor coverings.

*Foam delivery ducts* are supply ducts for introducing high expansion foam into the protected space from foam generators located outside the protected space.

*POLAR Code<sup>4</sup>* – The International Code for Ships Operating in Polar Waters 2014, adopted by IMO Resolutions MSC.385(94) and MEPC.264(68), having regard to the provisions of the amendments to the international SOLAS-74/78/88, adopted by Resolution MSC.386(94).

*Casualty threshold* in the context of a fire includes:

- loss of the space of origin up to the nearest “A” class boundaries, which may be a part of the space of origin, if the space of origin is protected by a fixed fire extinguishing system; or
- loss of the space of origin and adjacent spaces up to the nearest “A” class boundaries which are not part of the space of origin.

*Fire control station* is a control station where items of fire detection and fire alarm systems or control of fire extinguishing systems are centralized.

*Protected space* is a space equipped with one of the fire extinguishing systems or with an automatic fire detection system.

*Rooms containing furniture and furnishings of restricted fire risk for the purpose of application on ships carrying more than 36 persons* – are the rooms (whether cabins, public spaces, offices or other types of accommodation referred to in **1.5.2**) in which:

<sup>2</sup> Hereinafter — MARPOL-73/78/97.

<sup>3</sup> Hereinafter — SOLAS Convention as amended.

<sup>4</sup> Hereinafter — POLAR Code.

all furniture, such as desks, wardrobes, dressing tables, bureaux, dressers, is constructed entirely of approved non-combustible materials, except that a combustible veneer not exceeding 2 mm in thickness may be used on the working surface of such articles;

all free-standing furniture, such as chairs, sofas, tables, is constructed with frames of non-combustible materials;

all draperies, curtains and other suspended textile materials have qualities of resistance to the flame spread not inferior to those of wool of mass 0,8 kg/m<sup>2</sup>, this being determined in accordance with the FTP Code;

all floor coverings have low flame spread characteristics;

all exposed surfaces of bulkheads, linings and ceilings have low flame spread characteristics;

all upholstered furniture has qualities of resistance to ignition and flame spread, this being determined in accordance with the FTP Code;

all bedding components have qualities of resistance to ignition and flame spread, this being determined in accordance with the FTP Code.

*Ray* – a group of automatic and manual detectors identified in the alarm panel of the fire detection alarm system.

*Fire damper, smoke damper* is a device installed in a ventilation duct, which in the normal position is open and allows air flow in the middle of the duct.

In case of fire, the fire damper closes and prevents air from flowing inside the duct, thereby preventing from flame propagation through the ventilation duct.

Fire dampers may have the following definitions:

.1 automatic fire damper - a fire damper that closes automatically under the action of combustion products;

.2 manual fire damper – a fire damper that opens and closes using manual controls in place;

.3 remote control fire damper - a fire damper that is closed by means of controls located remotely from this damper.

The smoke damper closes in the event of a fire and prevents air from flowing inside the duct, thus preventing from the distribution of smoke and hot gases through the ventilation duct; it is not believed that the smoke damper will provide the integrity of the fire-resistant grillage through which the ventilation duct passes.

Smoke dampers may have the following definitions:

.1 automatic smoke damper – a smoke damper that closes automatically under the action of combustion products;

.2 manual smoke damper – a smoke damper that opens and closes using manual controls in place;

.3 remote control smoke damper – a smoke damper that is closed by means of controls located remotely from this damper.

*Flammable liquids* are liquids, or mixtures of liquids, or liquids containing solids in solution or suspension (e. g. paints, varnishes, lacquers, etc.) which give off flammable vapours at or below 60°C closed cup test.

*Rated volume of a protected space* is the gross volume of a space bounded by water-tight or gastight bulkheads and decks with the deduction for the volume occupied by main machinery reduction gear, auxiliaries, boilers, condensers, evaporators, tanks, ventilation and exhaust gas piping.

*Sauna* is a hot room with temperatures normally varying between (usually 80 to 120 °C) where the heat is provided by a hot surface (e. g., by electrically-heated oven). The hot room may also include the space where the oven is located and adjacent bathrooms.

*Combustible medium* is flammable liquids; flammable gases, compressed, liquefied or dissolved under pressure; solid combustible materials and substances, including cargoes, fuel, finishing materials, equipment, insulation, furniture.

*Crude oil* means any oil occurring naturally in the earth whether or not treated to render it suitable for transportation and includes crude oil from which certain distillate fractions may have been removed and crude oil to which certain distillate fractions may have been added.

*Inside air foam system* is a fixed high expansion foam fire extinguishing system with foam generators located inside the protected space and drawing air from that space.

*Outside air foam system* is a fixed high expansion foam system with foam generators installed outside the protected space that are directly supplied with fresh air.

*High expansion foam fire extinguishing systems* are fixed total flooding extinguishing systems that use either inside air or outside air for aeration of the foam solution. A high expansion foam system consists of both the foam generators and the dedicated foam concentrate approved during the fire testing specified in 3.7.3.1.1.

*Water-screen systems* are systems which create a water barrier in the form of sufficiently thick curtain of water fed through spray nozzles. Such systems are fitted where the use of "A" class divisions is impracticable.

*Water drenching systems* are those systems which supply water onto vertical or horizontal ship's structures.

*Fixed fire extinguishing systems* are those systems which are intended to supply fire extinguishing medium to the protected spaces or directly therein and structurally fixed to the ship's hull.

*A system equivalent to a deck foam system for cargo tanks* is a system which shall be capable of extinguishing spill fires, precluding ignition of spilled oil not yet ignited and fire extinction in ruptured tanks.

*Steel or other equivalent material* means any non-combustible material, which by itself or due to insulation provided, has structural and integrity properties equivalent to steel at the end of the applicable fire exposure during a standard fire test (e. g., aluminium alloy with appropriate insulation).

*Vehicle carrier* means a cargo ship which only carries cargo in ro-ro spaces or vehicle spaces, and which is designed for the carriage of unoccupied motor vehicles without cargo, as cargo.

*Flash point* is the temperature in degrees Celsius (closed cup test), at which liquid will give off enough flammable vapours to be ignited as determined by an approved flash point apparatus.

*Motor vehicle without fuel in its tanks* is motor vehicle, motor bike, tractor, etc., powered with an internal combustion engine and having empty fuel system and fuel tanks, as well as both battery leads disconnected from the accumulator.

*Fuel oil units* refer to definition given in 1.2, Part VII "Machinery Installations".

*Safety centre* is a control station dedicated to the management of emergency situations. Safety systems operation, control and/or monitoring are an integral part of the safety centre.

*Central control station (CCS)* control and indicator functions are centralized:

- fixed fire detection and fire alarm systems;
- automatic sprinkler system, fire detection and alarm systems, as well as remote starting controls of other fire extinguishing systems;
- fire door indicator panels;
- fire door closures;
- watertight door indicator panels;
- watertight door closures; ventilation fans;
- general/fire alarms; ship communication systems including telephones; and
- microphones for public address systems.

### 1.3 SCOPE OF SURVEYS

**1.3.1** General regulations for the classification, survey of ships under construction and classification surveys, as well as the requirements for the documentation to be submitted to the Register for review are set out in General Survey Regulations and in Part I "Classification".

**1.3.2** Subject to the Register survey during construction of a ship are: structural fire protection, materials used for the interior finishing of ship's spaces, as regards fire hazardous properties thereof, fire extinguishing, fire detection and alarm systems subject to the provisions of the present Part.

As regards fire-fighting outfit, it shall only be checked for correct location and for complete availability in accordance with the requirements of the present Part and availability of documents for materials, fire extinguishing, fire detection and alarm systems approved by Register.

**1.3.3** documents on fire tests run by competent bodies, confirming the efficiency of newly applied fire extinguishing medium with the recommended standards on composition and application rates, as well as information on storage life and conditions;

**.2** reports of the recognized laboratories on the fire tests of "A" and "B" class fire-fighting divisions, closures of openings and passages (cutouts) in such divisions ("A" and "B" class doors included) (refer to 1.6);

**.3** drawings of fire-fighting divisions together with the protocols of the recognized laboratories on tests, which confirm their compliance with "A" and "B" class divisions;

.4 reports of the recognized laboratories on tests of the fire hazardous material features (refer to 1.6);

.5 drawings for individual standard assemblies (equipment) of fire extinguishing systems and fire-fighting outfit;

.6 required calculations, which confirm the fulfillment of the requirements of the present Part.

**1.3.4** After repair, revamping, and modification and associated changes in equipment, all ships shall at least comply with the requirements with which they complied before.

Such ships, if constructed before July 1, 2012, shall usually comply with requirements for ships constructed on and after this date, at least to the same extent as before the implementation of the repair, revamping, modification, or change in equipment.

After the repair, revamping, and modifications that significantly alter the size of the ship or accommodation spaces for passengers or significantly increase the life of ships as well as related changes in equipment, such ships shall comply with requirements for ships constructed on or after July 1, 2012 to the extent deemed appropriate and practicable by the Register.

**1.3.5** Passenger ships that carry more than 36 passengers, except ships of a restricted navigation area **C-R3-S**, **C-R3-RS** and **D-R3-S**, **D-R3-RS**, which were modified in accordance with **1.3.4** shall comply with the following requirements:

.1 all materials used in replacements for these ships must comply with requirements to materials used to build new ships; and

.2 all repairs, revamping, modifications, and changes in equipment that include the replacement of materials in the amount of 50 tons or more other than those required to upgrade the ship shall comply with requirements applicable to new ships.

#### **1.4 FIRE PLANS**

**1.4.1** At the central control station, wheelhouse or in conspicuous positions in corridors and lobbies of any ship, there shall be exhibited general arrangement plans clearly showing the following for each deck:

.1 location of control stations;

.2 arrangement of fire-resisting and fire-retarding divisions;

.3 spaces protected by the fire detection and alarm system;

.4 spaces protected by fixed fire extinguishing systems with indication of the location of instruments and fittings for their control and also the disposition of fire hydrants;

.5 means of access to different compartments, decks, etc., with indication of escape routes, corridors and doors;

.6 ventilation system including the controls of fans and showing the disposition of dampers and the identification numbers of the fans serving the groups of spaces, fenced off by fire-resistant boundaries.

.7 arrangement of fire-fighting outfit;

.8 location of the documents referred to in **1.4.6**;

.9 location of emergency escape breathing devices specified in **5.1.23**.

**1.4.2** In lieu of the plans, information specified in **1.4.1** may be set out in a booklet, a copy of which shall be supplied to each officer, and one copy at all times shall be available on board in an accessible position.

**1.4.3** A duplicate set of the plans or the booklet protected against marine environment shall be permanently stowed outside the deck-house in a weather-tight enclosure painted red and marked as indicated in Fig. 1.4.3-1 in compliance with IMO MSC/Circ. 541.

The enclosure shall be capable of being easily opened, be readily available to the shore-side fire-fighting personnel, be located in a well-illuminated position, if possible including illumination from an emergency source.

In oil tankers, chemical tankers and gas carriers the enclosure of fire control plans shall not be located on exterior bulkheads of superstructures which face cargo area and the surfaces within 3 m from them along the side.

If the enclosure is not adjacent to the gangway, there shall be guide signs as indicated in Fig. 1.4.3-2 showing the way thereto.

The dimensions of the signs shall be not less than 300 x 400 mm.

**1.4.4** Description in such plans and booklets shall be in the state language and in the English language. The symbols for items listed in 1.4.1 shall be in agreement with IMO resolution A.952(23)



"Graphical Symbols for Fire Control Plans", as amended by IMO resolution A.1116(30) for ships constructed after 1 January 2019.

For ships not engaged on international voyages, translation into English is not required.  
The graphical symbols shall be coloured.

**1.4.5** All alterations in the fire protection of a ship shall be entered in the ship's documents stated in **1.4.1** and **1.4.2**.

**1.4.6** To be kept in a separate file in an accessible position are technical instructions for maintenance and use of all ship's installations for extinction and containment of fire.

**1.4.7** On passenger ships carrying more than 36 passengers, plans and booklets shall provide information regarding fire protection, fire detection and fire extinction in accordance with **1.4.1** and considering IMO resolution A.756(18).

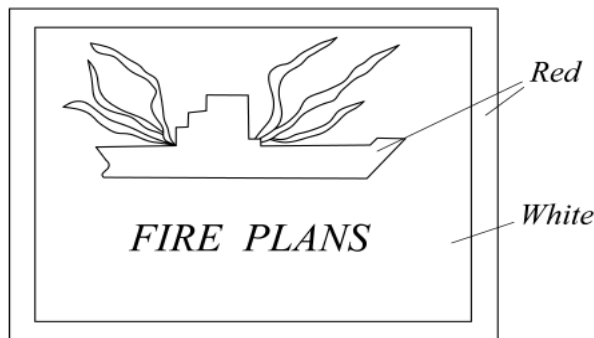

Fig. 1.4.3-1

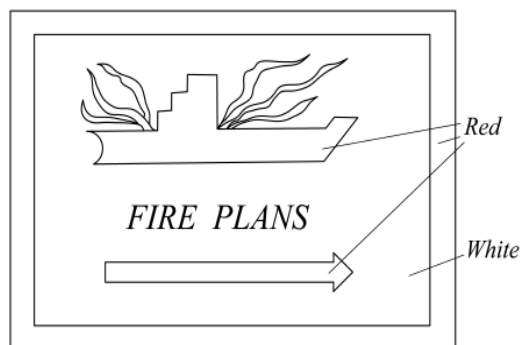

Fig. 1.4.3-2

## 1.5 CATEGORIES OF SHIP'S SPACES

### 1.5.1 Control stations:

**.1** spaces in which the ship's radio or main navigational equipment (in particular: steering stand, compass, radar and direction finding equipment), or the emergency power source, (including accumulator batteries regardless of their capacity, according to Part XI "Electrical Equipment"), or in which items of fire detection and fire alarm systems or control of fire extinguishing systems are centralized.

Steering gear room containing its emergency control is not considered as a control station.

If in the present Part there are no specific requirements for the centralization within a control station of major components of the fixed fire extinguishing systems, then such major components may be placed in spaces, which are not considered as control stations;

**.2** control stations (refer to **1.5.1.1**), which may also be considered as machinery spaces, such as emergency diesel generators rooms;

**.3** spaces containing equipment for the control of submersion, emersion and heeling;

**.4** control stations for fire and rescue operations (refer to **6.6.2**);

**.5** compression chamber control station and diving operation control station whose functions may be combined in one control station (refer to International Code of Safety for Diving Operations, 2023 (2023 Diving CODE)).

### 1.5.2 Accommodation spaces:

**.1** spaces used as cabins, corridors, offices, medical rooms, cinema halls, games and entertainment halls, barbers shops, pantries which are not used for taking meals and do not contain equipment for cooking hot meals (however such pantries may have the following appliances: coffee machines, toasters, dish washing machines, microwave ovens, induction heaters and similar appliances each consuming not

more than 5 kW; electric stoves and kitchen stoves for food heating consuming not more than 2 kW and having a surface temperature of not more than 150 °C), and other similar spaces;

.2 public spaces: the accommodation spaces used as halls, dining rooms, lounges and similar permanently enclosed spaces;

.3 sanitary spaces: the public spaces used as shower-rooms, bathrooms, toilets, small laundries, indoor swimming pools etc.

#### 1.5.3 Service spaces:

.1 service spaces used as galleys (spaces containing electric stoves and kitchen stoves with a capacity of more than 5 kW), pantries containing equipment for cooking hot meals (such pantries may have the following appliances: toasters, microwave ovens and similar appliances each consuming not more than 5 kW; electric stoves and kitchen stoves for food heating consuming up to 5 kW), various workshops not forming part of machinery spaces and similar spaces as well as trunks leading to such spaces;

.2 service spaces used as storerooms:

.2.1 storerooms for explosives;

.2.2 storerooms for flammable materials and substances: paint lockers, spaces for flammable liquids, flammable liquefied and compressed gases, sheltered garages, fuel distribution systems, etc.;

.2.3 storerooms other than mentioned in 1.5.3.2.1 and 1.5.3.2.2;

.2.4 working spaces defined in 1.5.8;

.3 cargo control rooms (refer to definitions in 1.2, Part VII “Machinery Installations”).

#### 1.5.4 Cargo spaces:

.1 cargo tanks intended for the carriage of liquids in bulk, slop tanks included;

.2 spaces for dry cargoes other than ship stores: dry cargo and refrigerated cargo holds and ’tween-decks, including those intended also for carriage of containers and portable tanks, dangerous goods in packaged form or in bulk, motor vehicles without fuel in their tanks; storage spaces for ready produce, utilisable refuse, fishing equipment, packages, etc., as well as produce discharge trunks, cargo lifts and access trunks leading to such spaces;

.3 ro-ro cargo spaces not normally subdivided in any way and extending to either a substantial length or the entire length of the ship, spaces in which motor vehicles with fuel in their tanks for their own propulsion, and/or goods packaged (in tare or in bulk, on rail or road cars, vehicles (including road or rail tanks), trailers, containers, pallets, demountable tanks or similar enlarged units, or other tanks) are normally loaded and unloaded in a horizontal direction. Such spaces are divided into:

.3.1 closed ro-ro cargo spaces which are not spaces specified in 1.5.4.3.2 and 1.5.4.5;

.3.2 open ro-ro cargo spaces either open at both ends, or open at one and provided with adequate natural ventilation effective over their entire length through permanent openings in the side plating or deck-head or from above while the total square of openings shall be at least 10% of the square of side plating of spaces;

.4 vehicle spaces intended for carriage of motor vehicles with fuel in their tanks for their own propulsion, which divide into:

.4.1 enclosed spaces, for vehicles which are not open spaces for vehicles neither weather decks;

.4.2 open vehicle spaces, open similar to 1.5.4.3.2;

.5 weather deck is a deck fully open for environmental exposure from above and at least from two sides. 1.5.5 Machinery spaces — refer to definition of 1.2, Part VII “Machinery Installations”.

1.5.6 Machinery spaces of category A – refer to definition given in 1.2, Part VII “Machinery Installations”.

#### 1.5.7 Pump rooms on tankers and combination carriers:

.1 cargo pump rooms where cargo pumps are located as well as exits and trunks leading to such spaces; pump rooms adjacent to cargo tanks and bilge tanks (refer to 2.4.7);

.2 pump rooms where pumps transporting water and liquid fuel are located.

1.5.8 Working spaces are spaces on special purpose ships, which are neither machinery spaces nor part of them such as workshops, laboratories and other similar spaces, as well as trunks leading to such spaces, where:

.1 fuel oil or flammable liquids are used or combustible materials are processed;

.2 neither flammable liquids are used, nor combustible materials are processed. Working spaces shall comply with the requirements of the present Part for service spaces if not specified otherwise.

1.5.9 Special category spaces are enclosed spaces located above or below the bulkhead deck into and out of which motor vehicles can be driven under their own propulsion and to which passengers have

access. These spaces may be located on more than one deck if total overall clear height for the motor vehicles does not exceed 10 m.

**1.5.10 Special electrical spaces** — refer to 1.2, Part XI “Electrical Equipment.

## **1.6 SUBDIVISION AND TESTING OF MATERIALS AND PRODUCTS ACCORDING TO THE FIRE TEST PROCEDURES CODE 2010**

**1.6.1** The Fire Test Procedures Code is applied to materials and products subject to testing and assessment in accordance with the provisions of the Code and approved by the Register, as required by the Rules.

**1.6.2** Where reference to the Fire Test Procedures Code is made in the text of any requirement of the present Rules, it means that the material or product shall be tested in compliance with an applicable fire test procedure or procedures, stipulated by the Code, except cases specified by the same Code.

**1.6.3** In accordance with applicable parts of Annex 1 of the Fire Test Procedures Code materials and products shall be tested mentioned in the present Rules as:

**.1** non-combustible materials (refer to **2.1.1.5**, **2.1.2**, **2.2.2.5** and **2.3.4**).

Non-combustible material is a material, which neither burns nor gives off flammable vapours in the amount sufficient for self-ignition when heated to 750°C approximately. Any other material is a combustible material. However, products made only of glass, concrete, ceramics, natural stone, masonry units, common metals and metal alloys are considered being noncombustible and may be installed without testing;

**.2** not generating excessive quantities of smoke and toxic products (refer to **2.1.1.7** and **2.1.2.6**) or not hazardous as regards generation of toxic or explosive products at elevated temperatures (refer to **2.1.1.6**);

**.3** “A” or “B” class divisions, such as: decks, bulkheads, doors, continuous ceilings and linings, windows, fire dampers, places of piping and cabling passage (refer to **2.1.2** and **2.1.3**);

**.4** fire doors control systems capable of operating in case of fire (refer to **2.2.4.1.15**);

**.5** low flame-spread surfaces (refer to **2.1.1.5**, **2.1.1.8**, **2.1.2.6**, and **2.1.2.8**). Low flame-spread means that the surface restricts the spread of flame to a sufficient extent;

**.6** draperies, curtains and other vertically supported textile materials, which meet the requirements as regards flame spread resistance not inferior to those of wool having a mass of 0.8 kg/m<sup>2</sup> (refer to **2.1.1.9**);

**.7** upholstered furniture meeting the requirements as regards ignition and flame-spread resistance (refer to **2.1.1.9**);

**.8** bedding components (blankets, covers, pillows, mattresses), which meet the requirements as regards ignition and flame-spread resistance (refer to **2.1.1.9**).

**1.6.4** When testing and approving the materials and products in accordance with the Fire Test Procedures Code additional requirements specified in the appropriate parts of Annex 1 of the Fire Test Procedures Code.

## **1.7 ALTERNATIVE DESIGN AND ARRANGEMENTS**

### **1.7.1 General.**

**1.7.1.1** Fire safety design and arrangements may deviate from the requirements of the present Part, provided, that the design and arrangements meet the fire safety objectives and the functional requirements.

**1.7.1.2** If the design and arrangements deviate from the prescriptive requirements of the present Part, engineering analysis, evaluation and approval of the alternative design and arrangements shall be carried out in accordance with the requirements of the present Chapter.

### **1.7.2 Engineering analysis.**

**1.7.2.1** The engineering analysis submitted to the Register shall be prepared based on the Guidelines on Alternative Design and Arrangements for Fire Safety<sup>5</sup>, and shall include, as a minimum, the following elements:

**.1** determination of the ship type and space(s) concerned;

**.2** identification of prescriptive requirement(s) with which the ship or the space(s) will not comply;

**.3** identification of the fire and explosion hazards of the ship or the space(s) concerned including:

**.3.1** identification of the possible ignition sources;

**.3.2** identification of the potential for the spread of fire of each space concerned;

**.3.3** identification of the smoke and toxic products generation potential for each space concerned;

**.3.4** identification of the potential for the spread of fire, smoke or of toxic products generation from the space(s) concerned to other spaces;

.4 determination of the required fire safety performance criteria for the ships or the space(s) concerned addressed by the prescriptive requirements, which shall:

.4.1 be based on the fire safety objectives and on the functional requirements of the present Part;

.4.2 provide a degree of fire safety not less than that achieved by using the prescriptive requirements;

.4.3 be quantifiable and measurable;

.5 detailed description of the alternative design and arrangements, including a list of the assumptions used in the design and any proposed operational restrictions or conditions;

.6 technical justification demonstrating that the alternative design and arrangements meet the required fire safety performance criteria.

### **1.7.3 Evaluation of the alternative design and arrangements.**

**1.7.3.1** The engineering analysis required in 1.7.2 shall be evaluated and approved by the Register taking into account the Guidelines for Alternative Design Solutions and Means for Fire Safety and Guidelines for Approval of Alternatives and Equivalents Approved by IMO Circular MSC.1/Circ.1455.

**1.7.3.2** A copy of the documentation, as approved by the Register, indicating that the alternative design and arrangements comply with the requirements of the present Chapter shall be carried on board a ship.

### **1.7.4 Re-evaluation due to change of conditions.**

**1.7.4.1** If the assumptions and operational restrictions that were stipulated in the alternative design and arrangements are changed, the engineering analysis shall be carried out again under the changed condition and shall be approved by the Register.

## **2 STRUCTURAL FIRE PROTECTION**

### **2.1 GENERAL**

#### **2.1.1 Requirements for materials.**

**2.1.1.1** The hull, superstructures, structural bulkheads decks and deckhouses shall be manufactured of steel or other equivalent material. For the purpose of using the definition of steel or other equivalent material, given in 1.2.1, "applicable fire exposure" shall correspond to the standards of fire integrity and insulation, specified in the appropriate bulkheads and decks fire integrity tables. For example, if for such divisions as decks or side and end bulkheads of deckhouses fire integrity equal to "B-0" is allowed, then "applicable fire exposure" shall be equal to half an hour.

If aluminum alloys are used, the requirements of 2.1.1.3 shall be met.

**2.1.1.2** Casings and crowns of machinery spaces of category A shall be of steel and insulated as required by Tables 2.3.3-1 and 2.4.2-1 as appropriate.

The floor plating of normal passageways in machinery spaces of category A shall be made of steel.

**2.1.1.3** If any part of the division is manufactured of aluminum alloys, the following requirements shall be complied with:

.1 parts of "A" or "B" class divisions, made of aluminum alloy, except the divisions, which are not loadbearing, shall be insulated so, that the temperature of the structural core of the specimen does not rise more than 200°C above the ambient temperature at any time during the applicable fire exposure at the standard fire test;

<sup>5</sup> Refer to IMO MSC/Circ.1002 with Corr.1, Corr.2, Corr.3 and IMO MSC.1/Circ.1552.

.2 special attention shall be given to insulation of aluminum alloy components of columns, stanchions and other structural members required to support lifeboat and life raft stowage, launching and embarkation areas and "A" and "B" class divisions to ensure that:

**2.1** such members required to support lifeboat and life raft stowage, launching and embarkation areas and "A" type divisions comply with the temperature rise limitation requirement, as specified in 2.1.1.3.1, at the end of an hour;

**2.2** such members required to support "B" class divisions comply with the temperature rise limitation requirement, as specified in 2.1.1.3, at the end of half an hour.

**2.1.1.4** In accommodation spaces, service spaces and control stations of all types of ships the total mass of combustible materials of each enclosed space shall be calculated based on the following formula:

$$M_{rel} = M_t/S \quad (2.1.1.4)$$

where  $M_{rel}$  - the total mass of combustible materials per unit area of the space, in kg/m<sup>2</sup>;

$M_t$  - the total mass of combustible materials of the space, in kg;

$S$  - the floor area of the space, in m<sup>2</sup>.

The following combustible materials shall be included to the calculations:

.1 construction materials as cables insulation, plastic pipes, veneers and combustible materials permitted to be used according to the present Part;

.2 outfitting, which may be installed during construction or provided by the shipowner or crew, including furniture, bedding components and electrical appliances.

Maximum values for the total mass of combustible materials per unit area  $M_{rel}$ , in kg/m<sup>2</sup>, shall not exceed the values specified in Table 2.1.1.4.2. Space categories shall correspond to the ones specified in 2.2.1.3, 2.2.1.5, 2.3.3 or 2.4.2, depending on the ship type.

**Table 2.1.1.4**

Ship type	Space category		
	Passenger ship carrying more, than 36 passengers	Passenger ship carrying not more, than 36 passengers	Cargo ships
Stairways, corridors	5	5	5
Control stations	5	5	5
Accommodation spaces	15 - minor fire risk, 35 - moderate and greater fire risk	35	35
Service spaces surrounded by "A" class divisions	45	45	45

**2.1.1.5** Insulation materials shall be non-combustible, except for use in cargo spaces, postal and baggage storerooms and refrigerated storerooms of service spaces. Vapour barriers and adhesives used in conjunction with insulation, as well as insulation of piping fittings of cooling systems and piping of cooling water of the conditioning systems may be combustible, but they shall be kept to the minimum as far as practicable, while their exposed surfaces shall be low flame-spread.

Insulating materials shall not contain asbestos<sup>6</sup>.

In the spaces where oily products may be present the insulation surface shall be oily vapours-impermeable, which may be provided by coating insulation with metallic film or glass cloth.

**2.1.1.6** Primary deck coverings, if applied within accommodation and service spaces and control stations or on cabin balconies of passenger ships constructed on or after 1 July 2008 shall be of an approved material, which has low flame spread characteristics, this being determined in accordance with the FTP Code.

Where a floor covering is required to be low flame-spread; all layers shall comply with the requirement of 1.6.3.5. If the floor covering has a multilayer construction, the tests shall be conducted for each layer or combinations of some layers of such covering. At that, the Register approval is applicable to the tested combinations of layers.

Where primary deck covering is also the exposed surface (refer to **2.1.1.8**), it shall comply with the requirements of **1.6.3.5**

Primer or similar thin film of paint on deck plating need not comply with the requirements of **1.6.3.5**.

On passenger ships constructed on or after 1 July 2008, primary deck coverings on cabin balconies shall not give rise to smoke, toxic or explosive hazards at elevated temperatures, this being determined in accordance with the FTP Code.

**2.1.1.7** Paints, varnishes and other finishings used on exposed surfaces inside service and accommodation spaces, control stations and stairways enclosures shall not generate excessive quantity of smoke and toxic vapours, this being determined in accordance with the FTP Code.

This requirement applies to the finish materials of bulkheads, decks, floor coverings, linings and ceilings, but is not applicable to cables insulation, plastic piping and furniture.

Finish materials and primary deck coverings (refer to **2.1.1.6**) with total thermal emission of not more than 0,2 MJ and maximum value of thermal emission factor not more than 1,0 kW (both values are determined in accordance with Part 5 of the FTP Code and are considered as complying with the requirements of **1.6.3.2** without tests.

On board oil tankers, chemical tankers and oil recovery ships the use of aluminium coatings containing greater than 10 % aluminium by weight in the dry film is prohibited in cargo tanks, cargo tank deck area, pump rooms, cofferdams or any other area where cargo vapour may accumulate.

On passenger ships constructed on or after 1 July 2008, paints, varnishes and other finishes used on exposed surfaces of cabin balconies, excluding natural hard wood decking systems, shall not be capable of producing excessive quantities of smoke and toxic products, this being determined in accordance with the FTP Code.

**2.1.1.8** In accordance with the FTP Code the following surface shall have low flame spread characteristics:

**.1** on passenger ships:

**.1.1** exposed surfaces in corridors and stairway enclosures, as well as bulkheads and plating, ceiling linings in accommodation and service spaces (except saunas) and control stations;

**.1.2** surfaces and grounds in concealed and inaccessible spaces in accommodation and service spaces and control stations;

**.2** on fishing vessels of 24 m in length and over and on cargo ships of 500 gross tonnage and upwards:

**.2.1** exposed surfaces in corridors and stairway enclosures and of ceilings in accommodation and service spaces (except saunas) and control stations;

**.2.2** surfaces and grounds in concealed and inaccessible spaces in accommodation and service spaces and control stations;

**.3** glues and sealants used in the "A" and "B" class divisions;

**.4** exposed surfaces of cabin balconies, except for natural hard wood decking systems;

**.5** primary deck coverings.

The above requirements apply to finish materials of bulkheads, decks, floor coverings, linings and ceilings, but is not applicable to plastic piping, electrical cables and furniture.

**2.1.1.9** On passenger ships carrying more than 36 passengers in accommodation spaces, the furniture and furnishings of which constitute restricted fire risk, upholstered furniture, bedding components, draperies and curtains and other vertically supported textile materials shall be satisfactorily tested in compliance with the FTP Code (refer to **1.6.3.6 - 16.3.8**). For other types of ships, the said requirements are recommended only.

**2.1.1.10** On passenger ships, "A", "B" and "C" class divisions in accommodation and service spaces and cabin balconies, which are faced with combustible materials, facings, mouldings, decorations and veneers shall comply with the requirements of the present paragraph and **2.1.1.6 - 2.1.1.8**. However, traditional wooden benches and wooden linings of bulkheads and ceilings are allowed in saunas and such materials may not be taken into calculation required by the paragraph.

On cargo ships, non-combustible bulkheads, ceilings and linings fitted in accommodation and service spaces may be faced with combustible materials, facings, mouldings, decorations and veneers provided such spaces are bounded by non-combustible bulkheads, ceilings and linings in accordance with the requirements of the present paragraph and **2.1.1.6 - 2.1.1.8**.

Combustible materials used on the surfaces and linings shall have calorific value not exceeding 45 MJ/m<sup>2</sup> taking into consideration their thickness. Requirements of this article are not applicable to the surfaces of furniture fixed to linings or bulkheads.

Calorific value  $Q$ , in MJ/m<sup>2</sup>, taking into consideration the thickness of covering material, is determined by the formula

$$Q = Q_g p s \quad (2.1.1.10)$$

where  $Q_g$  - the maximum specific heat of combustion determined oil in accordance with ISO 1716 "Construction Materials. Determination of the Calorific Potential", in MJ/kg;

$p$  - the density of material, in kg/m<sup>3</sup>;

$s$  - the thickness of material, in m.

Where combustible materials are used in accordance with the present paragraph, they shall comply with the following requirements:

**.1** the total volume of combustible facings, mouldings, decorations and veneers in any accommodation or service spaces shall not exceed a volume equivalent to 2,5 mm veneer of the combined area of the walls and ceiling linings. The furniture fixed to linings, bulkheads or decks may be not included into the calculation of the total volume of combustible materials;

.2 in case of ships fitted with an automatic sprinkler system complying with the provisions of the FSS Code, the above volume may include some combustible materials used for erection of "C" class divisions.

On non-self-propelled ships without regard of their gross tonnage it is permissible to fit non-combustible bulkheads, linings and ceilings with combustible covering less than 2 mm thick except corridors, stairway enclosures as well as control stations where thickness of covering shall not exceed 1,5 mm.

The furnishings specified in 2.1.1.10.1 and 2.1.1.10.2 and applied on cabin balconies may not be taken into calculation required by the paragraph.

**2.1.1.11** All waste receptacles shall be constructed of non-combustible materials with no openings in the sides and bottom.

Containers constructed of combustible materials may be used in galleys, pantries, bars, garbage handling or storage spaces and incinerator rooms provided they are intended purely for the carriage of wet waste, glass bottles or metal cans and are suitably marked.

**2.1.1.12** If the ship's structures are made of glass-reinforced plastic in accordance with Part XVI "HULL STRUCTURE AND STRENGTH OF GLASS-REINFORCED PLASTIC SHIPS AND BOATS", the fire-retardant properties and fire resistance of such structures shall be tested according to the procedure set out in the Fire Test Procedures Code.

**2.1.2.1** "A" class divisions are those divisions which are formed by bulkheads or decks complying with the following requirements:

.1 they shall be constructed of steel or other equivalent material;  
 .2 they shall have respective stiffening elements;  
 .3 they shall be so constructed as to be capable of preventing the passage of smoke and flame up to the end of the 60-min standard fire test;

.4 they shall be so insulated with approved non-combustible material that the average temperature of the unexposed side will not rise more than 140 8C above the original temperature, nor will the temperature, at any one point, including any joint, rise more than 180 8C above the original temperature.

Depending on the time during which the above-indicated temperature rise is ensured in the course of the standard fire test, the following symbols are given to divisions: "A-60" - during 60 min; "A-30" - during 30 min; "A-15" - during 15 min; "A-0" - during 0 min.

**2.1.2.2** When approving the structural fire protection the danger of heat transfer through joints and ends of insulation shall be taken into account. Insulation of steel and aluminium decks and bulkheads shall extend for at least 450 mm beyond boundaries of structures forming the given space.

If a space is divided by the "A" class deck or bulkhead with an insulation of different size, then an insulation of greater size shall extend over the deck and bulkhead for at least 450 mm from the less insulated structure.

Measures taken to prevent heat transfer through joints and ends of insulation of decks and bulkheads are shown in Figs. 2.1.2.2-1 and 2.1.2.2-2. The Register may approve some other variants of such measures, provided the efficacy of the proposed structure is verified by the results of tests conducted in accordance with the FTP Code.

Where the lower part of insulation is cut off to provide drainage, the structure shall comply with Fig. 2.1.2.2-3.

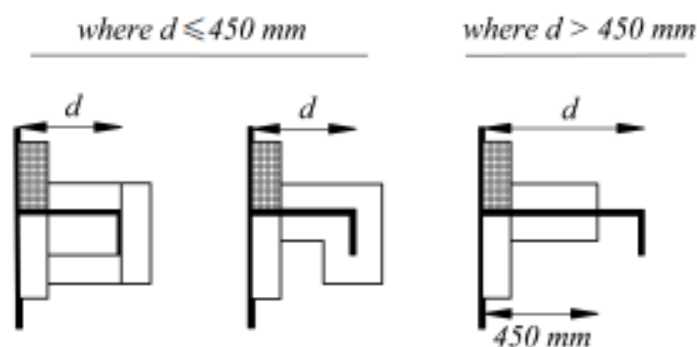

Fig. 2.1.2.2-1

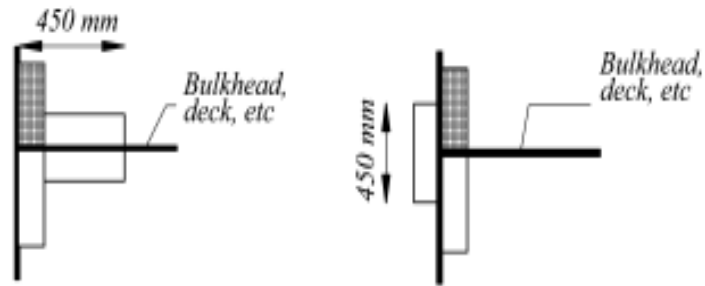

Fig. 2.1.2.2-2

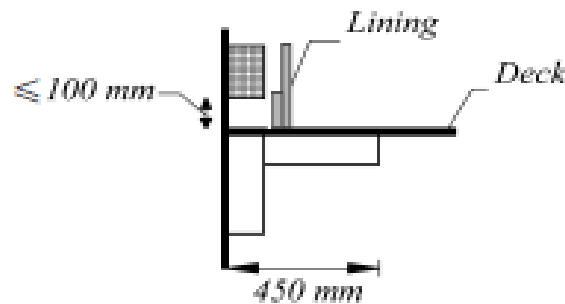

Fig. 2.1.2.2-3

Note.  $d$  - height of the stiffener at the longitudinal member.

■ -structural insulation

▒ -insulation in accordance with 2.1.2.2.

**2.1.2.3** Lightweight (honeycomb and other) structures made of steel or other equivalent material may be used as internal divisions of "A" class in the accommodation and service spaces, provided they are not load-bearing structures and successfully passed prescribed tests in accordance with the FTP Code. Such lightweight structures shall not be used as the components of the main fire protection zones and stairways enclosures in passenger ships.

**2.1.2.4** The following elements may be fitted without tests:

**.1** "A-0" class bulkheads, if made of steel and having the dimensions not less than the following:

plate thickness - 4 mm;

stiffeners 60x60x5 mm located at a distance of 600 mm from each other or having similar construction;

**.2** "A-0" class decks if made of steel and having the dimensions not less than the following:

plate thickness - 4 mm;

stiffeners 95x65x7 mm located at a distance of 600 mm from each other or having similar construction.

**2.1.2.5** "B" class divisions are those divisions which are formed by bulkheads, decks, ceilings or linings which comply with the following requirements:

**.1** they are made of approved non-combustible materials.

Use of combustible veneer is permitted (refer to 2.1.1.8 and 2.1.1.10);

**.2** divisions shall be so constructed as to remain capable of preventing the passage of flame up to the end of the 30-minute standard fire test;

**.3** divisions shall have an insulation value such that the average temperature on the unexposed side during the fire test will not rise more than 140°C above the original temperature, nor will the temperature at any one point, including any joint, rise more than 225°C above the original temperature when either side is exposed to the fire test.

According to the time during which the above-mentioned temperature rise is ensured in the course of the standard fire test, the following symbols are given to divisions: "B-30" - during 30 min; "B-15" - during 15 min.; "B-0" - during 0 min.



**2.1.2.6** Materials used in the "A" and "B" class divisions, which according to the present Part shall have particular characteristics (be non-combustible, low flame-spread or not generating excessive quantities of smoke and toxic agents), shall comply with the requirements of the FTP Code (refer to **1.6.3.1**, **1.6.3.2** and **1.6.3.5**).

**2.1.2.7** Continuous "B" class ceilings and linings with the relevant decks or bulkheads may be considered as fully or partially ensuring insulation and fire integrity of structures, as required by the respective fire integrity tables.

**2.1.2.8** "C" class divisions are the divisions made of approved non-combustible materials. They do not need meet any requirements relative to the passage of smoke and flame or the limiting of temperature rise. It is not required that gluing materials in these structures be non-combustible, however, these materials shall be low flame-spread.

**2.1.2.9** Divisions consisting of non-combustible core and combustible veneers may be accepted as "B" or "C" class divisions, provided that the non-combustible core is tested and complies with the requirements of **1.6.3.1**, and the "B" class division is tested and complies with the requirements of **2.1.2.4**, and the veneers, if applicable, are tested and comply with the requirements of **1.6.3.2** and **1.6.3.5**.

### **2.1.3 Closures of openings in fire-fighting divisions.**

**2.1.3.1** Fire integrity of doors shall be equal to fire integrity of the divisions where they are installed, which is determined in accordance with the FTP Code and applicable provisions of IMO circular MSC.1/Circ.1319 for large fire doors. Doors and doorframes in "A" class divisions shall be made of steel or other equivalent material. Doors in "B" class divisions shall be non-combustible.

**2.1.3.2** The doors designed in compliance with the requirements of **7.5.2** and **7.12**, Part III "Equipment, Arrangements and Outfit" and fitted according to **7.12** of the above mentioned Part, and, in certain cases (e.g., for providing gas tightness), if specially agreed with the Register, may be fitted in "A" class bulkheads. As doors fitted in watertight bulkheads of cargo and passenger ships and subject to fire integrity and water tightness requirements, watertight doors may serve but not need to be fire-tested notwithstanding the fire integrity of the division in which they are fitted.

However, such doors fitted above the bulkhead deck on passenger ships shall be tested to the FTP Code in accordance with the fire integrity of the division they are fitted.

If it is not practical to ensure self-closing for the said doors which shall be self-closing, means of indication on the bridge showing whether these doors are open or closed and a notice "TO BE KEPT CLOSED AT SEA" can be alternative of the self-closing.

Where a watertight door is located adjacent to a fire door, both doors shall be capable of independent operation, remotely if required by **7.12**, Part III "Equipment, Arrangements and Outfit" and from both sides of each door.

**2.1.3.3** If the "A" class divisions are penetrated, then such penetrations (cutouts) shall be tested in accordance with the FTP Code, considering the provisions of **2.2.1.4**. The requirements of **12.1.12** and **12.1.23**, Part VIII "Systems and Piping" are applied to ventilation ducts. Tests may not be conducted if the pipes penetrations are made of steel or other equivalent material with a thickness of 3 mm or greater and a length of not less than 900 mm (preferably 450 mm at each side of the division) and do not have any openings. Such penetrations shall be insulated similar to the division itself.

In case where pipe penetrations and cable transits are constructed without structural sockets and consist of removable sleeves welded or bolted to the division and/or of soft or intumescent filling material, these sleeves shall be of minimum 3 mm thickness and of minimum 60 mm length and filling material shall be adequately secured by bonded materials or mechanical means in order to prevent damage or fall out. Such penetrations shall not impair fire integrity and structural strength of the divisions.

**2.1.3.4** If "B" class divisions are penetrated for the passage of electric cables, pipes, ducts, trunks, etc., or for the fitting of the ventilation terminals, lighting fixtures and similar devices, arrangements shall be provided to ensure fire integrity of a division. Ventilation ducts shall comply with the requirements of **12.1.13**, Part VIII "Systems and Piping". Pipes other than steel or copper that penetrate "B" class divisions shall be protected by the following:

.1 fire tested penetration device, adequate to the fire integrity of the division penetrated and the type of pipes used; or

.2 steel sleeve, having a thickness of not less than 1,8 mm and a length of not less than 900 mm for pipe diameters of 150 mm or greater and not less than 600 mm for pipe diameters of less than 150 mm (preferably equally divided at each side of the division). Pipes shall be connected to the ends of the sleeve by flanges or

couplings; or the clearance between the sleeve and the pipe shall not exceed 2,5 mm; or any clearance between the pipe and the sleeve shall be made tight by means of non-combustible or other suitable material.

**2.1.3.5** Uninsulated metallic pipes penetrating "A" or "B" class divisions shall be made of materials having a melting temperature exceeding 950°C for "A-0" class divisions and 850 8C for "B-0" class divisions.

**2.1.3.6** In ships other than passenger ships carrying more than 36 passengers external boundaries, which shall be made of steel or other equivalent material, may be penetrated for the fitting of windows and side scuttles, provided there is no requirement in the present Part for such boundaries to be of "A" class.

In such boundaries, which are not required to be of "A" class, doors on agreement with the Register may be made of materials the ventilation ducts than the ones of the boundary.

**2.1.3.7** Balancing openings or ducts between two enclosed spaces are prohibited except for the openings permitted by **2.2.4.3** and **2.3.8**.

**2.1.4 Measures for prevention of spread of fire and smoke.**

**2.1.4.1** For machinery spaces provision shall be made to control the opening and closing of skylights, arrangements for closing openings in funnels, which normally ensure exhaust ventilation as well as closing of ventilation flaps.

The controls shall be located outside the serviced space where they would not be isolated in case of fire in the space.

**2.1.4.2** For the protection of openings in the boundaries of A category machinery spaces the following measures shall be taken:

.1 the number of skylights, doors, ventilation openings, openings in funnels to permit exhaust ventilation and other openings shall be reduced to a minimum required for ventilation, as well as proper and safe operation of ship;

.2 skylights shall be made of steel and shall have no glass panels;

.3 provision shall be made to control the closing of power operated doors or actuating release mechanism of doors other than watertight power operated doors. The controls shall be located outside the serviced space where they would not be isolated in case of fire in the space;

.4 windows shall not be fitted in machinery spaces boundaries. However, this does not preclude the use of glass in control stations within the machinery spaces;

.5 in passenger ships the requirements of **2.2.4.1** shall be met additionally.

Skylights of cargo pump rooms, specified in **1.5.7.1**, shall be made of steel and shall be closed from a position located outside the pump room.

**2.1.4.3** In accommodation and service spaces, as well as in control stations stairways and lift trunks shall be protected in the following way:

.1 in cargo ships stairways which penetrate only a single deck shall be protected at least at one level by at least "B-0" class divisions and self-closing doors. Lifts which penetrate only a single deck shall be surrounded by "A-0" class divisions with steel doors at both levels. Stairways and lift trunks which penetrate more than a single deck shall be surrounded by at least "A-0" class divisions and protected by self-closing doors at all levels. Stairway enclosures may be arranged so as to allow to go from one stair to a superimposed stair within such enclosure (Fig. 2.1.4.3.1-1), or to enclose the stairs only with doors at each end of the stair (Fig. 2.1.4.3.1-2), or to enclose the stairs only in combination with fully closed steel stairs and doors fitted at the end of each stair (Fig. 2.1.4.3.1-3);

.2 on ships having accommodation for 12 persons or less, where stairways penetrate more than a single deck and where there are at least two escapes direct to the open deck at every accommodation level, stairways and lift trunks may be protected by "B-0" class divisions;

.3 in passenger ships the stairways and lift trunks shall be protected in compliance with **2.2.2.4**;

.4 the construction of stairways shall comply with the requirements of **8.5.4**, Part III "Equipment, Arrangements and Outfit".

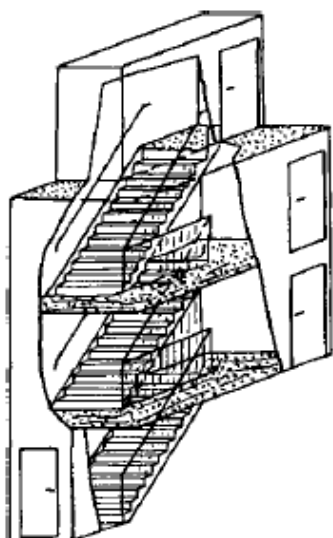

Fig. 2.1.4.3.1-1

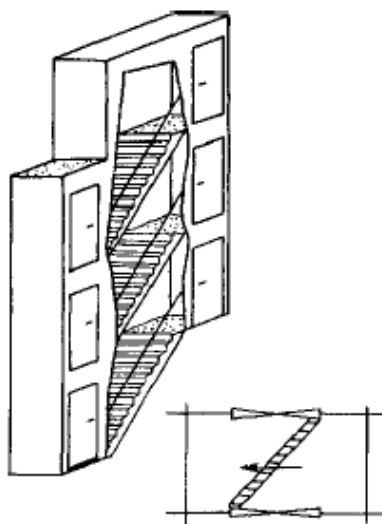

Fig. 2.1.4.3.1-2

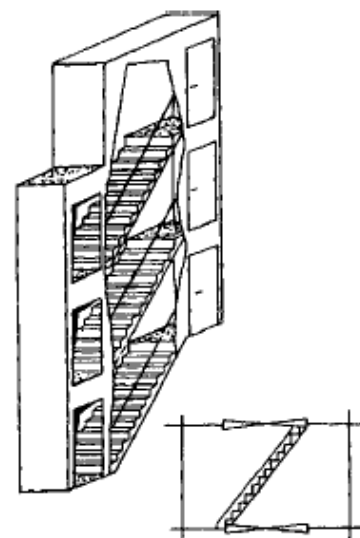

Fig. 2.1.4.3.1-3

2.1.4.4 Air spaces enclosed behind ceilings, panellings, or linings shall be divided by close-fitting draught stops spaced not more than 14 m apart.

In the vertical direction, such air spaces, including those behind linings or stairways, trunks, etc. shall be closed at each deck.

2.1.4.5 In machinery spaces from which two stairways are provided in accordance with 4.5, Part VII "Machinery Installations" one of them shall be protected by enclosure along its whole length meeting requirement 2.2.1.3 category (2) or requirements 2.2.1.5 category (4), 2.3.3 or 2.4.2, as appropriate. Self-closing fire doors of the same type of fire integrity shall be fitted in the enclosure.

Stairways shall be arranged to avoid transfer of heat to the enclosure through uninsulated fixing points.

2.1.4.6 In addition to watertight door separating the machinery space of category A from the shaft tunnel, from the side of the latter a light steel fire-screen door shall be fitted to be operated from each side.

2.1.4.7 Permanent openings in the side shell, ends and ceiling of enclosed spaces for the carriage of vehicles, enclosed ro-ro spaces, as well as special category spaces shall be so situated that a fire in these spaces does not endanger stowage areas and embarkation stations for lifeboats and liferafts, accommodation spaces, service spaces and control stations in superstructures and deckhouses above the mentioned spaces.

#### 2.1.5 Additional requirements to spaces of separate categories.

In addition to the requirements of Section 2, the following requirements to structural fire protection shall be complied with.

2.1.5.1 Saunas shall comply with the following requirements:

.1 the perimeter of the sauna shall be of "A-60" class boundaries except spaces inside of the perimeter and spaces of categories (5), (9) and (10) as specified in 2.2.1.3, or spaces of categories (5), (7) and (10) as specified in 2.2.1.5.1, 2.3.3, 2.4.2, 2.5.3 or 2.6.3, depending on the purpose of ship;

.2 saunas may include changing rooms, showers and toilets. Bathrooms with direct access to saunas may be considered as part of them. In such cases, the door between sauna and the bathroom need not comply with fire safety requirements;

.3 the traditional wooden lining on the bulkheads and ceiling are permitted in the sauna. The ceiling above the oven shall be lined with non-combustible plate with an air gap of at least 30 mm. The distance from the hot surfaces to combustible materials shall be at least 500 mm or the combustible materials shall be protected (e.g., by a non-combustible plate with an air gap of at least 30 mm);

.4 the traditional wooden benches are permitted in saunas;

.5 the sauna door shall have no locks and open outwards by pushing;

.6 electrically heated ovens shall be provided with a timer and meet the requirements of Section 15, Part XI "Electrical Equipment", while cables and wires shall meet the requirements of 16.8 of the same Part.

2.1.5.2 Galleys shall comply with the following requirements:

.1 galleys utilizing sources of power other than electricity shall not be adjacent to storerooms for flammable materials and substances or to fuel oil and lubricating oil tanks;

.2 galley decks shall be covered with ceramic tiles or similar non-combustible covering;

.3 exhaust ventilation ducts from galley ranges shall meet the requirements of **12.2.4**, **12.2.7** or **12.3.6**, Part VIII "Systems and Piping".

**2.1.5.3** Storerooms for flammable materials and substances shall comply with the following requirements:

.1 storerooms for flammable materials shall not be generally situated in common with accommodation spaces in superstructure or deckhouse. Access to the storerooms shall be provided from the open deck directly or through a corridor and/or a stairway leading only to these storerooms;

.2 all electrical equipment of the storeroom shall be explosion proof in compliance with **2.9**, Part XI "Electrical Equipment".

**2.1.5.4** Spaces for electric and gas welding operations shall comply with the following requirements:

.1 the spaces shall be separated from adjacent spaces by "A-60" class divisions;

.2 spaces shall have direct access from the open deck; the doors shall open outwards and be fitted with locks;

.3 location and arrangement of such spaces in oil tankers shall meet the requirements of **2.1.5.4.1**, **2.1.5.4.2** and as follows:

.3.1 spaces shall be positioned aft of cargo and slop tanks as well as protecting cofferdams;

.3.2 spaces shall be provided with mechanical ventilation, which shall ensure at least twenty air changes per hour;

.3.3 the possibility of welding operations shall be excluded with the access door opened and with inactive mechanical ventilation;

.3.4 the warning plates:

«**DO NOT ENTER! WELDING!**» shall be provided on the room doors;

.4 oxygen and acetylene cylinders for electric and gas welding operations shall be kept in separate storerooms, complying with the following requirements:

.4.1 acetylene cylinders storeroom shall be independent of the oxygen cylinder storeroom;

.4.2 storerooms shall be located on or above the uppermost continuous deck and shall not be adjacent to accommodation spaces, control stations, galleys, storerooms for flammable materials, as well as to fuel oil and lubricating oil tanks;

.4.3 divisions separating the storerooms from adjacent spaces shall be of "A-60" class;

.4.4 such spaces shall have direct access from the open deck, the doors shall open outwards and be fitted with locks providing their reliable closure to prevent unauthorized access;

.4.5 the warning plates:

"**DANGER OF EXPLOSION!**" and "**NO SMOKING!**" shall be provided on the storerooms doors.

**2.1.5.5** Cargo spaces specified in **1.5.4.3**, **1.5.4.4** and **1.5.9**, in which motor vehicles with fuel in their tanks are carried, shall comply with the following requirements:

.1 entrances to the cargo spaces from accommodation, machinery and special electrical spaces shall be equipped with self-closing permanently closed doors. The coamings height of these doors shall not be less than 450 mm;

.2 warning plates prohibiting smoking shall be provided near the entrances to the cargo spaces;

.3 the cargo spaces shall comply with the requirements of **12.6**, Part VIII "Systems and Piping" and **19.3**, Part XI "Electrical Equipment".

**2.1.5.6** A portion of open deck recessed into a deck structure, machinery casing, deck house, etc, used for the exclusive storage of gas bottles shall comply with the following requirements:

.1 such a recess shall have an unobstructed opening, except for small appurtenant structures, such as opening corner radii, small sills, pillars, etc. The opening may be provided with grating walls and doors;

.2 the depth of such a recess shall not be greater than 1 m;

.3 a portion of the open deck complying with the requirements of **2.1.5.6.1** and **2.1.5.6.2**, is considered as open deck in applying Tables 2.2.1.3-1, 2.2.1.3-2, 2.2.1.5-1, 2.2.1.5-2, 2.3.3-1, 2.3.3-2, 2.4.2-1, 2.4.2-2.

**2.1.5.7** Fan rooms serving engine rooms shall meet the following requirements:

.1 a fan room solely serving the engine room or multiple spaces containing an engine room may be treated as machinery space having little or no fire risk, in this case boundaries between the fan room and engine room casing shall be of "A-0" fire integrity;

.2 a fan room solely serving the engine room may be considered as part of the engine room, in this case the requirements for fire integrity of the horizontal boundary between fan room and engine room need not apply;

.3 for both of the cases described above, for any space(s) adjacent to the fan room superstructure, the fire integrity of the separating bulkhead(s) shall meet the applicable fire integrity requirements contained in the present Rules.

**2.1.5.8** Independent back-up dynamic positioning control system shall be arranged in a special space separated by "A-60" class bulkhead from the main control station in accordance with **8.9.3**, Part XV "Automation".

**2.1.5.9** Incinerators and waste stowage spaces.

**2.1.5.9.1** As regards structure, equipment and insulation, the incinerator rooms shall be considered as category "A" machinery spaces; waste stowage spaces, garbage grinding and compacting spaces - as service spaces.

Structural fire protection shall be performed in accordance with **2.2.1.3 (12)**, **2.2.1.5 (6)**, **(9)**, **2.3.3 (6)**, **(9)**, **2.4.2 (6)**, **(9)** (refer to Table 1).2.2.1.3-1, 2.2.1.3-2; 2.2.1.5-1, 2.2.1.5-2; 2.3.3-1, 2.3.3-2; 2.4.2-1, 2.4.2-2) as appropriate.

**2.1.5.9.1** Requirements for structural fire protection in compliance with 2.2.1.3, 2.2.1.5, 2.3.3, 2.4.2 may not be applied, if the spaces are arranged aft as far as practicable; at least 3 m from entrances, air inlets or openings to accommodations, service spaces and control stations, not less than 5 m measured horizontally from the nearest hazardous area or vent outlet from a hazardous area; not less than 2 m shall separate the incinerator and the waste material stowage area, unless physically separated by a structural fire barrier in accordance with **2.1.5.9.1**.

The spaces are located on weather deck shall be accessible with two means of fire extinguishment; either fire hoses or fire extinguishers in compliance with para **5**, Table 5.1.2; fire monitors, or fixed fire-extinguishing system.

**2.1.5.10 Special electrical spaces.**

**2.1.5.10.1** The minimum fire resistance of bulkheads and decks that restrict special electrical spaces (refer to **1.5.10**) or separate such adjacent spaces depends on the purpose of the vessel.

Structural fire protection shall be performed in accordance with the requirements of Tables 2.2.1.3-1, 2.2.1.3-2; 2.2.1.5-1, 2.2.1.5-2; 2.3.3-1, 2.3.3-2; 2.4.2-1, 2.4.2-2 appropriate to the ship's purpose.

**2.1.5.10.2 Special purpose passenger ships.**

.1 spaces of deck area less than 4m<sup>2</sup> - structural fire protection according to **2.2.1.3(7)** and **2.2.1.5(5)** as appropriate;

.2 1 spaces of deck area 4m<sup>2</sup> and over:

.2.1 with sectional electrical switchboards and electrical equipment, including those having oil transformers with a capacity not exceeding 10kVA or other electrical equipment that holds fire hazardous liquids – **2.2.1.3(10)**;

.2.2 with sectional electrical switchboards and electrical equipment with a capacity over 10kVA, including those having oil transformers with a capacity over 10 or other electrical equipment that holds fire hazardous liquids – **2.2.1.3(11)** and **2.2.1.5(5)** as appropriate;

.3 spaces of electrical equipment (automatic telephone exchanges, air conditioning systems, etc.) – **2.2.1.5(7)**.

*Note:* Special purpose ships carrying: up to 240 shall comply with the requirements of Tables 2.2.1.3-1 and 2.2.1.3-2; over 240 persons shall comply with the requirements of Tables 2.2.1.5-1, 2.2.1.5-2.

**2.1.5.10.3 Cargo ships, oil tankers and combined carriers with a gross tonnage of 500 and over and fishing vessels with a gross tonnage of 500 and over and / or with a length of 45 m and over.**

.1 spaces of deck area less than 4m<sup>2</sup> - structural fire protection according to **2.3.3(5)** or **2.4.2(5)** or **2.5.3(5)** appropriate to the ship's purpose;

.1 spaces of deck area 4m<sup>2</sup> and over:

.2.1 with sectional electrical switchboards and electrical equipment, including those having oil transformers with a capacity not exceeding 10kVA or other electrical equipment that holds fire hazardous liquids – **2.3.3(5)** or **2.4.2(5)** or **2.5.3(5)** appropriate to the ship's purpose;

.2.2 with sectional electrical switchboards and electrical equipment with a capacity over 10kVA, including those having oil transformers with a capacity over 10 or other electrical equipment that holds fire hazardous liquids – **2.3.3(9)** or **2.4.2(9)** or **2.5.3(9)** appropriate to the ship's purpose;

.3 spaces of electrical equipment (automatic telephone exchanges, air conditioning systems, etc.) – **2.3.3(7)** or **2.4.2(7)** or **2.5.3(7)** appropriate to the ship's purpose.

## 2.2 PASSENGER SHIPS

### 2.2.1 General.

**2.2.1.1** The requirements of this Chapter are additional to those set out in 2.1 as well as changes and additions made in accordance with Directive 2009/45 / EC as amended (latest Directive (EU) 7017/2108 of 15.11.2017) on the Rules and Standards for the Safety of Passenger Ships.

**2.2.1.2** For ships carrying more than 36 passengers, the hull, superstructure and deckhouses shall be divided into main vertical zones by "A-60" class divisions. Steps and recesses shall be kept to a minimum, but where they are necessary they shall also be "A-60" class divisions. Where a class **2.2.1.3 (5)**, **2.2.1.3 (9)** or **2.2.1.3 (10)** space is on one side of the division the class may be reduced to "A-0".

For ships carrying not more than 36 passengers, the hull, superstructure and deckhouses in way of accommodation and service spaces shall be divided into main vertical zones by "A" class divisions. These divisions shall have insulation values in accordance with Tables 2.2.1.5-1 and 2.2.1.5-2

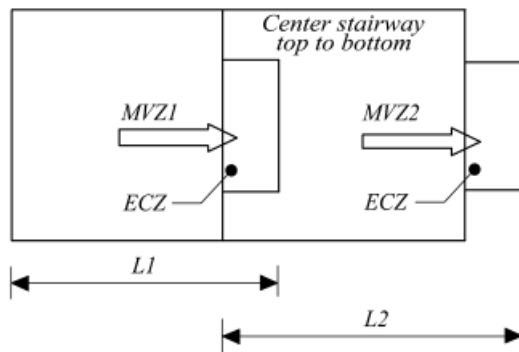

Fig. 2.2.1.2-1

ECS serves one MVZ

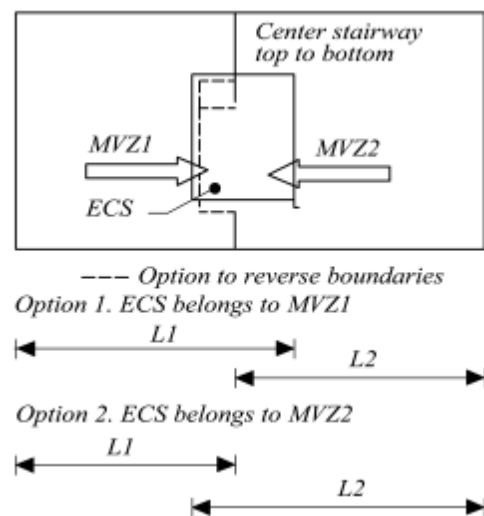

Fig. 2.2.1.2-2

ECS serves two MVZ

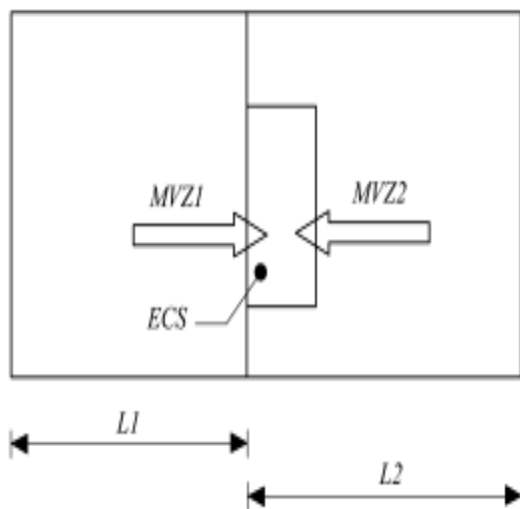

Fig. 2.2.1.2-3  
ECS serves two MVZ (ECS belongs to MVZ2)

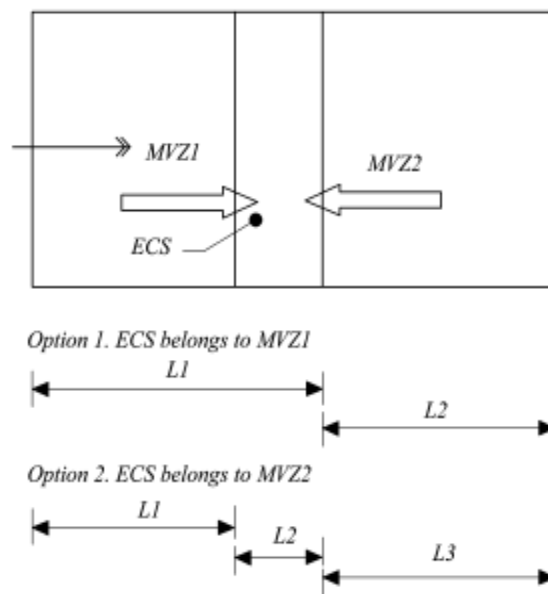

Fig. 2.2.1.2-4  
ECS serves two MVZ

Notes to Figs. 2.2.1.2-1 - 2.2.1.2-4:

*MVZ*: Main vertical zone

*ECS*: Escape stairway

→ : Direction of escape.

As far as practicable, the bulkheads forming the boundaries of the main vertical zones above the bulkhead deck shall be in line with watertight subdivision bulkheads situated immediately below the bulkhead deck. The length and width of main vertical zones may be extended to a maximum of 48 m in order to bring the ends of main vertical zones to coincide with subdivision watertight bulkheads or in order to accommodate a large public space extending for the whole length of the main vertical zone provided that the total area of the main vertical zone is not greater than 1600 m<sup>2</sup> on any deck.

If a stairway serves two main vertical zones, then maximum length of one main vertical zone shall be measured from the far side of the main vertical zone stairway enclosure. In this case, all boundaries of the stairway enclosure are to be insulated as main vertical zone bulkheads and access doors leading to the stairway are to be provided from these zones (refer to Figs. 2.2.1.2-1 to 2.2.1.2-4). However, the stairway is not to be included in calculating size of the main vertical zone if it is treated as its own main vertical zone.

Bulkheads forming the boundaries of main vertical zones shall extend from deck to deck and to the shell or other boundaries.

Where the main vertical zone is divided by horizontal "A" class divisions into horizontal zones for the purpose of providing an appropriate barrier between sprinklered and non-sprinklered zones of the ship, the divisions shall extend between adjacent main vertical zone bulkheads and to the shell or exterior boundaries of the ship and shall be insulated in accordance with the fire insulation classes given in Table 2.2.1.5-2.

On ships designed for special purposes, such as automobile or railroad car ferries, where the provision of main vertical zone bulkheads would defeat the purpose for which the ship is intended, equivalent means for controlling and limiting a fire, such as water screens complying with the requirements of 3.5, shall be provided.

Service spaces and storerooms if they are not protected in compliance with the applicable requirements shall not be located on decks of ships specified in 1.5.4.3.

#### 2.2.1.2.1 Protection of atriums:

.1 atriums shall be within enclosures formed of "A" class divisions having a fire rating determined in accordance with Tables 2.2.1.3-2 and 2.2.1.5-1, as applicable;

.2 decks separating spaces within atriums shall have a fire rating determined in accordance with Tables 2.2.1.3-2 and 2.2.1.5-1, as applicable.

**2.2.1.3** The minimum fire integrity of all bulkheads and decks separating adjacent spaces in ships carrying 36 passengers and more shall be as prescribed in Tables 2.2.1.3-1 and 2.2.1.3-2.

For the purpose of determining the class of structures between adjacent spaces, such spaces are classified according to their fire risk as follows.

(1) *Control stations* - spaces accommodating emergency sources of electrical power and lighting; wheelhouse and navigation room;

spaces accommodating ship radio equipment; fire stations; main machinery control room if it is located outside the space accommodating such machinery;

spaces accommodating centralized fire alarm system;

spaces accommodating central control stations and emergency loud speaking system equipment.

(2) *Stairways*: interior stairways, lifts, fully enclosed trunks for evacuation and escalators for passengers and crew (except those, which are fully located in machinery spaces) and their enclosures.

A stairway which is enclosed at only one level shall be regarded as part of the space from which it is not separated by a fire door.

(3) *Corridors*: corridors and lobbies for passengers and crew.

(4) Evacuation stations and external escape routes;

survival craft stowage area;

open deck spaces and enclosed promenades forming lifeboat and liferaft embarkation and launching stations;

muster stations, internal and external;

external stairs and open decks used for escape routes;

the ship's side to the waterline in the lightest seagoing condition, superstructure and deckhouse sides situated below and adjacent to the life rafts and evacuation slide's embarkation areas.

(5) *Open deck spaces*: open deck spaces and enclosed promenades clear of lifeboat and liferaft embarkation and launching stations. To be considered in this category, enclosed promenades shall have no fire risk. This means that furnishings shall be restricted to deck furniture. In addition, such places shall be naturally ventilated by permanent openings; air spaces (spaces outside superstructures and deckhouses).

(6) *Accommodation spaces of minor fire risk*: cabins, offices, dispensaries and public spaces containing furniture and furnishings of restricted fire risk and having a deck area of less than 50 m<sup>2</sup> (refer to **1.2**).

(7) *Accommodation spaces of moderate fire risk*: accommodation spaces as in category (6) containing furniture and furnishings other than of restricted fire risk;

public spaces containing furniture and furnishings of restricted fire risk and having a deck area of 50 m<sup>2</sup> and greater;

isolated lockers and small storerooms in accommodation spaces having areas less than 4 m<sup>2</sup> (in which flammable liquids are not stowed);

cleaning gear lockers, laboratories (in which flammable liquids are not stowed);

drying rooms (having

a deck area of 4 m<sup>2</sup> or less); diet kitchens (containing no open flame);

specie rooms;

motion picture projection rooms and film rooms;

drug-stores;

operating rooms;

spaces accommodating electrical distribution boards with an area less, than 4 m<sup>2</sup>.

(8) *Accommodation spaces of greater fire risk*: public spaces containing furniture and furnishings of other than restricted fire risk and having a deck area of 50 m<sup>2</sup> and greater, sale shops;

barber shops, beauty parlours and saunas.

**Table 2.2.1.3-1 Bulkheads not bounding either main vertical zones or horizontal zones**



Spaces	(1)	(2)	(3)	(4)	(5)	(6)	(7)	(8)	(9)	(10)	(11)	(12)	(13)	(14)
Control stations	(1)	B-0 <sup>1</sup>	A-0	A-0	A-0	A-0	A-60	A-60	A-60	A-0	A-0	A-60	A-60	A-60
Stairways	(2)		A-0 <sup>1</sup>	A-0	A-0	A-0	A-0	A-15	A-15	A-0 <sup>2</sup>	A-0	A-15	A-30	A-15
Corridors	(3)			B-15	A-60	A-0	B-15	B-15	B-15	B-15	A-0	A-15	A-30	A-0
Evacuation stations and external escape routes	(4)				A-0	A-60 <sup>3</sup>	A-60 <sup>3</sup>	A-60 <sup>3</sup>	A-0	A-0	A-60 <sup>3</sup>	A-60 <sup>3</sup>	A-60 <sup>3</sup>	A-60 <sup>3</sup>
Open deck spaces	(5)				—	A-0 <sup>4</sup>	A-0 <sup>4</sup>	A-0 <sup>4</sup>	A-0 <sup>4</sup>	A-0	A-0	A-0	A-0	A-0
Accommodation spaces of minor fire risk	(6)					B-0	B-0	B-0	C	A-0	A-0	A-30	A-0	A-30
Accommodation spaces of moderate fire risk	(7)						B-0	B-0	C	A-0	A-15	A-60	A-15	A-60
Accommodation spaces of greater fire risk	(8)							B-0	C	A-0	A-30	A-60	A-15	A-60
Sanitary and similar spaces	(9)								C	A-0	A-0	A-0	A-0	A-0
Tanks, voids and auxiliary machinery spaces having minor or no fire risk	(10)									A-0 <sup>1</sup>	A-0	A-0	A-0	A-0
Auxiliary machinery spaces, cargo spaces, special category spaces, <sup>5</sup> cargo and other oil tanks and other similar spaces of moderate fire risk	(11)										A-0 <sup>1</sup>	A-0	A-0	A-15
Machinery spaces and main galleys	(12)											A-0 <sup>1</sup>	A-0	A-60
Storerooms, workshops, pantries, etc.	(13)												A-0 <sup>1</sup>	A-0
Other spaces in which flammable liquids are stored	(14)													A-30

<sup>1</sup>If adjacent spaces marked with footnote 1 have the same fire integrity, it is not necessary to divide such spaces with a bulkhead or deck. For instance for spaces of category (12) it is not necessary to divide a galley and buffets which are part thereof with bulkheads provided the bulkheads and buffet decks have the same fire resistance equal to that of structures bordering the galley. However, it is necessary to erect a bulkhead between the galley and machinery space although both spaces have the same category (12).

<sup>2</sup>Where public toilets are installed completely within the stairway enclosure, the public toilet bulkhead within the stairway enclosure can be of "B" class fire integrity.

<sup>3</sup>The ship's side, to the waterline in the lightest seagoing condition, superstructure and deckhouse sides situated below and adjacent to the liferafts and evacuation slides may be reduced to "A-30" class.

<sup>4</sup>Where spaces of categories (6), (7), (8) and (9) are located completely within the outer perimeter of the muster station, the bulkheads of these spaces are allowed to be of "B-0" class fire integrity. Control positions for audio, video and light installations may be considered as part of the muster station.

<sup>5</sup>Where fuel oil tanks are located under a special category space, the fire integrity of the separating deck may be reduced to "A-0" class.

**Notes:** 1. The need to apply the requirements of Table 2.2.3-1 for the spaces of category (5) in respect of the bounded superstructures and deckhouses, as well as requirements of Table 2.2.1.3-2 for the spaces of category (5) in respect of the spaces bounded by the upper deck shall be determined by the ship designer and agreed with the Register.

2. Where the contents and use of a space are such that there is a doubt as to its classification, it shall be treated as a space within the relevant category having the most stringent boundary requirements.

3. Notwithstanding the provisions of 2.2.2 there are no special requirements for material or fire integrity of boundaries where only a dash appears in the tables.

4. Small enclosed spaces inside the room are treated as separate spaces if square of doorways to adjacent spaces is less than 30 % of openings (doorways). Fire integrity of bulkheads and decks surrounding such spaces shall comply with the requirements set forth in tables of the paragraph of the Rules.

(9) Sanitary and similar spaces:

communal sanitary facilities, showers, baths, water closets, etc.;

small laundry rooms;

indoor swimming pool area;

isolated serving pantries containing no cooking appliances in accommodation spaces.

Individual sanitary spaces shall be considered a portion of the spaces in which they are located.

(10) Tanks, voids and auxiliary machinery spaces having little or no fire risk:

water tanks forming part of the ship's structure;

voids and cofferdams;

auxiliary machinery spaces which do not contain machinery having a pressure lubrication system and

where storage of combustibles is prohibited, such as: ventilation and air-conditioning rooms;

windlass room;

steering gear room;

spaces accommodating stabilizer equipment;

electrical propulsion motor room;

rooms containing section switchboards and purely electrical equipment, except oil transformers (with

capacity over 10 kVA); shaft alleys and pipe tunnels;

spaces for pumps and refrigeration machinery (not handling or using flammable liquids);

closed trunks serving the spaces listed above;  
 other closed trunks such as pipe and cable trunks.

(11) *Auxiliary machinery spaces, cargo spaces, cargo and other oil tanks and other similar spaces of moderate fire risk:*

cargo oil tanks;  
 cargo holds, trunkways and hatchways;  
 refrigerated chambers;  
 fuel oil tanks (where installed in a separate space with no machinery);  
 shaft alleys and pipe tunnels allowing storage of combustibles;  
 auxiliary machinery spaces as in category (10) which contain machinery having a pressure lubrication system or where storage of combustibles is permitted;  
 fuel oil filling stations;  
 spaces containing turbine and reciprocating steam engine driven auxiliary generators and small internal combustion engines up to 110 kW driving generators, sprinkler, drencher or fire pumps, bilge pumps, etc.;  
 closed trunks serving the spaces listed above;  
 spaces accommodating oil transformers (with capacity over 10 kVA).

(12) *Machinery spaces and main galleys:*

engine and boiler rooms (other than electric propulsion motor rooms);  
 auxiliary machinery spaces other than those in categories (10) and (11) which contain internal combustion machinery or other oil-burning, heating or pumping units;  
 main galleys and annexes;  
 trunks and casings to the spaces listed above;  
 incinerator and combined incinerator/waste stowage spaces, and the flue uptakes from such spaces (refer to 2.1.5.9).

(13) *Storerooms, workshops, pantries, etc.:*

main pantries, not annexed to galleys;  
 main laundry;  
 large drying rooms (having a deck area of more than 4 m<sup>2</sup>);  
 miscellaneous stores;  
 mail and baggage rooms;  
 garbage rooms and garbage chutes connected thereto;  
 workshops (not part of machinery spaces, galleys, etc.);  
 lockers and storerooms having areas of more than 4 m<sup>2</sup> and not having provisions for the storage of flammable liquids.

(14) Other spaces in which flammable liquids are stowed:

paint rooms;  
 storerooms containing flammable liquids (including dyes, medicines, etc.);  
 laboratories (in which flammable liquids are stowed).

**Table 2.2.1.3-1 Table Decks not forming steps in main vertical zones nor bounding horizontal zones**

Spaces below		Spaces above													
		(1)	(2)	(3)	(4)	(5)	(6)	(7)	(8)	(9)	(10)	(11)	(12)	(13)	(14)
Control stations	(1)	A-30	A-30	A-15	A-0	A-0	A-0	A-15	A-30	A-0	A-0	A-0	A-60	A-0	A-60
Stairways	(2)	A-0	A-0	A-0	A-0	A-0	A-0	A-0	A-0	A-0	A-0	A-0	A-30	A-0	A-30
Corridors	(3)	A-15	A-0	A-0 <sup>1</sup>	A-60	A-0	A-0	A-15	A-15	A-0	A-0	A-0	A-30	A-0	A-30
Evacuation stations and external escape routes	(4)	A-0	A-0	A-0	A-0	—	A-0	A-0	A-0	A-0	A-0	A-0	A-0	A-0	A-0
Open deck spaces	(5)	A-0	A-0	A-0	A-0	—	A-0	A-0	A-0	A-0	A-0	A-0	A-0	A-0	A-0
Accommodation spaces of minor fire risk	(6)	A-60	A-15	A-0	A-60	A-0	A-0	A-0	A-0	A-0	A-0	A-0	A-0	A-0	A-0
Accommodation spaces of moderate fire risk	(7)	A-60	A-15	A-15	A-60	A-0	A-0	A-15	A-15	A-0	A-0	A-0	A-0	A-0	A-0
Accommodation spaces of greater fire risk	(8)	A-60	A-15	A-15	A-60	A-0	A-15	A-15	A-30	A-0	A-0	A-0	A-0	A-0	A-0
Sanitary and similar spaces	(9)	A-0	A-0	A-0	A-0	A-0	A-0	A-0	A-0	A-0	A-0	A-0	A-0	A-0	A-0
Tanks, voids and auxiliary machinery spaces having minor or no fire risk	(10)	A-0	A-0	A-0	A-0	A-0	A-0	A-0	A-0	A-0	A-0 <sup>1</sup>	A-0	A-0	A-0	A-0
Auxiliary machinery spaces, cargo spaces, special category spaces, cargo and other oil tanks and other similar spaces of moderate fire risk	(11)	A-60	A-60	A-60	A-60	A-0	A-0	A-15	A-30	A-0	A-0	A-0 <sup>1</sup>	A-0	A-0	A-30
Machinery spaces and main galleys	(12)	A-60	A-60	A-60	A-60	A-0	A-60	A-60	A-60	A-0	A-0	A-30	A-30 <sup>1</sup>	A-0	A-60
Storerooms, workshops, pantries, etc.	(13)	A-60	A-30	A-15	A-60	A-0	A-15	A-30	A-30	A-0	A-0	A-0	A-0	A-0	A-0
Other spaces in which flammable liquids are stored	(14)	A-60	A-60	A-60	A-60	A-0	A-30	A-60	A-60	A-0	A-0	A-0	A-0	A-0	A-0

<sup>1</sup>Refer to Footnote 1 to Table 2.2.1.3-1.  
 Note. Refer to notes to Table 2.2.1.3-1.

**2.2.1.4** On ships carrying not more than 36 passengers, where a space is protected by an automatic sprinkler system or fitted with a continuous "B" class ceiling, openings in decks not forming steps in main vertical zones nor bounding horizontal zones shall be closed reasonably tight and such decks shall meet the "A" class requirements.

**2.2.1.5** The minimum fire integrity of all bulkheads and decks separating adjacent spaces in ships carrying not more than 36 passengers shall be as prescribed in Tables 2.2.1.5-1 and 2.2.1.5-2 with regard to the following:

**.1** for determining the appropriate fire integrity standards to be applied to divisions between adjacent spaces, such spaces are classified according to their fire risk as shown in categories (1) - (11) below:

- (1) control stations: spaces accommodating emergency sources of electrical power and lighting; wheelhouse and navigation room; spaces accommodating ship radio equipment; fire stations;

main machinery control room if it is located outside machinery spaces; spaces accommodating centralized fire alarm system;

- (2) corridors and lobbies;

- (3) accommodation spaces as defined in 1.5.2, except corridors;

- (4) stairways:

interior stairways, lifts, totally enclosed emergency escape exits trunks and escalators (other than those wholly contained within machinery spaces) and enclosures thereto.

In this connexion, a stairway which is enclosed only at one level shall be regarded as part of the space from which it is not separated by a fire door;

**Table 2.2.1.5-1 Fire integrity of bulkheads separating adjacent spaces**

Spaces	2	3	4	5	6	7	8	9	10	11	12	13
Control stations	1)	A-0 <sup>1</sup>	A-0	A-60	A-0	A-15	A-60	A-15	A-60	A-60	*	A-60
Corridors and lobbies	2)		C <sup>2</sup>	B-0 <sup>2</sup>	A-0 <sup>3</sup> B-0 <sup>2</sup>	B-0 <sup>2</sup>	A-60	A-0 <sup>8</sup>	A-0 <sup>9</sup>	A-15 A-0 <sup>4</sup>	*	A-30 <sup>6</sup>
Accommodation spaces	3)			C <sup>2</sup>	A-0 <sup>3</sup> B-0 <sup>2</sup>	B-0 <sup>2</sup>	A-60	A-0	A-0	A-15 A-0 <sup>4</sup>	*	A-30 A-0 <sup>4</sup>
Stairways	4)				A-0 <sup>3</sup> B-0 <sup>2</sup>	B-0 <sup>2</sup>	A-60	A-0	A-0	A-15 A-0 <sup>4</sup>	*	A-30 <sup>6</sup>
Service spaces (low risk)	5)					C <sup>2</sup>	A-60	A-0	A-0	A-0	*	A-0
Machinery spaces of category A	6)						*	A-0	A-0	A-60	*	A-60
Other machinery spaces	7)							A-0 <sup>5</sup>	A-0	A-0	*	A-0
Cargo spaces	8)								*	A-0	*	A-0
Service spaces (high risk)	9)									A-0 <sup>5</sup>	*	A-30
Open decks	10)										*	A-0
Special category spaces	11)										*	A-30 <sup>6</sup>

Table 2.2.1.5-2 Fire integrity of decks separating adjacent spaces

Spaces	2	3	4	5	6	7	8	9	10	11	12	13
Control stations	1)	A-0	A-0	A-0	A-0	A-0	A-60	A-0	A-0	A-0	*	A-60 <sup>6</sup>
Corridors and lobbies	2)	A-0	*	*	A-0	*	A-60	A-0 <sup>8</sup>	A-0 <sup>9</sup>	A-0	*	A-30 <sup>6</sup>
Accommodation spaces	3)	A-60	A-0	*	A-0	*	A-60	A-0	A-0	A-0	*	A-30 A-0 <sup>4</sup>
Stairways	4)	A-0	A-0	A-0	*	A-0	A-60	A-0	A-0	A-0	*	A-30 <sup>6</sup>
Service spaces (low risk)	5)	A-15	A-0	A-0	A-0	*	A-60	A-0	A-0	A-0	*	A-0
Machinery spaces of category A	6)	A-60	A-60	A-60	A-60	A-60	*	A-60 <sup>7</sup>	A-30	A-60	*	A-60
Other machinery spaces	7)	A-15	A-0	A-0	A-0	A-0	A-0	*	A-0	A-0	*	A-0
Cargo spaces	8)	A-60	A-0	A-0	A-0	A-0	A-0	A-0	*	A-0	A-0	A-0
Service spaces (high risk)	9)	A-60	A-30 A-0 <sup>4</sup>	A-30 A-0 <sup>4</sup>	A-30 A-0 <sup>4</sup>	A-30 <sup>6</sup>	A-60	A-0	A-0	A-0	*	A-30
Open decks	10)	*	*	*	*	*	*	*	*	*	*	*
Special category spaces	11)	A-60	A-30 <sup>6</sup>	A-30 A-0 <sup>4</sup>	A-30 <sup>6</sup>	A-30 <sup>6</sup>	A-60 <sup>6</sup>	A-0	A-0	A-30	A-0	A-30 <sup>6</sup>

Footnotes to Tables 2.2.1.5-1 and 2.2.1.5-2:

<sup>1</sup> Bulkheads separating the wheelhouse and chartroom from each other may be "B-0" class. No fire rating is required for those partitions separating the navigation bridge and the safety centre when the latter is within the navigation bridge..

<sup>2</sup> "B-0" or "C" class bulkheads, where appearing in the table as main fire-fighting bulkheads required by 2.2.1.2 shall be read as "A-0" class.

<sup>3</sup> For clarification of the applicable fire integrity standard, refer to 2.2.2.1, 2.2.2.2 and 2.2.2.4.

<sup>4</sup> Where each of the adjacent spaces is protected by an automatic sprinkler system, the lower of the two values given in the tables may be used.

<sup>5</sup> Where the spaces are used for the same purpose, no divisions may be fitted between them..

<sup>6</sup> Ships constructed before 1 July 2014 shall meet at least the previous requirements applicable during the ship construction..

<sup>7</sup> Where other machinery spaces of category (7) are the spaces of low fire risk, i.e. they do not contain machinery operating in fuel oil or having a pressure lubrication systems, "A-0" class divisions are permitted (refer to Table 2.2.1.5-2).

<sup>8</sup> On ships built on or after January 1, 2018, class A-15 divisions shall be installed.

<sup>9</sup> On ships built on or after January 1, 2018, class A-60 divisions shall be installed.

Notes to Tables 2.2.1.5-1 and 2.2.1.5-2:

1 Where an asterisk appears in the tables the division shall be of steel or equivalent material, but is not required to be of "A" class.

However, if in the deck except for the decks in a space of category (10), there are penetrations for electric cables, piping and ventilation ducts, such penetrations shall be flame and smoke tight.

Divisions between control stations (emergency generators) and open decks may have air intake openings without closing appliances, except cases when fixed gas fire-fighting system is installed.

Where the requirements of 2.2.1.2 are applicable, an asterisk means "A-0" class, except categories (8) and (10).

2. If, due to the content and purpose of the space, doubts arise regarding the determination of its category, then it shall be considered as a space of the category to which higher requirements are set with respect to the fire integrity of divisions

3. Small enclosed spaces indoors, having the area of openings in bounding structures, connected to the space, less than 30%, are considered as separate spaces.

Fire integrity of divisions and decks bounding such small spaces shall comply with the Tables of this paragraph of the Rules.

## (5) service spaces (low risk):

lockers and storerooms not having provisions for the storage of flammable liquids and having areas less than 4 m<sup>2</sup>, drying rooms and laundries, spaces accommodating electrical distribution boards with an area less than 4 m<sup>2</sup>;

## (6) machinery spaces of category A:

spaces as defined in 1.2, Part VII "Machinery Installations"; incinerator and combined incinerator/ waste stowage spaces, and the flue uptakes from such spaces (refer to 2.1.5.9).

(7) *other machinery spaces*:

machinery spaces excluding spaces referred to in (6) and spaces accommodating electrical equipment (automatic telephone stations, spaces for air conditioning ducts);

(8) *cargo spaces*: all spaces, which are not special category spaces used for the carriage of cargo (including cargo tanks for oily products), as well as ventilation and hatch trunks servicing such spaces;

(9) *service spaces (high risk)*: galleys, pantries containing appliances for hot food preparation, paint rooms, lockers and storerooms with an area of 4 m<sup>2</sup> and over, spaces for storage of flammable liquids, saunas, workshops and similar spaces, which are not part of machinery spaces; waste stowage spaces and garbage chutes connected thereto.

(10) *open decks*:

open deck spaces and enclosed promenades having no fire risk. To be considered in this category, enclosed promenades shall have no fire risk. This means that furnishings shall be restricted to deck furniture. In addition, such spaces shall be naturally ventilated by means of permanent openings;

air spaces (spaces outside superstructures and deckhouses).

(11) special category spaces as defined in 1.5.9 and ro-ro spaces in compliance with 1.5.4.3;

.2 the doors from the cabins to individual sanitary spaces may be of combustible materials.

### **2.2.2 Accommodation and service spaces within a main vertical zone.**

**2.2.2.1** For ships carrying more than 36 passengers all bulkheads which are not required to be "A" class divisions shall be "B" class or "C" class divisions as prescribed in Table 2.2.1.3-1.

For ships carrying not more than 36 passengers all bulkheads within accommodation and service spaces which are not required to be "A" class divisions shall be "B" class or "C" class divisions as prescribed in Table 2.2.1.5-1.

All such divisions may be faced with combustible materials in accordance with the provisions of 2.1.1.10.

**2.2.2.2** For ships carrying not more than 36 passengers all corridor bulkheads where not required to be "A" class divisions shall be "B" class divisions which shall extend from deck to deck except:

.1 when continuous "B" class ceilings or linings are fitted on both sides of the bulkhead, the portion of the bulkhead behind the continuous ceiling or lining shall be of material which, in thickness and composition, is acceptable in the construction of "B" class divisions but which shall be required to meet "B" class integrity standards only in so far as is reasonable and practicable in the opinion of the Register;

.2 on ships equipped with an automatic sprinkler system complying with the provisions of the FSS Code, corridor bulkheads may end by the corridor ceilings provided that such bulkheads and ceilings are of "B" class in accordance with 2.2.1.5. All doors and door frames in such bulkheads shall be made of non-combustible materials and they shall have the same fire integrity as the bulkhead in which they are fitted.

**2.2.2.3** Bulkheads required to be "B" class divisions, except corridor bulkheads required by 2.2.2.2, shall extend from deck to deck and to the shell or other boundaries unless the continuous "B" class ceilings or linings, having at least the same fire integrity as the adjacent bulkhead, are fitted on both sides of it, in which case the bulkhead may terminate at the continuous ceiling or lining.

If an air gap between the cabins results in an opening in the continuous "B-15" class ceiling, the bulkheads on both sides of the air gap shall be of "B-15" class.

**2.2.2.4** Stairways in accommodation and service spaces shall be protected as follows:

Stairways and lifts shall be protected in the following way:

.1 stairways shall be enclosed by "A" class divisions with positive closing appliances of all openings, except that a stairway connecting only two decks need not be enclosed, provided the integrity of the deck is ensured by proper bulkheads or self-closing doors. When a stairway is enclosed in 'tween deck, then this enclosure shall be protected in compliance with Tables 2.2.1.3-2 or 2.2.1.5-2;

.2 stairways in public spaces may not have enclosures, provided they are located wholly within the public space;

.3 lift trunks shall be so fitted as to prevent the penetration of smoke and flame from one 'tween-deck compartment to another and shall be provided with closing appliances to prevent draught and smoke penetration. Lifts machinery located within stairways enclosure shall be arranged in a separate space, surrounded by steel boundaries, except that small passages for lift cables are permitted. Lifts, which open into spaces other, than corridors, public spaces, special category spaces, stairways and external spaces shall not open (stop) into stairways serving as the means of escape;

**.4** stairway enclosures shall have direct communications with the corridors and be of sufficient area to comply with **8.5.4.2**, Part III "Equipment, Arrangements and Outfit". Within the perimeter of such stairway, enclosures, only public toilets, lockers of non-combustible material providing storage for safety equipment and open information counters are permitted. Only corridors, public toilets, special category spaces, other escape stairways required by Part III "Equipment, Arrangements and Outfit" and external areas are permitted to have direct access to these stairway enclosures. Public spaces may also have direct access to stairway enclosures except for the backstage of a theatre;

**.5** one of the means of escape from a watertight compartment or a main fire vertical zone as required in **8.5.2.1**, Part III "Equipment, Arrangements and Outfit" shall consist of enclosed stairways which provide a continuous shelter according to the requirements of **2.2.1.3** or **2.2.1.5**;

**.6** protection of escape routes from the stairways enclosures to the life boats and life rafts embarkation stations shall be provided either directly, or by protected interior passageways, having fire integrity and insulation values for the stairways enclosures as specified by Tables 2.2.1.3-1, 2.2.1.3-2, 2.2.1.5-1, 2.2.1.5-2, as applicable;

**.7** on passenger ships constructed on or after 1 July 2008, non-load bearing partial bulkheads which separate adjacent cabin balconies shall be capable of being opened by the crew from each side for the purpose of fighting fires.

**.8** on ships with signs **B-R3-S**, **B-R3-RS**, **C-R3-S**, **C-R3-RS** and **D-R3-S**, **D-R3-RS**, spaces other than those specified in this paragraph may be located, within such stairway enclosures, which must be: empty, permanently closed and disconnected from the power supply; separated from stairway enclosures by means of class A divisions according to the requirements of Table 2.2.1.5-1. Such spaces can have direct access to stairway enclosures by means of class A doors according to the requirements of Table 2.2.1.5-1, these spaces shall also be fitted with a sprinkler fire-fighting system.

On such ships, category (10) spaces, as defined in 2.2.1.3, and auxiliary spaces (offices) located behind open information offices may have access directly to stairway enclosures, provided that they are protected by smoke alarms, and these auxiliary spaces contain only furniture with a limited fire hazard.

**2.2.2.5** In all spaces, except for refrigerated provision storerooms, cargo spaces, mail baggage cabins and saunas, the ceilings, bulkheads, linings, draught stops and grounds shall be made of non-combustible materials.

**2.2.2.5.1** Partial bulkheads and decks on passenger ships:

**.1** partial bulkheads or decks used to subdivide a space for utility or artistic treatment shall be of non-combustible materials;

**.2** linings, ceilings and partial bulkheads or decks used to screen or to separate adjacent cabin balconies shall be of non-combustible materials.

**2.2.2.6** In the case of ships fitted with an automatic sprinkler system, combustible materials used for erection of "C" class divisions may be added to the total volume of combustible materials mentioned in **2.1.1.10**.

**2.2.2.7** The construction of ceiling and bulkheading shall be such that it will be possible, without impairing the efficiency of the fire protection, for the fire patrols to detect any smoke originating in concealed and inaccessible places, except where there is no risk of fire originating in such places.

**2.2.2.8** The furniture in stairway enclosures shall consist of seats only. It shall be fixed to six seats on each deck in each stairway enclosure, be of restricted fire risk determined in accordance with the FTP Code and shall not create obstacles for passengers at the routes of escape.

The Register may permit additional seating in the main reception area within the stairway enclosure if it is fixed, non-combustible and do not create obstacles for passengers at the routes of escape.

The furniture shall not be permitted in passenger and crew corridors forming escape routes in cabin areas.

In addition to the above lockers of non-combustible material, providing storage for fire-fighting equipment and life-saving appliances required by the present Rules may be permitted.

Drinking water automation devices and ice cube machines may be permitted in corridors provided they are properly fixed and do not restrict the width of the escape routes. This applies as well to decorative flower or plant arrangements, statues or other objects of art such as painting and tapestries in corridors and stairways enclosures.

**2.2.2.9** Linings, ceilings and partial bulkheads used to screen or to separate adjacent cabin balconies shall be of non-combustible materials. Cabin balconies on passenger ships constructed before 1 July 2008 shall comply with the requirements of this paragraph by the first survey after 1 July 2008.

**2.2.2.10** Furniture and furnishings on cabin balconies shall comply with the requirements for rooms containing furniture and furnishings of restricted fire risk (refer to definitions in **1.2**) unless such balconies are protected by a fixed pressure water-spraying and fixed fire detection and fire alarm systems complying with the requirements of **3.4.1** and **4.2.1.1.5**.

**2.2.3 Motor vehicles spaces, ro-ro spaces, special category spaces.**

**2.2.3.1** When the special category spaces cannot be protected by main vertical fire zones, their protection shall be ensured by subdivision into horizontal zones. These zones may cover more than one deck, but their overall height calculated as a sum of distances between adjacent decks without regard of framing height shall not exceed 10 m.

Fire doors and passages (cutouts) in decks and bulkheads of "A" class, forming boundaries, which separate horizontal areas from each other as well as the remain part of the ship shall meet the requirements applicable to fire doors and penetrations (cutouts) in horizontal areas (refer to **2.2.4**).

**2.2.3.2** In ships carrying more than 36 passengers the boundary bulkheads and decks of special category spaces shall be "A-60" class. However, where category **2.2.1.3 (5)**, **2.2.1.3 (9)** or **2.2.1.3 (10)** space is on one side of the division the class may be reduced to "A-0". If fuel oil tanks are located under special category spaces, the fire integrity of decks between such spaces may be of "A-0" class.

In ships carrying not more than 36 passengers the boundary bulkheads of special category spaces shall be as required for category (11) spaces in 2.2.1.5-1 and the horizontal boundaries as required for category (11) spaces in Table 2.2.1.5-2.

In passenger ships carrying not more than 36 passengers, the bulkheads and decks forming boundaries of enclosed and open ro-ro spaces shall have fire integrity required for spaces of category (8) according to 2.2.1.5-1, while the horizontal boundaries shall have fire integrity required for spaces of category (8) according to 2.2.1.5-2.

**2.2.3.3** Indicators shall be provided on the navigating bridge which shall indicate when any fire door of special category spaces is closed.

**2.2.3.4** Special category spaces shall have means of escape leading to the lifeboat and liferaft embarkation places complying with the requirements of **8.5.1**, **8.5.2.3**, Part III "Equipment, Arrangements and Outfit" as well as the requirements of **2.1.4.7** and **2.2.2.4.1** of this Part.

One of escape routes from machinery spaces where the crew is normally engaged shall not have a direct access to the special category spaces.

**2.2.3.5** Special category spaces shall be fitted with an approved water spraying system that complies with the applicable provisions of **3.4**.

**2.2.3.6 Interim Guidelines for minimizing the incidence and consequences of fires in ro-ro spaces and special category spaces of ro-ro passenger ships<sup>7</sup>.**

**2.2.3.6.1** Strengthening of the requirement for elimination of sources of ignition:

**.1** a fire-fighting plan that, in particular, identifies any risks specific to alternatively powered vehicles, including battery powered vehicles, and outlines the most appropriate fire-fighting techniques for such vehicles shall be developed. Good access to any specialized fire-fighting equipment for alternatively powered vehicles shall be ensured.

**.2** where vehicles powered by compressed natural gases or hydrogen are carried, the hazards associated with accumulation of flammable gases and gases lighter than air under ceilings need to be addressed.

**.3** pipes with combustible hydraulic oil should be protected from damage. Hydraulic oil from a damaged pipeline in contact with a source of ignition, for example, a refrigerating unit of a truck working during the voyage, can cause a fire.

**2.2.3.6.2** Fire detection and methods/measures to ensure fire safety:

**.1** addressable fixed fire detection and alarm systems;

**.1.2** if a fixed water-based deluge system is used for ro-ro spaces and special category spaces then a fire detection and alarm system addressable to the same sections of the deluge systems should be arranged;

**.1.3** in the design of the fire detection alarm system (refer to **4.2.1.1**) it should be designed with a system interface which provides logical and unambiguous presentation of the information, to allow a quick and correct understanding and decision-making. In particular, the alarm system section numbering should coincide with the sections of other systems, such as fixed water-based fire-extinguishing system or television surveillance system, if available;

**.2** video monitoring;

**.2.1** television surveillance systems can be effective for rapid confirmation of a fire after activation of fire alarms, as well as rapid execution of related actions after the confirmation of fire. This supports the activation of the correct deluge section, as well as manual fire-fighting;



**.2.2** effective television surveillance systems should be provided in ro-ro and special category spaces for continuous video monitoring of these spaces and be provided with immediate playback capability to allow for quick identification of fire location, as far as practicable. Continuous monitoring of the video image by the crew needs not be ensured;

**.3** fire detection in open ro-ro spaces.

in open ro-ro spaces on all ro-ro passenger ships, if smoke detectors are installed (refer to **4.2.1.6**), they should be supplemented with other effective means of detection e.g. flame detectors, heat detectors;

**.4** fire detection on weather decks.

A fixed fire detection and fire alarm system should be provided for weather decks intended for the carriage of vehicles. The fixed fire detection system should be capable of rapidly detecting the onset of fire on the weather deck.

The type of detectors, spacing, and location should be to the satisfaction of the Register taking into account the effects of weather, cargo obstruction and other relevant factors. Different settings may be used for specific operation sequences, such as during loading or unloading and during voyage, in order to reduce the false alarms;

**.5** alarm system design and integration.

Alarm notifications should follow a consistent alarm presentation scheme (wording, vocabulary, colour, and position) and that alarms are immediately recognizable on the bridge and not compromised by noise or poor placing. The interface should provide alarm addressability to allow the crew to identify the alarm history, the most recent alarm, and the means to suppress alarms while ensuring the alarms with ongoing trigger conditions are still clearly visible.

**.6** signage and markings for effective identification and localization.

For closed vehicle, ro-ro spaces, and special category spaces where fixed pressure water-spraying systems are fitted, they should be provided with suitable signage and marking on deck and vertical boundaries to easily identify the sections of the fixed fire-extinguishing system. Signage and markings should be adapted to typical patterns of crew movement and should not be obstructed by fixed installations. Section number signs should be of photoluminescent material complying with ISO 15370. The section numbering indicated inside the space should be the same as the section valve identification and section identification at the safety centre or continuously manned control station.

**2.2.3.6.3** Extinguishment.

**.1** Additional fire-fighting equipment for ro-ro passenger ships.

**.1.1** ro-ro passenger ships shall be equipped with fire-fighting systems in accordance with **3.1.6**;

**.1.2** fire-fighting equipment and outfit shall be available for rapid firefighting in all ro-ro and special category spaces.

**.2** Positioning of sprinklers and nozzles

MSC.1/Circ.1430/Rev.1 on Revised guidelines for the design and approval of fixed water-based fire-fighting systems for ro-ro spaces and special category spaces should be referred to with regard to functional requirements for positioning of sprinklers and nozzles to provide satisfactory performance with respect to both activation time and water distribution.

Fixed water-based fire-fighting system shall comply with the requirements of **3.4**.

**.3** Fixed fire-extinguishing measures on weather decks.

Additional fire-extinguishing measures such as fire monitors and drainage systems may be considered on weather decks. Remotely controlled fire monitors may allow for safe operation of the monitors, but where suitable, manually operated fire monitors may also be used.

**2.2.3.6.4** Structural fire protection.

**.1** Fire integrity of ro-ro decks and decks in special category spaces.

The fire integrity of ro-ro decks separating ro-ro spaces should be at least A-30 (refer also to **2.2.3.2**).

**.2** Types of ro-ro spaces.

Vehicles spaces and ro-ro spaces should be either closed ro-ro spaces or weather decks.

**2.2.3.6.5** Integrity of life-saving appliances and evacuation.

**.1** Ro-ro passenger ships shall be equipped with life-saving appliances and embarkation stations in accordance with the requirements of International Life-Saving Appliance (LSA) Code 1996, with further amendments.

**.2** The following safety distances (measured horizontally) are recommended to avoid jeopardizing life-saving appliances and embarkation stations in case of fire in ro-ro and special category spaces):

**.2.1** survival craft and marine evacuation systems stowed and in a position to be deployed:



**.2.1.1** more than 6 m from a cargo space side opening; and

**.2.1.2** more than 8 m from cargo on weather deck;

**.2.2** survival craft embarkation stations and muster stations located:

**.2.2.1** more than 6 m away from a cargo space side opening; and

**.2.2.2** more than 13 m from cargo on weather deck.

**.3** Equivalent arrangements to the satisfaction of the Register, providing at least the same level of protection, could be considered.

**2.2.4 Doors, windows and sidescuttles.**

**2.2.4.1** Except hatches between the cargo spaces, special category spaces, storerooms and baggage rooms, as well as between such spaces and open decks, all openings shall be provided with permanent closing appliances, having at least such fire integrity as the divisions, in which they are fitted.

Construction of doors and doorframes in the bulkheads of "A" class with locking devices shall provide the same fire integrity and smoke and flame tightness as the bulkheads, in which those doors are fitted as determined in compliance with the FTP Code. Doors approved without the sill being part of the frame, which are installed on or after 1 July 2010, shall be installed such that the gap under the door does not exceed 12 mm. A non-combustible sill shall be installed under the door such that floor coverings do not extend beneath the closed door. Each door fitted in "A" class division shall be capable of being opened and closed manually from both sides of the bulkhead by one person only.

Fire doors in main vertical bulkheads, galley boundaries and stairway enclosures other than power-operated watertight doors and those which are normally locked, shall satisfy the following requirements:

**.1** the doors shall be self-closing and be capable of closing with an angle of inclination of up to 3,5° opposing closure;

**.2** the approximate time of closure for hinged fire doors shall be no more than 40 s and no less than 10 s from the beginning of their movement with the ship in the upright position.

The approximate uniform rate of closure for sliding fire doors shall be no more than 0,2 m/s and no less than 0,1 m/s from the beginning of their movement with the ship in the upright position;

**.3** the doors shall be capable of remote release from the continuously manned central control station, either simultaneously or in groups and shall be capable of release also individually from a position at both sides of the door. Release switches shall have an on-off function to prevent automatic resetting of the system;

**.4** hold-back hooks not subject to central control station release are prohibited;

**.5** a door closed remotely from the central control station shall be capable of being re-opened at both sides of the door by local control. After such local opening, the door shall automatically close again;

**.6** indication shall be provided at the fire door indicator panel in the continuously manned central control station whether each of the remote-released doors is closed;

**.7** the release mechanism shall be so designed that the door will automatically close in case of disruption of the control system or main source of power;

**.8** local power accumulators for power-operated doors shall be provided in the immediate vicinity of the doors to enable the doors to be operated after disruption of the control system or main source of electrical power at least ten times (fully opened and closed) using the local controls;

**.9** disruption of the control system or main source of electrical power of one door shall not impair the safe functioning of other doors;

**.10** remote-released sliding or power-operated doors shall be equipped with an alarm that sounds for at least 5 s but no more than 10 s after the door is released from the central control station and before the door begins to move and continues sounding until the door is completely closed;

**.11** a door designed to re-open upon contacting an object in its path shall re-open not more than 1 m far from the point of contact;

**.12** double-leaf doors equipped with a latch necessary to their fire integrity shall have a latch that is automatically activated by the operation of the doors when released by the control system;

**.13** doors giving direct access to special category spaces which are power-operated and automatically closed need not be equipped with the alarms and remote-release mechanisms required in **2.2.4.1.3** and **2.2.4.1.10**;

**.14** the components of the local control system shall be accessible for maintenance and adjusting; and

**.15** power-operated doors shall be provided with a control system of an approved type which shall be able to operate in case of fire, this being determined in accordance with the FTP Code. This system shall satisfy the following requirements:

the control system shall be able to operate the door at the temperature of at least 200°C for at least 60 min, served by the power supply;

the power supply for all other doors not subject to fire shall not be impaired;

at temperatures exceeding 200°C the control system shall be automatically isolated from the power supply and shall be capable of keeping the door closed up to at least 945°C.

**2.2.4.2** Except watertight doors, weathertight doors (semi watertight doors), doors leading to the open decks, and doors required to be adequately gastight, all "A" class doors located in stairways, public spaces and main vertical zone bulkheads in escape routes shall be equipped with a self-closing hose port of material, construction and fire integrity which is equivalent to the door into which it is fitted, and shall be 1506150 mm square opening with the door closed and shall be inset into the lower edge of the door, opposite the door hinges, or in the case of sliding doors, nearest the opening.

**2.2.4.3** Doors and doorframes in "B" class divisions and their locking devices shall ensure the same fire integrity as the divisions where they are installed in accordance with the FTP Code, except that ventilation openings may be permitted in the lower portion of such doors. If such ventilation openings are located in the door or under it, their total net area shall not exceed 0,05 m<sup>2</sup>. Alternatively, pressurebalancing ventilation duct made of non-combustible material is allowed to be arranged between the cabin and the corridor, and located below sanitary room if an area of its cross section does not exceed 0,05 m<sup>2</sup>.

All such openings shall be fitted with grills made of non-combustible material. Doors shall be noncombustible.

Doors approved without the sill being part of the frame, which are installed on or after 1 July 2010, shall be installed such that the gap under the door does not exceed 25 mm. Cabin doors in "B" class divisions shall be of the self-closing type and shall have no hold-backs.

**2.2.4.4** For ships carrying not more than 36 passengers, windows facing survival craft and escape slide, embarkation areas and windows situated below such areas shall have fire integrity at least equal to "A-0" class.

For ships carrying more than 36 passengers, windows facing survival craft and life-saving appliances, embarkation and assembly stations, external stairs and open decks used for escape routes, and windows situated below liferaft and escape slide embarkation areas shall have fire integrity as required in Table 2.2.1.3-1.

Where automatic dedicated sprinkler heads are provided for windows, "A-0" windows may be accepted as equivalent. Dedicated sprinkler heads shall be located above windows in addition to the conventional ceiling sprinklers or these shall be conventional ceiling sprinkler heads arranged in such a manner that a window is protected by an average application rate of at least 5 l/min per 1 m<sup>2</sup>, and the square of a window shall be included into calculation of the area of coverage or these may be water-mist nozzles complying with the requirements of IMO resolution IMO A.800(19) as amended by MSC.265(84) and MSC.284(86).

Windows located in the ship's side below the lifeboat embarkation areas shall have the fire integrity at least equal to "A-0" class.

All windows and side scuttles in bulkheads within accommodation and service spaces, and control stations, except those subject to provisions of **2.2.4.5** and **2.2.4.8**, shall be fitted so as to ensure that fire integrity of the bulkheads they are fitted in is not impaired, which is determined in accordance with the FTP Code. Despite the requirements of Tables 2.2.1.3-1, 2.2.1.3-2, 2.2.1.5-1 and 2.2.1.5-2, windows and side scuttles in the outer bulkheads of accommodation spaces, service spaces and control stations shall have frames made of steel or other equivalent material and meet the requirements of **7.2.2.4**, Part III "Equipment, Arrangements and Outfit".

**2.2.4.5** The requirements for "A" class fire integrity of ship external boundaries do not apply to glassed bulkheads, windows and side scuttles, provided that **2.2.4.4** does not contain the requirement that such boundaries shall be of "A" class. The requirements for "A" class fire integrity of the outer boundaries of a ship shall not apply to exterior doors, except for those in superstructures and deckhouses facing life-saving appliances, embarkation and external muster station areas, external stairs and open decks used for escape routes. Stairway enclosure doors need not meet this requirement.

**2.2.4.6** In passenger ships carrying not more than 36 passengers, it is allowed to use combustible materials for manufacture of doors separating cabins from internal individual sanitary spaces such as showers.

**2.2.4.7** Doors to machinery spaces of category A, other than power-operated watertight doors shall be arranged to ensure their positive closing by power operated closings arrangements or by fitting self-closing doors capable of being closed with an angle of inclination of up to 3,58 opposite to the door closure and equipped with locking device and remotely controlled release mechanism. Doors for the emergency escape trunks may not to be equipped with locking devices and remotely controlled release mechanisms.

Doors closure controls, required by **2.1.4.2.3**, shall be located in one place or centralized at possibly less number of places. These places shall have free access from the open deck.

**2.2.4.8** The requirements for "B" class fire integrity of ship external boundaries do not apply to glassed bulkheads, windows and side scuttles. Such requirements for "B" class fire integrity do not apply to exterior doors in superstructures and deckhouses.

**2.2.4.9** Notwithstanding the requirements of 2.2.4.4, requirements of 2.2.4.9 - 2.2.4.11 apply to ships contracted for the construction on or after January 1, 2020.

**2.2.4.10** For ships carrying more than 36 passengers, windows facing survival craft and life-saving appliances, embarkation and assembly stations, external stairs and open decks used for escape routes, and windows situated below liferaft and escape slide embarkation areas shall have fire integrity as required in Table 2.2.1.3-1.

Where automatic dedicated sprinkler heads are provided for windows, "A-0" windows may be accepted as equivalent. Dedicated sprinkler heads shall be located above windows in addition to the conventional ceiling sprinklers or these shall be conventional ceiling sprinkler heads arranged in such a manner that a window is protected by an average application rate of at least 5 l/min per 1 m<sup>2</sup>, and the square of a window shall be included into calculation of the area of coverage or these may be water-mist nozzles complying with the requirements of IMO resolution IMO A.800(19) as amended by MSC.265(84) and MSC.284(86).

Windows located in the ship's side below the lifeboat embarkation areas shall have the fire integrity at least equal to "A-0" class.

**2.2.4.11** For ships carrying not more than 36 passengers, windows facing survival craft and escape slide, embarkation areas and windows situated below such areas shall have fire integrity at least equal to "A-0" class.

#### **2.2.5 External areas on passenger ships.**

**2.2.5.1** Fire risk of external areas on passenger ships is evaluated in accordance with the provisions of IMO circular MSC.1/Circ.1274.

#### **2.2.6 Casualty threshold, safe return to port and safe areas.**

**2.2.6.1** Passenger ships having length, as defined in the International Convention on Load Lines, 1966 (LL 66), as modified by the Protocol of 1988 relating thereto with further amendments (LL 66/88), of 120 m or more or having three or more main vertical zones, shall comply with the requirements of **2.2.6** in order to meet functional requirements and performance standards for safe areas in case of casualty that does not exceed the casualty threshold.

**2.2.6.2** When fire damage does not exceed the casualty threshold, the ship shall be capable of returning to port while providing a safe area as defined in **1.2**. To be deemed capable of returning to port the fixed fire extinguishing systems, including the fire main system, and the fire detection and fire alarm system shall remain operational in the remaining part of the ship not affected by fire.

**2.2.6.3** The fire main system shall remain operational in all main vertical zones not directly affected by the casualty. Water feed for fire-fighting purposes shall be available to all areas of the ship.

**2.2.6.4** The automatic sprinkler system or any other fixed fire extinguishing system designed to protect an entire space shall be operational in all spaces not directly affected by the casualty.

**2.2.6.5** The fire detection and fire alarm system, including smoke detection system, shall be operational in all spaces not directly affected by the casualty.

**2.2.6.6** Means of access to life-saving appliances shall be provided from each safe area, taking into account that a main vertical zone may not be available for internal transit.

**2.2.6.7** In addition to the requirements of **2.2.6.2**, the following systems, machinery and equipment shall remain operational in the remaining part of the ship not affected by fire:

- .1 propulsion and essential auxiliary machinery;
- .2 steering systems and steering-control systems;
- .3 power-operated watertight doors;
- .4 fuel oil systems for propulsion and essential auxiliary machinery;
- .5 ballast and bilge systems;

.6 internal communication between the bridge, engineering spaces, safety centre, fire-fighting and damage control teams, and as required for passenger and crew notification and mustering; internal communication shall be provided by effective fixed or portable means;

.7 flooding detection systems;

.8 navigation lights in accordance with the requirements of Convention on the International Regulations for Preventing Collisions at Sea, 1972 (COLREG 72) ;

**.9** GMDSS radio equipment (radio communication by GMDSS radio equipment shall be provided or, if the main GMDSS radio equipment is out of service due to casualty, the distress alert initiating shall be provided on the VHF frequencies including two-way VHF radiotelephone apparatus for communications with aircrafts);

**.10** navigational equipment essential for navigation, indicating the ship location and collision risk assessment.

**2.2.6.8** The systems, machinery and equipment specified in **2.2.6.2** and **2.2.6.7** shall remain operational in case of flooding of any watertight compartment.

**2.2.6.9** If systems are needed to fight with fire and flooding which are not specified in **2.2.6.2** and **2.2.6.7** they shall comply with the requirement of **2.2.6.7**.

**2.2.6.10** Ventilation of safe area(-s) shall comply with the requirements of **2.2.6.7** and **2.2.6.8**.

Ventilation design shall reduce the risk that smoke and hot gases could affect the use of the safe area(s).

**2.2.6.11** Power supply of electrical equipment specified in **2.2.6.7** and **2.2.6.13** shall be provided to ensure their simultaneous operation.

**2.2.6.12** The safe area(s) shall generally be internal space(s); however, the use of an external space as a safe area may be allowed taking into account any restriction due to the area of operation and relevant expected environmental conditions.

**2.2.6.13** The safe area(s) shall provide all occupants with the following basic services to ensure that the health of passengers and crew is maintained:

- .1** sanitation;
- .2** fresh water;
- .3** food;
- .4** alternate space for medical care;
- .5** shelter from the weather;
- .6** means of preventing heat stress and hypothermia;
- .7** light;
- .8** ventilation.

**2.2.7 Systems to remain operational after a fire casualty.**

**2.2.7.1** Passenger ships having length, as defined in the International Convention on Load Lines, 1966 (LL 66), as modified by the Protocol of 1988 relating thereto with further amendments (LL 66/88), of 120 m or more, or having three or more main vertical zones shall comply with the requirements of **2.2.7** to provide the systems operability if the casualty threshold is exceeded.

**2.2.7.2** In case any one main vertical zone is unserviceable due to fire, the fire main system shall be so arranged and segregated as to remain operational for at least 3 h based on the assumption of no damage outside the unserviceable main vertical zone. In particular, the fire main system shall remain operational in all main vertical zones not directly affected by the casualty. The fire main system is not required to remain operational within the unserviceable main vertical zones.

**2.2.7.3** Cabling and piping within a trunk constructed to an "A-60" class shall remain intact and serviceable while passing through the unserviceable main vertical zone. An equivalent degree of protection for cabling and piping may be approved by the Register.

**2.2.7.4** In addition to **2.2.7.2** the following systems, machinery and equipment shall be so arranged and segregated as to remain operational for at least 3 h based on the assumption of no damage outside the unserviceable main vertical zone:

- .1** bilge systems for removal of fire-fighting water;
- .2** lighting along escape routes, at assembly stations and at embarkation stations of life-saving appliances;
- .3** low location lighting of escape routes with electrical power supply;
- .4** internal communications (in support of fire-fighting as required for passenger and crew notification and evacuation); internal communication shall be provided by effective fixed or portable means;
- .5** GMDSS radio equipment (radio communication by GMDSS radio equipment shall be provided or, if the main GMDSS radio equipment is out of service due to casualty, the distress alert initiating shall be provided on the VHF frequencies including two-way VHF radiotelephone apparatus for communications with aircrafts).

**2.2.7.5** The systems, machinery and equipment specified in **2.2.7.4** are not required to remain operational within the unserviceable main vertical zones.

**2.2.7.6** Power supply of electrical equipment for evacuation from ship including life-saving appliances, as well as of systems, machinery and equipment specified in **2.2.7.4** shall be provided to ensure their simultaneous operation.

**2.2.8 Safety centre on passenger ships (refer also to IMO circular MSC.1/Circ.1368).**

**2.2.8.1** Passenger ships shall have on board a safety centre, as defined in 1.2, complying with the requirements of **2.2.8**.

**2.2.8.2** The safety centre shall either be a part of the navigation bridge or be located in a separate room adjacent to and having direct access to the navigation bridge.

**2.2.8.3** Means of communication between the safety centre, the storage room(s) for fire extinguishing system(s) and fire equipment lockers shall be provided.

**2.2.8.4** According to MSC.1/Circ.1368 the functionality, i.e. activation, control, monitoring or combination thereof, of the following safety systems shall be available from the safety centre: fire detection and fire alarm system, sprinkler and equivalent systems, water-based systems for machinery spaces, fixed local application fire extinguishing systems as well as fire pumps and emergency fire pumps.

**2.2.8.5** In addition to **2.2.8.3** means of communication between the safety centre, the central control station, the navigation bridge, the engine control room shall be provided.

**2.2.8.6** According to IMO circular MSC.1/Circ.1368 in addition to 2.2.8.4 the functionality, i.e. activation, control, monitoring or combination thereof, of the safety systems listed below shall be available from the safety centre:

- .1 all powered ventilation systems;
- .2 atrium smoke extraction system;
- .3 indication of closing watertight and fire doors;
- .4 general emergency alarm system;
- .5 public address system;
- .6 low location lighting of escape routes with electrical power supply;
- .7 indicators for shell doors, loading doors and other closing appliances;
- .8 flooding detection system.

**2.3 CARGO SHIPS**

**2.3.1** The requirements of this Chapter are additional to those set out in **2.1** and apply to cargo ships of 500 gross tonnage and upwards.

**2.3.2** In way of accommodation and service spaces and control stations one of the following methods of protection shall be adopted:

Method IC: construction of internal subdivision bulkheads of non-combustible "B" or "C" class divisions, generally without installation in the accommodation and service spaces of the automatic sprinkler fire extinguishing system and fire detection and fire alarm system;

Method IIC: the fitting of an automatic sprinkler system and fire detection and fire alarm system in all spaces in which fire might be expected to originate, generally with no restriction on the type of internal bulkheads; or

Method IIIC: the fitting of a fixed fire detection and fire alarm system of approved type complying with requirements of **4.1** and **4.2** in spaces where fire might develop, generally with no restriction on the class of internal subdivision bulkheads, except that in no case shall the area of any accommodation space bounded by "A" or "B" class division exceeds 50 m<sup>2</sup>. Consideration may be given by the Register to increasing this area for public spaces.

The requirements on using non-combustible materials for the construction and insulation of bulkheads bounding machinery spaces, control stations, service spaces, etc. as well as protection of above mentioned trunks and stairways enclosures are common for all three methods described above.

**2.3.3** The minimum fire integrity of the bulkheads and decks separating adjacent spaces shall be as prescribed in Tables 2.3.3-1 and 2.3.3-2.

For determining the appropriate fire integrity standards to be applied to divisions between adjacent spaces, the spaces are classified according to their fire risk as follows:

(1) *control stations*: spaces accommodating emergency sources of electrical power and lighting; wheelhouse and navigation room; spaces accommodating ship radio equipment; fire stations; main machinery control room if it is located outside machinery space; spaces accommodating centralized fire alarm system;

(2) *corridors and lobbies*;

(3) *accommodation spaces* in accordance with **1.5.2**, except corridors;

(4) *stairways*;

interior stairways, lifts, totally enclosed emergency escape trunks and escalators (other than those wholly contained within the machinery spaces) and enclosures thereto.

A stairway which is enclosed only at one level shall be regarded as part of the space from which it is not separated by a fire door;

(5) *service spaces (low risk)*:

storerooms not having provisions for the storage of flammable liquids and having areas less than 4 m<sup>2</sup>, drying rooms, laundries and refrigerated provision storerooms insulated with non-combustible materials;

spaces accommodating electrical distribution boards having an area of less than 4 m<sup>2</sup>;

(6) *machinery spaces of category A*:

spaces as defined in 1.2, Part VII "Machinery Installations";

incinerator and combined incinerator/waste stowage spaces, and the flue uptakes from such spaces (refer to 2.1.5.9).

(7) *other machinery spaces*:

machinery spaces excluding those specified in (6) and spaces accommodating electrical equipment (automatic telephone stations, spaces for air conditioning ducts);

(8) *cargo spaces*:

all spaces used for carriage of cargoes (including cargo tanks for oily products) as well as trunkways and hatchways to such spaces;

(9) *service spaces (greater fire risk)*: galleys and pantries containing appliances for hot food preparation, saunas, paint lockers and storerooms with an area of 4 m<sup>2</sup> and over, spaces for storage of flammable liquids, workshops and similar spaces, which are not part of machinery spaces;

refrigerated provision storerooms insulated with combustible materials;

waste stowage spaces and garbage chutes connected thereto;

(10) *open decks*:

open deck spaces and enclosed promenades having no fire risk. This means that their furnishings shall be restricted to deck furniture. In addition, such spaces shall be naturally ventilated by permanent openings:

air spaces (spaces outside superstructures and deckhouses);

(11) *ro-ro cargo spaces and motor vehicles spaces* as defined in 1.5.4.3 and 1.5.4.4.

**Table 2.3.3-1 Fire integrity of bulkheads separating adjacent spaces**

Spaces	2	3	4	5	6	7	8	9	10	11	12	13
Control stations	1)	A-0 <sup>1</sup>	A-0	A-60	A-0	A-15	A-60	A-15	A-60	A-60	*	A-60
Corridors and lobbies	2)		C	B-0	A-0 <sup>2</sup> B-0	B-0	A-60	A-0	A-0	A-0	*	A-30
Accommodation spaces	3)			C <sup>3,4</sup>	A-0 <sup>2</sup> B-0	B-0 <sup>2</sup>	A-60	A-0	A-0	A-0	*	A-30
Stairways	4)				A-0 <sup>2</sup> B-0	A-0 <sup>2</sup> B-0	A-60	A-0	A-0	A-0	*	A-30
Service spaces (low risk)	5)					C	A-60	A-0	A-0	A-0	*	A-0
Machinery spaces of category A	6)						*	A-0	A-0 <sup>5</sup>	A-60	*	A-60 <sup>6</sup>
Other machinery spaces	7)							A-0 <sup>7</sup>	A-0	A-0	*	A-0
Cargo spaces	8)								*	A-0	*	A-0
Service spaces (high risk)	9)									A-0 <sup>7</sup>	*	A-30
Open decks	10)										*	A-0
Special category spaces	11)										*	A-30 <sup>8</sup>

**Table 2.3.3-2 Fire integrity of decks separating adjacent spaces**

Spaces	2	3	4	5	6	7	8	9	10	11	12	13
Control stations	1)	A-0	A-0	A-0	A-0	A-0	A-60	A-0	A-0	A-0	*	A-60
Corridors and lobbies	2)	A-0	*	*	A-0	*	A-60	A-0	A-0	A-0	*	A-30
Accommodation spaces	3)	A-60	A-0	*	A-0	*	A-60	A-0	A-0	A-0	*	A-30

Stairways	4)	A-0	A-0	A-0	*	A-0	A-60	A-0	A-0	A-0	*	A-30
Service spaces (low risk)	5)	A-15	A-0	A-0	A-0	*	A-60	A-0	A-0	A-0	*	A-0
Machinery spaces of category A	6)	A-60	A-60	A-60	A-60	A-60	*	A-60 <sup>9</sup>	A-30	A-60	*	A-60
Other machinery spaces	7)	A-15	A-0	A-0	A-0	A-0	A-0	*	A-0	A-0	*	A-0
Cargo spaces	8)	A-60	A-0	A-0	A-0	A-0	A-0	A-0	*	A-0	A-0	A-0
Service spaces (high risk)	9)	A-60	A-30	A-30	A-30	A-30	A-60	A-0	A-0	A-0 <sup>7</sup>	*	A-30
Open decks	10)	*	*	*	*	*	*	*	*	*	-	A-0 <sup>8</sup>
Special category spaces	11)	A-60	A-30	A-30	A-30	A-30	A-60	A-0	A-0	A-30	A-0 <sup>8</sup>	A-30 <sup>8</sup>

Footnotes to Tables. 2.3.3-1, 2.3.3-2.

<sup>1</sup> Bulkheads separating the wheelhouse, chartroom and radio room from each other may be "B-0" class..

<sup>2</sup> For clarification as to which applies, refer to 2.1.4.3.

<sup>3</sup> Doors separating cabins from individual sanitary accommodation may be constructed of combustible materials in *method IC* fire protection. No special requirements are imposed upon bulkheads in *methods IIC* and *IIIC*.

<sup>4</sup> In case of *method IIIC* bulkheads of "B-0" class shall be provided between spaces or groups of spaces of 50 m<sup>2</sup> and over in area.

<sup>5</sup> For cargo spaces intended for carriage of dangerous goods refer to 7.2.12.

<sup>6</sup> "A-0" class may be used if no dangerous goods are intended to be carried.

<sup>7</sup> Where spaces are used for the same purpose, divisions between them need not be fitted.

<sup>8</sup> Ships built before 1 July 2014 shall meet at least the preliminary requirements applicable during the construction of the ship

<sup>9</sup> Where other machinery spaces of category (7) are the spaces of low fire risk, i.e. they do not contain machinery operating on fuel oil or having a pressure lubrication systems, "A-0" class divisions are permitted (refer to Table 2.3.3-2).

<sup>1</sup> Where an asterisk appears in the tables the division shall be of steel or equivalent but is not required to be of "A" class. However, if in the deck except for the decks in a space of category (10), there are penetrations for electric cables, piping and ventilation ducts, such penetrations shall be flame and smoke tight. Divisions between control stations (emergency generators) and open decks may have air intake openings without closing appliances, except cases when fixed gas fire-fighting system is installed.

<sup>2</sup> Small enclosed spaces indoors, having the area of openings in bounding structures, connected to the space, less than 30%, are considered as separate spaces.

Fire integrity of divisions and decks bounding such small spaces shall comply with the Tables of this paragraph of the Rules.

**2.3.4** Linings, ceilings, draught stops and their associated grounds shall be made of non-combustible materials:

in accommodation and service spaces, and in control stations, if protection *method IC* is used;

in corridors and stairway enclosures serving accommodation and service spaces, and control stations, if protection *methods IIC* and *IIIC* are used.

**2.3.5** Within accommodation spaces, bulkheads not required to be "A" or "B" class divisions shall be:

.1 at least "C" class division in *method IC* fire protection;

.2 not subject to any restrictions, except in cases where "C" class bulkheads are required in accordance with Table 2.3.3-1 in *method IIC* fire protection;

.3 not subject to any restrictions except that in no case shall the area of any accommodation space or spaces bounded by "A" or "B" class divisions exceed 50 m<sup>2</sup> (except in cases where "C" class bulkheads are required in accordance with Table 2.3.3-1), in *method IIIC* fire protection.

Consideration may be given by the Register to increasing this area for public spaces.

If the *IC method* of protection has been used while ship construction, application of combustible materials may be allowed for doors separating cabins from internal sanitary spaces such as showers.

**2.3.6** The doors installed in the bulkheads bounding machinery spaces of category A shall be self-closing and adequately gastight. "A" class doors approved without the sill being part of the frame, which are installed on or after 1 July 2010, shall be installed such that the gap under the door does not exceed 12 mm, and a non-combustible sill shall be installed under the door such that floor coverings do not extend beneath the closed door.

"B" class doors approved without the sill being part of the frame, which are installed on or after 1 July 2010, shall be installed such that the gap under the door does not exceed 25 mm.

**2.3.7** The doors required to be self-closing shall not be equipped with locking devices. However, locking devices may be used equipped with remotely controlled release mechanisms.

**2.3.8** In the corridor bulkheads ventilation openings may be permitted in and under the doors of cabins and public spaces. Ventilation openings are also permitted in "B" class doors leading to sanitary rooms, studies, pantries, lockers and storerooms. Except for the permitted below, openings shall be provided in the lower portion of such doors only. If such ventilation opening is located in or under the door, the total net area of such opening shall not exceed 0,05 m<sup>2</sup>. Alternatively, balancing duct made of non-combustible material and located below sanitary room is allowed to be arranged between the cabin and the corridor if an area of its cross section does not exceed 0,05 m<sup>2</sup>. Ventilation openings except the ones located under the door shall be fitted with grills made of non-combustible material.

**2.3.9** All bulkheads required to be "B" class divisions within accommodation spaces, shall extend from deck to deck and to the hull shell or other boundaries. However, if the continuous "B" class ceilings or linings are fitted on both sides of the bulkhead the bulkhead may terminate at the continuous ceiling or lining.

**2.3.10** For the purpose of application of the requirements of **2.1.1.7**, **2.1.1.8** and **2.1.1.10** it is necessary to follow Fig. 2.3.10 and Table 2.3.10 subgroup 1 for the *method IC*, subgroup 2 for the *methods IIC* and *IIC*.

**Table 2.3.10**

Nos.	Requirements to materials Structural member	Non-combustibility (refer to <b>2.3.4</b> )	Non-combustibility (refer to <b>2.1.1.5</b> )	Low Flame-spread (refer to <b>2.1.1.8</b> )	Total volume of combustible materials (refer to <b>2.1.1.10.1</b> )	Calorific value (refer to <b>2.1.1.10</b> )	Smoke and toxic vapors generation (refer to <b>2.1.1.7</b> )	Hardened combustibility (refer to <b>2.1.1.6</b> )
<b>IC</b>								
1.1	Moldings				x			
1.2	Panels	x						
1.3	Painted surfaces, linings, textiles, films			x	x	x	x	
1.4	Painted surfaces, linings, textiles, films			x	x	x	x	
1.5	Decorations				x		x <sup>2</sup>	
1.6	Painted surfaces, linings, textiles, films				x	x	x <sup>2</sup>	
1.7	Plinth				x			
1.8	Insulation		x <sup>1</sup>					
1.9	Surfaces and paints in concealed and inaccessible places			x				
1.10	Draught prevention seals	x						
1.11	Furring	x		x				
1.12	Linings	x						
1.13	Primary deck covering						x	x
1.14	Floor covering			x <sup>3</sup>			x <sup>3</sup>	
1.15	Scuttle frame	x						
1.16	Scuttle frame surface			x <sup>3</sup>	x	x	x <sup>3</sup>	
1.17	Scuttle frame surface in concealed and inaccessible places			x				
1.18	Ceiling panel	x						
<b>IIC and IIC</b>								
2.1	Moldings				x			
2.2	Panels	x <sup>4</sup>						
2.3	Painted surfaces, linings, textiles, films			x	x	x	x	
2.4	Painted surfaces, linings, textiles, films			x	x <sup>6</sup>	x <sup>5</sup>	x	
2.5	Decorations				x <sup>6</sup>		x <sup>2</sup>	



2.6	Painted surfaces, linings, textiles, films				$x^6$	$x^5$	$x^2$	
2.7	Plinth				$x^6$			
2.8	Insulation		$x^1$					
2.9	Surfaces and paints in concealed and inaccessible places	$x^4$		$x^2$				
2.10	Draught prevention seals	$x^4$		$x$				
2.11	Furring	$x^4$						
2.12	Linings						$x$	$x$
2.13	Primary deck covering			$x^3$			$x^4$	
2.14	Floor covering	$x^4$						
2.15	Scuttle frame			$x^6$	$x^6$	$x^5$	$x^4$	
2.16	Scuttle frame surface			$x$				
2.17	Scuttle frame surface in concealed and inaccessible places	$x^4$						

<sup>1</sup> Vapor barriers used for coating of the cooling systems piping (refer to **2.1.15**) may be combustible, provided they are low flame-spread.

<sup>2</sup> Applied to paints, varnishes and other coatings.

<sup>3</sup> In corridors and stairways enclosures.

<sup>4</sup> Only in corridors and stairways enclosures servicing accommodation and service spaces and control stations.

<sup>5</sup> When combustible materials are fitted on non-combustible bulkheads, ceilings and linings in accommodation and service spaces.

<sup>6</sup> Applied to such accommodation and service spaces, which are bounded by non-combustible bulkheads, ceilings and linings.

<sup>7</sup> Non-combustible - a characteristic applicable to deck plating (primary or plating in general, if they are used in accommodation and service spaces and control stations or on the balconies of passenger ships cabins), which shall be made of an approved material that is not flammable or non-hazardous regarding the release of toxic or explosive substances at elevated temperatures, as determined by the FTP Code 2010.

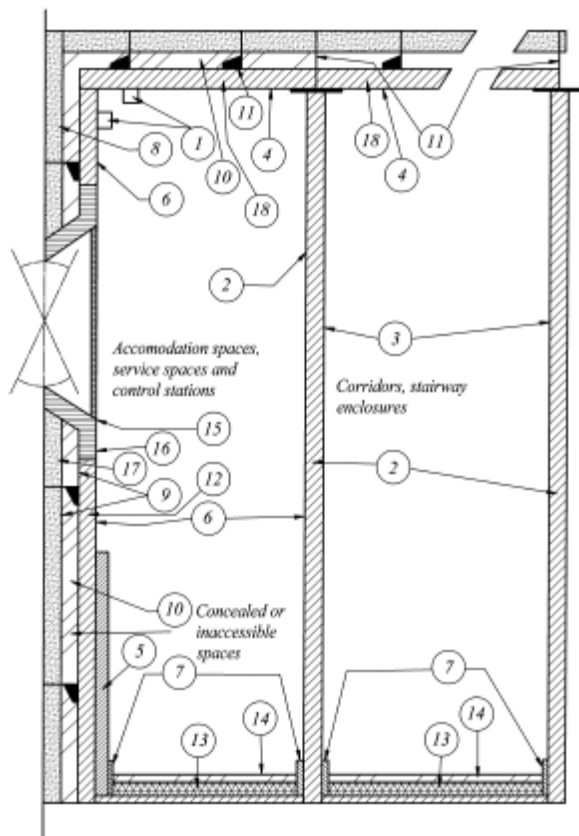

Fig. 2.3.10 Structural members

1. Moldings; 2. Panels; 3. Painted surfaces, linings, textiles, films; 4. Painted surfaces, linings, textiles, films; 5. Decorations; 6. Painted surfaces, linings, textiles, films; 7. Plinth; 8. Insulation; 9. Surfaces and paints in concealed and inaccessible places; 10. Draught prevention seals; 11. Furring; 12. Linings; 13. Primary deck covering; 14. Floor covering. 15. Scuttle frame; 16. Scuttle frame surface; 17. Scuttle frame surface in concealed and inaccessible places; 18. Ceiling panel.

## 2.4 OIL TANKERS

2.4.1 The requirements of this Chapter are additional to those set out in 2.1 and 2.3 (except for 2.3.3) when only *method IC* fire protection is adopted and apply to oil tankers and combination carriers of 500 gross tonnage and upwards.

2.4.2 The minimum fire integrity of bulkheads and decks separating adjacent spaces shall be as prescribed in Tables 2.4.2-1 and 2.4.2-2 with regard to the following.

For determining the appropriate fire integrity standards to be applied to divisions between adjacent spaces, the spaces are classified according to their fire risk as follows:

(1) *control stations*: spaces accommodating emergency sources of electrical power and lighting; wheelhouse and navigation room; spaces accommodating ship radio equipment; fire stations;

main machinery control room if it is located outside machinery space; spaces accommodating centralized fire alarm system;

(2) *corridors and lobbies*;

(3) accommodation spaces as defined in 1.5.2, except corridors;

(4) *stairways*:

interior stairways, lifts, totally enclosed emergency escape trunks and escalators (other than those wholly contained within the machinery spaces) and enclosures thereto.

A stairway which is enclosed only at one level shall be regarded as part of the space from which it is separated by a fire door;

(5) *service spaces (low risk)*:

storerooms having areas less than 4 m<sup>2</sup> and not having provisions for the storage of flammable liquids, drying rooms, laundries and refrigerated provision storerooms insulated with non-combustible materials; spaces accommodating electrical distribution boards having an area of less than 4 m<sup>2</sup>;

(6) *machinery spaces of category A*:

spaces as defined in 1.2, Part VII "Machinery Installations";

incinerator and combined incinerator/ waste stowage spaces, and the flue uptakes from such spaces (refer to 2.1.5.9);

(7) *other machinery spaces*:

machinery spaces excluding spaces referred to in (6) and spaces accommodating electrical equipment (automatic telephone stations, spaces for air conditioning ducts);

(8) cargo pump rooms as defined in 1.5.7.1;

(9) service spaces (greater fire risk): galleys and pantries containing appliances for hot food preparation, saunas, paint lockers and storerooms with an area of 4 m<sup>2</sup> and over, spaces for storage of flammable liquids, workshops and similar spaces, which are not part of machinery spaces;

refrigerated provision storerooms insulated with combustible materials;

waste stowage spaces and garbage chutes connected thereto;

(10) *open decks*:

open deck spaces and enclosed promenades having no fire risk. This means that their furnishings shall be restricted to deck furniture. In addition, such spaces shall be naturally ventilated by permanent openings.

air spaces (spaces outside superstructures and deckhouses);

**Table 2.4.2-1 Fire integrity of bulkheads separating adjacent spaces**

Spaces											
1	2	3	4	5	6	7	8	9	10	11	12
Control stations	1)	A-0 <sup>1</sup>	A-0	A-60	A-0	A-15	A-60	A-15	A-60	A-60	*
Corridors and lobbies	2)		C	B-0	A-0 B-0 <sup>2</sup>	B-0	A-60	A-0	A-0	A-0	*
Accommodation spaces	3)			C	A-0 B-0 <sup>2</sup>	B-0	A-60	A-0	A-0	A-0	*

Stairways	4)				A-0 B-0 <sup>2</sup>	A-0 B-0 <sup>2</sup>	A-60	A-0	A-0	A-0	*
Service spaces (low risk)	5)					C	A-60	A-0	A-0	A-0	*
Machinery spaces of category A	6)						*	A-0	A-0 <sup>3</sup>	A-60	*
Other machinery spaces	7)							A-0 <sup>4</sup>	A-0	A-0	*
Pump rooms	8)								*	A-0	*
Service spaces (high risk)	9)									A-0 <sup>4</sup>	*
Open decks	10)										*

**Table 2.4.2-2 Fire integrity of decks separating adjacent spaces**

Spaces												
1	2	3	4	5	6	7	8	9	10	11	12	
Control stations	1)	A-0	A-0	A-0	A-0	A-0	A-60	A-0	-	A-0	*	
Corridors and lobbies	2)	A-0	*	*	A-0	*	A-60	A-0	-	A-0	*	
Accommodation spaces	3)	A-60	A-0	*	A-0	*	A-60	A-0	-	A-0	*	
Stairways	4)	A-0	A-0	A-0	*	A-0	A-60	A-0	-	A-0	*	
Service spaces (low risk)	5)	A-15	A-0	A-0	A-0	*	A-60	A-0	-	A-0	*	
Machinery spaces of category A	6)	A-60	A-60	A-60	A-60	A-60	*	A-60 <sup>5</sup>	A-30	A-60	*	
Other machinery spaces	7)	A-15	A-0	A-0	A-0	A-0	A-0	*	A-0	A-0	*	
Pump rooms	8)	-	-	-	-	-	A-0 <sup>3</sup>	A-0	*	-	A-0	
Service spaces (high risk)	9)	A-60	A-0	A-0	A-0	A-0	A-60	A-0	-	A-0 <sup>4</sup>	*	
Open decks	10)	*	*	*	*	*	*	*	*	*	*	*

Footnotes to Tables. 2.3.4-1, 2.3.4-2.

<sup>1</sup> Bulkheads separating the wheelhouse, chartroom and radio room from each other may be "B-0" class.

<sup>2</sup> For clarification as to which applies, refer to 2.1.4.3.

<sup>3</sup> Where bulkheads and decks are penetrated by cargo pump shafts, electric cables, etc. refer to 2.4.8

<sup>4</sup> Where spaces are used for the same purpose, divisions between them need not be fitted

<sup>5</sup> 1 Where other machinery spaces of category (7) are the spaces of low fire risk, i.e. they do not contain machinery operating on fuel oil or having a pressure lubrication systems, "A-0" class divisions are permitted (refer to Table 2.4.2-2)

1 Where an asterisk appears in the tables the division shall be of steel or equivalent but is not required to be of "A" class. However, if in the deck except for the decks in a space of category (10), there are penetrations for electric cables, piping and ventilation ducts, such penetrations shall be flame and smoke tight. Divisions between control stations (emergency generators) and open decks may have air intake openings without closing appliances, except cases when fixed gas fire-fighting system is installed.

2. Small enclosed spaces indoors, having the area of openings in bounding structures, connected to the space, less than 30%, are considered as separate spaces.

Fire integrity of divisions and decks bounding such small spaces shall comply with the Tables of this paragraph of the Rules.

**2.4.3** Exterior boundaries of superstructures and deckhouses enclosing accommodation and including any overhanging decks which support such accommodation, shall be constructed of steel and be "A-60" class for the whole of the portions which face the cargo area and on the outward sides for a distance of 3 m from the end boundary facing the cargo area.

The distance of 3 m shall be measured horizontally and parallel to the centreline of the ship from the boundary facing the cargo area at the each deck level. The insulation above shall be provided up to the underside of navigation bridge deck.

Lower part of the navigation bridge facing the cargo area shall be "A-60" class.

**2.4.4** Arrangement of openings shall meet the requirements of **2.4.4.1 - 2.4.4.3**.

**2.4.4.1** Except as permitted in **2.4.4.2**, access doors, air inlets and openings to accommodation spaces, service spaces, control stations and machinery spaces shall not face the cargo area. They shall be located on the transverse bulkhead not facing the cargo area or on the outboard side of the superstructure or deckhouse at the distance of at least 4 % of the ship length but not less than 3 m from the end of the superstructure or deckhouse facing the cargo area. However, this distance need not exceed 5 m.

Access to forecastle spaces containing sources of ignition may be permitted through doors facing cargo area provided the doors are located outside hazardous areas (refer to **19.2**, Part XI "Electrical Equipment").

**2.4.4.2** The Register may permit access doors in superstructures or deckhouses on transverse bulkheads facing the cargo area or on side bulkheads within 5 m limits specified in **2.4.4.1**, to cargo control rooms and to such service spaces used as provision rooms, storerooms and lockers, provided they do not give access directly or indirectly to any other space containing or providing for accommodation, control stations or service spaces such as galleys, pantries or workshops or similar spaces containing sources of vapour ignition.

Boundaries of such a space shall be of "A-60" class except for the boundary facing the cargo area. Bolted plates for the removal of machinery may be fitted within the limits specified in 2.4.4.1.

Wheelhouse doors and windows may be located within the limits specified in 2.4.4.1 so long as they are designed to ensure that the wheelhouse can be made rapidly and efficiently gastight and vapourtight.

**2.4.4.3** The Register may permit access to a deck foam system room where foam tanks and control station are located within the distances specified in 2.4.4.1 provided the requirements of 2.4.4.2 are fulfilled and the door is located flush with a bulkhead.

**2.4.5** Windows and sidescuttles facing the cargo area and located on the sides of superstructures and deckhouses within the limits specified in 2.4.4.1 shall be of the fixed (non-opening) type. Such windows and sidescuttles, except wheelhouse window, shall be of "A-60" class.

Except that "A-0" class standard is acceptable for windows and sidescuttles outside the limit specified in 2.4.4.1.

**2.4.6** The Register may permit a navigation position to be fitted above the cargo area where this is for navigation purposes only, and it shall be separated from the cargo tank deck by means of an open space with a height of at least 2 m. The fire protection of such a navigation position shall be as required for control stations in 2.4.2 and other provisions, as applicable, of this Part.

**2.4.7** Machinery spaces shall be positioned aft of cargo tanks and slop tanks; they shall also be situated aft of pump rooms and cofferdams, but not necessarily aft of the fuel oil tanks. Any machinery space shall be isolated from cargo tanks and slop tanks by cofferdams, pump rooms, fuel oil tanks, or ballast tanks.

Pump rooms containing pumps and their accessories for ballasting those spaces situated adjacent to cargo tanks and slop tanks, and pumps for fuel oil transfer may be used for isolation of machinery spaces from cargo tanks and slop tanks provided that such pump rooms have the same safety standard as that required for cargo pump rooms. The lower portion of the pump room bulkhead may be recessed into machinery spaces of category A to accommodate pumps. The deck head of the recess may be not more than one third of the moulded depth above the keel. In ships of not more than 25000 t deadweight, for reasons of access and satisfactory piping arrangements and on agreement with the Register, the deck head of the recess may be at a level of up to one half of the moulded depth above the keel.

A cargo tank or a slop tank adjoining machinery spaces by a corner shall be isolated therefrom by a corner cofferdam. The design and dimensions of cofferdams shall comply with the requirements of 2.7.5.2, Part II "Hull".

Corner cofferdams inaccessible for inspection shall be fitted with suitable media.

No cargoes or wastes shall be stowed in cofferdams.

Void space or ballast water tank protecting fuel oil tank as shown in Fig. 2.4.7, need not be considered as a cargo area even though they have a cruciform contact with the cargo oil tank or slop tank. The void space protecting fuel oil tank is not considered as a cofferdam required above. Void spaces may be located as shown in Fig. 2.4.7 even though they have a cruciform contact with the slop tank.

**2.4.8** Pump rooms shall be closed in by gastight bulkheads.

Permanent approved gastight lighting enclosures may be installed in bulkheads and decks separating pump rooms from other spaces. These enclosures are intended for lighting of pump rooms provided that they are sufficiently durable and that fire integrity and gas-tightness of the bulkhead or deck is preserved.

**2.4.9** Control stations, cargo control stations, accommodation and service spaces (except for isolated cargo handling gear lockers) shall be positioned aft of all cargo tanks, slop tanks and spaces isolating cargo or slop tanks from machinery spaces, but not necessarily aft of the fuel oil tanks and ballast tanks, and shall be arranged in such a way that a single failure to a deck or bulkhead shall not permit the entry of gas or fumes from the cargo tanks into any of the above spaces. The recess provided in accordance with 2.4.7 may be disregarded when determining the location of the said spaces.

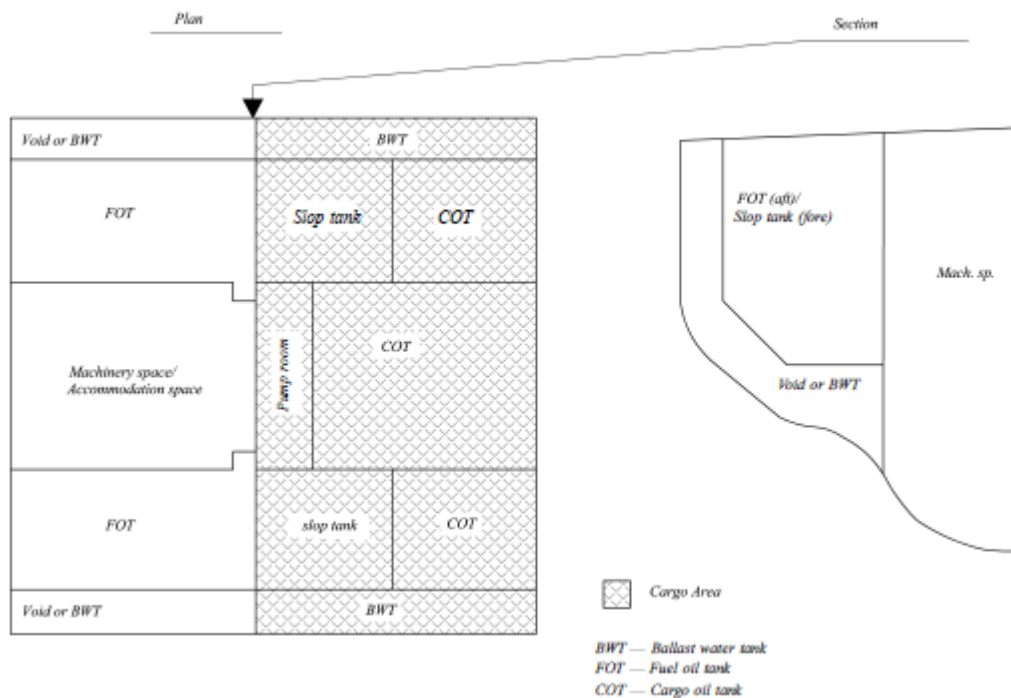

Fig. 2.4.7

Enclosed smoking rooms shall be provided within the accommodation area. These spaces shall be formed by "B-15" class divisions, and facings shall be made of materials having low flame spread characteristics.

**2.4.10** Where deemed necessary and on agreement with the Register, control stations, cargo control rooms, accommodation and service spaces may be positioned forward of the cargo tanks, slop tanks and spaces which isolate cargo tanks and slop tanks from machinery spaces but not necessarily forward of fuel oil tanks or ballast tanks. Machinery spaces other than category A may be permitted forward of the cargo tanks and slop tanks provided they are isolated from the cargo tanks and slop tanks by cofferdams, pump rooms, fuel oil tanks or ballast tanks.

All of the above-mentioned spaces shall be subject to an equivalent standard of safety and appropriate availability of fire extinguishing appliances. Control stations, cargo control rooms, accommodation and service spaces shall be arranged in such a way that a single failure of a deck or a bulkhead shall not permit the entry of gas or fumes from the cargo tanks into such spaces. In addition, where deemed necessary for the safety of navigation of the ship, machinery spaces containing internal combustion engines not being main propulsion machinery having output greater than 375 kW may be located forward of the cargo area.

Paint lockers, regardless of their use shall not be positioned above the tanks and spaces as determined in 2.4.9.

**2.4.11** No access holes to fuel oil tanks located in the double bottom below cargo tanks are permitted in cargo tanks and in the machinery space.

**2.4.12** Means shall be provided to keep deck spills away from the accommodation and service spaces.

This may be accomplished by provision of a permanent continuous coaming of a height at least 300 mm from side to side. Similar measures and arrangements shall be provided for stern loading.

**2.4.13** Manholes, openings for cleaning cargo tanks and other openings shall not be arranged in completely enclosed or in semi-enclosed spaces.

**2.4.14** The following requirements shall be also met in combination carriers:

**.1** the slop tanks shall be surrounded by cofferdams, except where the boundaries of the slop tanks are the hull, main cargo deck, cargo pump room bulkhead or fuel oil bunker tank. These cofferdams shall not be open to a double bottom, pipe tunnel, pump room or other enclosed space, as well as they shall not be used for carriage of cargo or ballast and they need not be connected with cargo or ballast systems.

Means shall be provided for filling the cofferdams with water and draining them.

Where the boundary of the slop tank is the cargo pump room bulkhead, the pump room shall not be open to the double bottom, pipe tunnel or other enclosed space. However, openings provided with gastight bolted covers may be permitted;

**.2** hatches and tank cleaning openings to slop tanks shall be only permitted on the open deck;

they shall be fitted with closing arrangements, except where they consist of bolted plates with bolts at watertight spacing. Closing arrangements shall be fitted with securing devices controlled by responsible person out of ship officers;

.3 arrangement of openings for cargo handling operations in decks and bulkheads separating the spaces for the carriage of oil and oil products from the spaces not intended or fitted for their carriage is permitted only provided equivalent tightness for oil products and their vapours is ensured;

.4 detailed instructions shall be exhibited on board, covering safety measures to be taken during loading or unloading of the ship and when dry cargoes are carried with oil product residues in the slop tanks.

**2.4.15** Where the electrochemical protection is fitted on the ship it shall comply with the following requirements:

.1 where the electrochemical protection of structures or their elements is fitted, anodes can be made of zinc, magnesium or aluminium alloys;

.2 impressed current systems are not permitted in oil cargo tanks either are permitted magnesium or magnesium alloy anodes in cargo tanks or tanks adjacent to cargo tanks;

.3 aluminium alloy anodes are only permitted in cargo tanks and tanks adjacent to cargo tanks of ships carrying oil products in locations where the potential energy does not exceed 275 J. The height of the anode shall be measured from the bottom of the tank to the centre of the anode, and its weight shall be taken as the weight of the anode as fitted, including the fitting devices and inserts.

However, where aluminium alloy anodes are located on horizontal surfaces such as bulkhead girders and stringers not less than 1 m wide and fitted with an upstanding flange or face flat projecting not less than 75 mm above the horizontal surface, the height of the anode may be measured from the surface.

Aluminium alloy anodes shall not be located under tank hatches or openings (in order to avoid any metal parts falling on the fitted anodes), unless protected by adjacent structure;

.4 the anodes shall have steel covers and these shall be sufficiently rigid to avoid resonance in the anode support and be designed so that they retain the anode even when it is wasted. Anodes shall be fitted with delimiters from sides and bottom made of the material which does not spark while contact with the anode. The steel inserts shall be attached to the structure by means of a continuous weld of adequate section, the weld elements shall be free of stress concentrations. Alternatively they may be attached to separate supports by bolting, provided a minimum of two bolts with locknuts are used.

However, other mechanical means of clamping approved by the Register may be accepted.

The supports at each end of an anode shall not be attached to separate items which are likely to move independently.

**2.4.16** The fenders shall be made of or securely faced with non-sparking materials, and shall not be bolted to the shell plating.

## 2.5 FISHING VESSELS

**2.5.1** The requirements of this Chapter are additional to those set out in **2.1** and apply to fishing vessels of 500 gross tonnage and upwards and/or 45 m and more in length, the definition of which is given in **1.2.1**, Part I "Classification" of the Rules for the Classification and Construction of Small Sea Fishing Vessels.

**2.5.2** In way of accommodation and service spaces and control stations one of three methods of protection shall be adopted in compliance with **2.3.2**.

**2.5.3** The minimum fire integrity of the bulkheads and decks separating adjacent spaces shall be as prescribed in Tables 2.5.3-1 and 2.5.3-2.

**Table 2.5.3-1 Fire integrity of bulkheads separating adjacent spaces**

Spaces	2	3	4	5	6	7	8	9	10	11	12
Control stations	1)	A-0 <sup>1</sup>	A-0	A-60	A-0	A-15	A-60	A-15	A-60	A-60	*
Corridors and lobbies	2)		C	B-0	B-0 A-0 <sup>2</sup>	B-0	A-60	A-0	A-0	A-0	*
Accommodation spaces	3)			C <sup>3,4</sup>	B-0 A-0 <sup>2</sup>	B-0	A-60	A-0	A-0	A-0	*
Stairways	4)				B-0 A-0 <sup>2</sup>	B-0 A-0 <sup>2</sup>	A-60	A-0	A-0	A-0	*
Service spaces (low risk)	5)					C	A-60	A-0	A-0	A-0	*
Machinery spaces of category A	6)						*	A-0	A-0 <sup>5</sup>	A-60	*
Other machinery spaces	7)							A-0 <sup>6</sup>	A-0	A-0	*
Cargo spaces	8)								*	A-0	*
Service spaces (high risk)	9)									A-0 <sup>6</sup>	*

Open decks	10)										*
------------	-----	--	--	--	--	--	--	--	--	--	---

Footnotes to Table 2.5.3-1

<sup>1</sup> Bulkheads separating the wheelhouse, chartroom and radio room from each other may be "B-0" class..

<sup>2</sup> For clarification as to which applies, refer to 2.1.4.3.

<sup>3</sup> Doors separating cabins from individual sanitary accommodation may be constructed of combustible materials in *method IC* fire protection. No special requirements are imposed upon bulkheads in *methods IIC* and *IIIC*.

<sup>4</sup> In case of *method IIIC* bulkheads of "B-0" class shall be provided between spaces or groups of spaces of 50 m<sup>2</sup> and over in area.

<sup>5</sup> "A-0" class may be used if no dangerous goods are intended to be carried. For cargo spaces intended for carriage of dangerous goods refer to 7.2.12.

<sup>6</sup> Where spaces are used for the same purpose, divisions between them need not be fitted.

**N o t e s :** 1 Where an asterisk appears in the tables the division shall be of steel or equivalent but is not required to be of "A" class. However, if in the deck except for the decks in a space of category (10), there are penetrations for electric cables, piping and ventilation ducts, such penetrations shall be flame and smoke tight. Divisions between control stations (emergency generators) and open decks may have air intake openings without closing appliances, except cases when fixed gas fire-fighting system is installed.

2 Refer to Note 4 to Table 2.2.1.3-1.

**Table 2.5.3-2 Fire integrity of decks separating adjacent spaces in ships**

Spaces	2	3	4	5	6	7	8	9	10	11	12
Control stations	1)	A-0	A-0	A-0	A-0	A-0	A-60	A-0	A-0	A-0	*
Corridors and lobbies	2)	A-0	*	*	A-0	*	A-60	A-0	A-0	A-0	*
Accommodation spaces	3)	A-60	A-0	*	A-0	*	A-60	A-0	A-0	A-0	*
Stairways	4)	A-0	A-0	A-0	*	A-0	A-60	A-0	A-0	A-0	*
Service spaces (low risk)	5)	A-15	A-0	A-0	A-0	*	A-60	A-0	A-0	A-0	*
Machinery spaces of category A	6)	A-60	A-60	A-60	A-60	A-60	*	A-60 <sup>1</sup>	A-30	A-60	*
Other machinery spaces	7)	A-15	A-0	A-0	A-0	A-0	A-0	*	A-0	A-0	*
Cargo spaces	8)	A-60	A-0	A-0	A-0	A-0	A-0	A-0	*	A-0	*
Service spaces (high risk)	9)	A-60	A-0	A-0	A-0	A-0	A-60	A-0	A-0	A-0 <sup>2</sup>	*
Open decks	10)	*	*	*	*	*	*	*	*	*	-

Footnotes to Table 2.5.3-2.

<sup>1</sup> Where other machinery spaces of category (7) are the spaces of low fire risk, i.e. they do not contain machinery operating on fuel oil or having a pressure lubrication systems, "A-0" class divisions are permitted.

<sup>2</sup> Refer to Footnote 6 to Table 2.5.3-1.

**N o t e s :** 1. Refer to Note 1 to Table 2.5.3-1.

2. Refer to Note 4 to Table 2.2.1.3-1.

For determining the appropriate fire integrity standards to be applied to divisions between adjacent spaces, the spaces are classified according to their fire risk as follows:

(1) control stations: spaces accommodating emergency sources of electrical power and lighting; wheelhouse and navigation room;

spaces accommodating ship radio equipment;

fire stations; main machinery control room if it is located outside machinery space;

spaces accommodating centralized fire alarm system;

(2) corridors and lobbies;

(3) accommodation spaces in accordance with 1.5.2, except corridors;

(4) stairways:

interior stairways, lifts, totally enclosed emergency escape trunks and escalators (other than those wholly contained within the machinery spaces) and enclosures.

A stairway which is enclosed only at one level shall be regarded as part of the space from which it is not separated by a fire door;

(5) service spaces (low risk):

storerooms not having provisions for the storage of flammable liquids and having areas less than 4 m<sup>2</sup>; drying rooms and laundries;

refrigerated provision storerooms insulated with non-combustible materials;

spaces accommodating electrical distribution boards having an area of less than 4 m<sup>2</sup>;

(6) machinery spaces of category A:

spaces as defined in 1.2, Part VII "Machinery Installations";

incinerator rooms and combined incinerator/waste stowage spaces and the flue uptakes from such spaces (refer to 2.1.5.9);

(7) other machinery spaces:

machinery spaces excluding those specified in (6);

spaces for fish meal plants;

spaces accommodating electrical equipment (automatic telephone stations, spaces for air conditioning ducts);

(8) cargo spaces:

all spaces used for carriage of cargoes (including bulk cargo tanks) as well as trunkways and hatchways to such spaces;

(9) service spaces (greater fire risk): galleys and pantries containing appliances for hot food preparation, saunas;

storerooms with an area of 4 m<sup>2</sup> and over;

paint lockers and lamp lockers;

spaces for storage of flammable liquids;

workshops and similar spaces, which are not part of machinery spaces;

waste stowage spaces and garbage chutes connected thereto;

(10) open decks:

open deck spaces and enclosed rest areas having no fire risk (this means that their furnishings shall be restricted to deck furniture; in addition, such spaces shall be naturally ventilated by permanent openings:

raw fish-filleting areas, fish washing rooms and similar spaces with no fire risk;

air spaces (spaces outside superstructures and deckhouses).

**2.5.4** Linings, ceilings, draught stops and their associated grounds shall be made of non-combustible materials:

in accommodation and service spaces, and in control stations, if protection *method IC* is used;

in corridors and stairway enclosures serving accommodation and service spaces, and control stations, if protection *methods IIC* and *IIIC* are used.

**2.5.5** Provisions of **2.3.5** shall apply to bulkheads within accommodation and service spaces not required to be "A" or "B" class divisions.

Within accommodation spaces, bulkheads required to be "B" class divisions shall extend from deck to deck and to the shell or other boundaries. However, if the continuous "B" class ceilings or linings are fitted on both sides of the bulkhead, the bulkhead may terminate at the continuous ceiling or lining.

**2.5.6** Provisions of **2.3.5.3**, **2.3.6**, **2.3.7** and **2.3.8** shall apply to fire doors.

**2.5.7** For the purpose of application of the requirements of **2.1.1.7**, **2.1.1.8** and **2.1.1.10** it is necessary to follow Fig. 2.3.10 and Table 2.3.10 subgroup 1 for the *method IC*, subgroup 2 for the *methods IIC* and *IIIC*.

**2.5.8** As a lining material for specially equipped fish-processing shops (for raw fish filleting and washing, refrigerating, canning shops) moisture-resistant plywood with low flame-spread characteristics may be used as specified in the FTP Code 2010. For plastic laminated moisture-resistant plywood, both composing materials (plywood and laminate) shall have low flame-spread characteristics.

## **2.6 FISHING VESSELS OF LESS THAN 500 GROSS TONNAGE**

**2.6.1** Unless otherwise stated, the requirements of this Chapter are additional to those set out in **2.1** and apply to fishing vessels of less than 500 gross tonnage and 24 m in length and over but less than 45 m, the definition of which is given in 1.2.1, Part I "Classification" of the Rules for the Classification and Construction of Small Sea Fishing Vessels.

**2.6.2** In way of accommodation and service spaces and control stations *method IC* fire protection shall be adopted in compliance with **2.3.2**.

**2.6.3** The minimum fire integrity of the bulkheads and decks separating adjacent spaces shall be as prescribed in Tables 2.6.3-1 and 2.6.3-2.

For determining the appropriate fire integrity standards to be applied to divisions between adjacent spaces, the spaces are classified according to their fire risk according to **2.5.3**.

**2.6.4** In accommodation and service spaces, in control stations as well as in corridors and stairway enclosures serving accommodation and service spaces and control stations, linings, ceilings, draught stops and their associated grounds shall be made of non-combustible materials.

**2.6.5** Within accommodation spaces, bulkheads required to be "B" class divisions shall extend from deck to deck and to the shell or other boundaries. However, if the continuous "B" class ceilings or linings are fitted on both sides of the bulkhead, the bulkhead may terminate at the continuous ceiling or lining.

Within accommodation spaces, bulkheads not required to be "A" or "B" class divisions, shall be at least "C" class division.

Application of combustible materials may be allowed for doors separating cabins from internal sanitary spaces.

### **Table 2.6.3-1 Fire integrity of bulkheads separating adjacent spaces**



Spaces	2	3	4	5	6	7	8	9	10	11	12
Control stations	1)	A-0 <sup>1</sup>	A-0	A-60	A-0	A-15	A-60	A-15	A-60	A-60	*
Corridors and lobbies	2)		C	B-0	B-0	B-0	A-60	A-0	A-0	A-0 <sup>2</sup> B-15	*
Accommodation spaces	3)			C <sup>3</sup>	B-0	B-0	A-60	A-0	A-0	A-0 <sup>2</sup> B-15	*
Stairways	4)				B-0	B-0	A-60	A-0	A-0	A-0 <sup>2</sup> B-15	*
Service spaces (low risk)	5)					C	A-60	A-0	A-0	A-0 <sup>2</sup> B-15	*
Machinery spaces of category A	6)						*	A-0	A-0 <sup>4</sup>	A-60	*
Other machinery spaces	7)							A-0 <sup>5</sup>	A-0	A-0	*
Cargo spaces	8)								*	A-0	*
Service spaces (high risk)	9)									A-0 <sup>2,5</sup> B-15 <sup>5</sup>	*
Open decks	10)										-

Footnotes to Table 2.6.3-1

<sup>1</sup>Bulkheads separating the wheelhouse, chartroom and radio room from each other may be of "B-0" class.

<sup>2</sup>Bulkheads separating galley from spaces of categories (2) — (5) and (9), shall be of "A-0" class. Bulkheads separating storerooms for flammable materials and substances from spaces of categories (2), (4), (5) and (9), shall be of "A-0" class (storerooms shall not be adjacent to accommodation spaces).

<sup>3</sup>Doors separating cabins from individual sanitary accommodation may be constructed of combustible materials.

<sup>4</sup>"A-0" class may be used if no dangerous goods, for example, fish meal, are intended to be carried. For cargo spaces intended for carriage of dangerous goods refer to 7.2.12.

<sup>5</sup>Where spaces are used for the same purpose, divisions between them need not be fitted.

Notes: 1. When an asterisk appears in the tables, the division shall be of steel or equivalent material, but is not required to be of "A" class. However, if in the deck except for the decks in a space of category (10), there are penetrations for electric cables, piping and ventilation ducts, such penetrations shall be flame and smoke tight. Divisions between control stations (emergency generators) and open decks may have air intake openings without closing appliances, except cases when fixed gas fire-fighting system is installed.

2. Refer to Note 4 to Table 2.2.1.3-1.

Table 2.6.3-2 Fire integrity of decks separating adjacent spaces in ships

Spaces	2	3	4	5	6	7	8	9	10	11	12
Control stations	1)	A-0	A-0	A-0	A-0	A-0	A-60	A-0	A-0	A-0	*
Corridors and lobbies	2)	A-0	*	*	A-0	*	A-60	A-0	A-0	A-0	*
Accommodation spaces	3)	A-60	A-0	*	A-0	*	A-60	A-0	A-0	A-0	*
Stairways	4)	A-0	A-0	A-0	*	A-0	A-60	A-0	A-0	A-0	*
Service spaces (low risk)	5)	A-15	A-0	A-0	A-0	*	A-60	A-0	A-0	A-0	*
Machinery spaces of category A	6)	A-60	A-60	A-60	A-60	A-60	*	A-60 <sup>1</sup>	A-30	A-60	*
Other machinery spaces	7)	A-15	A-0	A-0	A-0	A-0	A-0	*	A-0	A-0	*
Cargo spaces	8)	A-60	A-0	A-0	A-0	A-0	A-0	A-0	*	A-0	*
Service spaces (high risk)	9)	A-60	A-0	A-0	A-0	A-0	A-60	A-0	A-0	A-0 <sup>2</sup>	*
Open decks	10)	*	*	*	*	*	*	*	*	*	-

Footnotes to Table 2.5.3-2.

<sup>1</sup> Where other machinery spaces of category (7) are the spaces of low fire risk, i.e. they do not contain machinery operating on fuel oil or having a pressure lubrication systems, "A-0" class divisions are permitted.

<sup>2</sup> Refer to Footnote 6 to Table 2.5.3-1.

Notes: 1. Refer to Note 1 to Table 2.6.3-1.

2. Refer to Note 4 to Table 2.2.1.3-1.

**2.6.6** In accommodation spaces, service spaces and control stations where stairways penetrate more than a single deck, shall be surrounded by "B-0" class divisions with self-closing doors at all levels.

Stairways, which penetrate only a single deck, shall be protected at least at one level by at least "B-0" class divisions and self-closing doors. Lift trunks shall be constructed of steel or equivalent material and shall be so fitted as to prevent the passage of smoke and flame from one 'tween-deck space to another and shall be provided with means of closing so as to permit the control of draught and smoke.

**2.6.7** Air spaces enclosed behind ceilings, panellings, or linings shall be divided by close fitting draught stops spaced not more than 7 m apart. In the vertical direction, such air spaces, including those behind linings of stairways, trunks, etc., shall be closed at each deck.

**2.6.8** Provisions of 2.3.6, 2.3.7 and 2.3.8 shall apply to fire doors.

**2.6.9** For the purpose of application of the requirements given in **2.1.1.7**, **2.1.1.8** and **2.1.1.10** it is necessary to use Fig. 2.3.10 and Table 2.3.10-1.

**2.6.10** As a lining material for specially equipped fish-processing shops (for raw fish filleting and washing, refrigerating, canning shops) moisture-resistant plywood with low flame spread characteristics may be used as specified in the FTP Code. For plastic laminated moisture-resistant plywood, both composing materials (plywood and laminate) shall have low flame-spread characteristics.

### **3 FIRE-FIGHTING EQUIPMENT AND SYSTEMS**

#### **3.1 GENERAL**

##### **3.1.1 General.**

**3.1.1.1** The requirements of this Section are applicable to all fire-fighting equipment and systems fitted in sea-going ships for the purpose of fire protection of the ship concerned.

Where provision is made in a ship for extra fire extinguishing systems in addition to those prescribed by this Section, such systems shall also comply with the requirements set out below, to an extent approved by the Register.

During design and manufacture of fire extinguishing systems, the requirements of the FSS Code and Sections **1**, **2**, **4**, **5**, Part VIII "Systems and Piping" of these Rules shall be complied with.

**3.1.1.2** Fire-fighting equipment and systems shall be so constructed that they will be efficient and readily available for operation under all service conditions (refer to **2.3.1**, Part VII "Machinery Installations").

**3.1.1.3** Containers and pressure vessels used in fire extinguishing systems shall meet the requirements set forth in **6.4**, Part X "Boilers, Heat Exchangers and Pressure Vessels".

**3.1.1.4** The use of a fire extinguishing medium which either by itself or under expected conditions of use gives off toxic gases in such quantities as to endanger the persons shall not be permitted. It is prohibited to install in ships new fire extinguishing plants utilizing halon 1211, halon 1301 и halon 2402, as well as perfluoridecarbons.

##### **3.1.2 Fire extinguishing systems.**

**3.1.2.1** In addition to the water fire main system and in accordance with the purpose for which they are intended, all ship's spaces shall be protected by one of the fixed fire extinguishing systems according to Table 3.1.2.1, unless expressly provided otherwise.

The Register may consider the use of other equivalent systems, ensuring equivalent protection.

For machinery spaces of category A and pump rooms specified in 1.5.7.1, equivalent fire extinguishing systems complying with the requirements of 3.13 may be used instead of pressure water-spraying systems and carbon dioxide smothering systems.

Instead of a pressure water-spraying system a water screen fire extinguishing system approved on the basis of circulars MSC / Circ 1165, MSC.1 / Circ. 1269, MSC.1 / Circ. 1385, MSC.1 / Circ. 1386 may be installed.

For protection of spaces specified in **1.5.4.3**, **1.5.4.4** and **1.5.9**, the Register may permit the use of fixed fire extinguishing system other than prescribed by Table 3.1.2.1, if the full-scale test in conditions simulating spilled petroleum burning in the said space will prove that alternative system is not less effective in fire fighting (refer to IMO circular MSC/Circ.914).

**3.1.2.2** Calculation of the necessary quantity of the fire-extinguishing medium shall be made for each protected space. The maximum calculation values shall be taken for the quantity of stored fire extinguishing medium.

Fire extinguishing system shall be fitted with valves normally closed for transfer of fire extinguishing medium to the appropriate space.

Where two or more adjacent spaces presenting different degrees of fire risk are not separated by gastight or watertight bulkheads or decks, or where fuel oil can flow from one space into another and the possibility of such flowing is not eliminated structurally, the choice of fire extinguishing medium and, consequently, of a fire extinguishing system shall be made to comply with the requirements for the fire protection of the space which affords the greatest fire risk, and the calculation of the necessary quantity of fire extinguishing medium and the rate of application shall be made on the basis of the total area or volume, respectively, of all spaces thus communicating.

When calculating the necessary quantity of the fire extinguishing medium and its application rate for fixed gas fire extinguishing systems, the adjacent spaces with independent ventilation systems not separated by at least "A-0" class divisions shall be considered as the same space.

**Table 3.1.2.1**

		Fixed fire extinguishing systems
--	--	----------------------------------

Nos.	Description of spaces	Sprinkler	Pressure water spraying	Waterscreen	Drenching	Foam fire extinguishing	Carbon dioxide smothering	Dry powder	Aerosol	Inert gas
1	2	3	4	5	6	7	8	9	10	11
1	Control stations listed in 1.5.1.1, 1.5.1.5	+ <sup>1</sup>	+							
2	Control stations listed in 1.5.1.2 <sup>2</sup>		+			+	+		+	
3	Accommodation spaces listed in 1.5.2.1 and 1.5.2.2	+ <sup>1</sup>								
4	Service spaces listed in 1.5.3.1, 1.5.3.2.3 and 1.5.3.2.4	+ <sup>1</sup>								
5	Storerooms listed in 1.5.3.2.1				+					
6	Storerooms listed in 1.5.3.2.2.3	+ <sup>1</sup>	+		+ <sup>4</sup>	+	+	+ <sup>5</sup>		
7	Cargo spaces listed in 1.5.4.3, 1.5.4.4		+	+ <sup>6</sup>		+ <sup>7</sup>	+ <sup>8</sup>			+ <sup>8</sup>
8	Tanks for petroleum products, refer to 1.5.4.1					+				
9	Cargo spaces, refer to 1.5.4.2 <sup>9,10</sup>		+ <sup>11,12</sup>			+ <sup>4</sup>	+ <sup>13</sup>			+
10	Machinery spaces of category A <sup>2,14</sup> , hangers and spaces where refuelling and hanger facilities are located; spaces containing equipment for the fuel preparation specified in 6.8.2.5		+			+ <sup>7</sup>	+		+	
11	Silencers of internal combustion engines <sup>15</sup> , regenerators of gas turbine installation <sup>16</sup> and exhaust ducts from galley ranges <sup>17</sup> , exhaust gas boilers		+				+			
12	Unattended machinery spaces containing propulsion electric motors, steam engines or steam turbines having power output not less than 375 kW		+ <sup>18</sup>			+ <sup>7</sup>	+		+	
13	Pump rooms listed in 1.5.7.1		+			+ <sup>7</sup>	+ <sup>19</sup>		+ <sup>5</sup>	
14	Working spaces listed in 1.5.8.1		+			+ <sup>7</sup>	+		+	
15	Fire zones of category A machinery spaces				+ <sup>20</sup>					
16	Special category spaces listed in 1.5.9		+							
17	Cargo tank deck in gas carriers and cargo piping and cargo manifolds							+		
18	Rooms for separators, etc. and other spaces specified in 4.2.7, Part VII "Machinery Installations"		+			+ <sup>7</sup>	+		+	
19	Scavenge spaces of the crosshead type internal combustion engines (refer to 2.2.4, Part IX "Machinery")						+			
20	Area of forward and aft loading/unloading arrangements in oil tankers, helidecks					+				
21	Chain stoppers and cargo hose connections on oil tankers accommodated to mooring at point berths carried out to sea and fitted up with a forward cargo gear		+							
22	Corridors and stairways	+ <sup>21</sup>								
23	Incinerator room refer to 1.5.9					+	+			
24	Waste storage room, combined room for incinerators and waste storage refer to 1.5.9	+								
25	Special electrical room refer to 1.5.10 <sup>22</sup>						+	+ <sup>23</sup>		

<sup>1</sup>Automatic sprinkler system shall be installed:

In passenger ships carrying more than 36 passengers in control stations, accommodation and service spaces including corridors and stairways. Alternatively, control stations, where water may damage essential equipment may be fitted with an approved fixed fire extinguishing system of another type (refer to 3.3.1.1). The system may not be fitted in spaces of minor or no fire risk as void spaces, public toilets, carbon dioxide cylinder rooms and similar spaces;

in passenger ships carrying not more than 36 passengers (where fixed smoke detection alarm system is fitted only in corridors, stairways and escape routes within accommodation spaces) in accommodation and service spaces and if the Register deems it necessary, in control stations (refer to 1.5.1.2), except in spaces of minor or no fire risk as void spaces, sanitary rooms, etc;

- in cargo ships where *method IIC* is adopted in accommodation spaces, galleys and other service spaces, except spaces of minor or no fire risk as void spaces, sanitary rooms, etc;
- incinerator and combined incinerator/ waste storage spaces, and the flue uptakes from such spaces (refer to **2.1.5.9**).
- <sup>2</sup>Where the capacity of emergency diesel-generator is lower than 375 kW, the control station space may be protected by portable fire extinguishers according to Table 5.1.2.
- <sup>3</sup>Paint lockers and storerooms for flammable liquids, liquefied and compressed gases need not be fitted with a fixed fire extinguishing system, if the area of each storage space is not more than 4 m<sup>2</sup> (refer to **3.1.3.4**). Spaces for storage of cargo specimen located in the tanker cargo area may not be fitted with fire extinguishing system.
- <sup>4</sup>A system using medium expansion foam with expansion ratio of about 100:1 shall be used, except for the hangars for helicopters and enclosed garages where a system with foam expansion ratio about 1000:1 shall be employed.
- <sup>5</sup>Explosion-proof aerosol generators shall be installed.
- <sup>6</sup>Water screens are used in addition to the systems specified in cols 4, 7 and 10 in cases indicated in **2.2.1.2**.
- <sup>7</sup>A system using foam with expansion ratio of about 1000:1 shall be used, provided that foam concentrate is applicable for fire extinction of the cargoes carried.
- <sup>8</sup>A carbon dioxide smothering system may be installed only in the cargo spaces, which may be closed tightly from a location outside the said spaces. Refer also to **3.1.2.13**.
- <sup>9</sup>A foam fire extinguishing system shall not be used for the protection of cargo spaces of container ships.
- <sup>10</sup>On agreement with the Register spaces for general cargoes except dangerous goods may not be fitted with fixed fire extinguishing systems in the following cases:
- in passenger ships engaged in short voyages;
  - in passenger ships of less than 1000 gross tonnage, provided the ship is fitted with portable fire-fighting equipment for cargo spaces, as well as with steel hatch covers and effective closing appliances of all ventilating and other openings leading to cargo spaces;
  - in cargo ships of less than 2000 gross tonnage constructed or intended only for the carriage of ore, coal, grain, green timber, non-combustible cargoes and cargoes of minor fire risk (refer to Table 1 of IMO circular MSC.1/Circ.1395), provided the ship is fitted with steel hatch covers and effective closing appliances of all ventilating and other openings leading to cargo spaces;
  - in cargo spaces are carried only such cargoes, for which fixed gas fire extinguishing system is not efficient (refer to Table 2 of IMO circular MSC.1/Circ.1395/Rev.2), provided the requirement of **7.2.5.2** is fulfilled.
- <sup>11</sup>In fish meal cargo spaces the rate of water discharge shall be 1,5 l/min per 1 m<sup>2</sup>; in combined cargo spaces for fish meal and intended also for carriage and storage of packages the rate of water discharge shall be 5 l/min per 1 m<sup>2</sup>.
- <sup>12</sup>Spaces for the carriage of Class 1 dangerous goods, except 1.4S, in addition to the smothering system shall be protected according to 7.2.5.3. Refer also to the International Convention on Load Lines, 1966 (LL 66), as modified by the Protocol of 1988 relating thereto with further amendments (LL 66/88)
- <sup>13</sup>A carbon dioxide smothering system or any equivalent fire extinguishing system may not be installed in fishing vessels for protection of the refrigerated cargo holds provided they are not cargo spaces of high fire risk and/or not intended for storage and carriage of packages.
- <sup>14</sup>Where an auxiliary oil-fired boiler or boilers as well as incinerators operating on fuel oil situated inside the machinery space is (are) not isolated from the rest of the space by gastight enclosure bulkheads and platforms, the machinery space shall be fitted with one of the above fire extinguishing systems, this system being capable of protecting the entire space, even where this machinery space does not contain any other oil-fired equipment or machinery, besides the above boilers.
- <sup>15</sup>The silencers of medium- and high-speed engines need not to be fitted with the fixed fire extinguishing system, when there are spark arresters in the exhausts. This requirement does not apply to fishing vessels of less than 500 gross tonnage.
- <sup>16</sup>Installation of one of the above systems is compulsory for all ships carrying flammable liquids and ships that serve them, all ships carrying readily flammable dry cargoes, irrespective of their gross tonnage, and for all other ships with a total power of main and auxiliary machinery more than 740 kW.
- <sup>17</sup>In passenger ships carrying not more than 36 passengers and in cargo ships is required when ducts pass through some spaces located in way of accommodation spaces.
- <sup>18</sup>Pressure water-spraying system may be used only for spaces where steam turbines or steam engines are of enclosed type.
- <sup>19</sup>A warning notice shall be provided at the carbon dioxide smothering system controls stating that because of ignition hazard caused by electrostatic discharges the system shall be used only for fire extinguishing but not for inerting purposes.
- <sup>20</sup>Refer to **3.12**.
- <sup>21</sup>The sprinkler system is compulsory only on passenger ships carrying more than 36 passengers.
- <sup>22</sup>Special electrical rooms with a deck area of 4m<sup>2</sup> and over.
- <sup>23</sup>Use of powder extinguishing system is allowed in all rooms, except rooms in which the electric - or radio equipment under voltage over 1000 volts is located.

**3.1.2.3** Where a fixed gas fire extinguishing system is used, the openings through which air may penetrate to or gas may escape from a protected space shall be capable of being closed from outside the protected space. Watertight and gastight doors in the bulkhead separating adjacent machinery spaces may be considered as closures of openings in such bulkhead only where they are of a self-closing type or operated remotely and the fire extinction stations, from which the extinguishing medium may be discharged, are provided with the signalling of the fully closed doors. In the absence of such signalling, the calculation of the required amount and the rate of discharge of extinguishing medium shall be based on the requirement of providing for the total volume (area) of the adjacent spaces.

**3.1.2.4** In multi-deck ships, one 'tween deck is considered as separated from another 'tween deck or hold by a gastight deck, provided the cargo hatchways, other hatchways and openings in this deck are closed with watertight or gastight steel hatch closures and covers, while watertight stops are fitted where the deck is pierced in way of the framing. In the absence of such closures and stops, the spaces shall be considered as communicating, and the extinguishing medium calculation shall be made on the basis of the total volume of the spaces.

**3.1.2.5** Where a space protected by means of carbon dioxide smothering system and aerosol fire extinguishing system contains air reservoirs the required quantity of extinguishing medium shall be calculated on the basis of the designed volume of the protected space plus the excess of the free volume of

the compressed air. If arrangements are made for discharging the compressed air outside the protected space, by means of relief valves and fuses provided on the air reservoirs then an increase of the quantity of carbon dioxide in the carbon dioxide smothering systems need not be provided and the volume of the air in the air receivers in the aerosol fire extinguishing systems while assessment of the quantity of the aerosol generating compound may be not considered (refer to 3.11.1.3).

**3.1.2.6** In order to prevent excessive pressure in spaces protected by fire smothering systems, due to discharge of extinguishing medium, such spaces shall be fitted with breather valves, where necessary, or other available means (e.g. air pipes or ventilation ducts) shall be used.

**3.1.2.7** Spaces for fuel oil units (refer to item 18 of Table 3.1.2.1) enclosed inside engine rooms may have either an independent fire extinguishing system or they may be protected by the fire extinguishing system of the engine room.

**3.1.2.8** Whatever a fixed fire extinguishing system is specified in Table 3.1.2.1 for boiler spaces of oil tankers in which crude oil or clops are used for boilers, provision shall be made for 135 l capacity foam extinguisher in compliance with 5.1.10 or an equivalent foam unit both equipped with fixed foam generators capable of delivering foam to the boiler fronts and to trap under burners, valves and connections. This fire extinguisher (unit) shall be remote operated from outside the boiler room.

**3.1.2.9** The systems shall be so arranged as to provide the delivery of extinguishing medium to the entire space protected, including the enclosed portions thereof (e.g. control stations, workshops, etc. in machinery spaces).

**3.1.2.10** The use of steam may be permitted by the Register depending on the particular case as an addition to the required fire extinguishing medium; the boiler or boilers available for supplying steam shall have an evaporation of at least 1,0 kg of steam per hour for each 0,75 m<sup>3</sup> of the gross volume of the largest space so protected.

**3.1.2.11** Where gas, which is a gaseous product of oil fuel combustion, is used as a fire extinguishing medium, the systems using it for protection of machinery and cargo spaces shall comply with the FSS Code.

**3.1.2.12** Liquid cargoes with the flash point above 60°C other than oil products or liquid cargoes liable to the requirements of the IBC Code are treated as those with low fire risk and requiring no fixed foam fire extinguishing system.

**3.1.2.13** For protection of cargo spaces fitted with partially weathertight hatchway covers on board containerships (refer to IMO circular MSC/Circ.1087), the requirements of Section 2 of the above circular shall serve as a guide when calculating the amount of carbon dioxide in the carbon dioxide fire extinguishing systems. If the clear gaps between hatchway covers exceed 50 mm, fixed pressure water-spraying system shall be fitted in the cargo spaces.

**3.1.2.14** Deep-fat cooking equipment, installed in enclosed spaces or on open decks, shall be fitted with an automatic or manual fire extinguishing system tested according to the international standard ISO 15371 "Fire Extinguishing Systems for Protection of Galley Deep-Fat Cooking Equipment". Controls for manual operation of the fire extinguishing system shall be clearly labeled. When actuating this system the following shall be provided:

.1 automatic shutdown of electrical power supply to the deep-fat cooking equipment;

.2 the alarms giving warning of actuation of this system in a galley where deep fat cooking equipment is fitted.

Deep-fat cooking equipment shall be equipped with main and auxiliary thermostats with individual failure warning systems.

**3.1.2.15** All doors to spaces protected by volumetric fire extinguishing systems shall be marked as follows:

**"The room is protected by a volumetric fire extinguishing / aerosol fire extinguishing system and must be left after system's activation alarm."**

### **3.1.3 Arrangement and equipment of fire extinction stations.**

**3.1.3.1** Mechanical equipment, such as foam mixers, reservoirs, cylinders or vessels containing extinguishing medium or compressed air, inert gas generators, or high expansion foam generators, refrigerating plants, etc., as well as the starting controls of all fire extinguishing systems, except for the water fire main system, shall be arranged as a rule in fire extinction stations outside the protected spaces (refer also to 3.1.3.5). Spaces for storage of fire extinguishing medium located below deck or having no access from the open deck shall be provided with mechanical ventilation system in compliance with 12.9.1, Part VIII "Systems and Piping".

The storage rooms for fixed gas fire extinguishing systems of fire extinction stations shall be used for no other purpose.

Pumps, other than those servicing the fire main, required for the water supply to fire extinguishing systems, their sources of power and controls shall be fitted outside the space or spaces protected by such systems and shall be so arranged as to prevent failure of any system in case of fire in the space or spaces protected.

**3.1.3.2** Fire extinction stations shall comply with the following requirements:

**.1** any entrance to the fire extinction stations shall be, as a rule, from the open deck and shall be independent of the protected space. If the station is located below deck, it shall be located no more than one deck below the open deck and shall be directly accessible by a stairway or ladder from the open deck.

The means of controlling the fixed fire extinguishing system shall be readily accessible and shall be grouped in as few locations as possible at positions not likely to be cut off by a fire in the protected space;

**.2** stations shall not be arranged forward of the collision bulkhead;

**.3** bulkheads and decks (including doors and other means of closing any opening therein), which form the boundaries between them and adjacent enclosed spaces shall be gastight. Such storage rooms for fire extinguishing medium shall be considered as fire control stations when applying fire integrity tables;

**.4** the spaces housing stations shall be protected by heat insulation and shall be fitted with heating, if it is essential for normal operation of the station that positive temperature is maintained therein. The temperature in the spaces housing carbon dioxide extinction stations shall not exceed 45°C;

**.5** air temperature in the station shall be controlled by means of thermometer so fitted therein that its readings are visible both from inside the station and, through a scuttle, from outside the station; in case of remote control of temperature limit the scuttle need not be required;

**.6** fire extinction stations for cargo spaces shall be provided with telephone or other means of communication with the central control station and with the machinery space, if operation of the fire extinction station is dependent on the equipment located in the machinery space;

**.7** entrance doors shall be opened outwards and kept permanently locked and one set of keys for the locks shall be kept in a closed case with a glazed door located near the lock;

**.8** all valves and other arrangements of the station shall be provided with nameplates identifying them with the spaces whose protection is controlled by the individual valves or arrangements. In addition, a schematic plan of the fire extinguishing system showing the starting controls and the spaces protected, as well as brief instructions for starting and operating the system shall be displayed in a conspicuous position within the station.

**.9** stations located below the deck or rooms without direct access to weather deck shall be fitted with mechanical ventilation system providing air intake in the lower part of the room and a 6-fold air exchange per hour.

**3.1.3.3** For lockers of a deck area of less than 4 m<sup>2</sup>, containing combustible materials and substances (refer to **1.5.3.2.2**) which do not give access to accommodation spaces carbon dioxide portable fire extinguisher providing a minimum volume of free gas to 40 % of the gross space volume, may be accepted in lieu of fixed fire extinguishing systems. The inlet port shall be arranged in a locker bulkhead to allow discharge of extinguishing medium without entry into the protected space. This portable fire extinguisher shall be stowed adjacent to the port. Alternatively, a port or hose connection may be provided to facilitate the use of fire main water.

Alternatively, a hole may be used with a fire hose attached to it to supply water from the fire line.

**.1** Painting store rooms on passenger ships shall be protected as follows:

**.1.1** with a carbon dioxide fire extinguishing system designed to fill 40% grossvolume of the protected space;

**.1.2** with a powder extinguishing system designed to supply extinguishing powder not less than 0.5 kg/m;

**.1.3** with water spaying or sprinkler system designed to supply at least 5 l/min. per 1m<sup>2</sup>. The water spraying system shall be connected to the fire main; or.

**.1.4** with a system which, in the opinion of the Register, provides equivalent protection.

In any case, the system shall be activated from a station located outside the protected space.

**3.1.3.4** In passenger ships controls for any required fire extinguishing system for machinery spaces and the controls specified in **2.1.4.1**, **2.1.4.2.3**, as well as in **12.2.6** or **12.2.8** and **13.1.3**, Part VIII "Systems and Piping" shall be located together or shall be grouped in as few places as possible. A safe access to these places from the open deck shall be provided.

**3.1.3.5** In equivalent fixed gas fire extinguishing systems with modular configuration the fire extinguishing medium containers may be located in the protected space subject to the requirements of para 5 of Annex to IMO MSC.1/Circ.1267. The arrangement of fire extinguishing medium containers, the electrical

circuits and piping essential for the release of any system shall be such that in the event of damage to any one power release line or container valve through mechanical damage, fire or explosion in a protected space, and other equipment shall be so arranged as to provide the delivery of extinguishing medium quantity and its distribution, adequate to the minimum fire extinguishing concentration. However, NOAEL (no-observed-adverse-effect level) values calculated at the highest expected engine room temperature shall not be exceeded when discharging the total amount of extinguishing gas simultaneously.

Systems that can not comply with the above, for instance systems using only one bottle located inside the protected space, can not be accepted. Such systems shall be designed with the bottle(s) located outside the protected space, in a dedicated room in compliance with **3.1.3.2**.

**3.1.3.6** Fire extinguishing medium protecting the cargo holds may be stored in a room located forward the cargo holds, but aft of the collision bulkhead, provided that both the local manual release mechanism and remote control(s) for the release of the media are fitted, and the latter is of robust construction or so protected as to remain operable in case of fire in the protected spaces.

The remote controls shall be placed in the accommodation area in order to facilitate their ready accessibility by the crew.

The capability to release different quantities of fire extinguishing medium into different cargo holds so protected shall be included in the remote release arrangement.

#### **3.1.4 Pipes and fittings.**

**3.1.4.1** Pipes shall be so laid as to comply with the following requirements:

**.1** the necessary pipes for conveying fire extinguishing medium into the protected spaces shall be provided with control valves so marked as to indicate clearly the spaces to which the pipes are led.

Suitable provisions shall be made to prevent inadvertent release of the medium into the space.

This requirement does not apply to the foam extinguishing systems intended to deliver foam from outside the cargo tanks by means of monitors and portable air-foam nozzles or foam generators producing average expansion foam;

**.2** where a cargo space fitted with a gas fire extinguishing system is used as a passenger space, the gas connection shall be blanked during such use;

**.3** laying the pipes of fire extinguishing systems through spaces containing fuel oil and lubricating oil shall not be permitted.

Pipes of fire extinguishing systems, shall not be laid through refrigerated spaces;

**.4** gas fire extinguishing systems may pass through accommodation spaces, provided they have sufficient wall thickness, and their gas tightness after installation on board a ship is tested by test pressure of not less, than 5 N/mm<sup>2</sup>. Besides, pipelines running through the accommodation spaces shall be connected by welding only and shall not have condensate drainage openings or other openings within such spaces;

**.5** all fire extinguishing systems shall be so designed as to permit periodical checks in operation.

Systems fitted with pipes and nozzles for supply of fire extinguishing medium shall have arrangements for checking them in operation using compressed air.

A non-return shut-off valve shall be fitted on the pipeline supplying compressed air to the manifold of the fire smothering station;

**.6** gaskets and flexible joints used in fire extinguishing systems shall be made of non-combustible materials resistant to the effect of the extinguishing medium, and marine environment;

**.7** in piping sections where valve arrangements introduce sections of closed piping, such sections shall be fitted with a pressure relief valve and the outlet of the valve shall be led to open deck.

**3.1.4.2** Pipes shall be made of steel.

Copper, copper-and-nickel or bimetallic pipes (one of the layers being steel or copper) may be used as equivalent to steel pipes.

Carbon steel pipes shall have anti-corrosive coating both inside and outside.

The fittings of fire extinguishing systems, including sprinklers and sprayers, shall be made of materials resistant to the fire extinguishing medium and to marine environment. Nozzles of fixed pressure water-spraying and equivalent water-based fire extinguishing systems (fixed water-mist fire extinguishing systems) for machinery spaces and cargo pump rooms shall be of an approved type and shall be tested in compliance with the requirements of IMO circular MSC/Circ.1165, as amended by IMO circular MSC.1/Circ.1269.

All distribution piping, valves, release piping and nozzles in protected spaces shall be made of materials with a melting point exceeding 925° C. Piping and associated equipment shall be fastened securely.

#### **3.1.5 Starting of systems.**

**3.1.5.1** A system shall be put into operation without any supplementary change-over at the station and shall operate quickly and efficiently under all service conditions, including those when the temperature is below zero and during a fire.

The means of control of any fixed gas fire extinguishing system shall be readily accessible, simple to operate and shall be grouped together in as few locations as possible at positions not likely to be cut off by a fire in a protected space.

At each location there shall be clear instructions relating to the operation of the system having regard to the safety of personnel.

**3.1.5.2** The possibility of spontaneous starting of a fire extinguishing system shall be excluded under any service conditions, including the effect of such factors as pitching and rolling, shaking and vibration.

**3.1.5.3** Starting controls shall be so arranged, and if necessary so protected, that a free access to them is provided and their mechanical damage is precluded.

**3.1.5.4** Arrangements shall be provided for the attachment of seals to the starting controls of the system.

**3.1.5.5** Irrespective of remote control provision the system shall be capable of being manually started directly at the fire extinction station, and the pump - at the place of its location.

**3.1.5.6** Remote control system (by air, nitrogen, carbon dioxide, etc.) shall be provided with two cylinders, gas quantity in each of them being sufficient for a single start.

**3.1.5.7** Where provision is made for mechanical devices in the remote starting system, their valves shall be controlled with the help of hand wheel or levers to be positively connected to the valve stems or spindles.

**3.1.5.8** Automatic discharge of fire extinguishing medium is not permitted except for cases stipulated by **3.3**, **3.6.3** and **3.11.2.7**.

### **3.1.6 Protection of vehicle, special category and ro-ro spaces<sup>8</sup>.**

**3.1.6.1** Vehicle spaces and ro-ro spaces, which are not special category spaces and are capable of being sealed from a location outside of the cargo spaces, shall be fitted with one of the following fixed fire-extinguishing systems:

**.1** a fixed gas fire-extinguishing system complying with the provisions of the Fire Safety Systems Code (refer to **3.8.1**);

**.2** a fixed high-expansion foam fire-extinguishing system complying with the provisions of the Fire Safety Systems Code (refer to **3.7.3.3**); or

**.3** a fixed water-based fire fighting system for ro-ro spaces and special category spaces complying with the provisions of the Fire Safety Systems Code and **3.1.6.2.1 – 3.1.6.2.4**.

**3.1.6.2** Vehicle spaces and ro-ro spaces not capable of being sealed and special category spaces shall be fitted with a fixed water-based fire-fighting system for ro-ro spaces and special category spaces complying with the provisions of the Fire Safety Systems Code which shall protect all parts of any deck and vehicle platform in such spaces. Such a water-based fire-fighting system shall have:

**.1** a pressure gauge on the valve manifold;

**.2** clear marking on each manifold valve indicating the spaces served;

**.3** instructions for maintenance and operation located in the valve room; and

**.4** a sufficient number of drainage valves to ensure complete drainage of the system (refer to **7.6.12.3**, Part VIII «Systems and piping»).

## **3.2 WATER FIRE MAIN SYSTEM**

### **3.2.1 Number and capacity of fire pumps.**

**3.2.1.1** In ships provision shall be made for pumps, fire mains, hydrants and hoses complying as applicable with the requirements of this Chapter.

The number of fixed independently driven fire pumps and the minimum pressure at all hydrants at water delivery through any adjacent hydrants by two pumps simultaneously of the quantity of water specified in **3.2.5.1** shall be not less than those specified in Table 3.2.1.1, the length of hoses complying with the requirements of **5.1.4**, and the nozzle outlet diameters complying with **5.1.5**.

**Table 3.2.1.1**

Gross tonnage	Passenger ships		Other ships	
	Number of pumps	Minimum pressure at hydrants, in MPa	Number of pumps	Minimum pressure at hydrants, in MPa
Under 500	2	0,30	1	0,20
500 to 1000	2	0,30	2	0,25



1000 to 4000	2	0,30	2	0,25
4000 to 6000	3	0,40	2	0,25
6000 and upwards	3	0,40	2	0,27

Notes: 1. The number of pumps indicated above does not include the emergency fire pump, if fitted.  
2. The maximum pressure at any hydrant shall not exceed pressure, at which the effective control of a fire hose can be demonstrated.

For ships of restricted areas of navigation, which are not engaged in international voyages (except for passenger ships) and have a gross tonnage under 2000, the requirement of Table 3.2.1.1 concerning the number of pumps may be waived subject to a special agreement with the Register.

On floating cranes with a gross tonnage under 2000, one fire pump may be installed

The pressure developed by the fire pumps shall be sufficient to ensure the operation of other fire extinguishing systems using water (e.g., for pressure water spraying, froth extinguishing, etc.) and supplied from the same fire pumps.

8 Refer to IMO MSC.338(91) « Protection of vehicle, special category and ro-ro spaces».

In passenger ships with signs **B-R3-S**, **B-R3-RS**, **C-R3-S**, **C-R3-RS** and **D-R3-S**, **D-R3-RS** with a length of 24 meters and over, the number of fixed fire pumps, the minimum pressure at the location of any hydrant, in the case of water supply through hydrants in the required amount, shall not be less than specified in **3.2.1.12**.

**3.2.1.2** In passenger ships of 1000 gross tonnage and upwards, the of sea connections, fire pumps and their sources of power shall be so arranged that, in the event of a fire in any one compartment, all the fire pumps will not be put out of action.

Passenger ships of less than 1000 gross tonnage, passenger ships with signs **B-R3-S**, **B-R3-RS**, **C-R3-S**, **C-R3-RS** and **D-R3-S**, **D-R3-RS** with a length of 24 meters and over, intended to carry 250 passenger and over and cargo ships of 2000 gross tonnage and upwards shall be provided with an emergency fire pump of a capacity not less than 25 m<sup>3</sup>/h and cargo ships of less than 2000 gross tonnage shall be provided with an emergency fire pump of a capacity not less than 15 m<sup>3</sup>/h independently driven, if a fire in any one compartment could put all the pumps or their sources of power out of action. Source of power and sea connection shall be located outside the space where the main fire pumps or their sources of power are located (refer also to **3.2.4.2** and **3.2.5.7**).

**3.2.1.3** Emergency fire pump, if fitted, shall meet the requirements of **3.2.4**.

**3.2.1.4** In addition to the provisions of **3.2.1.2** in passenger ships of less than 1000 gross tonnage and in cargo ships the emergency fire pump shall be also fitted in the following cases:

**.1** the two main fire pumps, their sea connections and sources of power are located within compartments separated at least by "A-0" class divisions, so that a fire in any one compartment will not put both fire pumps out of action;

**.2** one main fire pumps is located in a compartment having more than one bulkhead or deck adjacent to the compartment containing the other main fire pump.

**3.2.1.5** The total capacity of fixed fire pumps, except for an emergency pump, if any, with the pressure at any hydrant not less than that specified in Table 3.2.1.1, shall ensure discharge of water for fire fighting in a quantity, in m<sup>3</sup>/h, not less than

$$Q = km^2 \quad (3.2.1.5)$$

where  $m = 1,68 \sqrt{L(B+D)+25}$ ;

$L$  = length of the ship (refer to **1.1.3**, Part II "Hull"), in m, excluding the length of the spoil hopper, if no tanks and other storages for combustible materials are installed therein, in hopper dredgers and hopper barges;

$B$  - moulded breadth, in m;

$D$  - depth to the bulkhead deck amidships, in m;

$k$  - coefficient equal to:

0,016 for passenger ships having subdivision index  $R$  equal to, or more than, 0,5;

0,012 for passenger ships having subdivision index  $R$  less than 0,5;

0,008 for all other ships;

$R$ - subdivision index determined in accordance with **2.3**, Part V "Subdivision".

In all cases for passenger ships and cargo ships of more than 500 gross tonnage the required fire pumps shall provide the following water supply for fire-fighting purposes at the pressure specified in Table 3.2.1.1:

.1 in passenger ships - not less than two thirds of the quantity sucked from the holds by bilge pumps;

.2 in cargo ships - not less than four thirds of the quantity sucked from the holds of the same size passenger ship by each independent bilge pump according to the requirements of 7.1, Part VIII "Systems and Piping".

**3.2.1.6** For catamarans and similar ships, the total capacity of fire pumps shall be determined as twice the capacity value for one hull.

**3.2.1.7** In all ships other than passenger ships the total capacity of fire pumps need not exceed 180 m<sup>3</sup>/h, unless a larger capacity is required in order to ensure the simultaneous operation of other systems using water.

**3.2.1.8** The capacity, pressure head and number of fire pumps for floating docks shall be chosen in accordance with the quantity of water required by the largest cargo ship which the dock can carry, for the operation of the water fire main system.

On non-self-contained floating docks receiving water for the water fire main system from the shore the emergency fire pump need not be installed.

**3.2.1.9** Each fixed fire pump except of emergency shall be capable of supplying at least two jets of water required by 3.2.6.2.

**3.2.1.10** The capacity of each fixed pump, other than an emergency pump, shall not be less than 80% of the total required capacity divided by the required number of fire pumps, but in any case not less than 25 m<sup>3</sup>/h.

If the number of fire pumps exceeds the required number, the feed of the additional pumps shall be at least 25 m<sup>3</sup>/h and it shall be sufficient to support at least two nozzles in accordance with 3.2.6.2.

**3.2.1.11** If other fire extinguishing systems using water supplied by fixed fire pumps are provided in ships, the capacity of these pumps shall be sufficient for the operation of the water fire main system having the capacity not less than 50 % determined by Formula (3.2.1.5) and for parallel operation of one of the other systems requiring the largest quantity of water. In the case concerned the quantity of water for the water fire main system shall be sufficient for delivering at least two jets of water through the largest nozzles used in the ships, but more than six jets and more than 90 m<sup>3</sup>/h for cargo ships are not required. Possible increase of water discharge through each hydrant due to the pressure rise in the pipes required for the operation of the other fire extinguishing systems shall be taken into consideration.

The quantity of water for fire extinguishing systems, other than for the water fire main system, shall be determined in accordance with the requirements in 3.3.2.2, 3.4.2, 3.5.2 (within one main vertical zone), 3.6.5 and 3.7.

**3.2.1.12** In passenger ships with signs **B-R3-S**, **B-R3-RS**, **C-R3-S**, **C-R3-RS** and **D-R3-S**, **D-R3-RS** with a length of 24 meters and over, the number of fixed fire pumps shall be as follows:

.1 in ships intended to carry more than 500 passengers, at least three one of which may be powered by the main engine;

.2 in ships intended to carry 500 passengers or less, at least two of which may be powered by the main engine.

Necessary fire pumps shall provide water supply in the amount of not less than two thirds of the amount provided by drainage pumps when pumping water from the holds and, in the case of water supply in the required amount, the minimum pressure at the location of any hydrant:

in ships intended for the carriage of more than 500 passengers - 0.41 MPa;

in ships intended for the carriage of 500 passengers and less - 0.31 MPa.

**3.2.1.3** Fixed water fire system may not be installed on ships, other than passenger ships, with a crew of less than 3 persons.

In ships with a crew of less than 3 persons and in ships without a crew, not equipped with propulsion systems and an autonomous source (s) of energy, the water fire system shall be arranged according to the applicable requirements of 6.5 or 8.11 as the case may be.

### **3.2.2 Location of fire pumps.**

**3.2.2.1** In passenger ships of 1000 gross tonnage and upwards, passenger ships with signs **B-R3-S**, **B-R3-RS**, **C-R3-S**, **C-R3-RS** and **D-R3-S**, **D-R3-RS** with a length of 24 meters and over, intended to carry 250 passenger and upwards the sea connections, fire pumps and their sources of power shall be so located as to ensure that a fire in any one compartment will not put all pumps out of action.

**3.2.2.2** In catamarans and similar ships, for which not less than two pumps are required in compliance with Table 3.2.1.1, it is recommended that one pump be fitted in each hull.

In this case, water supply by each pump to the water fire main of any hull of the ship shall be ensured.

### **3.2.3 Basic requirements for fire pumps.**

**3.2.3.1** In all self-propelled ships, fixed fire pumps shall have an independent power source.

In cargo ships between 500 and 1000 gross tonnage, one of the pumps shall have an independent drive.

In passenger ships of less than 150 gross tonnage with the main propulsion machinery of power output less than 220 kW, the pumps driven by the main engine may be used provided that the propulsion unit (engine-shaft-propeller) is so designed as to permit of fire pump operation when the ship is not under way.

**3.2.3.2** Fixed fire pumps including an emergency pump may be used for other shipboard services, if the ship is provided with at least two independently driven pumps, one of which is at all times kept readily available for its direct purpose.

Where in conformity with Table 3.2.1.1 only one fire pump is fitted, it may be used for other purposes requiring short-time consumption of water (flushing out of decks, hawse pipes etc.).

A fire pump may be used for emergency drainage of machinery spaces.

**3.2.3.3** In cargo ships where other pumps, such as general service, bilge, ballast, and etc., are fitted in a machinery space, provision shall be made to ensure that at least one of these pumps, having the capacity and pressure required by **3.2.1.11** and Table 3.2.1.1, is capable to supply water to the fire main. However, if the ship is equipped with the required number of fire pumps of necessary capacity and pressure, then it is sufficient to have a connection of the general service pump with water fire main system. Such pumps shall meet the requirements of **3.2.3.2** and **3.2.3.4**.

**3.2.3.4** Pumps and piping intended for fire-fighting purposes shall not be used for the pumping of oil and other flammable liquids, nor as ballast pumps for tanks used for alternate carriage of fuel oil and water ballast.

**3.2.3.5** Fire pumps shall be fitted with a pressure gauge on the discharge side.

Pumps capable of developing in the fire main hydrants and hoses a pressure exceeding the permissible value shall be provided with relief valves set to operate at a pressure not more than 10 % in excess of the fire main working pressure, and having the pipes to discharge water into the suction main. Location and adjustment of these valves shall prevent excessive pressure in any part of the fire main.

**3.2.3.6** Fixed fire pumps and their sea valves shall be located below the light-draught waterline of the ship. Where the pumps are located above the lowest possible waterline, efficient arrangements shall be made for self-priming.

A fixed emergency pump shall be installed in compliance with **3.2.4**.

Fire pumps installed outside machinery spaces of category A shall have an independent sea valve in each compartment in which they are located.

In the case of ice class ships, at least one of the pumps shall be connected with the heated ice box (refer to **4.3.1** and **4.3.3**, Part VIII "Systems and Piping").

**3.2.3.7** All pumps, including the emergency pump, shall be placed in spaces with positive temperature.

**3.2.3.8** In passenger ships of 1000 gross tonnage and upwards as well as in ships with signs **B-R3-S**, **B-R3-RS** with a length of 24 meters and over, intended to carry 250 passenger and upwards and in all passenger ships with periodically unattended machinery spaces containing fire pumps, the water fire main system shall constantly be under pressure providing immediate the supply of at least one effective water jet from any of fire hydrants and automatic start of one of the required fire pumps at a drop of pressure.

In passenger ships of less than 1000 gross tonnage, the water fire main system shall enable the automatic and remote start-up of at least one fire pump from the navigation bridge. If the pump starts automatically or if the bottom valve can not be opened from location where the pump is remotely started, the bottom valve shall always be kept open.

**3.2.3.9** In cargo ships with a periodically unattended machinery space containing fire pumps or when only one person is required on watch provision shall be made for remote starting of one of the main fire pumps from the navigation bridge and from fire station if available and for immediate water supply in the fire main without additional opening of the valves in the pump room. At the location of such arrangement a water pressure indicator shall be installed.

Where water fire main system is under pressure as required in **3.2.3.8**, remote starting need not be provided.

In ships of less than 1600 gross tonnage, fulfilment of this requirement may not be provided, if starting arrangement of the fire pump in machinery space is easily accessible.

### **3.2.4 Fixed emergency fire pump.**

**3.2.4.1** The emergency pump shall be driven by a diesel engine or an electric motor supplied with power from the emergency source of power.

**3.2.4.2** The pump, its sources of power and sea connections shall be so located as not to be put out of action in the event of a fire within the spaces where the main fire pumps are located.

The emergency fire pump, its seawater inlet, and suction and delivery pipes and isolating valves shall be located outside the machinery space. If this arrangement cannot be made, the sea chest may be fitted in the machinery space if the sea inlet valve is remotely controlled from a position in the same compartment as the emergency fire pump and the suction pipe is as short as practicable. Short lengths of suction or discharge piping may penetrate the machinery space or compartments where main fire pumps are installed, provided they are enclosed in a substantial steel casing or are insulated to "A-60" class standards in accordance with IMO circular MSC.1/Circ.1456. The pipes shall have substantial wall thickness, but in no case less than 11 mm, and shall be welded except for the flanged connection to the sea inlet valve.

Location of the pump and its drive shall allow free access to them for maintenance and repair.

**3.2.4.3** Where the pump is located above the lowest possible waterline, efficient arrangements shall be made for self-priming.

Under all conditions of heel, trim, pitch and roll, likely to be encountered in the ship service, the total suction head and the net positive suction head shall provide the fulfilment of the requirement of **3.2.4.6**.

The design conditions for fulfilment of these requirements are defined in IMO circular MSC.1/Circ.1388.

**3.2.4.4** The space containing the emergency fire pump shall not be contiguous to the boundaries of machinery spaces of category A or those spaces containing main fire pumps. Where this is not practicable, the common bulkhead between the two spaces shall comply with the requirements of Table 2.3.3-1 for control stations.

When a single access to the emergency fire pump room is through another space adjoining a machinery space of category A or the spaces containing the main fire pumps, "A-60" class boundary is required between that other space and the machinery space of category A or the spaces containing the main fire pumps.

No direct access shall be permitted between the machinery space and the space containing the emergency fire pump and its source of power. When this is impracticable, an arrangement may be accepted where the access is by means of an air-lock where the door to the machinery space shall be made to "A-60" class and the second door shall be made at least of steel, each of the doors being self-closing and gastight, or through a watertight door capable of being operated from a space remote from the machinery space and the space containing the emergency fire pump and unlikely to be cut off in the event of fire in those spaces. In such cases a second means of access to the space containing the emergency fire pump and its source of power shall be provided.

No hold-back hooks are permitted for the above doors.

**3.2.4.5** Any diesel driven source of power supplying the emergency fire pump shall be easily started manually in cold condition at a temperature up to 0°C. If this source of power is installed in unheated space, it shall be fitted with electrical means of cooling water or lubricating oil heating, which ensure its quick start. If manual start of this source of power is practically impossible, then on agreement with the Register starting arrangements or other compressed air, hydraulically or electrically driven starting mechanisms shall be used. These mechanisms shall be such as to provide starting of the source of power at least six times during half an hour and, at least twice during the first 10 min.

**3.2.4.6** The emergency fire pump capacity shall be not less than 40 % of the total required capacity of fire pumps determined, considering **3.2.1.2** and **3.2.1.7**.

**3.2.4.7** The emergency fire pump capacity shall comply with **3.2.4.6**.

Where a fixed pressure water-spraying system installed for the protection of the machinery space in accordance with **3.4** is supplied by the emergency fire pump, then the emergency fire pump capacity shall be adequate to supply the system at the required pressure plus two jets of water.

The capacity of the two jets shall be calculated for the largest nozzles used in the ship at not less than 25 m<sup>3</sup>/h. When determining the largest nozzles, the nozzles in the space where the main fire pumps are located may not be considered. The capacity of the fire pump with the nozzle diameter of 16 mm shall be 16 m<sup>3</sup>/h, the capacity of the pump with the nozzle diameter of 19 mm - 23,5 16 m<sup>3</sup>/h accordingly, the pressure at hydrants being 0,27 MPa.

**3.2.4.8** Where the sea inlet valve is in the machinery space, measures shall be taken so that the valve can be opened in the event of fire.

### **3.2.5 Piping.**

**3.2.5.1** The diameters of the fire main and water service pipes shall be sufficient for the effective distribution of the maximum required discharge from two fire pumps operating simultaneously. In cargo ships, except those specified in **6.9.2**, the diameter need only be sufficient for the discharge of 140 m<sup>3</sup>/h.

In ships of 500 gross tonnage and upwards and floating cranes (refer to **3.2.5.6**) the pipes of the fire main shall be rated at a working pressure of at least 1 MPa.

**3.2.5.2** To prevent freezing, the pipelines of the water fire main system extended to open decks or non-heated spaces shall be provided with shut-off fittings mounted in heated spaces, and with water drainage arrangements.

**3.2.5.3** Each fire pump shall be fitted with shut-off valves on the suction and discharge pipes.

The use of slide valves on the suction pipe is permitted.

In ships of 500 gross tonnage and upwards the valves on the discharge side of the pumps shall be of a non-return shut-off type.

**3.2.5.4** In oil tankers, the fire main shall comply with the following supplementary requirements:

**.1** in the fire main at the poop front in a protected position as specified in IMO circular MSC.1/Circ.1456 and in easily accessible places on the cargo oil tank deck, the isolation valves shall be fitted at intervals of not more than 40 m. Each of such valves shall be provided with an information plate to indicate that the valve shall be kept permanently open under normal service conditions;

**.2** before each isolation valve on the fire main there shall be fitted twin fire hydrants of 70 mm diameter so located that they are equally spaced, over the length of the ship and the fulfilment of the requirements of **3.2.6.2** is ensured;

**.3** before the cut-off valve fitted in the poop there shall be a branch pipe on either side, led out from the fire main to the forward part of the poop deck; the diameter of each branch pipe shall be sufficient for supplying water through two fire hoses connected to two hydrants fitted at the end of each branch; in ships of 1000 gross tonnage and upwards the diameter of each hydrant provided shall be about 70 mm, and in ships of less gross tonnage this diameter shall be about 50 mm.

Where fire pumps are fitted forward of the cargo tanks, two more similar pipes branching from the fire main of the same diameter as above shall be provided on the after part of the forecastle deck, an isolation valve being fitted on the fire main within the erection, after the branches.

**3.2.5.5** In catamarans and similar ships, each hull shall be provided with a water fire main system including water hydrants, hoses and nozzles.

**3.2.5.6** In all ships of 500 gross tonnage and upwards, and in floating cranes facilities shall be available on the open deck enabling an international shore connection to be used on either side of the ship (refer to **5.1.18**).

**3.2.5.7** Isolating valve to separate the piping within the machinery space of category A containing the fire pump (or pumps) from the main outside it shall be fitted in piping in easily accessible position (outside the machinery space).

The fire main shall be so arranged that when the isolating valves are shut all the hydrants on the ship, except those fitted in the piping separated from water supply, can be supplied with water by another fire pump located outside the machinery space.

### **3.2.6 Fire hydrants.**

**3.2.6.1** Each fire hydrant shall have a shut-off valve and a standard quick-acting coupling.

Hydrants fitted on open decks shall also have quick-acting plugs, or equivalent device.

**3.2.6.2** The number and arrangement of fire hydrants shall ensure at least the delivery of two water jets from different hydrants, one of the jets being delivered through a hose of standard length as stipulated under **5.1.4.1**, to any area of the ship which is generally accessible to passengers and crew during the voyage and to any part of any cargo space that is empty, ro-ro cargo space and for special-category spaces - to any part of the space through standard length hoses. In the latter case, two jets shall be delivered to any part of the space through standard length hoses. Besides, such hydrants shall be located near entrance to the protected spaces. In passenger ships the number and location of fire hydrants in the accommodation, service and machinery spaces shall be such that this requirement may be complied with when all watertight doors and all doors in main vertical zones are closed.

On open decks for containers two jets of water shall be delivered onto each accessible vertical side of the container by standard length hoses.

**3.2.6.3** It is not recommended that fire hydrants are located closer than 20 m from each other in the internal spaces and more than 30 m on open decks.

**3.2.6.4** Fire hydrants shall not be placed at the ends of dead-end corridors, in special electrical spaces or closed or rarely attended spaces.

**3.2.6.5** In ships, carrying deck cargoes fire hydrants shall be located to ensure easy access, while the pipes shall be located to avoid being damaged by cargo.

**3.2.6.6** In machinery space of category A at least two hydrants shall be provided.

**3.2.6.7** In all ships there shall be fitted a fire hydrant located in the forward part of the propeller shaft tunnels.

**3.2.6.8** All fire hydrants shall be painted red.

**3.2.6.9** In passenger ships two fire hydrants shall be provided in the shaft tunnel, being one of the means of escape, in the proximity to the machinery space of category A.

Where some other space is used as a means of escape, two fire hydrants shall be provided therein at the entrance to the machinery space of category A. Provision of **3.2.6.7** need not be met in this case.

**3.2.7 Water fire main systems of ships marked C-R3-S, C-R3-RS and D-R3-S, DR3-RS in their class notation, with the length less than 24 m.**

**3.2.7.1** The requirements of this Subsection apply to water fire systems of ships marked C-R3-S, C-R3-RS and D-R3-S, DR3-RS in their class notation, with the length less than 24 m.

**3.2.7.2** Every ship shall be fitted with a fixed fire pump capable of supplying at least one jet of fire-fighting water from a fire hose with monitor nozzles of 12, 16 or 19 mm, that is connected to a hydrant, in the amount of at least two-thirds of the amount supplied by bilge pumps when pumping water from holds and, where a sufficient amount of water is supplied through the hydrants, the minimum pressure at the level of each hydrant:

- in ships carrying more than 500 passengers – 0.41 MPa;
- in ships carrying 500 passengers and less – 0.31 MPa.

**3.2.7.3** In all ships carrying more than 250 passengers an additional fixed fire pump driven from an energy source shall be fitted. Such pump with an energy source and a sea chest shall not be positioned in the same machinery space in which the main fire pump is located. It shall supply at least one jet of water from any fire hydrant under pressure of not less than 0.31 MPa in the amount not less than 25 m<sup>3</sup>/h.

**3.2.7.4** Sanitary, ballast, bilge or general purpose pumps may be used as fire pumps.

**3.2.7.5** All ships shall have fire mains with the diameter such as to allow efficient distribution of the maximum amount of water supplied by the concerned fire pump. The number and arrangement of fire hydrants shall be such as to ensure that at least one jet of water reaches any part of the ship from a single length of hose.

**3.2.7.6** All ships shall be fitted with at least one fire hose for each hydrant.

**3.2.7.7** In ships including normally unattended machinery spaces or spaces continuously manned with a single crew member, provision shall be made for immediate water supply from the fire main under proper pressure by remote actuation of the main fire pump from the navigation bridge and the fire station, where any, or by way of maintaining steady pressure in the fire main.

**3.2.7.8** Every fire pump shall be provided with a non-return shut-off valve on its discharge side.

### **3.3 SPRINKLER SYSTEM**

#### **3.3.1 General.**

**3.3.1.1** Automatic sprinkler systems shall be a wet pipe type, as specified by IMO circular MSC/Circ.1165. Upon agreement with the Register for small exposed sections, as well as at control stations, where water may cause damage to essential equipment, may be fitted with a dry pipe system or a pre-action system as permitted by IMO circular MSC/Circ.1165.

Any system sections exposed to low temperatures during operation shall have proper protection against freezing.

Particular attention should be paid to the water quality specification provided by the system manufacturer to prevent internal corrosion and contamination of sprinklers due to corrosion products or scale-forming minerals.

**3.3.1.2** A sprinkler system shall be automatically set in operation at temperatures in the protected space rising to the values indicated in **3.3.4.2**.

**3.3.1.3** The automatic sprinkler system shall be kept charged at the necessary pressure and shall have provision for a continuous supply of water as required in the present Chapter.

**3.3.1.4** The air cylinder, compressor, pump and the pipes of the sprinkler system, except for the piping connecting the sprinkler system to the water fire main system, shall be independent of all other systems.

**3.3.1.5** A sprinkler pump and a pressure tank shall be arranged outside the protected space, at an adequate distance from the machinery spaces of category A. A gauge indicating the pressure in the system shall be provided at each section stop valve and at a central control station.

**3.3.1.6** Means shall be provided for testing the automatic operation of the sprinkler pump on reduction of pressure in the system.

**3.3.1.7** When sprinkler systems equivalent to the systems specified in the present Chapter are used, they shall be approved by the Register according to the Guidelines adopted by the IMO resolution A.800(19) considering amendments introduced by IMO resolutions MSC.265(84)/Corr.1 and MSC.284(86). When approving such systems special consideration shall be given to the fulfillment of the requirements of **3.3.1.1** to **3.3.1.3**, **3.3.1.6**, **3.3.2.1**, **3.3.4.1**, **3.3.5.1** and **3.3.5.2**.

### 3.3.2 Sprinkler pumps.

**3.3.2.1** An independent power pump shall be provided solely for the purpose of continuing automatically the discharge of water from the sprinklers. The pump shall be brought into action automatically by the pressure drop in the system before the standing fresh water charge in the pressure tank is completely exhausted.

**3.3.2.2** The pump and piping system shall be capable of maintaining the necessary pressure at the level of the highest sprinkler to ensure a continuous flow rate of water sufficient for the simultaneous coverage of the minimum floor area of 280 m<sup>2</sup> at the application rate specified in 3.3.4.1.

For application to a ship with a total protected area of less than 280 m<sup>2</sup>, in particular ships with the sign **C-R3-S, C-R3-RS** and **D-R3-S, D-R3-RS** with a length of less than 40 m, the Register may specify the appropriate area for sizing of pumps and supply components.

**3.3.2.3** The pump shall be fitted on the delivery side with a test valve with a short open-ended discharge pipe. The effective area through the valve and pipe shall be adequate to permit the release of the required pump output while maintaining the pressure in the system specified in 3.3.3.2.

**3.3.2.4** The sea inlet to the pump shall wherever possible be in the space containing the pump and shall be so arranged that when the ship is afloat it will not be necessary to shut off the supply of sea water to the pump for any purpose other than the inspection or repair of the pump.

**3.3.2.5** Provision shall be made for connection of the main supply piping with the ship's fire main.

A lockable non-return shut-off valve shall be fitted at the connection concerned.

**3.3.2.6** There shall be not less than two sources of power for the pumps. Where the sources of power are electrical, the pump shall be supplied according to 4.3.1.5, 19.1.1.1, 19.1.1.2 and 19.1.2.1.7, Part XI "Electrical Equipment".

One of the sources of power for the pump may be an internal combustion engine which shall be so situated (besides compliance with the instructions of 3.3.1.5) that a fire in any protected space will not affect the air supply to the machinery.

### 3.3.3 Pressure tank.

**3.3.3.1** The pressure tank shall be fitted with:

- .1 an automatic pressure maintaining device;
- .2 glass gauge;
- .3 a relief valve;
- .4 a pressure gauge.

**3.3.3.2** The pressure tank shall contain a standing charge of fresh water equivalent to the volume of water which would be discharged in one minute by the sprinkler pump.

The volume of the pressure tank shall be equal to at least twice that of the charge of water specified above.

Arrangements shall be made for maintaining such air pressure in the tank as to ensure that where the perennial supply of fresh water in the tank has been used the pressure in that tank is not less than a working pressure at the sprinkler plus a hydrostatic pressure from the tank bottom to the highest sprinkler.

Suitable means of replenishing the air under pressure and of replenishing the fresh water charge in the tank shall be provided. Means shall be also provided to prevent the passage of sea water into the tank.

**3.3.3.3** Pneumatic pressure tanks shall comply with the requirements for pressure vessels set out in Part X "Boilers, Heat Exchangers and Pressure Vessels".

### 3.3.4 Sprinklers.

**3.3.4.1** Sprinklers shall be placed in an overhead position and spaced in a suitable pattern to maintain an average application rate of not less than 5 l/min per 1 m<sup>2</sup> over the horizontal area of the protected space.

The Register may permit the use of other application rate depending on structural features of the protected space.

While protecting windows by sprinklers, the requirements of 2.2.4.4 shall be met.

**3.3.4.2** The sprinklers shall be resistant to corrosion by marine atmosphere. In accommodation and service spaces the sprinklers shall come into operation within the temperature range from 68 to 79°C, except that in locations such as drying rooms where high ambient temperatures might be expected, the operation temperature may be increased by not more than 30 8C above the maximum deckhead temperature. In saunas, provision shall be made for empty sprinkler systems with the upper operating limit of 140 8C. Refrigerated chambers may be fitted with dry pipe sprinkler systems.

### 3.3.5 Control valves.

**3.3.5.1** Each section of sprinklers shall include means for giving a visual and audible alarm signal automatically at one or more indicating units whenever any sprinkler comes into operation. Such alarm systems shall be such as to indicate if any fault occurs in the system. Such units shall indicate in which section served

by the system a fire has occurred and shall be centralised on the navigation bridge or in the continuously manned control station and, in addition, visible and audible alarms from the unit shall also be placed in a position other than on the aforementioned spaces to ensure that the indication of fire is immediately received by the crew.

**3.3.5.2** Switches shall be provided at one of the indicating positions referred to in **3.3.5.1** which will enable the alarm and the indicators for each section of sprinklers to be tested. A list or plan shall be displayed at each indicating unit showing the spaces covered and the location of the zone in respect of each section. Suitable instructions for testing and maintenance shall be available.

**3.3.5.3** A test valve shall be provided for testing the automatic alarm for each section of sprinklers by a discharge of water equivalent to the operation of one sprinkler. The test valve for each section shall be situated near the stop valve for that section.

### **3.3.6 Pipes.**

**3.3.6.1** Sprinklers shall be grouped into separate sections, each of them shall contain not more than 200 sprinklers. In passenger ships, any section of sprinklers shall not serve more than two decks and shall not be situated in more than one main vertical zone.

However, the Register may permit such section of sprinklers to serve more than two deck or be situated in more than one main vertical zone, provided it shall not reduce, on the Register opinion, the fire protection of the ship.

**3.3.6.2** Provision shall be made in each section for purging the pipes with compressed air and flushing them with fresh water.

**3.3.6.3** Each section of sprinklers shall be capable of being isolated by one stop valve only after which a gauge shall be provided.

The stop valve in each section shall be readily accessible in a location outside of the associated section or in cabinets within stairway enclosures. The valve's location shall be clearly and permanently indicated.

Measures shall be taken to preclude unauthorized persons from operating the shut-off valves.

**3.3.6.4** The suction pipes of the pumps feeding a sprinkler system shall be fitted with filters.

**3.3.6.5** The diameters of the pipes of a sprinkler system shall be such as to ensure the operation of sprinklers at the water pressure and the rate of discharge specified in **3.3.2.2** and **3.3.4.1**.

**3.3.6.6** The pipelines of the sprinkler system shall be fitted with non-return shut-off valves preventing sea water from penetrating into the pressure tank and the leakage of water from the tanks and the system.

## **3.4 PRESSURE WATER-SPRAYING SYSTEM**

**3.4.1** In machinery spaces of category A as well as in cargo pump rooms specified in **1.5.7.1** pressure water-spraying system shall be supplied from an independent pump which shall be automatically put into action by a pressure drop in the system and from the fire main. A non-return shut-off valve shall be fitted on the connection line with the fire main.

The pressure water-spraying system for ro-ro cargo spaces, vehicle spaces (refer to **1.5.4.3** and **1.5.4.4**) and special category spaces (refer to **1.5.9**) shall comply with the provisions of IMO circular MSC.1/Circ.1430 "Revised Guidelines for the Design and Approval of Fixed Water-Based Fire-Fighting Systems for Ro-Ro Spaces and Special Category Spaces". Such system shall protect all portions of any deck and sites for vehicles in the specified spaces, shall have manual control and pressure gauge at every distribution box with clear marking indicating protected spaces, as well as suitable maintenance and service instructions located at the valves section. Considering a substantial loss of stability, which may occur due to large concentration of water on decks of specified spaces during system operation, measures shall be provided as stipulated in **7.6.12**, Part VIII "Systems and Piping".

In spaces where flammable liquids are stored the system may be supplied only from the fire main.

Where high-pressure water-spraying system is used, the necessity for the reserve supply for such system shall be determined in each case on agreement with the Register, the rate of water supply shall be provided not less than specified in **3.4.2.1**.

**3.4.2** The number and arrangement of the nozzles shall be such as to ensure an effective average distribution of water in the spaces to be protected of not less than:

- .1** 5 l/min per 1 m<sup>2</sup> of the horizontal area over which fuel oil is likely to spread or cargo space area;
- .2** 1,5 l/min per 1 m<sup>2</sup> of the largest horizontal cross-sectional area of the fish meal hold.

In cargo, working and special spaces, where the system may be divided into sections, the pump shall be capable of supplying two sections of the total length of at least 40 m.

**3.4.3** In machinery spaces of category A of ships specified and in cargo pump rooms in **1.5.7.1** the pressure water-spraying system shall be kept charged under the required pressure up to the valves on the



distribution pipes. The pump supplying the water for the system shall be put automatically into action by a pressure drop in the system.

**3.4.4** Filters preventing the system and spray nozzles from becoming clogged shall be fitted on the suction pipe of the pump supplying the system and on the connection pipe with the fire main.

**3.4.5** Distribution valves shall be placed in easily accessible positions outside the protected spaces so as not to be readily cut off by a fire in the protected space.

Provision shall be made in the protected spaces, where people are permanently present, for remote control of distribution valves from these spaces.

**3.4.6** Spray nozzles shall be placed in the protected spaces as follows:

.1 underneath the ceiling of the space;

.2 above equipment and machinery using fuel oil or other flammable liquids and other fire hazardous objects;

.3 above bilges, double bottom floor coverings and other surfaces over which fuel oil or flammable liquids are likely to spread;

.4 above stacks of fish meal bags.

The spray nozzles shall be so disposed in the protected space that the area covered by one nozzle will overlap that covered by adjacent nozzles.

**3.4.7** Pump of the system providing protection of category A machinery spaces and cargo pump rooms shall ensure a supply of water at the required pressure to all sections of the system in any compartment to be protected. The pump and its controls shall be installed outside the spaces to be protected.

The pump may be driven by independent internal combustion machinery which shall be so situated that a fire in the protected space will not affect the air supply to the machinery. If the pump is electrically driven from the emergency generator, the generator shall comply with the requirements of Section 9, Part XI "Electrical Equipment".

**3.4.8** Average rate of water supply specified in **3.4.2**, shall be increased for the following spaces:

.1 20 l/min per 1 m<sup>2</sup> for boilers frontal parts and surfaces, fuel oil units, centrifugal separator (other than bilge water separators), and fuel filters;

.2 10 l/min per 1 m<sup>2</sup> for pipelines of heated fuel located near the exhaust pipes or similar heated surfaces of main and auxiliary diesel engines;

.3 in accordance with Tables 4-1, 4-2 and 4-3 of IMO circular MSC.1/Circ.1430 for ro-ro and special category spaces.

**3.4.9** Fixed pressure water-spraying system of an approved type complying with the provisions of IMO circular MSC.1/Circ.1268 "Guidelines for the Approval of Fixed Pressure Water-Spraying and Water-Based Fire-Extinguishing Systems for Cabin Balconies" shall be installed to protect cabin balconies of passenger ships where furniture and furnishings on such balconies are not as defined in **2.1.1.9**.

### **3.5 WATER-SCREEN SYSTEM**

**3.5.1** The present Rules provide for the use of the water-screen system in the following cases:

.1 in special purpose ships where, subject to special agreement with the Register, water screens are permitted in lieu of "A" class divisions, in accordance with **2.2.1.2**;

.2 for protection of vertical surfaces of ships hull in compliance with **6.6.6**.

**3.5.2** The design capacity of the pumps supplying the water-screen system shall be sufficient to provide at least 70 l/min per linear metre of the screen length.

### **3.6 DRENCHING SYSTEM**

**3.6.1** The present Rules provide for the use of water drenching system for drenching the racks of magazines (refer to **6.2.2.18** and Table 3.1.2.1), outside surfaces of oil recovery ships (refer to **6.6.4**).

**3.6.2** The drenching system shall be fed from the fire main. The pumps and associated sources of power shall be placed outside the space protected.

**3.6.3** The system shall be started from outside the space.

It is recommended that the system shall be put into action at a temperature rise in the space above admissible.

**3.6.4** The drenching system of magazines and the pressure water-spraying system of the cargo spaces fitted for the carriage of explosives may be used for their flooding in emergency.

**3.6.5** The capacity of the pumps supplying the system shall be sufficient to ensure the following rates of water discharge for drenching magazine racks, 24 l/min per 1 m<sup>2</sup> of the total magazine floor area.

### **3.7 FOAM FIRE EXTINGUISHING SYSTEM**

**3.7.1 General.**

**3.7.1.1** The foam fire extinguishing systems shall be capable to produce air mechanical foam for the use as an extinguishing medium depending on the foam expansion ratio:

- of low expansion ratio (about 10:1);
- of medium expansion ratio (between 50:1 and 150:1);
- of high expansion ratio (about 1000:1).

Foam fire extinguishing systems may include units separately producing, but simultaneously supplying low expansion ratio foam and medium expansion ratio foam (combination foam).

**3.7.1.2** Use shall be made of foam concentrate of types approved by the Register (refer to **1.3.3.1**).

Foam concentrates for generating low expansion and medium expansion foam shall be approved by the Register in accordance with IMO circular MSC.1/Circ.1312 and MSC./Circ.798, respectively.

A foam concentrate for generating high expansion foam shall be approved by the Register in compliance with IMO circular MSC/Circ.670.

**3.7.1.3** The capacity of foam fire extinguishing systems and the quantity of a foam concentrate shall be calculated depending on the foam expansion ratio, foam solution supply rate and operation time of the system given in Table 3.7.1.3 and in **3.7.2.1**.

**Table 3.7.1.3**

Spaces	Foam solution supply rate, in l/min per 1 m <sup>2</sup> , with the foam expansion ratio			Rated time of continuous operation, in min
	10:1	100:1 <sup>1,8</sup>	1000:1	
<b>1</b>	<b>2</b>	<b>3</b>	<b>4</b>	<b>5</b>
Cargo oil tanks and cargo tank deck	(6 ; 0,6; 3) <sup>2</sup>	6 <sup>3</sup>	-	20 <sup>4</sup> /30
Tanks for oil products with a flash point 60°C and above (fuel oil tanks)	6 <sup>3</sup>	4,5 <sup>3</sup>	-	20
Dry cargo holds	-	4 <sup>3</sup>	-	45
Machinery spaces and other spaces whose equipment is oil-fired	-	-	1 <sup>3</sup>	- <sup>5</sup>
Paint lockers, storerooms for flammable liquids, flammable liquefied and compressed gases	-	4,5 <sup>3</sup>	-	20
Hangars for helicopters, enclosed garages, as well as spaces listed in <b>1.5.4.3</b> and <b>1.5.8.1</b>	-	-	- <sup>6</sup>	45
Helidecks <sup>7</sup>	- <sup>7</sup>	- <sup>7</sup>	- <sup>7</sup>	- <sup>7</sup>

<sup>1</sup>The solution supply rates apply to combination-foam production as well.  
<sup>2</sup>The rate of solution supply shall not be less than the greatest of the following:  
**.1** 6 l/min per square metre of the horizontal sectional area of the single tank having the largest such area;  
**.2** 0,6 l/min per square metre of cargo tanks deck area, where cargo tanks deck area means the maximum breadth of the ship multiplied by the total longitudinal extent of the cargo tank spaces;  
**.3** 3 l/min per square metre of the area protected by the largest monitor, such area being entirely forward of the monitor but not less than 1250 l/min.  
<sup>3</sup>For the area of the largest horizontal section of the largest protected space.  
<sup>4</sup>Sufficient foam concentrate shall be supplied to ensure at least 20 min of foam generation in oil tankers fitted with an inert gas system and 30 min in oil tankers not fitted with an inert gas system using largest rate of solution supply stipulated in Footnote <sup>1</sup>.  
<sup>5</sup>Sufficient foam concentrate shall be supplied to ensure foam generation in the volume equal to 5-fold volume of the largest protected space. Foam expansion ratios shall not exceed 1000:1.  
<sup>6</sup>The rate of solution supply shall be sufficient for filling of the protected space volume during 15 min.  
<sup>7</sup>For foam solution supply rate refer to **6.1.1.2.1**  
<sup>8</sup>In passenger ships with sign A, A-R1, A-R2, A-R2-RSN, B-R3-RSN, C-R3-RSN and D-R3 in the ship's class notation - the intensity that provides within 1 min. a layer of foam with a thickness of not less than 1 m when filling the largest protected room

Operation of a deck foam system at its required output shall permit the simultaneous use of the minimum required number of jets of water at the required pressure from the fire main, in compliance with the requirements for water fire main system, which shall be possible on deck over the full length of the ship, in the accommodation, service spaces, control stations and machinery spaces.

**3.7.1.4** Tanks for the storage of foam concentrate shall be fitted with arrangements for filling and draining, a device for watching the level of the liquid and a manhole for cleaning and inspecting. The tanks shall be of sufficient capacity to contain the full required amount of foam concentrate.

If no excessive pressure is required to be created in tanks during the system operation, non-return valves shall be fitted between such tanks and the fire main.

Where a foam concentrate using fresh water is utilized in the high expansion foam system, at fire extinction station there shall be the reserve of water sufficient for at least single foam fill up of the protected space of the largest volume. The remainder of the water may be supplied from ship's storage tanks. Equipment (pumps, fittings, etc.) necessary for supplying fresh water to the tank shall be arranged outside the protected space, be fed from the emergency diesel-generator and have a capacity sufficient to ensure continuous operation of the system as required in Table 3.7.1.3.

**3.7.1.5** The mixers for making aqueous solution of a foam concentrate of the required concentration shall be of an approved type. The mixers shall ensure operation of simultaneously used foam nozzles and/or foam generators.

**3.7.1.6** The main control station of the fixed deck system shall be located in the fire extinction station outside the cargo spaces in the vicinity of accommodation spaces and be easily accessible and ensure control of the system in the event of fire in protected areas. Sampling device for measurement of the percentage of foam concentrate in a solution shall be fitted at the fire extinction station on the fire main at a maximum distance from mixers, the pressure gauge shall be fitted on the pipe supplying water to the system.

The main equipment of the deck system (tanks with a foam concentrate, pumps, mixers, etc) may be located in the engine room.

**3.7.1.7** Deck foam systems applied by a common line from the fire main may be used onboard provided that the foam applicators can be effectively operated by one person when fire extinguishing medium is supplied at a pressure required for monitors. Additional foam concentrate shall be provided for 2 nozzles operation during the period of time according to Table 3.7.1.3.

**3.7.1.8** Fire safety of the enclosed pipe trunk situated within the cargo tanks deck area shall comply with the requirements of IMO circular MSC.1/Circ.1276.

### **3.7.2 Fixed deck systems.**

**3.7.2.1** The expansion ratio of the foam generated by the system shall not generally be greater than 12:1. If the system generates actually low expansion foam with expansion ratio slightly in excess of 12:1, the quantity of the foam concentrate shall be calculated as for the system with foam expansion ratio 12:1. Where the system generates the foam with expansion ratio somewhat below 12:1, the quantity of the foam concentrate shall be proportionally increased.

The system shall be capable of discharging through fixed discharge outlets in no more than 5 min, a quantity of foam sufficient to produce an effective foam blanket over the largest single area over which fuel oil is liable to spread.

Where medium expansion ratio foam is used in oil tankers, the amount of the foam concentrate shall be not less than the rated quantity and sufficient for the operation of the rated number of the foam generators and one monitor during 10 min.

**3.7.2.2** On oil tankers foam shall be supplied by means of monitors and portable foam generators or air-foam nozzles (refer to **5.1.6** and **5.1.19**) to the entire cargo deck area and to any cargo tank whose deck was ruptured. The number and location of the foam main hydrants shall be such as to ensure foam supply to any part of the cargo tanks deck from at least two portable foam generators or air-foam nozzles.

**3.7.2.3** At least 50 % of the foam solution supply rate required in .1 and .2 of Footnote 2 to Table 3.7.1.3 shall be delivered from each monitor.

In ships of less than 4000 t deadweight only portable foam generators or air-foam nozzles may be employed.

However, in such a case the capacity of each generator according to **5.1.19** or nozzle according to **5.1.6.1** shall be at least 25 % of the foam solution supply rate required in .1 and .2 of Footnote 2 to Table 3.7.1.3.

**3.7.2.4** The number and position of monitors shall be such as to comply with **3.7.2.2**, **3.7.2.6** and **3.7.2.8**. The solution-delivering capacity of any monitor shall not be less than indicated in .3 of Footnote 2 to Table 3.7.1.3.

**3.7.2.5** It is recommended that a monitor shall be provided with a changing-over device for alternate supply of water and foam. Pipes branching from the fire main and foam solution supply piping shall be connected to the changing-over device.

In lieu of the changing-over device suitably inter-locked shut-off valves may be fitted.

**3.7.2.6** The distance from the monitor to the farthest extremity of the protected area forward of that monitor shall be not more than 75 % of the monitor throw in still air conditions.

**3.7.2.7** The foam fire main in easily accessible places of the cargo deck shall be fitted with isolation sluice or disc valves spaced 30 m apart. Next to each of such valves there shall be provided an information plate to indicate that the valve shall be kept permanently open under normal service conditions.

Before each isolation valve fitted on the foam piping there shall be twin fire hydrants, 70 mm in inside diameter, for coupling thereto fire hoses with air-foam nozzles located at such distance that the requirements of **3.2.6.2** are met.

Branches from the fire main and foam piping to the monitors shall also be fitted before the isolation valves.

Where medium expansion foam is used, twin fire hydrants shall be substituted by valve chests with a number of fire hydrants equal to 50 % of the required number of foam generators.

**3.7.2.8** In oil tankers, each foam fire extinction station shall be provided with a shut-off device located on the foam fire main before it extends beyond the boundaries of the station.

Before the shut-off device there shall be a branch led out to the forward part of the poop deck, both starboard and port, to monitors and twin fire hydrant, about 70 mm in inside diameter, for coupling thereto fire hoses with air-foam nozzles. For oil tankers of less than 4000 t deadweight, it is sufficient to provide only branch pipes to the said fire hydrants.

Where medium expansion foam is used, twin fire hydrants shall be substituted by valve chests with a number of fire hydrants equal to 50 % of the required number of foam generators.

**3.7.2.9** Foam fire extinguishing system for dry cargo spaces shall meet the following requirements:

**.1** a shut-off valve shall be fitted where the foam fire main is led out to the open deck;

**.2** provision shall be made for valve chests with fire hydrants to be fitted on the foam fire main on both sides. The distance between the valve chests of either side shall not exceed 40 m. The number of fire hydrants in each valve chest shall be equal to 50 % of the required number of foam generators.

**3.7.2.10** If a ship is provided with a fixed low and/or medium expansion foam system, there shall be provided branches from solution pipe line to entrances from the upper deck to machinery spaces as also to the fuel oil filling positions. Each branch shall be fitted with two hydrants for coupling thereto fire hoses with air-foam nozzles or foam generators.

**3.7.2.11** In ships where medium expansion mechanical foam is used, solution piping shall be connected to fire main to provide for the possibility of application of such foam for extinction of fires in accommodation and service spaces through the fire main. For this purpose provision shall be made for an appropriate number of portable foam generators at hydrants in accommodation and service spaces.

**3.7.2.12** The foam shall be supplied to the helidecks with the area limited by the helicopter length via foam monitors or foam generators capable of feeding the foam to any part of the deck, provided that the environmental conditions are suitable for the operation of helicopters.

The system shall feed the foam within at least 5 min. at the rate as specified in Table 3.7.2.12. Helideck or helicopter landing area fixed foam fire extinguishing system on ships and FOP with distinguishing mark **HELIDECK**, **HELIDECK-F** or **HELIDECK-H** in the ship's class notation (refer to **2.2.25**, Part I "Classification") shall meet the requirements of **6.1.2.2.1**.

**Table 3.7.2.12**

Total length of the helicopter, in m	Solution feed rate, l/min
up to 15	250
15 to 24	500
24 to 35	800

**3.7.2.13** Fixed and portable combined foam units may be utilized instead of foam monitors and foam generators.

### **3.7.3 Fixed high expansion foam fire extinguishing system.**

#### **3.7.3.1 General.**

**3.7.3.1.1** The system shall be of approved type and capable of fire extinction and tested based on the procedure in Appendix 1 of IMO circular MSC.1/Circ.1384.

**3.7.3.1.2** The system shall be capable of manual release. It shall be designed to produce foam at the required application rate within 1 min of release. Automatic release of the system shall not be permitted unless

appropriate operational measures or interlocks are provided to prevent any local application systems or other systems from interfering with the effectiveness of the system.

**3.7.3.1.3** The system and its components shall be suitably designed to withstand ambient temperature changes, vibration, humidity, shock, clogging and corrosion normally encountered on ships, which shall be approved based on test results in compliance with the requirements of Appendix 2 to IMO circular MSC.1/Circ.1384.

Piping, fittings and related components inside the protected spaces (except gaskets) shall be designed to withstand 925°C.

**3.7.3.1.4** System piping, foam concentrate storage tanks, components and pipe fittings in contact with the foam concentrate shall be compatible with the foam concentrate and be constructed of corrosion resistant materials such as stainless steel, or equivalent. Other system piping and foam generators shall be full galvanized steel or equivalent.

**3.7.3.1.5** Means shall be provided for the crew to safely check the quantity of foam concentrate and take periodic control samples for foam quality. Means for testing the operation of the system and assuring the required pressure and flow shall be provided by pressure gauges at both inlets (water and foam concentrate supply) and at the outlet of the foam proportioner. A test valve shall be installed on the distribution piping downstream of the foam proportioner, along with orifices which reflect the calculated pressure drop of the system. Distribution pipework shall have self-draining capability and all sections of piping shall be provided with connections for flushing, draining and purging with air. All nozzles shall be able to be removed for inspection in order to prove clear of debris.

**3.7.3.1.6** Operating instructions for the system shall be displayed at each operating position. Besides, installation, operation and maintenance instructions/plans for the system shall be supplied to the ship and be readily available on board. The above instructions shall be in English and the working language of the crew.

**3.7.3.1.7** If an internal combustion engine is used as a prime mover for the sea water pump for the system, the fuel oil tank to the prime mover shall contain sufficient fuel to enable the pump to run on full load for at least 3 h. Sufficient reserves of fuel shall be available outside the machinery space of category A to enable the pump to be run on full load for an additional 15 h. If the fuel tank serves other internal combustion engines simultaneously, the total fuel tank capacity shall be adequate for all connected engines.

**3.7.3.1.8** The arrangement of foam generators and piping in the protected space shall not interfere with access to the installed machinery for routine maintenance activities.

**3.7.3.1.9** The system source of power supply, foam concentrate supply and means of controlling the system shall be readily accessible and simple to operate, and shall be arranged at positions outside the protected space not likely to be cut off by a fire in the protected space. All electrical components directly connected to the foam generators shall have at least an IP 54 rating.

**3.7.3.1.10** The foam generator room shall be ventilated to protect against overpressure, and shall be heated to avoid the possibility of freezing. The foam generators of the outside air foam system shall be located where an adequate amount of fresh air supply can be arranged in compliance with its specification.

**3.7.3.1.11** The quantity of foam concentrate available shall be sufficient to produce a volume of foam equal to at least five times the volume of the largest protected space enclosed by steel bulkheads, at the nominal expansion ratio, or enough for 30 min of full operation for the largest protected space, whichever is greater.

**3.7.3.1.12** Machinery spaces, cargo pump-rooms, vehicle spaces, ro-ro spaces and special category spaces shall be provided with audible and visual alarms within the protected space warning of the release of the system.

The alarms shall operate for the length of time needed to evacuate the space, but in no case less than 20 s.

### **3.7.3.2 Systems for the protection of machinery spaces and cargo pump-rooms.**

**3.7.3.2.1** The system shall be supplied by both main and emergency sources of power in compliance with 4.3.1, 9.3 and 19.1.2 of Part XI "Electrical equipment". The emergency power supply shall be provided from outside the protected space.

**3.7.3.2.2** Sufficient foam-generating capacity shall be provided to ensure the minimum design filling rate for the system is met and in addition shall be adequate to completely fill the largest protected space within 10 min. Where such a machinery space includes a casing (e.g. a machinery space of category A containing internal combustion machinery, and/or a boiler, with an engine casing), the volume of such casing, above the level up to which foam shall be filled to protect the highest positioned fire risk objects within the machinery space, need not be included in the volume of the protected space. The level up to which foam shall be filled to protect the highest positioned fire risk objects within the machinery space shall not be less than:

1 m above the highest point of any such object; or

the lowest part of the casing, whichever is higher.

Fire risk objects include, but may not be limited to, those listed in the definitions of "Machinery spaces of category A" and "Fuel oil unit" in 1.2 Part VII "Machinery Installations". Although not referred to in those definitions, they may also include items having a similar fire risk such as exhaust gas boilers or oil fuel tanks.

**3.7.3.2.3** The arrangement of delivery ducts of the outside air foam system/foam generators of the inside air foam system shall in general be designed based on the approval test results in compliance with 3.7.3.1.1. A minimum of two generators/ducts shall be installed in every space containing combustion engines, boilers, purifiers, and similar equipment.

Small workshops (working spaces) and similar spaces listed in 1.5.3.2.2 and 1.5.8.1, may be covered with only one foam generator/foam delivery duct.

**3.7.3.2.4** Foam delivery ducts of the outside air foam system/foam generators of the inside air foam system shall be uniformly distributed under the uppermost ceiling in the protected spaces including the engine casing.

The number and location of foam generators shall be adequate to ensure all high fire risk areas are protected in all parts and at all levels of the spaces. Extra foam delivery ducts/foam generators may be required in obstructed locations.

The foam delivery ducts/foam generators shall be arranged with at least 1 m free space in front of the foam outlets, unless tested with less clearance.

The foam delivery ducts/foam generators shall be located behind main structures, and above and away from engines and boilers in positions where damage from an explosion is unlikely.

**3.7.3.2.5** The arrangement of the foam delivery ducts of the outside air foam system shall be such that a fire in the protected space will not affect the foam-generating equipment. If the foam generators are located adjacent to the protected space, foam delivery ducts shall be installed to allow at least 450 mm of separation between the generators and the protected space, and the separating divisions shall be class "A-60" rated.

**3.7.3.2.6** Foam delivery ducts shall be constructed of steel having a thickness of not less than 5 mm. In addition, stainless steel dampers (single or multi-bladed) with a thickness of not less than 3 mm shall be installed at the openings in the boundary bulkheads or decks between the foam generators and the protected space. The dampers shall be automatically operated (electrically, pneumatically or hydraulically) by means of remote control of the foam generator related to them.

The dampers shall be arranged to remain closed until the foam generators begin operating.

### **3.7.3.3 Systems for the protection of vehicle, ro-ro, special category and cargo spaces.**

**3.7.3.3.1** The system shall be supplied by the ship's main power source.

**3.7.3.3.2** Sufficient foam-generating capacity shall be provided to ensure the minimum design filling rate for the system, determined during approval testing in accordance with 3.7.3.1.1, is met and in addition shall be adequate to completely fill the largest protected space within 10 min. However, for systems protecting vehicle and ro-ro spaces and special category spaces, with decks that are reasonably gas-tight and that have a deck height of 3 m or less, the filling rate shall be not less than two thirds of the design filling rate determined during approval testing in accordance with 3.7.3.1.1 and in addition sufficient to fill the largest protected space within 10 min.

**3.7.3.3.3** The system may be divided into sections. However, the capacity and design of the system shall be based on the protected space demanding the greatest volume of foam. Adjacent protected spaces need not be served simultaneously if the boundaries between the spaces are "A" class divisions.

**3.7.3.3.4** A minimum of two foam delivery ducts of the outside air foam system/foam generators of the inside air foam system shall be installed in every space. The arrangement of foam delivery ducts/foam generators shall in general be designed based on the approval test results and be arranged to uniformly distribute foam in the protected spaces, and the layout shall take into consideration obstructions that can be expected when cargo is loaded on board. As a minimum, ducts/generators shall be led to/located on every second deck, including movable decks. The horizontal spacing of the ducts/generators shall ensure rapid supply of foam to all parts of the protected space. This shall be established on the basis of full scale tests.

**3.7.3.3.5** The foam delivery ducts/foam generators shall be arranged with at least 1 m free space in front of the foam outlets, unless tested with less clearance.

**3.7.3.3.6** The design and arrangement of outside air foam fire extinguishing systems shall be in compliance with 3.7.3.2.5 and 3.7.3.2.6.

### **3.7.3.4 Systems using outside air with generators installed inside the protected space.**

**3.7.3.4.1** To protect spaces specified in 3.7.3.2 and 3.7.3.3, the fixed high expansion foam fire extinguishing systems with foam generators using outside air but with generators located inside the protected

space and supplied by fresh air ducts may be applied. Such systems shall be equivalent to the outside air foam systems.

**3.7.3.4.2** For acceptance, the following minimum design features shall be considered:

- .1 lower and upper acceptable air pressure and flow rate in supply ducts;
- .2 function and reliability of damper arrangements;
- .3 arrangements and distribution of air delivery ducts including foam outlets; and
- .4 separation of air delivery ducts from the protected space.

### **3.8 CARBON DIOXIDE SMOTHERING SYSTEM**

#### **3.8.1 General.**

3.8.1.1 The amount of carbon dioxide, in kg, shall be determined by the formula

$$G=1,79V\varphi \quad (3.8.1.1)$$

where  $V$  - rated volume of the protected space (refer to **3.1.2.2**, **3.1.2.5**), in  $m^3$ ;

$\varphi$  - factor equal to:

0,3 for dry cargo holds and other spaces, except those indicated below;

0,35 for machinery spaces, the rated volume of which is determined with regard to the full volume of casings;

0,4 for machinery spaces, the rated volume of which is determined without any regard to the volume of casings from the level at which the horizontal area of the casings is equal to, or less than, 40 % of the horizontal cross-sectional area of the space itself measured in the middle between the floor covering of the inner bottom and the trunk bottom and storerooms specified in **1.5.3.2.2** (refer also to Footnote 3 to Table 3.1.2.1);

0,45 for vehicles spaces and ro-ro spaces which are not special category spaces and are capable of being sealed, and for which at least two thirds of the gas required for the relevant space shall be introduced within 10 min.

For machinery spaces such value of the factor  $\varphi$  shall be taken which results in a greater value  $G$ .

In ships of less than 2000 gross tonnage, except for passenger ships, factors 0,35 and 0,4 may be reduced to 0,3 and 0,35, respectively, if two or more machinery spaces, which are not fully separated from each other, are considered as forming one space.

**3.8.1.2** Where a carbon dioxide smothering piping is used as a smoke detection one, the carbon dioxide distributing manifold may be placed together with the CO<sub>2</sub> release controls for each space protected by the smoke detection system near its detecting units. However, it is recommended that the provision of such manifold shall not preclude the possibility of discharging CO<sub>2</sub> into any of the protected spaces directly from the fire extinction station, if two or more machinery spaces, which are not fully separated from each other, are considered as forming one space.

**3.8.1.3** The total cross-sectional area of manifolds and the cross-section of the distributing manifold shall be not more than the sum of the cross-sections of the cylinder valves simultaneously opening for the largest by volume protected space (for high-pressure systems) and not more than the cross-section of the tank discharge valve (for low-pressure systems).

**3.8.1.4** The cross-sections of distributing pipes for individual protected spaces shall be not more than the sum of the cross-sections of cylinder discharge valves simultaneously opening for the space concerned (for high-pressure system) or not more than the cross-section of the tank discharge valve (for low-pressure systems). The sum of the cross-sections of the discharge pipes shall not exceed the cross-section of the supply pipe except where the calculated pressure drop in any pipe cross section is not less than 1 MPa.

**3.8.1.5** The supply shall be ensured for:

- .1 machinery spaces - 85 % of the rated amount of carbon dioxide within not more than 2 min;
- .2 container and general cargo spaces (primarily intended to carry a variety of cargoes separately secured or packed) as well as for spaces specified in **1.5.4.3.1** and **1.5.4.4.1**, at least two thirds of the gas shall be discharged into the space within 10 min
- .3 solid bulk cargo spaces, at least two thirds of the gas shall be discharged into the space within 20 min.

The system controls shall be arranged to allow one third, two thirds or the entire quantity of gas to be discharged based on the loading condition of the hold.

**3.8.1.6** The thickness of pipe walls shall be calculated in accordance with **2.3**, Part VIII "Systems and Piping"; in this case, the design pressure  $p$  is assumed as equal to the design pressure of cylinders and tankers according to **3.8.2.1** and **3.8.3.1** and shall be not less than the values specified in Table 2.3.8 of the above Part.

**3.8.1.7** Carbon dioxide shall be supplied to the protected spaces through nozzles arranged in the upper part of these spaces. The piping for the distribution of fire extinguishing medium shall be arranged and discharge nozzles so positioned that a uniform distribution of carbon dioxide is obtained. Where the floor

plates of the machinery spaces of category A are placed higher than one metre above the tank top, a number of nozzles (about 15% of the total number) shall be fitted in the upper portion of the space below the plates.

**3.8.1.8** The total sectional area of the outlets of the nozzles of the space concerned shall not exceed 85 % of the total cross-section of the distributing piping.

**3.8.1.9** Perforated pipes may be used instead of nozzles in silencers, exhaust-gas boilers and smoke stacks. The total area of pipe perforations shall be by 10 % less than the pipe cross-section.

**3.8.1.10** In addition to the alarms required by **4.3.4**, signal whistles operated by the released carbon dioxide pressure shall be fitted on pipes laid in the spaces listed in **4.3.1**.

**3.8.1.11** The sealing materials for the valves and flexible hoses shall be usable at low temperatures down to 760°C.

**3.8.1.12** In piping sections where valve arrangements introduce sections of closed piping, such sections shall be fitted with a pressure relief valve and the outlet of the valve shall be led to open deck.

**3.8.1.13** All discharge piping, pipe fittings and nozzles in the protected spaces shall be constructed of materials having a melting temperature which exceeds 925°C. The piping and associated equipment shall be adequately supported.

**3.8.1.14** A fitting shall be installed in the discharge piping to permit the air testing.

### **3.8.2 High-pressure system.**

**3.8.2.1** The number of cylinders for storing liquid carbon dioxide shall be provided depending on the filling ratio (amount of carbon dioxide per 1 litre of cylinder capacity) which is not to be more than 0,675 kg/l at the design cylinder pressure 12,5 MPa and over and not more than 0,75 kg/l at the cylinder design pressure 15 MPa and over.

When filling cylinders, deviation of not more than by  $\pm 0,5$  kg from the rated amount per cylinder is permitted.

In cases specified in 3.1.3.3 and 3.8.5 the filling ratio shall be reduced by 0,075 kg/l against the above values.

**3.8.2.2** The cylinders shall be placed vertically in rows on the pads which may be made of wood and shall be accessible for inspection and checking of the amount of carbon dioxide contained therein. Each cylinder shall be marked with its ordinal number. Pilot cylinders shall be coated with a distinguished paint and be fitted in the fire extinction station. Pilot cylinders (carbon dioxide of at least 7 kg, compressed air or nitrogen) used for remote release may be placed at the fire stations or in the enclosures of the ship's internal spaces.

**3.8.2.3** A pipe connecting a cylinder with a manifold shall be as a rule seamless and made of red copper. But use of special flexible hoses made of approved materials is permitted.

A non-return valve shall be fitted on the pipe connecting the cylinder and the manifold.

Arrangement of the manifolds shall provide their complete draining.

**3.8.2.4** A manifold of the carbon dioxide extinction station shall be fitted with a pressure gauge graduated to a value at least 1 MPa in excess of the hydraulic test pressure of the carbon dioxide cylinders.

The value of the pressure gauge scale division shall not exceed 0,5 MPa.

**3.8.2.5** A carbon dioxide extinction station shall have arrangements for weighing the cylinders or measuring the level of liquid therein.

### **3.8.2.6 Valves of cylinders.**

**3.8.2.6.1** The valve shall have protective devices complying with the following requirements:

protective diaphragms shall break at a pressure rise in the cylinders up to  $(1,3 \pm 0,1)p$ , in MPa (where  $p$  is design pressure of the cylinder). For valves with slotted diaphragms which are additionally fitted with protective diaphragms the breaking pressure of slotted diaphragms shall be at least 1 MPa more than the highest value of the protective diaphragm breaking pressure;

there shall be provided a checking device to indicate that the protective device has operated.

**3.8.2.6.2** Where the lever type device is used to open the valve this device shall ensure the full opening of the valve by turning the lever to an angle not more than 90° and shall permit the valves to be opened individually or by groups.

**3.8.2.6.3** The cylinder valves shall be fitted with scarfed pipes cut short at 5 to 15 mm from the cylinder bottom; the inside diameter of the said valve pipes and of the pipes connecting the cylinder valves with a manifold shall be not less than 10 mm.

**3.8.2.6.4** If the design of the valves of pilot cylinders differs from that of the valves of all other cylinders, they shall be coated with a paint of another colour and have the inscription "starting".

**3.8.2.7** The gas from the protective devices of cylinders shall be discharged:



.1 to the atmosphere beyond the boundaries of the station through a separate pipe provided with an audible alarm at the outlet;

.2 to the distribution manifold where provision shall be made for:

two pipes, one of which is open-ended and fitted with a shut-off valve, and the other is provided with a protective diaphragm;

a signalling device to indicate the presence of pressure in the manifold whose readings shall be transmitted to the space where watch keepers are present all the time.

In this case, a checking device to indicate that the protective device has operated is not required for the valves.

### **3.8.3 Low pressure system.**

**3.8.3.1** The rated amount of liquid carbon dioxide shall be stored in tank (tanks) at the working pressure of about 1,8 - 2,2 MPa which is ensured by maintaining a temperature of about -18°C.

The normal liquid charge in the container shall be limited to provide sufficient vapour space to allow for expansion of the liquid under the maximum storage temperatures than can be obtained corresponding to the setting of the pressure relief valves but shall not exceed 95 % of the volumetric capacity of the container.

**3.8.3.2** A tank shall be served by two self-contained refrigerating plants, each consisting of one compressor, a condenser and a cooling battery.

The refrigerating capacity and the automatic control of each unit shall be so as to maintain the required temperature under conditions of continuous operation during 24 h at sea temperatures up to 32°C and ambient air temperatures up to 45°C.

When one of the plants is rendered inoperative, the other shall be automatically brought into operation.

Cooling batteries shall be separate for each plant or common, but they shall consist of not less than two isolated sections, each having a surface designed for full output.

In other respects, a refrigerating plant shall meet the requirements of Part XII "Refrigerating Plants" for unclassified plants (except for 3.3, 3.4, 3.5 and 6.2.6), as well as those of 2.1.1, 2.3.11, 2.3.12 and 7.2.2 for classed plants.

The system control devices and the refrigerating plants shall be located within the same room where the pressure vessels are stored.

**3.8.3.3** A tank shall be fitted with:

branches with shut-off valves for filling the tank;

a discharge pipe;

a device for direct monitoring of liquid carbon dioxide level, mounted on the tank;

two relief valves with discharge pipes laid to the open air and arranged so as to provide disconnection of any of them with the remaining one connected with the container;

a pressure gauge;

high (not more than setting of the relief valve) and low (not less than 1,8 MPa) pressure;

lowest acceptable level alarm device.

The setting of each relief valve shall be at least 1,1 - 1,2 $p$ , and its throughput shall be such that pressure in the tank with the valve fully open may not exceed 1,35 $p$  (here  $p$  is working pressure in the tank, in MPa).

The value of the design pressure of the tank shall be assumed equal to the greatest lifting pressure of a relief valve.

**3.8.3.4** If fitted outside the tank, the level gauge pipe of the device for remote monitoring of the level of liquid shall be shut off with two valves (open throughout the period of operation) and provided with one control hydrant only, nominally filled (100 %). The pipe and the control hydrant shall be thermally insulated.

**3.8.3.5** If the system serves more than one space, means for control of discharge quantities of CO<sub>2</sub> shall be provided, e.g. automatic timer or accurate level indicators located at the control position(s).

It shall be also possible to regulate the discharge manually.

**3.8.3.6** The tank and pipes led therefrom and permanently filled with carbon dioxide shall be provided with heat insulation preventing operation of the relief valve within 24 h after the installation is de-energized, at the ambient temperature of 45°C and initial pressure equal to the starting pressure of the refrigerating plant.

**3.8.3.7** Material for a tank shall meet the requirements of 3.3, Part XIII "Materials". Welds shall be radiographed as required for class II in Table 3.3.2-2, Part XIV "Welding".

**3.8.3.8** Safety relief devices shall be provided in each section of pipe that may be isolated by block valves and in which there could be a build-up of pressure in excess of the design pressure of any of the components.

**3.8.3.9** The alarm system shall give visual and audible alarm signals:

when the maximum (not higher than the setting of the relief valve) and minimum (not less than 18 bar) pressure is reached in the tank;

when the level of liquid carbon dioxide in the tank is reduced to the minimum acceptable level;

in case of refrigerating plant failure;

when the discharge of carbon dioxide begins.

The alarm signals shall be given at the central control station and in engineers' cabins.

### **3.8.4 Release control.**

**3.8.4.1** Controls of systems protecting those spaces, which are normally manned (refer to **4.3.1**), shall comply with the requirements of **3.8.4.2**.

**3.8.4.2** Two separate controls shall be provided for releasing carbon dioxide into a protected space and to ensure the activation of the alarm. One control shall be used for opening the valve of the piping which conveys the gas into the protected space and a second control shall be used to discharge the gas from its storage containers. Positive means shall be provided so that they can only be operated in that order. The two controls shall be located inside a release box clearly identified for the particular space. If the box containing the controls is to be locked, a key to the box shall be in a break-glass-type enclosure conspicuously located adjacent to the box.

**3.8.4.3** The pipe supplying gas from pilot cylinder to the pneumatic actuator of main bottles through a time-delay device shall be fitted with by-pass valve located across this time-delay device which can be used in case the device goes defective.

**3.8.4.4** In low pressure systems, release of carbon dioxide shall be manual. Where an automatic control system is provided to supply rated amount of carbon dioxide to protected spaces, manual regulation of gas supply shall also be provided.

Where the system serves more than one spaces, facilities shall be provided to control the amount of released carbon dioxide such as an automatic flowmeter or a precision level indicator located at the control station(s).

### **3.8.5 Local carbon dioxide fire extinction stations.**

In well-founded cases local stations with not more than five cylinders (not more than 125 kg of carbon dioxide) may be permitted for certain protected spaces.

In a machinery space carbon dioxide cylinders may be placed for fire protection of crankcases and silencers of internal combustion engines, of smoke stacks and other enclosed compartments.

## **3.9 EQUIVALENT FIRE EXTINGUISHING SYSTEMS FOR MACHINERY SPACES AND CARGO PUMP ROOMS MENTIONED IN 1.5.7.1**

**3.9.1** Fixed gas fire extinguishing systems equivalent to carbon dioxide smothering systems shall be of an approved type complying with the provisions of IMO circular MSC/Circ.848 "Revised Guidelines for the Approval of Equivalent Fixed Gas Fire-Extinguishing Systems, as Referred to in SOLAS-74, for Machinery Spaces and Cargo Pump Rooms", considering the amendments introduced by IMO circular MSC.1/Circ.1267.

**3.9.2** Fixed water-mist fire extinguishing systems shall be of an approved type complying with the provisions of IMO circular MSC/Circ.1165 "Revised Guidelines for the Approval of Equivalent Water-Based Fire-Extinguishing Systems for Machinery Spaces and Cargo Pump-Rooms", considering the amendments introduced by IMO circulars MSC.1/Circ.1269, MSC.1/Circ.1385 and MSC.1/Circ.1386.

## **3.10 DRY POWDER SYSTEM**

### **3.10.1 General.**

**3.10.1.1** An extinguishing powder approved by the Register for this purpose shall be used in the dry powder system.

**3.10.1.2** Nitrogen or other inert gas approved by the Register for this purpose shall be used as a propellant gas.

**3.10.1.3** The system shall consist of:

powder installations that contain dry powder containers, propellant gas cylinders and a distribution manifold;

hose stations;

pipes and fittings for bringing the system into action and powder supply to the hose stations.

**3.10.1.4** Provision shall be made for a remote release of the system from any hose station.

### **3.10.2 Quantity of dry powder and propellant gas. Capacity and number of nozzles.**

**3.10.2.1** A rated quantity of dry powder shall be stored in each container of the powder installation to provide a minimum 45 continuous discharge time at rated consumption for all attached monitors and hand hose lines.

**3.10.2.2** Each nozzle shall be capable of discharge at a rate not less than 3,5 kg/s, the powder throw range being not less than 8 m. In determining a maximum distance of coverage of each hand hose line the length of its hose shall be taken into account.

The capacity of each fixed monitor shall be at least 10 kg/s, maximum distance of coverage for monitors having a capacity 10, 25 and 45 kg/s shall be 10, 30 and 40 m, respectively.

**3.10.2.3** The number of hand hose lines and monitors shall provide the delivery of the dry chemical powder to any part of the cargo tank deck and cargo piping from two hand hose lines or a combination monitor/hand hose line.

At least one hand hose line or monitor shall be located aft of the cargo area.

**3.10.2.4** In gas carriers one monitor shall be provided in the cargo area to protect cargo manifold and capable of discharge locally and remotely.

**3.10.2.5** Dry powder fire extinguishing system for the protection of spaces stipulated in **1.5.3.2.2**, shall ensure the delivery of not less than 0,5 kg powder/m<sup>3</sup> for not more than 10 s.

**3.10.2.6** The quantity of the propellant gas shall provide for a single entire release of the dry powder from the powder container.

### **3.10.3 Powder fire extinction stations.**

**3.10.3.1** The powder fire extinction stations shall be positioned on the deck in the cargo area.

**3.10.3.2** The dry powder system shall consist of at least two self-contained station and in gas carriers with a cargo capacity of less than 1000 m<sup>3</sup> only one such station may be fitted.

**3.10.3.3** Ships fitted with bow or stern cargo loading and discharge manifold shall be provided with an additional dry powder fire extinction station complete with at least one monitor and one hand hose line.

**3.10.3.4** Where a fire extinction station has two or more hose stations, an independent pipe with release valves shall ensure proper dry powder delivery from the manifold to each station.

The powder fire extinction station shall provide for independent and simultaneous operation of all those stations.

### **3.10.4 Hose station.**

**3.10.4.1** Each hose station shall consist of remote-release cylinders with a non-kinkable hand hose line not more than 33 m in length or of a monitor.

**3.10.4.2** All hose station equipment, other than a monitor, shall be stored in a watertight box or cabinet.

**3.10.4.3** Each nozzle shall be fitted with an on/off operation and discharge device.

**3.10.4.4** The cross-section of the nozzle shall be equal to that of the fire hose line or less than that by not more than 50 %.

**3.10.4.5** Release cylinders shall be provided with pressure gauges.

**3.10.4.6** Instructions on putting the system into action shall be available at the hose station.

### **3.10.5 Dry powder containers, pipes and fittings.**

**3.10.5.1** Provision shall be made in the container for a dry powder discharge pipe cut short at about 100 mm from the bottom.

**3.10.5.2** A device shall be provided in the lower part of the container for gas flow into the container preventing the powder from flowing back into the gas pipe.

**3.10.5.3** The filling ratio of the containers shall be taken equal to not more than 0,95.

**3.10.5.4** Pipes and fittings shall have no contractions and abrupt expansions of cross-section.

**3.10.5.5** The cross-sectional area of the manifold in the powder installation shall be not less than the total area of the pipes connected thereto for simultaneous discharge of dry powder or shall be not more than twice that area.

**3.10.5.6** Provision shall be made on the distribution manifold for an arrangement for purging the pipes after use.

**3.10.5.7** A bending radius of the dry powder pipe shall be not less than 10 pipe diameters.

**3.10.5.8** The dry powder shall be discharged into the spaces indicated in **1.5.3.2.2** through nozzles. Their construction, arrangement and number shall provide for uniform spraying of powder in the entire volume of the space. The pressure at the remotest nozzle shall be taken at least equal to a minimum pressure necessary for effective spraying of powder.

## **3.11 AEROSOL FIRE EXTINGUISHING SYSTEM<sup>9</sup>**

### **3.11.1 General.**

**3.11.1.1** The fire extinguishing aerosol (which is produced while combustion of solid fuel aerosol generating compounds) generators used in the aerosol fire extinguishing systems shall be of the type approved by the Register.

**3.11.1.2** The aerosol fire extinguishing system shall include:

generators of fire extinguishing aerosol;  
remote control device;  
predischARGE alarms;  
cables.

**3.11.1.3** Design mass of the aerosol generating agent, in kg, shall be calculated for each protected space separately and shall be determined by the formula

$$G = (V + \sum_{j=1}^n V_{arj} \cdot P_{arj} \cdot P_a^{-1}) \cdot k \cdot q \quad (3.11.1.3)$$

where  $V$  - design (net) volume of the protected space, in  $m^3$ ;

$V_{arj}$  - volume of the  $j$ -th air receiver, in  $m^3$ , refer to **3.1.2.5**;

$n$  - number of air receivers in the protected space;

$j$  - serial number of air receiver;

$P_{arj}$  - working pressure in the  $j$ -th air receiver, in MPa;

$P_a$  - atmospheric pressure, in MPa;

$q$  - normative fire extinguishing concentration of aerosol, in  $kg/m^3$ ;

$k$  - factor of safety equal to 1,5.

**3.11.1.4** Normative fire extinguishing concentration of aerosol depends on the type of generator and usually does not exceed 0,2  $kg/m^3$ .

**3.11.1.5** At system actuation within the protected space, the following measures shall be taken:

automatic activation of the fire warning system in compliance with the requirements of **4.3**;

automatic shutdown of ventilation;

automatic closing of ventilation fire dampers;

automatic shutdown of the electric drives of oil burner units of boilers and incinerators and other equipment capable to reduce the concentration of fire extinguishing aerosol.

**3.11.1.6** The system discharge time shall not exceed 2 min.

**3.11.1.7** Arrangement of generators in the protected space shall ensure equal distribution of fire extinguishing aerosol. If there are shadow zones formed by equipment and boundaries fire extinguishing aerosol shall be fed directly to the shadow zones.

**3.11.1.8** Generators shall be installed considering the distance to the thermal zone boundaries (refer to **3.11.2.2**) so that the minimum safe distance away from the generators along the aerosol jet to escape routes<sup>9</sup>Refer also to IMO circular MSC.1/Circ.1270 "Revised Guidelines for the Approval of Fixed Aerosol Fire-Extinguishing Systems Equivalent to Fixed Gas Fire-Extinguishing Systems, as Referred to in SOLAS 74, for Machinery Spaces". and other areas where personnel may be present is not less than the distance to the thermal zone boundary with a temperature of 75°C, and to combustible materials - not less than the distance to the thermal zone boundary with a temperature of 200°C.

**3.11.1.9** Aerosols shall have non-ozone depleting characteristics.

**3.11.2 Fire extinguishing aerosol generators.**

**3.11.2.1** Fire extinguishing aerosol generator consists of a casing, which contains an aerosol generating agent, ignitor, electrical connection, devices for mounting to the ship structures. Casing of the generator shall be fitted with the arrangement (nozzle) for the release of an aerosol.

**3.11.2.2** Each type of generator shall have information about the distance (along the aerosol jet) from its exit out of the generator to the end of the thermal zone with the temperature 75°C and 200°C.

**3.11.2.3** The number of fire extinguishing aerosol generators shall be calculated for each protected space separately.

Design number of generators, in pieces, shall be determined by the formula

$$N = G/m \quad (3.11.2.3)$$

where  $G$  - design mass of aerosol generating agent, in kg, in accordance with **3.11.1.3**;

$m$  - mass of a charge in one generator, in kg.

The number of generators in the protected space shall be such that in the event of damage to any one power release line or generator, the aerosol concentration shall be not less than normative fire extinguishing concentration of aerosol  $q$  (refer to **3.11.1.4**) provided for the selected type of generator having regard to **3.11.1.7**.

Where the estimated number of generators  $N = 1$ , their number is taken equal to 2, and when  $N = 2$  - equal to 3.

**3.11.2.4** Casing of generator, its foundation and details fastening it to the foundation shall be made of non-combustible materials.

**3.11.2.5** The generators shall be designed to prevent self-activation at a temperature below 250°C.

**3.11.3 The fire extinguishing remote control device.**

**3.11.3.1** The remote control device shall comply with Section 2, Part XI "Electrical Equipment".

**3.11.3.2** The remote control device shall enable distant starting of all generators protecting the space.

The start-up of generators by groups is permitted proceeding from their number and provided the requirement of **3.11.1.6** is met.

**3.11.3.3** If several spaces are protected by the remote control device, it shall enable divided start-up of generators in each space.

**3.11.3.4** There shall be two sources of electrical power - main and emergency - for the remote control device.

**3.11.3.5** The remote control device shall enable automatic monitoring of electric circuits essential for the release of the system with indication of a faulty circuit and also generation of a signal for checking the operability of devices announcing about starting, as well as the signal for checking the possibility of shutdown of ventilation and other devices specified in **3.11.1.5**.

**3.11.4 Local stations of the aerosol fire extinguishing.**

In justified cases, to protect separate spaces other than machinery spaces of category A and containing no essential equipment, the local stations of the aerosol fire extinguishing may be equipped with at least two generators and the starting controls located outside the protected space and near the entrance to that space (without remote control device).

Starting controls shall meet the requirements of Section 2, Part XI "Electrical Equipment" and ensure: ready starting of generators at all times;

verification of the integrity of electric circuits essential for starting the generator;

periodical checks of the aerosol fire extinguishing system operability by means of starting with the use of simulators;

short-circuit protection in each electric circuit essential for starting the generators.

In this case, the actuation of equipment listed in **3.11.1.5** is provided by the ship means.

**3.11.5 Cabling.**

**3.11.5.1** Cabling shall comply with the requirements of Section 16, Part XI "Electrical Equipment".

**3.11.5.2** Electric circuits connecting generators shall be duplicated and widely separated. Within the protected space, electric circuits essential for the release of the system shall be fire resistant according to IMO circular MSC.1/Circ.1270.

**3.12 FIXED LOCAL APPLICATION FIRE EXTINGUISHING SYSTEMS FOR USE IN MACHINERY SPACES**

**3.12.1** Fixed local application fire extinguishing systems shall be fitted on passenger ships of 500 gross tonnage and above and on cargo ships of 2000 gross tonnage and above. The provisions of this Chapter do not apply to fishing vessels.

**3.12.2** Machinery spaces of category A above 500 m<sup>3</sup> in volume shall, in addition to the fixed fire extinguishing system required in Table 3.1.2.1, be protected by an approved type of fixed water-based or equivalent local application fire extinguishing system complying with the requirements of IMO Revised Guidelines<sup>10</sup>. In the case of periodically unattended machinery spaces the fire extinguishing system shall have both automatic and manual release capabilities.

In the case of continuously manned machinery spaces the fire extinguishing system is only required to have a manual release capability.

Where automatic release is provided the availability of manual release is obligatory.

The manual release shall be located at easily accessible position inside and outside the protected space. The manual release inside the protected space shall not be liable to be cut off by a fire in the protected areas.

The automatic release shall be activated by fire detection system, indicating fire risk areas. Besides it shall be so designed as to prevent accidental release of the local application fire extinguishing system.

**3.12.3** Fixed local application fire extinguishing systems are to protect fire risk areas of the following machinery and equipment (without the necessity of engine shutdown, personnel evacuation, or sealing of the spaces):

- .1 internal combustion engines;
- .2 incinerators;
- .3 purifiers for heated fuel oil;
- .4 boiler fronts (where nozzles are fitted);
- .5 inert gas generators;

.6 fuel heaters.

In multi-engine installations, at least two sections shall be arranged.

**3.12.4** The activation of any local application fire extinguishing system shall give a visual and a distinct audible alarm in the protected space in the main machinery control room and in the wheelhouse.

The alarm, which may be monotone, shall indicate the specific system activated. The system alarm requirements, described within this paragraph are in addition to, and not in lieu of, the fire detection and fire alarm systems required elsewhere in this Part.

**3.12.5** Electrical equipment of the system and its release alarm shall comply with the requirements of 7.13, Part XI "Electrical Equipment".

**3.12.6** Nozzles onboard shall be located in the same positions as during their testing carried out according to the IMO Revised Guidelines.

### 3.13 TESTING OF FIRE EXTINGUISHING SYSTEMS

**3.13.1** Fire extinguishing systems shall be tested in compliance with Table 3.13.1.

**3.13.2** The operational testing of the systems shall be conducted in conformity with Register - approved programs to verify their serviceability, operation of starting controls, and where prototype ships are concerned, to confirm the stipulated time for the fire extinguishing medium discharge into the protected space.

On prototype ships, a test discharge of the rated amount of carbon dioxide into one of the protected spaces is required for high-pressure carbon dioxide systems.

The test discharge may be omitted if reasonable substantiations are submitted to the Register.

<sup>10</sup> Refer to IMO circular MSC.1/Circ.1387.

**Table 3.13.1**

Nos.	Systems and assemblies to be tested	Hydraulic test pressure	
		in shop	on board ship
<b>1</b>	<b>2</b>	<b>3</b>	<b>4</b>
1	Foam and water fire extinguishing systems (refer also to Section 21, Part VIII "Systems and Piping"):		
	.1 pipes	-	In action
	.2 pipes of sprinkler system	-	1p
2	Pipes of dry powder system	1,5p	1p (by air)
3	Carbon dioxide systems		
3.1	High-pressure systems:		
	.1 pipes from cylinders to release control valves; transit pipe lines passing through spaces (refer to <b>3.1.4.1.4</b> )	-	1,5p
	.2 pipes from release control valves to nozzles and pipes from safety devices	-	5 MPa
3.2	Low-pressure systems:		
	.1 pipes from tank to release control valves	-	1,5p
	.2 pipes from release control valves to nozzles and pipes from safety devices	-	1p
4	Pipes and scrubber of the inert gas system	-	1p (by air)
5	Pneumatic pipes	-	1,5p
6	Cylinders, containers and tanks:		
	.1 operating under pressure, including cylinders without valves	1,5p	-

	.2 operating without pressure	By filling up to the top of the air pipe	In assembly with system
	.3 cylinders with screwed-in valves	$1p$ (by air)	-
7	Fittings	$1,5p$ , but not less than $0,2$ MPa	-

Notes: 1.  $p$  is the maximum working pressure in the system, and for carbon dioxide  $p$  is a design pressure of a cylinder or a tank, in MPa.

2. Fittings in assembly shall be tested for the tightness of closing by a pressure of at least  $1,25p$ , the valves of carbon dioxide cylinders - by the highest breaking pressure of protective diaphragms according to **3.8.2.6.1**.

3. The systems shall be tested in assembly on board ship upon completion of all erection work.

4. Pipes specified in **3.1.1** and **3.2.1**, after being tested by a pressure of  $1,5p$ , may be tested on board by pressure of  $1p$ .

5. Pipes of the water fire main system in ships of 500 gross tonnage and upwards (refer to **3.2.5.1**) shall be tested by a pressure of at least  $1,0$  MPa.

## 4 FIRE DETECTION AND ALARM SYSTEMS

### 4.1 GENERAL

**4.1.1** All electrical equipment, devices, alerts and indicators, feeders and wiring of fire detection and alarm systems shall fully comply with the requirements of 7.5 and 7.6, Part XI "Electrical Equipment" of these Rules, the Code on Alerts and Indicators and the FSS Code as well as the requirements of the Directive of the European Parliament and of the Council<sup>11</sup>.

All fire detection and alarm equipment and systems shall be designed to withstand ambient temperature changes, vibration, humidity, shock, impact and corrosion normally encountered in ships.

**4.1.2** In passenger ships, the control panel shall be located in the onboard safety centre. An indicating unit that is capable of individually identifying each detector that has been activated or manually operated call point shall be located on the navigation bridge.

In cargo ships, the control panel shall be located on the navigation bridge or in the fire control station.

In cargo ships, an indicating unit shall be located on the navigation bridge if the control panel is located in the fire control station. A space in which a cargo control console is installed, but does not serve as a dedicated cargo control room (e.g. ship's office, machinery control room), shall be regarded as a cargo control room, and therefore be provided with an additional indicating unit.

Clear information shall be displayed on or adjacent to each indicating unit about the spaces covered and the location of the sections.

In cargo ships and on passenger cabin balconies, indicating units shall, as a minimum, denote the section in which a detector has activated or manually operated call point has operated. In addition, controls for remote closing of the fire doors and shutting down the ventilation fans shall be centralized at the continuously manned central control station.

The ventilation fans shall be capable of reactivation by the crew at the continuously manned control station.

In passenger ships built on or after 1 January 2018, in the event that the wheelhouse is not attended, the audible fire alarm shall be located at the place of watch under the constant supervision of the responsible crew member.

The control panels in the central control station shall be capable of indicating open or closed position of fire doors, on or off status of the detectors, alarm and fans.

**4.1.3** Fire detection and fire alarm system shall not be used for any other purpose, except for closing fire doors from the switchboard and other similar purposes (refer to **3.12.2**). Where fire doors are at the same time watertight doors (refer to **7.12**, Part III "Equipment, Arrangements and Outfit") they shall not be automatically closed upon operation of fire alarms.

Detectors and manual call points shall be connected to dedicated sections of the fire detection and fire alarm system. Other fire safety functions, such as alarm signals from the sprinkler valves, may be permitted in separate sections.

### 4.2 FIRE DETECTION AND FIRE ALARM SYSTEMS

#### 4.2.1 Fixed fire detection and fire alarm systems.

**4.2.1.1** The fixed fire detection and fire alarm system shall be installed to protect:

.1 accommodation and service spaces and control stations (refer to 4.2.1.2);

.2 Category A machinery spaces periodically unattended and Category A machinery spaces in which installation of automatic and remote control systems and equipment has been approved by the Register instead of continuous manning of the space and the main propulsion plant and associated machinery including main sources of power are provided to a variable degree with automatic or remote control and permanently under supervision of the watchkeeping staff at the control station;

.3 cargo spaces in which packaged dangerous goods are carried (refer to 7.2.7) as well as cargo spaces which are inaccessible, on passenger ships, except cases when the ship is engaged in voyages of so short duration, that application of this requirement will be unsuitable;

.4 spaces for carriage of vehicles, special category spaces and ro-ro spaces (refer to 4.2.1.3). The fire detection and fire alarm system shall not be installed on weather decks used for the carriage of vehicles with fuel in their tanks;

.5 cabin balconies of passenger ships, when furniture and furnishings on such balconies are not as defined in 2.1.1.9. A fixed fire detection and fire alarm system for cabin balconies shall comply with the requirements of the FSS Code and IMO circular MSC.1/Circ.1242;

.6 enclosed spaces with incinerators. Enclosed spaces located on the weather deck where the incinerators are located, combined spaces for incinerators/waste and any waste storage room;

.7 special electrical spaces.

Spaces having little fire risk, such as void spaces with no storage of combustibles, private bathrooms, public toilets, fire extinguishing medium storage rooms, cleaning gearlockers (in which flammable liquids are not stored), open deck spaces and enclosed promenades having little or no fire risk and that are naturally ventilated by permanent openings, need not be fitted with detectors and manual call points.

**4.2.1.2** When protecting accommodation and service spaces and control stations the following shall be provided:

<sup>11</sup>Directive 2009/45 / EC of the European Parliament and of the Council of 6 May 2009 on safety rules and standards for passenger ships, which entered into force on 15 July 2009 (revised version of amendments made by Commission Directives 2010/36 / EU and (EU) 2016/844 and Directive (EU) 2017/2108 of the European Parliament and of the Council).

.1 smoke detectors shall be installed in all stairways, corridors and escape routes within accommodation spaces as specified in 4.2.1.2.2 - 4.2.1.2.4. The smoke detectors on stairways shall be located at the top level of the stair and at every each second level beneath. Consideration shall be given to installation of special smoke detectors in ventilation ducts;

.2 in passenger ships carrying more than 36 passengers the fixed fire detection and fire alarm system shall be so installed and arranged as to detect the presence of smoke in service spaces, control stations and accommodation spaces including corridors, stairways and escape routes within accommodation spaces;

.2.1 the fixed fire detection and fire alarm system shall be capable of remotely identifying each detector individually.

Where the fixed fire detection and fire alarm system do not include means of remotely identifying each detector individually, no section covering more than one deck within accommodation spaces, service spaces and control stations shall normally be permitted except a section which covers an enclosed stairway;

.2.2 each cabin shall be provided with a fire detector. When the system is required to sound a local audible alarm within the cabins where the detectors are located, a means to silence the local audible alarms from the control panel shall not be permitted;

.2.3 a section of detectors and manually operated call points shall not be situated in more than one main vertical zone, except on cabin balconies;

.2.4 the entire main vertical zone containing atrium (i.e. public spaces including three or more weather decks) shall be protected over the entire area by the smoke detection system;

.3 in passenger ships carrying not more than 36 passengers, there shall be installed throughout each separate vertical or horizontal zone, in all accommodation and service spaces, and where the Register considers it necessary, in control stations, except spaces posing no substantial fire risk such as void spaces, sanitary spaces, etc. either:

.3.1 a fixed fire detection and fire alarm system so installed and arranged as to detect the presence of fire in such spaces and provide smoke detection in corridors, stairways and escape routes within accommodation spaces; or

.3.2 a fixed fire detection and fire alarm system so installed and arranged as to detect the presence of smoke in corridors, stairways and escape routes within the accommodation spaces if there is an automatic sprinkler system so arranged as to protect such spaces (refer to Table 3.1.2.1);



**.3.3** the fixed fire detection and fire alarm system shall be capable of remotely and individually identifying each detector and manually operated call point;

**.3.4** detectors fitted in cabins, when activated, shall also be capable of emitting, or cause to be emitted, an audible alarm within the space where they are located;

**.4** detectors may be operated by heat, smoke or other products of combustion, flame or any combination of these factors. Detectors operated by other factors may be considered by the Register, provided that they are no less sensitive than the above detectors.

When fire detectors are installed in freezers, drying rooms, saunas, parts of galleys used to heat food, laundries and other spaces where steam and fumes are produced, heat detectors may be used;

**.5** in cargo ships accommodation and service spaces depending on a protection method are protected by a fixed fire detection and fire alarm system and/or by an automatic sprinkler system and fire alarm and detection system as follows:

**.5.1** when *method IC* is used: a fixed fire detection and fire alarm system shall be so installed and arranged as to provide smoke detection in all corridors, stairways and escape routes within accommodation spaces;

**.5.2** when *method IIC* is used: a fixed fire detection and fire alarm system shall be so installed and arranged as to provide smoke detection in all corridors, stairways and escape routes within accommodation spaces. In addition, an automatic sprinkler system shall be so installed and arranged as to protect accommodation spaces, galleys and other service spaces (refer to Table 3.1.2.1);

**.5.3** when *method IIIC* is used: a fixed fire detection and fire alarm system shall be so installed and arranged as to detect the presence of fire in all accommodation and service spaces, providing smoke detection in corridors, stairways and escape routes within accommodation spaces, except spaces posing no substantial fire risk such as void spaces, sanitary spaces, etc. In addition, a fixed fire detection and fire alarm system shall be so installed and arranged as to provide smoke detection in all corridors, stairways and escape routes within accommodation spaces.

However there is no need to provide fixed fire detection and fire alarm system in service spaces built away from the accommodation block;

**.6** if the fixed fire detection and fire alarm system is required for protection of spaces other than spaces specified in **4.2.1.2.1**, at least one detector complying with the requirements of the FSS Code shall be installed in each such space;

**.7** no section will pass through a space twice. When this is not practical (e.g., for large public spaces), the part of the section which by necessity passes through the space for a second time shall be installed at the maximum possible distance from the other parts of the section;

**.8** a section of fire detectors which covers a ro-ro space shall not include a machinery space of category A.

**4.2.1.3** The fire detection and fire alarm system installed in spaces intended for the carriage of vehicles, special category spaces and in ro-ro spaces shall provide early detection of fire. The type of automatic detectors and arrangement thereof shall be determined with consideration of effect of ventilation and other appropriate factors. After installation, the system shall be tested under normal ventilation conditions to determine the average time of its responding. The fire detection and fire alarm system may not be fitted in special category spaces if an effective watching in the form of continuous fire watch is maintained in the spaces throughout the voyage.

**4.2.1.4** Detectors shall be located for optimum performance. Positions near beams and ventilation ducts or other positions where patterns of air flow could adversely affect performance and positions where impact or physical damage is likely shall be avoided.

Detectors which are located on the overhead shall be a minimum distance of 0,5 m away from bulkheads, except corridors, lockers and stairways. The maximum spacing of detectors shall be in accordance with Table 4.2.1.4.

**Table 4.2.1.4**

Type of detector	Maximum floor area per detector, in m <sup>2</sup>	Maximum distance apart between centres, in m	Maximum distance away from bulkheads, in m
Heat	37	9	4.5
Smoke	74	11	5.5

The Register may permit deviation from the requirements of Table 4.2.1.4 based upon characteristics obtained during tests and agreed with the Register.

Automatic detectors located under mobile decks / platforms in vehicle spaces, special category spaces and ro-ro spaces shall also comply with the applicable requirements of Table. 4.2.1.4.

When heat-pulse detectors are used in machinery spaces, the deck area served by one detector shall be 50 m<sup>2</sup>, and distance between centres shall be not more than 6 m.

**4.2.1.5** A sample extraction smoke detection system of a type approved by the Register and meeting the requirements of 4.2.1.6 may be provided in cargo spaces specified in 4.2.1.1.3 and 4.2.1.1.4, except spaces specified in 1.5.4.3.2, 1.5.4.4.2 and 1.5.9.

**4.2.1.6** A sample extraction smoke detection system shall consist of the following main components: smoke accumulators, sampling pipes, three-way valves, if the system is interconnected to a fixed gas fire extinguishing system, control panel, and shall meet the following requirements:

**.1** the system shall be capable of continuous operation at all times. Systems operating on a sequential scanning principle may be permitted on agreement with the Register provided that interval *I* between two scannings of the same space does not exceed 120 s and provides time *T* mentioned in **4.2.1.6.10**. With a 20 % allowance the interval *I* is determined by the formula

$$I=1,2 \times T \times N$$

where *N* - the number of scanning points;

**.2** the sampling pipe arrangements shall be such that the location of the fire can be readily identified;

**.3** the system shall be constructed and installed so as to prevent the leakage of any toxic or flammable substances or fire extinguishing media into any accommodation and service space, control station or machinery space, as well as to avoid the possibility of ignition of flammable gas-air mixture;

**.4** at least one smoke accumulator shall be located in every enclosed space for which smoke detection is required. However, where a space is designed to carry oil or refrigerated cargo, or other cargoes for which a smoke sampling system is required, means may be provided to isolate the smoke accumulators in such compartments on agreement with the Register.

In cargo holds where non-gastight "tween deck panels" (movable stowage platforms) are provided, smoke accumulators shall be located in both the upper and lower parts of the holds;

**.5** smoke accumulators shall be located for optimum performance and shall be spaced so that no part of the overhead deck area is more than 12 m measured horizontally from an accumulator.

Where systems are used in spaces which may be mechanically ventilated, the position of the smoke accumulators shall be considered having regard to the effects of ventilation.

At least one additional smoke accumulator shall be provided in the upper part of each exhaust ventilation duct. An adequate filtering system shall be fitted at the additional smoke accumulator to avoid dust contamination.

Smoke accumulators shall be positioned where impact or physical damage is unlikely to occur;

**.6** the number of smoke accumulators connected to each sampling pipe shall ensure compliance with the requirements of **4.2.1.7**;

**.7** smoke accumulators from more than one enclosed space shall not be connected to the same sampling point;

**.8** sampling pipes shall be self-draining and protected from impact or damage during cargo operations;

**.9** the sensing unit shall operate before the smoke density within the sensing chamber exceeds 6,65 % obscuration per metre;

**.10** at least two sample extraction fans, duplicating one another, shall be provided.

The fans shall be of sufficient capacity to operate with the normal conditions of ventilation in the protected area. The connected pipe size shall be determined with consideration of fan suction capacity and piping arrangement shall satisfy the requirements of **4.2.1.7**. The fans, depending on capacity and length of piping, shall provide time *T* of total system operation delay not more than 15 s. The fan suction capacity shall be adequate to ensure the response of the most remote area within the required time criteria in **4.2.1.7**;

**.11** the switchboard shall have means permitting observation of smoke in the individual sampling pipe;

**.12** means shall be provided to monitor the airflow through the sampling pipes so designed as to ensure equal quantities are extracted from each interconnected accumulator;

**.13** sampling pipes shall be a minimum of 12 mm inside diameter. Where the pipes are used in conjunction with fixed gas fire extinguishing systems, the minimum size of pipe shall be sufficient to permit the fire extinguishing medium to be discharged within the appropriate time;

**.14** sampling pipes shall be provided with arrangement for periodically purging with compressed air;

**.15** control panel shall be located on the navigation bridge, in the central control station or carbon dioxide extinction station. The indicating unit shall be located on the navigation bridge if the control panel is located in the central control station or carbon dioxide extinction station.

Clear information shall be displayed on or adjacent to the control panel and indicating units designating the spaces covered.

Provision shall be made for checking the control panel of the smoke detection system in accordance with the procedure agreed with the Register;

**.16** provision shall be made for testing for correct operation and restoring to normal surveillance without the renewal of any component;

**.17** detection of smoke or other products of combustion shall initiate visual and audible signals at the control panel and indicating units;

**.18** power supplies necessary for the system operation shall be monitored loss of power. The loss of power shall initiate a visual and audible fault signal at the control panel and navigation bridge which shall be distinct from a fire signal (refer also to **7.5.4**, Part XI "Electrical Equipment");

**.19** means to manually acknowledge all alarm and fault signals shall be provided at the control panel.

The audible alarm sounders on the control panel and indicating units may be manually silenced. The control panel shall clearly distinguish between normal, alarm, acknowledged alarm, fault and silenced conditions;

**.20** the system shall be arranged to automatically reset to the normal operating condition after alarm and fault conditions are cleared;

**.21** suitable instructions and component spares shall be provided for the testing, maintenance and repair of the system.

**4.2.1.7** After installation, the system shall be functionally tested using smoke generating machines or equivalent as a smoke source. An alarm shall be received at the control panel in not more than 180 s for vehicle decks, and not more than 300 s for container and general cargo holds, after smoke is introduced at

the most remote accumulator.

#### **4.2.2 Manual alarms.**

**4.2.2.1** Manual fire alarms shall be provided in the ships which in compliance with **4.2.1.1** are equipped with fixed fire detection and fire alarm system.

**4.2.2.2** Manually operated call points shall be installed to protect all accommodated spaces, service spaces and control stations, considering the requirements of **4.2.1.2.3.3**. A manually operated call point fitting is not required in an individual space within the accommodation spaces, service spaces and control stations. A manually operated call point shall be located at each exit (inside or outside) to the open deck from the corridor such that no part of the corridor is more than 20 m from a manually operated call point.

**4.2.2.3** Service spaces and control stations which have only one access, leading directly to the open deck, shall have a manually operated call point not more than 20 m from the exit (measured along the access route using the deck, stairs and/or corridors).

**4.2.2.3.1** A manually operated call point is not required to be installed for spaces having little fire risk, such as carbon dioxide rooms, nor at each exit from the navigation bridge, in cases where the control panel is located in the navigation bridge.

**4.2.2.4** In special category spaces the manual call points shall be installed so that no part of the space is more than 20 m from the call point and one call point shall be installed close to each exits from such spaces.

**4.2.2.5** All buttons of manual fire alarms shall be painted red and adequately illuminated both in normal and emergency conditions. The button shall be protected with glass.

**4.2.2.6** Any required fixed fire detection and fire alarm system with manually operated call points shall be capable of immediate operation at all times.

On special agreement, particular spaces may be disconnected during specific work. In this case, the means for disconnecting the detectors shall be designed to automatically restore the system to normal surveillance after a predetermined time.

#### **4.2.3 Protection of unattended machinery spaces.**

**4.2.3.1** Unattended machinery spaces of category A, as well as heated air ducts and main boiler uptakes, essential auxiliary boilers with a steam capacity over 3 t/h and boilers with thermal liquids (including exhaust gas boilers) in such spaces shall be provided with an automatic fire alarm and fire detection system (refer also to **2.2.4**, Part IX "Machinery").

### **4.3 FIRE WARNING ALARMS**

**4.3.1** Means shall be provided for automatically giving audible and visual warning of the release of fire-extinguishing medium into any ro-ro spaces, container holds equipped with integral reefer containers, spaces

accessible by doors or hatches, and other spaces in which personnel normally work or to which they have access.

Conventional cargo spaces and spaces with only a local release need not be provided with such an alarm.

**4.3.2** The audible alarms shall be located so as to be audible throughout the protected space with all machinery operating, and the alarms shall be distinguished from other audible alarms by adjustment of sound pressure or sound patterns.

**4.3.3** Fire warning alarm (the pre-discharge alarm) shall be automatically activated, when any starting control is actuated or when direct access thereto is provided (by opening the release cabinet door, switching off the interlocking, etc.). The alarm shall operate for the length of time needed to evacuate the space, but in no case less than 20 s before the fire-extinguishing medium is released.

**4.3.4** The signal shall be clear, distinct and readily audible in a noisy space, and shall be of a tone distinct from all other signals. In addition to the audible signal, there shall be a visible signal: "**Gas! Go away!**" and for the spaces protected by the aerosol fire extinguishing systems - "**Aerosol! Go away!**".

Simultaneously with the pre-discharge alarm before the entrance to the space protected by the fire extinguishing system, there shall be a visible signal: "**Gas! Go away!**", "**Aerosol! Go away!**", depending on the case.

**4.3.5** Audible alarm in the cargo pump room of oil tankers shall be:  
pneumatic, operated by dry and clean air; or  
electrically-operated, intrinsically safe; or  
electrically-operated, the electric actuating mechanism being located outside the pump room.

## 5 FIRE-FIGHTING OUTFIT, SPARE PARTS AND TOOLS

### 5.1 FIRE-FIGHTING OUTFIT

**5.1.1** Items of fire-fighting outfit shall comply with the FSS Code and be of approved type and ready for use at any time.

Fire-fighting outfit shall be located in a readily accessible place.

In passenger ships the location of fire-fighting outfit shall be marked by photoluminescent material or by lighting. Such photoluminescent markers or lighting shall meet the requirements of **8.5.5**, Part III "Equipment, Arrangements and Outfit" of these Rules and the FSS Code.

**5.1.2** Depending on the purpose and size of the ship the standards for supplying portable firefighting appliances, apparatus and consumable materials shall be in compliance with Table 5.1.2 of this Part. Items of outfit in addition to those specified in the Table 5.1.2, shall be provided on ships carrying dangerous goods in accordance with **7.2.10**, oil recovery ships according to **6.4.10**, ships with distinguishing marks **FF** and **FFWS** in the class notation according to **6.6.11** of this Part; ships equipped with helidecks with descriptive notations **HELIDECK**, **HELIDECK-F** or **HELIDECK-H** according to **6.1.1.3**,

ships designed to carry containers on or above the weather deck in compliance with **6.7** of this Part.

**5.1.3** The couplings of all portable items of outfit (fire hoses, fire hose nozzles, portable foam generators, etc.) shall be of the standard quick-acting type and size adopted for the given ship. Unless one hose and nozzle is provided for each hydrant in the ship, there shall be complete interchangeability of hose couplings and nozzles. All couplings and items of outfit shall be made of a material resistant to marine environment.

Items of fire-fighting outfit installed in the dangerous areas, rooms and spaces as well as on the open decks of oil tankers and oil recovery ships, gas carriers and chemical tankers shall be of type preventing spark formation.

Aluminium alloys may be used for hose couplings and nozzles except weather decks of oil tankers and chemical tankers.

**5.1.4** Fire hoses shall comply with the following requirements:

**.1** shall have a length not less than 10 m, but not more than:

**.1.1** 15 m in machinery spaces;

**.1.2** 20 m in spaces other than those specified in **5.1.4.1.1** and on weather decks;

**.1.3** 25 m on weather decks of ships with maximum breadth more than 30 m.

In any case the fire hose length shall be sufficient to deliver a jet of water to any of the spaces where their use may be required;

The length of fire hoses, if they do not comply with the requirements of **5.1.4.1.1** to **5.1.4.1.3** (as a standard length) shall ensure effective and unobstructed use in accordance with the requirements of **3.2.6.2**, as second (continuous non-standard length) hose), and compliance with the requirements of **5.1.4.3**;

**.2** they shall be made of approved materials resistant to wear and destruction by microorganisms (rotting);

**.3** fire hoses in assembly with nozzles shall be stowed at hydrants or on open places on reels or in baskets. On open decks they shall be kept in spray-proof ventilated lockers or enclosures. Stowage locations for fire hoses with nozzles (fire lockers and enclosures) shall be marked with fire control signs "FH" in red color.

**.4** in passenger ships, there shall be provided at least one fire hose for each of the hydrants and these hoses shall be used only for fire fighting or testing at fire drills and surveys.

Additionally, in inner spaces in passenger ships carrying more than 36 passengers fire hoses shall be connected to hydrants at all times;

**Table 5.1.2**

Nos.	Description of items of outfit	Number of items of outfit to be available in each ship
<b>1</b>	<b>2</b>	<b>3</b>
1	Fire hoses with couplings (refer to <b>5.1.4</b> ):	
	.1 for water	In accordance with the number of hydrants fitted on board ship
	.2 for foam solution	In accordance with the number of fire hydrants to which foam solution is supplied from fixed foam fire extinguishing system. If the size of the water hoses required by <b>1.1</b> is suitable for handling foam solution, such hoses may be taken into account to complete the number of hoses to be coupled to the hydrants fitted on the upper decks
2	Fire hose nozzles:	
	.1 dual-purpose nozzles for producing a compact and a sprayed jet (refer to <b>5.1.5</b> )	<b>.1</b> In accordance with the number of hydrants fitted on board ship <b>.2</b> 2 additional fire nozzles shall be provided on ships with helideck in accordance with <b>6.1.1.3.3</b> .
	.2 air-foam nozzles (refer to <b>5.1.6</b> )	In accordance with the number of hydrants where to foam solution is supplied from fixed foam fire extinguishing system, but not less than 4
	.3 foam extension pipes (refer to <b>5.1.7</b> )	In accordance with the number of air-foam nozzles for fire extinction in cargo tanks of oil tankers
	.4 portable foam generators or portable combination-foam production units (refer to <b>5.1.19</b> )	Twice the rated number of foam generators
	.5 extension pipes (refer to <b>5.1.7</b> )	50 % of the number of portable foam generators or combination-foam production units intended for fire extinction in the cargo tanks of oil tankers
3	Portable foam applicator (refer to <b>5.1.8</b> )	<b>1</b> In machinery spaces at least one set in spaces containing internal combustion engines and one set in each boiler room or externally close to the entrance to the boiler room <b>2</b> In each fuel distributing station and each cargo hose room, 1 set <b>3</b> In working spaces referred to in <b>1.5.8.1</b> , 1 set per fire hydrant fitted, but not more than 3 sets are required for each space. A space of less than 150 m <sup>2</sup> need not have more than 1 set <b>4</b> In ships with spaces specified in <b>1.5.4.3</b> , <b>1.5.4.4</b> and <b>1.5.9</b> not less than two sets for use in these

		<p>spaces and additionally one set in each such space if vehicles with fuel in their tanks for self propulsion are carried therein.</p> <p>There is no need to provide sets for weather decks used for the carriage of vehicles with fuel in their tanks, as well as for cargo spaces used for the carriage of vehicles with fuel in their tanks which are loaded in open or closed containers</p> <p><b>5</b> On open deck of container ships, 2 sets</p>
4	<p>Portable foam fire extinguishers, dry powder fire extinguishers and carbon dioxide fire extinguishers (refer to <b>5.1.9</b>). The use of dry powder fire extinguishers is permitted in all spaces instead of foam and carbon dioxide fire extinguishers except for the spaces where the energized electrical and radio equipment is installed of over 1000 V</p> <p>Portable foam fire extinguishers, dry powder fire extinguishers and carbon dioxide fire extinguishers (refer to <b>5.1.9</b>). The use of dry powder fire extinguishers is permitted in all spaces instead of foam and carbon dioxide fire extinguishers except for the spaces where the energized electrical and radio equipment is installed of over 1000 V</p>	<p>Ships of gross tonnage 1000 and above shall have at least 5 portable fire extinguishers. The minimum number of fire extinguishers at control stations, accommodation and service spaces shall be determined on the basis of 2 fire extinguishers for every 25 m or part thereof, of the deck length on which such spaces are situated, but not less than the number required in accordance with the following provisions</p> <p><b>1 Control stations:</b></p> <p><b>1.1</b> 1 foam fire extinguisher for each space, 1 fire extinguisher being permitted to be fitted in the corridor for a group of small spaces with a total area of up to 50 m<sup>2</sup>, provided that the entrances to the spaces are adjacent and situated in the same corridor. One additional carbon dioxide fire extinguisher when main switchboards are arranged in the main machinery control room;</p> <p><b>1.2</b> 1 carbon dioxide fire extinguisher for each space or group of spaces (as specified in <b>4.1.1</b> of this Table) containing electrical or radio equipment, as also for chart compartments;</p> <p><b>1.3</b> 1 foam fire extinguisher for each space containing an emergency diesel-generator or a fire diesel-driven pump;</p> <p><b>1.4</b> two dry powder fire extinguishers in the wheelhouse. If the wheelhouse is less than 50 m<sup>2</sup>, only 1 fire extinguisher is required. If the wheelhouse is adjacent with the chartroom and has a door giving direct access to the chartroom, no additional fire extinguisher is required. The same applies to the safety centres if they are within the boundaries of the wheelhouse in passenger ships</p> <p><b>2 Accommodation and service spaces:</b></p> <p><b>2.1</b> for each full or partial 25 m of length of corridors within each deck and main vertical zone, 1 foam fire extinguisher;</p> <p><b>2.2</b> for each full or partial 250 m<sup>2</sup> of area of public spaces, 1 foam fire extinguisher. For spaces less than 15 m<sup>2</sup> in area fire extinguishers fitted near them may be used;</p> <p><b>2.3</b> in galleys and bakeries with oil-fired equipment, 1 foam fire extinguisher for each space. For galleys with deep-fat fryers, 1 additional fire extinguisher fit for extinguishing cooking grease, fat and oil;</p>

	<p>Portable foam fire extinguishers, dry powder fire extinguishers and carbon dioxide fire extinguishers (refer to 5.1.9). The use of dry powder fire extinguishers is permitted in all spaces instead of foam and carbon dioxide fire extinguishers except for the spaces where the energized electrical and radio equipment is installed of over 1000 V</p>	<p>2.4 in galleys and bakeries with electrical, steam, coal- or gas-fired equipment, having the area of more than 50 m<sup>2</sup>, 1 foam or carbon dioxide fire extinguisher;</p> <p>2.5 in other domestic service spaces, 1 foam fire extinguisher (where fire extinguishers are available in the corridor, at the entrance to the space, provision of fire extinguishers within the space is not compulsory);</p> <p>2.6 in each stairway enclosure and in each lobby, 1 foam fire extinguisher;</p> <p>2.7 in storerooms for readily flammable (refer also to 3.1.3.4) and combustible materials, 1 foam fire extinguisher for each space. Where the storeroom area is less than 50 m<sup>2</sup>, the fire extinguishers may be kept in the corridor in close vicinity of the entrance to the space concerned or group of small spaces (with a total area not more than 50 m<sup>2</sup>);</p> <p>2.8 in the hospital, 1 dry powder fire extinguisher</p> <p><b>3 In addition to the above number of fire extinguishers, within the other ship's spaces the number of fire extinguishers shall be determined as follows</b></p> <p>3.1 In machinery spaces containing internal combustion engines the portable foam fire extinguishers shall be located within 10 m from any point of the space. Each such space shall contain not less than 2 fire extinguishers</p> <p>3.2 In machinery spaces containing oil-fired boilers -two foam fire extinguishers nearby each boiler front. If oilfired units are located in this space - two additional foam fire extinguishers.</p> <p>3.3 In enclosed spaces with oil-fired inert gas generators, incinerators and waste disposal units, 2 foam fire extinguishers</p> <p>3.4 In machinery spaces containing steam turbines or enclosed steam engines the number of fire extinguishers is determined in accordance with 4.3.2. However, such fire extinguishers shall not be required in addition to those specified in 4.3.2</p> <p>3.5 In spaces containing electric machinery or equipment:</p> <p>3.5.1 1 carbon dioxide fire extinguisher, for spaces containing main internal combustion or steam machinery, if the total power of the main machinery is less than 740 kW;</p> <p>3.5.2 2 carbon dioxide fire extinguishers, for spaces containing main internal combustion or steam machinery, if the total power of the main machinery is equal to, or more than, 740 kW;</p> <p>1 carbon dioxide fire extinguisher for each electric generator or group of generators, the total power being 500 to 1000 kW;</p> <p>1 carbon dioxide fire extinguisher for each space or group (not more than three) of small spaces</p>
--	---	---

	<p>Portable foam fire extinguishers, dry powder fire extinguishers and carbon dioxide fire extinguishers (refer to <b>5.1.9</b>). The use of dry powder fire extinguishers is permitted in all spaces instead of foam and carbon dioxide fire extinguishers except for the spaces where the energized electrical and radio equipment is installed of over 1000 V</p>	<p>containing auxiliary machinery with electrical drives and for special electrical spaces.</p> <p>The carbon dioxide fire extinguishers required by this sub-item shall be provided in the above spaces whether or not provision is made for foam extinguishers required by other sub-items of this Table</p> <p><b>3.6<sup>4</sup></b> In separate spaces containing switchboards, 2 carbon dioxide fire extinguishers per space.</p> <p>In space having an area of 15 m<sup>2</sup>, 1 carbon dioxide fire extinguisher, near the entrance to the space</p> <p><b>3.7</b> At the entrance to accumulator battery rooms, other than those for radio stations and emergency lighting, 1 carbon dioxide fire extinguisher per space</p> <p><b>3.8</b> In compartments for auxiliary machinery, 1 foam fire extinguisher, when the space area is 50 m<sup>2</sup> and more, otherwise the fire extinguisher placed near the entrance to such space may be sufficient</p> <p><b>3.9</b> For oil fuel tanks, other than those of double bottom, not less than 2 foam fire extinguishers in each space adjacent to the walls or decks of the tanks. If such adjacent spaces are already provided with fire extinguishers, no additional fire extinguishers are required</p> <p><b>3.10</b> In cargo pump rooms, 2 foam fire extinguishers; in other pump rooms, fuel oil distribution stations, in the fuel pipe trunks, hose spaces, 1 foam fire extinguisher for each 30 m<sup>2</sup> of the space floor</p> <p><b>3.11</b> In working spaces, 2 foam fire extinguishers, if the space area is under 100 m<sup>2</sup>, plus 1 foam fire extinguisher for every 250 m<sup>2</sup> or part thereof, if the space area is more than 100 m<sup>2</sup></p> <p><b>3.12</b> In welding shops and in storerooms for welding equipment, 1 foam fire extinguisher and one carbon dioxide fire extinguisher per space</p> <p><b>3.13</b> In special category spaces, cargo spaces for motor vehicles with fuel in their tanks and in ro-ro cargo spaces on each deck, 1 fire extinguisher for each 20 m of deck length on both sides.</p> <p>At entrances to such spaces from accommodation and machinery spaces, 1 foam fire extinguisher.</p> <p>There is no need to provide additional fire extinguishers for weather decks used for the carriage of vehicles with fuel in their tanks, as well as for cargo spaces used for the carriage of vehicles with fuel in their tanks which are loaded in open or closed containers</p> <p><b>3.14</b> At each entrance in the periodically unattended machinery spaces of category A, 1 foam fire extinguisher</p> <p><b>3.15</b> In workshops forming part of machinery spaces, 1 dry powder fire extinguisher</p> <p><b>3.16</b> During carriage of dangerous goods on deck, 2 fire extinguishers each having a capacity of not less than 6 kg of dry powder or equivalent</p>
--	--	---



		<p><b>3.17</b> On the weather deck of tankers, 2 fire extinguishers each having weight of not more than 23 kg in the charged condition</p> <p><b>3.18</b> Additional fire extinguishers shall be provided on ships with helideck in accordance with <b>6.1.1.3.2</b>.</p>
5	<p>Foam fire extinguishers of at least 45 l capacity or at least 16 kg carbon dioxide or dry powder fire extinguishers (refer to <b>5.1.10</b> and <b>5.1.11</b>)</p> <p>The use of dry powder fire extinguishers is permitted in all spaces instead of foam and carbon dioxide fire extinguishers except for the spaces where the energized electrical and radio equipment is installed of over 1000 V</p>	<p><b>1</b> In machinery spaces containing internal combustion engines in number according to <b>5.1.10.4</b></p> <p><b>2</b> In machinery spaces containing steam turbines or enclosed steam engines in number according to <b>5.1.10.4</b>, however such fire extinguishers are not required if the space is protected by a fixed fire extinguishing system according to Table 3.1.2.1</p> <p><b>3</b> In the working spaces, referred to in <b>1.5.8.1</b> 1 fire extinguisher mentioned in <b>5.1.11</b> for every 300 m<sup>2</sup> or part thereof, of each working space (bounded by watertight and gastight bulkheads)</p> <p><b>4</b> In spaces containing electric generators or propulsion motors with the total power output being 1000 to 5000 kW, 1 fire extinguisher according to 5.1.11 for each space</p> <p><b>5</b> In separate spaces containing electric switchboards if the switchboard length is more than 5 m and the space is not protected by means of a fire smothering system, 1 fire extinguisher mentioned in <b>5.1.11</b> for a space</p> <p><b>6</b> In special electrical spaces with deck area 4m<sup>2</sup> and upwards 1 fire extinguisher in accordance with <b>5.1.11</b> per space</p> <p><b>7</b> Additional fire extinguishers shall be provided on ships with helideck in accordance with <b>6.1.1.3.2</b>.</p>
6	<p>Foam fire extinguishers, at least 136 l capacity, or at least 45 kg carbon dioxide fire extinguishers or dry powder fire extinguishers (refer to 5.1.10 and 5.1.11)</p> <p>The use of dry powder fire extinguishers is permitted in all spaces instead of foam and carbon dioxide fire extinguishers except for the spaces where the energized electrical and radio equipment is installed of over 1000 V</p>	<p><b>1</b> In machinery spaces containing oil fuel units as well as oil-fired boilers - one fire extinguisher per each space.</p> <p>In boiler rooms with domestic boilers of less than 175 kW and in case of boilers protected by fixed local application fire extinguishing systems, the fire extinguisher is not required</p> <p><b>2</b> In spaces containing electric generators and propulsion motors with the total power output 5000 kW and over, 1 fire extinguisher according to 5.1.11 for a space.</p> <p>Three fire extinguishers in accordance with item 5 of this Table may be used instead of one fire extinguisher prescribed by this item</p> <p><b>3</b> In special electrical spaces containing electrical equipment with the total power output 5000 kW and over, 1 fire extinguisher according to 5.1.11 for a space.</p> <p>Three fire extinguishers in accordance with item 5 of this Table may be used instead of one fire extinguisher prescribed by this item.</p>
7	<p>Metal receptacles containing sand or sawdust (refer to 5.1.12)</p>	<p>1 receptacle in each firing space in each boiler room with oil-fired boilers, and each space containing a part of the fuel oil unit, as well as near lamp and paint lockers, fuel filling and distributing positions and in</p>

		<p>other fire hazardous areas where fuel oil or other flammable liquids are liable to spread (except for machinery spaces).</p> <p>1 receptacle containing sand or dry sawdust impregnated with soda may be replaced by 1 portable foam fire extinguisher</p>
8	Blankets (refer to 5.1.13)	<p><b>1</b> 1 blanket for every 40 m, or part thereof, of open deck length of oil tankers and passenger ships</p> <p><b>2</b> In all other ships not referred to in 8.1 of this Table, 1 blanket, if the ship is up to 1000 gross tonnage, and 2 blankets, if the ship is of 1000 gross tonnage and upwards</p> <p><b>3</b> In machinery spaces of category A in ships of more than 500 gross tonnage, 1 blanket for each space</p> <p><b>4</b> In working spaces indicated in 1.5.8.1, 1 blanket for each space</p> <p><b>5</b> In ships with helidecks – in accordance with <b>6.1.1.3.5</b>.</p>
9	Sets of fire fighting tools (refer to <b>5.1.14</b> )	<p>For ships of less than 2000 gross tonnage, 1 set</p> <p>For ships of 2000 to 4000 gross tonnage, 2 sets</p> <p>For ships of 4000 to 10000 gross tonnage, 3 sets</p> <p>For ships of 10000 gross tonnage and upwards, 4 sets</p>
10	Fireman's outfit (refer to <b>5.1.15</b> )	<p><b>1</b><sup>3</sup> In passenger ships, 2 sets and additionally for every 80 m, or part thereof, of the total length of all accommodation and service spaces on the deck they are situated, or if there are more than one such deck on the deck with the maximum total length of the above spaces 2 sets in accordance with <b>5.1.15</b> and 2 sets of personal outfit in accordance with <b>5.1.15.1.1 - 5.1.15.1.3</b>. In passenger ships carrying more than 36 passengers, two additional fireman's outfits shall be provided for each main vertical zone. However, for stairway enclosures which constitute individual main vertical zones and for the main vertical zones in the fore or aft end of the ship, which do not contain spaces of categories (6), (7), (8) or (12) (refer to 2.2.1.3), no additional fireman's outfits are required.</p> <p><b>2</b> In oil tankers and combination carriers of 500 gross tonnage and upwards, 4 sets</p> <p><b>3</b> In cargo ships of 500 gross tonnage and upwards, 2 sets</p> <p><b>4</b> In ships equipped with helidecks additional equipment according to <b>6.1.1.3.4</b> shall be provided</p>
11	Portable electric or pneumatic drills (refer to <b>5.1.16</b> )	In all ships of 4000 gross tonnage and upwards, 1 drill per ship
12	Portable fire motor-pumps <sup>1</sup> complete with suction and delivery hoses and fire hose nozzles (refer to <b>5.1.17</b> and <b>8.7.2.5</b> )	<p>On the ships of less than 500 gross tonnage - in accordance with 8.7.2.1, 8.7.2.6</p> <p>As emergency fire pump (refer to <b>3.2.1.2</b>) – 1 per ship.</p>
13	International shore connection (refer to <b>5.1.18</b> )	In all ships of 500 gross tonnage and upwards, and on the floating cranes, 1 set
14	Foam concentrate	Full amount of foam concentrate required by 3.7
15	Gaz analyzers (refer to <b>5.1.22</b> ):	
	<b>.1</b> for vapours of flammable liquids and exhaust gases;	In ships carrying motor vehicles with fuel oil (other than diesel oil) in their tanks and in ships with spaces specified in <b>1.5.4.3</b> , <b>1.5.4.4.1</b> , <b>1.5.9 - 1</b>

	<b>.2</b> for vapours of flammable liquids;	In oil tankers and combination carriers - 1 (refer to <b>5.1.22</b> ) In oil tankers fitted with inert gas system - 1 portable gas analyzer capable to operate in the inert gas atmosphere in addition to the above
	<b>.3</b> for oxygen content;	In oil tankers and combination carriers - 1 (refer to <b>5.1.22</b> )
	<b>.4</b> for oxygen content and gas detection	In ships carrying solid bulk cargoes which are liable to emit toxic or flammable gases or cause oxygen depletion in the cargo space - 1
16	Fog applicator (refer to <b>5.1.20</b> )	<b>1</b> In passenger ships carrying more than 36 passengers: in each machinery space of category A, 2 pcs <b>2</b> In passenger ships carrying more than 36 passengers: for each pair of breathing apparatuses (refer to <b>5.1.15.2</b> ), 1 pc <b>3</b> In each space for the carriage of vehicles, ro-ro spaces and special category spaces intended for the carriage of vehicles with fuel in their tanks for self propulsion, 3 pcs. There is no need to provide applicators for weather decks used for the carriage of vehicles with fuel in their tanks as well as for cargo spaces used for the carriage of vehicles with fuel in their tanks which are loaded in open or closed containers
17	Fire buckets (refer to <b>5.1.21</b> )	In ships having no water fire main system, 3 buckets
18	Emergency Escape Breathing Devices (EEBD) (refer to 5.1.23)	<b>1</b> Within accommodation spaces: <b>.1.1</b> in cargo ships, 2 pcs; <b>.1.2</b> in passenger ships, 2 pcs in each main vertical zone. In passenger ships carrying more than 36 passengers, in addition to those required, two additional EEBD shall be provided in each main vertical zone. This requirement is not applied to stairway enclosures comprising separate main vertical zones and to main vertical zones at both ends of a ship which do not have spaces of categories (6), (7), (8) or (12) specified in <b>2.2.1.3</b> <b>2</b> In machinery spaces EEBD shall be located at easily visible places, which can be easily accessed in case of fire. The location of EEBD shall take into account the arrangement of the equipment and the number of persons usually manning the space: <b>.2.1</b> in machinery spaces of category A containing internal combustion engines used for main propulsion; <b>.2.1.1</b> in the main machinery control room, if located within the machinery space, 1 pc; <b>.2.1.2</b> in workshop area, 1 pc. If there is a direct exit from the workshops, not entering the engine room, an EEBD is not required; <b>.2.1.3</b> close to each ladder constituting the means of escape from machinery space (refer to <b>4.5.5.2</b> and <b>4.5.10.2</b> , Part VII "Machinery Installations"), 1 pc at each deck or platform;

		<p><b>.2.2</b> in machinery spaces of category A other than those specified in <b>18.2.1</b>, 1 pc, as a minimum, located in accordance with <b>18.2.1.3</b>;</p> <p><b>.2.3</b> in other machinery spaces, the necessity, number and location of EEBD shall be determined on agreement with the Register</p> <p><b>3</b> Provision shall be made for two spare EEBD for passenger ships and one spare EEBD for cargo ships</p> <p><b>4</b> Provision shall be made for at least one EEBD for training in every ship</p>
<p><sup>1</sup> In non-self-propelled oil tankers a portable manual pump with capacity of at least 6 m<sup>3</sup>/h with a nozzle with a diameter of 10 mm and a pressure at the shaft of at least 0.2 MPa shall be installed instead of a motor pump. The pump shall be fitted with two receiving hoses 4 m long with a non-return valve, two ejection hoses 20 m long and a manual nozzle of the combined type with a nozzle diameter of 10 mm.</p> <p><sup>2</sup> In passenger ships in accommodation and service spaces, the number of fire extinguishers and their location shall be such that the distance from any place to the fire extinguisher is not more than 10 m. Fire extinguishers shall, as far as practicable, have the same methods of application.</p> <p><sup>3</sup> In passenger ships of restricted navigation areas: B-R3-RSN, with length 24m and upwards, and on new C-R3-RSN and D-R3 ships, with length 40m and upwards, but less than 60m, - two fireman's outfits; B-R3-RSN, with length 24m and more, but less than 40m - two fireman's outfits, but there can be only one spare cylinder filled with compressed air for self-contained breathing apparatus; B-R3-RSN, less than 24 m long, and on C-R3-RSN and D-R3 ships, less than 40 m long - no fireman's outfit is required.</p> <p><sup>4</sup> Fire extinguishers designed for high voltage use shall be located near each electrical switchboard or panel with a power of 20 kW or over.</p>		

**.5** on cargo ships:

**.5.1** of 1000 and more gross tonnage, the number of fire hoses is determined one fire hose per each 30 m of length and one spare fire hose, but not less than five hoses per ship. This number doesn't include any hoses required for machinery or boiler spaces. The Register may require to increase number of hoses in order to ensure sufficient number of hoses and their accessibility at any time, considering the type of ship and character of voyages made by the ship. A ship carrying dangerous goods shall be equipped with three additional hoses and nozzles in excess of those required above;

**.5.2** of less than 1000 gross tonnage, the number of fire hoses is calculated in accordance with **5.1.4.5.1**. However, the number of hoses shall be not less than three.

**5.1.5** Standard nozzle sizes shall be 12, 16 and 19 mm or close thereto.

Nozzles sizes greater than 12 mm need not be used in accommodation, service and working spaces. In ships under 150 gross tonnage nozzles having 10 mm in diameter are permitted to be used. For machinery spaces and exterior locations, the nozzle size shall be such as to obtain maximum discharge possible from two jets at the pressure at each hydrant mentioned in Table 3.2.1.1 from the smallest pump, but nozzles sizes greater than 19 mm need not be used.

Nozzles shall be of an approved dual-purpose type with a shut-off device. Fire hose nozzles made of plastic type material, e.g. polycarbonate, are considered acceptable provided capacity and serviceability are documented and the nozzles are found suitable for the marine environment.

**5.1.6** Air-foam nozzles for delivery of low-expansion foam (refer to **3.7**) from fixed fire extinguishing system shall comply with the following requirements:

**.1** on cargo tank deck of oil tankers each nozzle shall be capable of delivering 400 l/min of foam, in this case, the length of jet delivered by the fire hose at still-air shall be not less than 15 m (refer also to **3.7.2.3**);

**.2** in ship's spaces each nozzle shall be capable of delivering at least 2 l/min of foam solution per square meter of deck area;

**.3** prototype tests of the monitors and foam applicators shall be performed to ensure the foam expansion and drainage time of the foam produced does not differ more than ±10 % of that determined in **3.7.1.2**.

**5.1.7** Foam extension pipes with a hook-shaped bell-mouth at the end (for low-expansion foam) and extension pipes fitted with light supports at the middle (for medium-expansion foam) shall be of about 4 m in length.

An extended air-foam nozzle having a hook-shaped bell-mouth may be used in addition to the usual air-foam nozzle instead of a foam extension pipe.

#### **5.1.8 Portable foam applicator unit.**

**5.1.8.1** A portable foam applicator unit shall consist of a foam nozzle/branch pipe, either of a self-inducing type or in combination with a separate inductor, capable of being connected to the fire main by a fire hose, together with a portable tank containing at least 20 l of foam concentrate and at least one spare tank of foam concentrate of the same capacity.

**5.1.8.2** The nozzle/branch pipe and inductor shall be capable of producing effective foam suitable for extinguishing an oil fire, at a foam solution supply rate of at least 200 l/min at the nominal pressure in the fire main.

**5.1.8.3** The foam concentrate shall be approved by the Register based on IMO circular MSC.1/Circ.1312.

**5.1.8.4** The values of the foam expansion and drainage time of the foam produced by the portable foam applicator unit shall not differ more than  $\pm 10\%$  of that determined in IMO circular MSC.1/Circ.1312.

**5.1.8.5** The portable foam applicator unit shall be designed to withstand clogging, ambient temperature changes, vibration, humidity, shock, impact and corrosion normally encountered on ships.

**5.1.8.6** The portable foam applicator units shall be located near hydrants.

**5.1.9** Portable fire extinguishers shall be of type and design approved by the Register taking into account the IMO Guidelines (refer to IMO resolution A.951(23)) and shall comply with the following requirements:

**.1** no fire extinguishing medium shall be used which, either by itself or under anticipated conditions of application, would give off toxic gases in amounts dangerous to human health;

**.2** fire extinguishers shall have safety devices preventing the pressure therein to rise above permissible limits;

**.3** for 100 % of the first ten fire extinguishers and 50 % of the remaining fire extinguishers capable of being recharged onboard shall be provided with spare chargers. No more than 60 pieces of spare charges of the total number of fire extinguishers are required;

**.4** for fire extinguishers which cannot be recharged onboard, additional portable fire extinguishers of the same quantity, type, capacity and number, as determined in **5.1.9.3** above, shall be provided in lieu of spare charges;

**.5** fire extinguishers shall be mounted in special brackets of quick-detachable type at places easily visible and accessible in case of fire, and in such a way that their serviceability is not impaired by the weather, vibration and other external factors.

They shall be located at the height of not more than 1,5 m from deck and not closer than 1,5 m from sources of heat;

**.6** one of the portable fire extinguishers intended for use in any space shall be stowed close to the entrance to that space;

**.7** each powder or carbon dioxide fire extinguisher shall have capacity not less than 5 kg, and each foam fire extinguisher - not less than 9 l.

Mass of any portable fire extinguisher shall not exceed 23 kg. Portable fire extinguishers shall have efficiency, which, in compliance with the recognized international or national standard, is at least equivalent to the efficiency of a 9-litre wetting agent fire extinguisher, which is determined when extinguishing model fire seat of A class, rating 2A;

**.8** powder fire extinguishers shall be selected with regard for the purpose of the powder extinguishing medium;

**.9** in the machinery spaces fire extinguishers shall be so located that an extinguisher is not more than 10 m walking distance from any point in the space;

**.10** carbon dioxide fire extinguishers shall not be located in accommodation spaces. In control stations and other spaces containing electrical or electronic equipment or facilities required for ship safety, fire extinguishers shall be provided, charged with the fire extinguishing medium, which does not conduct electricity and does not cause harm to equipment and facilities;

**.11** portable fire extinguishers shall be provided with a visual indication of discharge;

**.12** casing and other components of the fire extinguishers subject to internal pressure shall be tested by hydraulic pressure:

2,7 times exceeding the maximum working pressure, but not less than 5,5 MPa for the low pressure fire extinguishers (with working pressure not more than 2,5 MPa at environmental temperature of 20°C);

determined in accordance with recognized national standard on safety of pressure vessels - for high pressure fire extinguishers (with working pressure more than 2,5 MPa at environmental temperature of 20°C);

**.13** fire extinguishers shall be suitable for operation under exposure to ambient temperatures according to Table 2.3.1-2, Part VII "Machinery Installations" with due regard for the materials used and maximum degree of filling established by the manufacturer. The degree of filling for carbon dioxide fire extinguishers shall not exceed 0,75 kg/l;

**.14** materials used for the manufacture of fire extinguishers, which can be exposed to marine environment during operation shall be selected with consideration for their compatibility;

**.15** each fire extinguisher shall be clearly marked with at least the following information:

**.15.1** manufacturer;

**.15.2** types of fire for which the fire extinguisher is suitable and its fire-extinguishing capability (i.e. capability to extinguish a model fire seat under certain conditions);

**.15.3** type and nominal quantity of extinguishing medium with which the fire extinguisher is charged;

**.15.4** information on the Register approval;

**.15.5** instruction on actuating the fire extinguisher in the form of several pictograms with explanatory note in the language understandable to potential user, in general case, in Ukrainian and in English;

**.15.6** year of manufacture;

**.15.7** range of temperatures within which the fire extinguisher is operable;

**.15.8** test pressure.

**5.1.10** Foam fire extinguishers of at least 45 and 135 l shall meet the following requirements:

**.1** fire extinguishers shall be located within the protected space, in regular fixed places near the exits.

Only fresh water shall be used for charging the fire extinguishers;

**.2** the air for an air-foam extinguisher shall be kept in a cylinder provided solely for that particular extinguisher. The quantity of air in the cylinder shall be at least 25% in excess of the rated amount. The air cylinder shall be fitted with a pressure gauge;

**.3** fire extinguishers having capacity of not less than 135 l shall be provided with hoses winded on reels and provide access to any place of boiler room;

**.4** location of 45-litre fire extinguishers (or their equivalents) in machinery spaces, specified in **5.1** and **5.2** of Table 5.1.2, shall ensure the delivery of the fire extinguishing medium to any part of the fuel system, to pressure lubricating systems, drives casings covering turbine parts lubricated under pressure, engines and associated drives and other fire risk equipment. In cargo ships a fire extinguisher having a capacity of 45 l (or equivalent) may be located outside the space for which it is intended.

**5.1.11** Carbon dioxide or dry powder fire extinguishers of at least 16 kg, as well as carbon dioxide or dry powder fire extinguishers of at least 45 kg shall meet the following requirements:

**.1** carbon dioxide fire extinguishers shall not be used in spaces of such volume that the complete discharge of the carbon dioxide contained in the cylinders is liable to cause concentration of carbon dioxide in excess of 5 %;

**.2** an extinguishing medium shall be delivered to any part of the protected space through fire hoses of 10 - 15 m in length and through pipes if necessary;

**.3** fire extinguishers shall be placed near the exits in the spaces and shall be protected against mechanical damage.

**5.1.12** Metal receptacles containing sand or dry sawdust impregnated with soda shall comply with the following requirements:

**.1** the capacity of the receptacles shall be at least 0,1 m<sup>3</sup>;

**.2** each receptacle shall be provided with a readily opening watertight cover, a scoop and a device for holding the cover in the open position unless it is an easily removable cover.

**5.1.13** Fire smothering blankets shall comply with the following requirements:

**.1** they shall be sufficiently stout and durable;

**.2** as a rule, they are to be made of non-combustible material; clean unraised thick felt may be used;

**.3** blankets shall be stowed in special cases or lockers;

**.4** they shall have an area of at least 3 m<sup>2</sup> and be similar to a square or circle in shape.

**5.1.14** Complete sets of fire fighting tools shall comply with the following requirements:

**.1** one complete set shall include one fire axe and one light-weight fire crowbar;

**.2** the sets of fire fighting tools shall be stowed on regular boards. The fastening of the tools shall permit of ready availability of the tools for use;

**.3** in ships for the carriage of motor vehicles with fuel (other than diesel oil) in their tanks one set of tools shall be placed near the exits from the accommodation and machinery spaces to cargo spaces.

**5.1.15** The fireman's outfit shall include:

**.1** personal outfit consisting of:

**.1.1** protective clothing of material approved by the competent bodies to protect the skin from the heat radiating from the fire and from burns and scalding by steam. The outer surface shall be water-resistant; tarpaulin and polyvinylchloride clothes are not allowed for the outer material of the fireman's outfit;

**.1.2** boots and mittens of rubber or of some other dielectric material;

**.1.3** a rigid helmet ensuring effective protection against impacts;

**.1.4** a portable safe manual lantern with a minimum burning period of 3 h.

In ships carrying dangerous goods, in oil tankers and other ships having cargo spaces and spaces where a flammable gas, vapour or dust/air mixture is present or may arise, provision shall be made for explosionproof lamps with explosion group IExd or IExp. The explosion group and temperature class shall be consistent with the category of the cargo carried. For example, they are IExd IIAT3 and IExp IIT3 for oil, kerosene and a number of gasolines;

**.1.5** a fire axe with a helve made of hard wood; if the helve is made of some other material, it shall be insulated with some suitable dielectric material;

**.2** a self-contained compressed air-operated breathing apparatus, the volume of air contained in the cylinders of which shall be at least 1200 l or other self-contained breathing apparatus which shall be capable of functioning for at least 30 min. Compressed air breathing apparatus shall be fitted with an audible alarm and a visual or other device which will alert the user before the volume of the air in the cylinder has been reduced to no less than 200 l.

Each breathing apparatus shall be provided with a flexible fire resisting lifeline, not less than 30 m in length. The lifeline shall be subjected to a test by static load of 3,5 kN for 5 min and withstand this load without damage. The lifeline shall be fastened to the harness of the apparatus or to a separate belt by means of a snap hook to preclude spontaneous separation of the line from the apparatus.

Provision shall be made for two spare charges or two spare breathing apparatuses per each required self-contained breathing apparatus. All air cylinders for the apparatus shall be interchangeable.

Passenger ships carrying not more than 36 passengers and cargo ships equipped with suitably located means for fully recharging breathing air cylinders by clean air may have only one spare charge for each breathing apparatus or one spare breathing apparatus per each required self-contained breathing apparatus.

In passenger ships carrying more than 36 passengers, two spare charges or two spare breathing apparatus shall be provided per each required self-contained breathing apparatus.

Passenger ships carrying more than 36 passengers constructed on or after 1 July 2010 shall be fitted with a suitably located means for fully recharging breathing air cylinders, free from contamination.

For fire drills, all ships shall be provided with an onboard means of recharging breathing apparatus cylinders or a suitable number of spare cylinders – at least one set of cylinders for each mandatory breathing apparatus, unless additional spare cylinders are required by the shipboard safety management system (SMS).

No additional cylinders are required for fire drills for breathing apparatus sets required by Section 7 of this Part, the IMSBC Code, the IBC Code or the IGC Code. The means for recharging shall be either:

breathing air compressors supplied from the main and emergency switchboard, or independently driven, with a minimum capacity of 60 l/min per required breathing apparatus, not to exceed 420 l/min; or

self-contained high-pressure storage systems of suitable pressure to recharge the breathing apparatus used on board, with a capacity of at least 1200 l per required breathing apparatus, not to exceed 50 000 l of free air;

**.3** on existing ships contracted for construction before 1 July 2014, a minimum of two two-way portable radiotelephone apparatus of an explosion-proof type or intrinsically safe for each fire party.

Ships constructed before 1 July 2014, shall comply with the requirements of this paragraph not later than the first survey after 1 July 2018.

On ships constructed on or after 1 January 2018 a minimum of two two-way portable radiotelephone apparatus shall be provided. These apparatus for ships using LPG (refer to **6.8**), ro-ro ships and ships with special category spaces shall be of an explosion-proof type.

Ships constructed before 1 January 2018, shall comply with the requirements of this paragraph not later than the first periodical survey after 1 July 2019.

**.4** Fireman's outfit and personal equipment shall be ready for use and stored in readily accessible locations that are permanently and clearly marked and where more than one fireman's outfit or more than one set of personal equipment is carried on board they shall be stored in widely separated places.

In passenger ships at least two fireman's outfits and, in addition, one set of personal equipment shall be available at any such place. At least two fireman's outfits shall be stored in each main vertical zone.

**5.1.16** Portable electric drills shall be provided with an electric cable of sufficient length. The use of pneumatic drills instead of electric ones is permitted. The electric or pneumatic drills specified in item 11 of Table 5.1.2 may be reckoned in the number of the items prescribed for other types of ship's outfit.

**5.1.17** Portable diesel fire motor-pumps shall comply with the following requirements:

**.1** the pump shall ensure simultaneous operation of at least two fire hose nozzles with an outlet diameter of at least 12 mm at a pump discharge pressure of at least 0,2 MPa and at vacuum in suction piping not less than 0,05 MPa; centrifugal pumps shall be fitted with a self-priming device;

**.2** the pump motor shall be capable of being readily started either by hand or by special starters both at above-zero and below-zero ambient temperatures. The motor shall be provided with a quantity of fuel to ensure the operation of the pump for 1,5 h without refuelling; the ship shall carry an additional reserve of fuel for refuelling;

**.3** each motor-pump shall be provided with suction hoses, to a total length of 8 m, fitted with a suction strainer and a non-return valve, two delivery hoses, each 10 m long, two-dual purpose fire hose nozzles with an outlet diameter of at least 12 mm and a branch coupling for connecting two hoses;

**.4** the dimensions and type of coupling for the delivery hoses and nozzles shall correspond to those used in the fixed water fire extinguishing systems fitted in the ship;

**.5** the motor-pumps shall be provided with tools and accessories in compliance with the manufacturer's specification;

**.6** motor-pumps for use in ships navigating under northern latitudes shall be placed in heated spaces, together with the suction and delivery hoses and nozzles.

**5.1.18** The international shore connection (refer to Fig. 5.1.18) for water supply from shore shall be in accordance with the following specification:

outside diameter of flange - 178 mm;

inside diameter of flange - 64 mm;

bolt circle diameter - 132 mm;

holes - 4 equispaced holes 19 mm diameter equidistantly placed, slotted to the flange periphery;

flange thickness - at least 14,5 mm;

bolts - 4 pcs, each 16 mm in diameter and 50 mm in length;

bolt nuts - 4 pcs, 16 mm in diameter;

washers for bolts - 8 pcs.

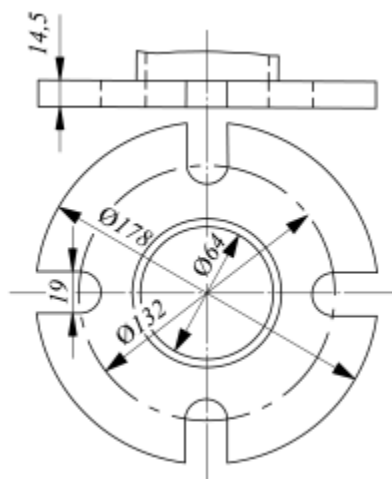

Fig. 5.1.18

International shore connection (ship)

On one side the shore connection shall have a flat-faced flange with dimensions as above, and on the other a quick-acting coupling which shall correspond to the ship's hydrants and hoses both in dimensions and design.

The shore connection, gasket, bolts and nuts shall be made of materials suitable for 1,0 MPa.

The shore connection complete with gasket, four bolts, four nuts and eight washers shall be stowed together with other items of fire fighting outfit in an easily accessible position.

**5.1.19** Portable medium expansion mechanical foam generators and portable combination-foam production units shall comply with the following requirements:

**.1** concentrate solution discharge at a pressure of 0,6 MPa, not less than 360 l/min (refer also to 3.7.2.2);



.2 foam jet range, at least 8 m;

.3 rated number of foam generators/units shall be determined by the formula

$$N=Q/q \quad (5.1.19.3)$$

where  $Q$  - solution capacity of the system, in l/min;

$q$  - solution capacity of a foam generator/unit, in l/min.

50 % of the foam generators/units and extension pipes required by items 2.4 and 2.5 of Table 5.1.2 shall be placed in the poop, the remainder, in the forecastle and midship superstructure, if any.

**5.1.20** For applicator shall consist of L-shaped pipe with long side of about 2 m fitted for connection to fire hoses and short side of about 0,25 m equipped with fixed nozzle for producing water for or fitted for connecting water-spraying nozzle.

These applicators shall be located near the fire hydrants and those for breathing apparatus near the latter.

**5.1.21** Fire buckets shall be provided with the hemp rope of sufficient length and shall be stowed on the open decks in easily accessible places. The buckets shall be painted red and bear inscription "**FIRE**".

**5.1.22** In tankers and combination carriers gas analyzers shall meet the following requirements:

.1 provision shall be made for use of gas analyzers with gas sampling pipes as specified in 9.14.1, Part VIII "Systems and Piping";

.2 suitable means shall be provided for the calibration of gas analyzers;

.3 gas analyzers shall be provided with a set of spares supplied by the manufacturer.

Alternatively ship may be additionally equipped with one portable instrument for measuring oxygen and one for measuring flammable vapour concentrations, or with two gas analyzers, each capable of measuring both oxygen and flammable vapour concentrations.

**5.1.23** In all passenger and cargo ships of 500 gross tonnage and over provision shall be made for emergency escape breathing devices (EEBD) of a Register-approved type which shall be only used for emergency escape from a compartment with a hazardous atmosphere. EEBD shall not be used by crew for fighting fires, entering oxygen deficient void spaces or tanks. In such cases a self-contained breathing apparatus specified in **5.1.15.2** shall be used.

EEBD shall meet the following requirements:

.1 EEBD shall provide service duration of at least 10 min;

.2 EEBD shall protect eyes, nose and mouth during escape and consist of a helmet fully covering head, neck and may cover portions of the shoulders, or a mask fully covering the face so as to form a complete seal around the eyes, nose and mouth, which is secured by suitable means. The helmets and masks shall be manufactured of flame resistant materials and include a clear window for viewing;

.3 an inactivated EEBD shall be carried hands-free;

.4 EEBD shall be designed so that to enable quick and easy dressing. Brief instructions or diagrams clearly illustrating their use shall be clearly printed on each EEBD.

An EEBD, when stored, shall be suitably protected from weather exposure.

Maintenance requirements, manufacturer's trademark and serial number, shelf life and date of manufacture shall be printed on each EEBD. EEBD intended for training shall have appropriate distinct marking.

The number and location of EEBD shall be indicated on fire control plans (refer to **1.4**).

## **5.2 SPARE PARTS AND TOOLS**

**5.2.1** A ship shall carry spare parts and tools, the number of which shall be not less than that specified in Table 5.2.1.

**Table 5.2.1**

Nos.	Description of spare parts and tools	Number per ship
<b>1</b>	<b>2</b>	<b>3</b>
1	Water fire main system:	1 pc of each
	.1 a fire hose of each length and diameter fitted complete with couplings	
	.2 connection couplings for each size fitted (if the ship is provided with hydrants of various diameters)	2 pcs
	.3 quick-acting couplings (hose couplings)	2 pcs (of each diameter)
	.4 quick-acting couplings (hose couplings) for ships of 4000 gross tonnage and upwards	4 pcs (of each diameter)

	.5 rubber rings for packing of joints between couplings, hoses and apparatuses	5 % of total number, but not less than 10 pcs
	.6 hose clamps	4 pcs (for ships of less than 300 gross tonnage, as many as the number of hoses, but not more than 4)
	.7 wrenches for engaging or disengaging couplings (where nozzles are fitted by means of a special wrench)	according to the number of hydrants.
	.8 fire hydrant of each size fitted, in assembly	1 pc of each size
	.9 handwheel to fire hydrant of each size fitted	1 pc of each size
	.10 valve disks with packing rings to fire hydrants of each size fitted	1 pc of each size
2	Sprinkler system: .1 sprinkler heads, in assembly	The number of spare sprinkler heads shall be determined proceeding from their type and number already fitted on board: 6 – for systems having less than 300 heads; 12 – for systems having 300 to 1000 heads; 24 – for systems having more than 1000 heads
	.2 wrenches for sprinkler heads (where heads are fitted by means of a special wrench)	1 pc per section
	.3 parts for control valve	1 set, according to delivery specification
3	Pressure water-spraying, water-screen, drenching systems: .1 spray nozzles of various types fitted in the system	5 % of total number of spray nozzles fitted
	.2 wrench for spray nozzles (where nozzles are fitted by means of a special wrench)	1 pc
4	Foam fire extinguishing system: .1 hydrant of each size fitted, in assembly	1 pc
	.2 fixed air-foam nozzle or foam generator	1 pc
	.3 gauge glasses for tanks	1 pc
	.4 rubber rings for joints	10 pcs
5	Carbon dioxide smothering system: .1 cylinder valves, assembled; for the number of cylinders: below 50 50 to 100 100 and over	1 pc 2 pcs 3 pcs
	.2 wrenches for assembling and disassembling cylinder valves and other special valves	set per station
	.3 plugs to be fitted on pipes leading from cylinder valves, when cylinders are removed	25 % of the number of cylinders
	.4 protective diaphragms	In accordance with the number of cylinders
	.5 thrust bushes and washers for protective devices	10 % of the number of cylinders
	.6 non-return valves	5 % of total number, but not less than 1 pc
	.7 discharge nozzles of each type and size fitted	2 pcs
	.8 scales for weighing cylinders or carbon dioxide level gauge	1 pc
	.9 parts of tank carbon dioxide contents gauge	In accordance with delivery specification
6	Dry powder system:	set of each

	.1 parts of release devices for hand hose lines and monitors	
	.2 nozzles of each type and size	1 - 2 pcs
	.3 wrenches for assembling and disassembling valves, hand hose lines, nozzles	1 set
7	Aerosol system: .1 generator of fire extinguishing aerosol	One generator of each type used
8	Miscellaneous items, for all systems: .1 instruments and gauges: pressure gauges, vacuum gauges, thermometers of each type fitted in systems	1 pc of each
	.2 adequate quantity of packing material for onboard repairs	1 set
	.3 fuses for automatic closing of fire doors and dampers	In accordance with number of doors and dampers thus controlled
	.4 spare parts for pumps, fans, compressors and engines serving fire extinguishing systems	In accordance with Section 5, Part VII "Machinery Installations"
	.5 spare parts for electrical equipment of fire extinguishing systems	In accordance with Section 21, Part XI "Electrical Equipment"

The quantities prescribed in the Table apply to fixed fire extinguishing systems only.

**5.2.2** The spare parts and tools for the systems shall be kept in the fire extinction stations. Spare parts shall be suitably marked.

## 6 REQUIREMENTS FOR FIRE PROTECTION OF SPECIAL PURPOSE SHIPS AND SPECIAL FACILITIES ON SHIPS

### 6.1 SHIPS EQUIPPED WITH HELIDECKS

#### 6.1.1 Fire protection measures for helidecks.

**6.1.1.1** Requirements of this subsection supplement the requirements of Sections 1 – 5 and shall apply to helidecks and its fuel filling equipment, as well as to helicopter hangars.

**H a n g a r** is a purpose-built space for helicopter storage and/or maintenance and repair.

**H e l i d e c k** is a purpose-built helicopter take-off and landing area including all structures, firefighting appliances and other equipment necessary for the safe operation of helicopters.

**H e l i c o p t e r f a c i l i t y** is a helideck with helicopter refueling, compressed gases facilities, if any, and special liquids facilities, helicopter service spaces, if any, and a hangar.

#### 6.1.2 Fire protection of helidecks.

**6.1.2.1** The helideck shall be provided with both main and emergency means of escape and access for fire-fighting and rescue personnel. These shall be located as far apart from each other as practicable, and preferably on the opposite sides of the helideck.

If more than 50 % of the helideck area is projected from the main ship structure, it is recommended to arrange two entrances to helideck within the range of such overhanging parts that is providing at least one exit from helideck to windward side in case of fire.

**6.1.2.2** Helideck shall be protected by a fixed foam fire extinguishing system according to item 20 of Table 3.1.2.1 of Part VI "Fire Protection".

##### 6.1.2.2.1 Fixed foam fire extinguishing system.

The minimum foam system discharge rate shall be determined the helideck area and foam discharge rate. The minimum foam system discharge rate shall be determined by multiplying the *D*-value area by 6 l/min/m<sup>2</sup>.

The quantity of foam concentrate shall be adequate to allow operation of all connected discharge devices for at least 5 min. The foam system shall be designed to discharge foam with nominal flow and at design pressure from any connected discharge devices within 30 s of activation.

The foamer must be suitable for sea water and at least meet the minimum requirements of International Civil Aviation Organization (ICAO).

The location and characteristics of the equipment of the foam fire extinguishing system shall provide extinguishing of fire on helicopter high-level units.

It is recommended to provide additionally 100 % reserve of foam concentrate for supply of its calculated value in case of helicopter landing after partial use of foam concentrate in testing, drills or fire extinction.

**6.1.1.2.2 Water fire extinguishing system.**

The number and position of fire hydrants shall be such that at least two jets of water may reach any part of the helideck.

**6.1.1.2.3** In close proximity to the helideck the following fire-fighting outfit shall be provided and stored near the means of access to that helideck:

.1 at least two dry powder fire extinguishers having a total capacity not less than 45 kg;

.2 carbon dioxide fire extinguishers having a total capacity not less than 18 kg or equivalent; fire extinguishers shall be equipped with flexible nozzles for extinguishing a fire in the upper part of a helicopter;

.3 at least two nozzles of an approved dual-purpose type with hoses sufficient to reach any part of the helideck;

.4 at least two sets of fireman's outfits in addition to those required by item **10** of Table 5.1.2;

.5 at least the following equipment stored to provide its immediate use and protection from weather exposure:

adjustable wrench;

blanket (fire resistant);

cutter with at least 60 cm handle;

hook, grab or salving;

hacksaw, heavy duty, complete with 6 spare blades;

ladder;

lift line of 5 mm diameter and 15 m in length;

pliers, side-cutting;

set of assorted screwdrivers;

harness knife complete with sheath;

large crowbar (recommended);

3 pairs of fire resistant gloves (recommended);

large rescue axe (recommended);

side cutting pliers (tin snips) or equivalent cutting tool (recommended).

**6.1.1.2.4** Drainage facilities in way of helidecks shall comply with the requirements of **7.12.6**, Part VIII «Systems and piping».

**6.1.3 Fire protection of hangars and spaces where helicopter refuelling and maintenance facilities are located.**

**6.1.3.1** Structural fire protection, fixed fire extinguishing systems and fire detection and alarm systems and fire-fighting outfit for hangars and spaces where helicopter refuelling and maintenance facilities are located shall be similar to those of category A machinery spaces.

**6.1.3.2** The boundary structures of hangars and spaces where helicopter refuelling and maintenance facilities are located shall be made of steel.

**6.1.3.3** Refuelling station for helicopters shall meet the following requirements:

.1 the boundaries and means of closing openings at the station shall secure gas tightness thereof. Doors leading to the station shall be of steel;

.2 deck covering shall preclude spark formation. Arrangements and machinery shall be so arranged and located as to exclude the possibility of spark formation;

.3 pipelines and cables passing through the boundaries of the station shall not cause loss of its gas tightness;

.4 storage tank fuel pumps shall be provided with means which permit remote shutdown from a safe location in the event of a fire. Where a gravity-fuelling system is installed, equivalent closing arrangements shall be provided to isolate the fuel source;

.5 where several fuel tanks are fitted, the fuel system design shall provide for fuel supply to the helicopter being refuelled only from one tank at a time;

.6 provision shall be made for the arrangement whereby a fuel spillage may be collected and drained into an off-grade fuel tank;

.7 fuel oil piping shall be of steel or equivalent material, as short as possible, and protected against damage;

.8 the refuelling facility shall incorporate a metering device to record the quantity of supplied fuel, a flexible hose with a nozzle fitted with a self-closing valve and a device to prevent over-pressurization of the fuel system.

**6.1.3.4** The number and position of the hydrants shall be such that at least three jets of water may reach any part of the hangar.

**6.1.3.5 "NO SMOKING"** signs shall be displayed at appropriate locations in hangars and spaces where helicopter refuelling and maintenance facilities are located.

**6.1.3.6** Storage of flammable liquids and materials, paint materials, lubricating oils, hydraulic liquids and any types of fuel in hangar is not allowed.

## **6.2 SPECIAL PURPOSE SHIPS**

### **6.2.1 General.**

**6.2.1.1** The fire protection of special purpose ships shall be arranged depending on the number of persons carried on board:

.1 not more than 60 persons - equivalent to that of cargo ships of more than 500 gross tonnage;

.2 more than 60, but not more than 240 persons - equivalent to that of passenger ships carrying not more than 36 passengers;

.3 more than 240 persons - equivalent to that of passenger ships carrying more than 36 passengers.

**6.2.1.2** Fire protection of working spaces specified in **1.5.8** shall be arranged with due regard for the purpose of the working space and equipment located therein. As a rule the fire protection of working spaces shall be equivalent to that of service spaces specified in **1.5.3**.

### **6.2.2 Storerooms for explosives (magazines).**

**6.2.2.1** In special purpose ships the arrangement of storerooms for explosives (magazines) may be permitted. The magazines shall be of the following types:

.1 integral magazines forming an integral part of the ship;

.2 portable magazines that are non-integral, portable magazines with a capacity of 3 m<sup>3</sup> or greater;

.3 magazine boxes that are non-integral, portable magazines with a capacity of less than 3 m<sup>3</sup>.

**6.2.2.2** Integral magazines shall be located in the forward or after portion of the ship and be located not less than one watertight space apart from the propeller shaft, propeller and rudder. They shall not be located below accommodation spaces, control stations and be adjacent to them.

**6.2.2.3** Integral magazines shall not be adjacent to machinery spaces of category A, galleys and other dangerous spaces. If it is necessary to locate the magazine in proximity to these areas, a cofferdam of at least 0,6 m shall be provided separating two spaces. Such a cofferdam shall not be used for stowage and shall be provided with ventilation. One of the bulkheads forming the cofferdam shall be of "A-15" class, if it is adjacent to machinery space of category A it shall be "A-30" class.

**6.2.2.4** Access to integral magazines shall preferably be from the weather deck, but in no case through spaces specified in **6.2.2.2** and **6.2.2.3**.

**6.2.2.5** Portable magazines and magazine boxes shall be located on a weather deck in a location protected from direct impact of the sea. The location shall provide sufficient protection against warm air and hazardous vapours being emitted from galleys, pump rooms, etc. Due regard shall be paid to possible risk of subjecting certain explosives to radio emissions.

**6.2.2.6** Magazine boxes shall be located on a weather deck at least 0,1 m from the deck and any deckhouse and in a position suitable for jettisoning the contents.

**6.2.2.7** Bulkheads and decks bounding integral magazines shall be of watertight construction of "A-15" class. If the spaces adjacent to the magazines contain no combustible materials the construction may be of "A-0" class. Insulation shall be provided to prevent condensation of moisture.

**6.2.2.8** Piping of fresh or salt water and drainage systems and piping of systems installed in the magazines themselves may be routed through magazines. Piping of other systems shall be permitted only if they are enclosed in a watertight trunk.

**6.2.2.9** The magazines shall be provided with means to ensure their effective closing and to prevent unauthorized access.

**6.2.2.10** Racks, supports and other means shall be installed, the construction and capacity of which shall provide safe stowage of explosives in their approved containers with minimum dunnage and to prevent them from shifting and falling when the ship is rolling.

The upper rack shall not be located higher than 1,8 m above the deck. The racks shall have holes for water flowing from the upper to the lower racks during operation of the drenching system.

**6.2.2.11** Decks of magazines shall be covered with a permanent non-slip, non-sparking covering.

**6.2.2.12** A free volume of the magazine, when loaded, shall be at least 70 % of the entire magazine volume. Not more than 100 kg of explosives or 1000 detonators shall be placed for each 1 m<sup>2</sup>.

**6.2.2.13** Integral magazines shall be provided with natural or mechanical ventilation fitted with flame arresters sufficient to maintain the magazine temperature not higher than 38°C.

**6.2.2.14** Portable magazines shall have watertight metal construction insulated with non-combustible materials on the inside as a construction of "A-15" class.

**6.2.2.15** Portable magazine shall bear a label indicating mass in light condition and maximum permissible mass of explosives.

**6.2.2.16** Portable magazines shall be provided with efficient natural ventilation fitted with flame arresters.

**6.2.2.17** Magazines shall be fitted with automatic heat detectors operating at temperatures rising above 40°C. An appropriate visible and audible alarms actuated by this detector shall be provided in the wheelhouse and in the chief mate's cabin.

**6.2.2.18** Integral and portable magazines shall be fitted with drenching systems in accordance with 3.6. The controls shall be clearly marked with indication of their purpose.

**6.2.2.19** Magazines shall be fitted with scuppers. The scupper pipes shall be provided with valves which shall be kept permanently closed under normal service conditions. The valves shall be controlled from outside the magazines.

**6.2.2.20** Integral and portable magazines shall be clearly marked:

"The space is a magazine";

"Open lights and flame shall be kept away";

"The magazine door shall be locked";

"Matches and lighters shall be removed prior to entering";

"Do not lift with contents" (in case of portable magazines).

**6.2.2.21** Magazine boxes shall have watertight metal construction with walls and lids not less than 3 mm thick. Boxes exposed to sunrays shall be protected with solar screens.

**6.2.2.22** Magazine boxes shall be clearly labeled:

"The container is a magazine box";

"Open lights and flame shall be kept away";

"The box shall be locked".

**6.2.2.23** Electrical equipment in magazines shall comply with the requirements of **19.4.3**, Part XI "Electrical Equipment" and other applicable requirements of the above Part.

**6.2.2.24** Detonators shall be stowed separately from other explosives.

**6.2.2.25** Charging of cartridges and other preparatory operations for using explosives shall be made in charging rooms which shall be specially provided for that purpose. Charging rooms shall be arranged in steel enclosures and located on the weather deck apart from control stations, accommodation and service spaces. Bulkheads, decks and equipment of the charging rooms shall be faced with non-sparking materials.

### **6.2.3 Carriage of dangerous goods.**

Dangerous goods on special purpose ships shall be carried in accordance with the provisions of Chapter 7 "Dangerous Goods" of the SPS Code<sup>12</sup>, as amended.

## **6.3 OIL TANKERS (> 60°C)**

**6.3.1** The fire protection of oil tankers (> 60°C) shall be equivalent to that of cargo ships having regard of the following:

**.1** a fixed deck foam fire extinguishing system complying with the requirements of **3.7** shall be fitted;

**.2** the water fire main system shall additionally meet the requirements of **3.2.5.4**;

**.3** two additional sets of fireman's outfit in accordance with item **10.2** of Table 5.1.2 shall be provided.

**6.3.2** In addition to the requirements of **6.3.1** the following shall be provided:

**.1** cargo tanks shall not be adjacent to accommodation spaces;

**.2** air intakes and other openings leading to accommodation spaces shall not be faced to cargo area.

Entrance doors in bulkheads of superstructures and deckhouses facing cargo area may be installed only in cases if they do not lead to accommodation spaces;

**.3** a continuous coaming not less than 150 mm high extending from side to side shall be fitted on the upper deck at a distance of about 2 m from a superstructure where accommodation and service spaces are arranged;

**.4** machinery spaces of category A shall be in general arranged aft beyond cargo and slop tank area.

**6.3.3** Where cargo heating arrangements are fitted, provision shall be made to prevent cargo from heating up to the temperature which is not less than 15°C lower than the flash temperature.

## **6.4 OIL RECOVERY SHIPS AND BILGE WATER REMOVING SHIPS**

**6.4.1** The fire protection of oil recovery ships shall be equivalent to that of oil tankers to the extent applicable for the individual ship project and, in addition, meet the requirements of 6.4.4 - 6.4.10.

When exterior boundaries of superstructures and deckhouses enclosing accommodation and including any overhanging decks, which support such accommodation, are protected by a steel bulkhead screening

<sup>12</sup> Refer to IMO Resolution MSC.266 (84): "Special Purpose Ship Safety Code 2008 (SPS Code)".

them from the cargo area and installed at a distance of minimum 3 m from them from side to side, compliance with the requirements of 2.4.3, as well as of 2.4.4 and 2.4.5 is not required. Openings for free passage of people, ship systems piping, mooring and towing lines etc., the total area of which at each tier of a superstructure or a deckhouse shall not exceed 10 % of the area equal to the width of the side multiplied by the height of the tier of the superstructure or deckhouse, are permitted in the screening bulkhead.

**6.4.2** The fire protection of oil recovery ships (> 60°C) shall be equivalent to that of oil tankers (> 60°C) and in addition meet the requirements of 6.4.4 and 6.4.10.

**6.4.3** The fire protection of bilge water removing ships shall be equivalent to that of oil tankers (> 60°C) and in addition meet the requirements of 6.4.10.

**6.4.4** The hull, superstructures, structural bulkheads, decks and deckhouses shall be manufactured of steel. The use of aluminium alloys for this purpose is not permitted.

**6.4.5** The spaces intended for removable equipment which is used for oil recovery shall meet the following requirements:

- .1 fire integrity of their structures shall meet the requirements of 2.4.2 for service spaces of category (9);
- .2 they shall be protected by fire extinguishing system according to item 6 of Table 3.1.2.1;
- .3 may be regarded as cofferdams specified in 2.4.7.

**6.4.6** The ship shall be protected by a fixed water spraying system with the rate of water discharge

- .1 10 l/min per 1 m of the exterior boundaries of superstructure;
- .2 5 l/min per 1 m<sup>2</sup> of the horizontal area of the cargo zone.

A fixed water spraying system, specified in 6.4.6.2, may not be installed if the fixed deck foam system provides effective cooling by water of all area of a cargo zone by monitors remotely controlled from the wheelhouse.

controlled from the navigating bridge.

**6.4.7** The water fire main system and drenching and foam fire extinguishing systems specified in 6.4.6 shall use sea water coming only from sea openings arranged in ship's bottom.

**6.4.8** Remote starting of fire pumps, fixed fire extinguishing systems for machinery space of category A and drenching systems specified in 6.4.6 shall be provided from navigation bridge.

**6.4.9** The high expansion foam system shall not be used for protection of spaces specified in 6.4.5.

**6.4.10** The ship shall be provided with a fixed or portable oil flash point tester.

**6.4.11** For small ships of up to 1000 t deadweight periodically engaged in recovery of oil products at the sea surface, the fixed automatic system for atmosphere monitoring may be replaced, on agreement with the Register, by a monitoring system with portable analyzers specified in item 15.1 of Table 5.1.2.

Atmosphere monitoring shall be applied during the whole period of stay of the ship within oil spot in locations specified in 9.14.5, Part VIII "Systems and Piping".

## **6.5 BERTH-CONNECTED SHIPS**

**6.5.1** The fire protection of berth-connected ships used as floating hotels, hostels, offices and restaurants shall be designed depending on the number of residents or persons who sojourn therein during working hours:

- .1 up to 60 persons - equivalent to that of cargo ships of more than 500 gross tonnage;
- .2 from 60 up to 200 persons - equivalent to that of passenger ships carrying not more than 36 passengers;
- .3 more than 240 persons - equivalent to that of passenger ships carrying more than 36 passengers.

**6.5.2** The fire protection of floating docks, cranes, power plants, workshops, warehouses and other ships shall be equivalent to that of cargo ships of more than 500 gross tonnage.

However, in case of 50 and more residents or persons who sojourn therein during working hours, other than crew members, the fire protection shall comply with the requirements of 6.5.1.2 or 6.5.1.3.

**6.5.3** For berth-connected ships operating at shore quay wall the Register may revise the requirements specified in 6.5.1 and 6.5.2, taking into account operating conditions of the ship and its fire protection determined by the ship designer on agreement with the customer.

## **6.6 SHIPS HAVING A DISTINGUISHING MARK FOR A SHIP CARRYING EQUIPMENT FOR FIRE FIGHTING ABOARD OTHER SHIPS**

**6.6.1** The fire protection of ships having a distinguishing mark for a ship carrying equipment for fire fighting aboard other ships shall be equivalent to that of other ships with due regard for the following:

- .1 hull, superstructures, deckhouses and decks shall be made of steel. In ships having distinguishing marks **FF1WS**, **FF2WS**, **FF3WS** in class notation, the superstructures and deckhouses may be manufactured of aluminum alloys, provided they are protected with fire protection systems in compliance with 6.6.6 or 6.6.7;
- .2 structural fire protection shall be made in compliance with the *IC method*.

**6.6.2** Ships shall be provided with a fire and rescue operations control station. The control station shall be placed so that the ship structures do not impair, as far as practicable, the vision of the water around the ship.

**6.6.3** The ships shall have:

special systems and equipment, the minimum number of which is indicated in Tables 6.6.3-1 and 6.6.3-2;

items of fire-fighting outfit in compliance with **6.6.11.1**;

additional bilge arrangements (systems) and additional reserve of fuel in accordance with **7.1.10** and **13.7.7**, Part VIII "Systems and Piping";

additional internal service communications in compliance with **7.2.2**, Part XI "Electrical Equipment".

**6.6.4** Special systems installed on board ships for fire-fighting on other objects and for their own protection (water-screen, drenching, water fire main, foam fire extinguishing, dry powder systems) shall also comply with the requirements of Section 3 of this Part and Sections 2, 4, 5, Part VIII "Systems and Piping".

Where special systems other than specified in this Section of the Rules are installed, they shall comply with the requirements of the Rules to the extent agreed with the Register in each particular case.

**Table 6.6.3-1**

Special systems	Distinguishing mark in the class notation				
	FF1	FF1WS	FF2	FF2WS	FF3WS
Water-screen system <sup>1</sup>	-	+	-	+	+
Drenching system <sup>1</sup>	-	+	-	+	+
Water fire main system	+	+	+	+	+ <sup>2</sup>
Foam fire extinguishing system	+	+	+	+	+
Dry powder system	+ <sup>3</sup>	+ <sup>3</sup>	+ <sup>3</sup>	+ <sup>3</sup>	+ <sup>3</sup>
Bilge system <sup>4</sup>	+	+	+	+	-
<sup>1</sup> Refer to <b>6.6.6.6</b> .					
<sup>2</sup> Refer to <b>6.6.8.2</b> .					
<sup>3</sup> Refer to <b>6.6.10.1</b> .					
<sup>4</sup> Refer to <b>7.1.10</b> , Part VIII "Systems and Piping".					

**Table 6.6.3-2**

Special equipment	Distinguishing mark in the class notation		
	FF1 FF1WS	FF2 FF2WS	FF3WS
Pumps, in pcs			
Monitors:			
water monitors, in pcs	4	3	2
with supply rate of each monitor, in m <sup>3</sup> /hour	2500	1200	100 <sup>1</sup> /500/1000
jet range, in m	150	120	80 <sup>1</sup> /100/120
foam monitors, in pcs	2	- <sup>2</sup>	- <sup>2</sup>
Dry powder monitors <sup>3</sup> ), in pcs	1	1	1
Distribution valve manifolds, in pcs	4	4	2
<sup>1</sup> The smaller value is for ships referred to in <b>6.6.8.2</b> .			
<sup>2</sup> A necessity in installation and characteristics to be indicated by the customer in accordance with the requirements of <b>6.6.9.2</b> .			
<sup>3</sup> For ships referred to in <b>6.6.10.1</b> .			

**6.6.5** The equipment of special systems (pumps, fittings, monitors) may be remote-controlled from the fire and rescue operations control station.

Air-operated and hydraulic control systems shall be supplied from two independent sources of power.

Electrically driven items shall comply with the requirements of **5.1** to **5.3**, Part XI "Electrical Equipment".

**6.6.6 Water-screen system.**

**6.6.6.1** In ships having distinguishing marks **FF1WS**, **FF2WS** and **FF3WS** in the class notation, outer vertical hull surfaces, including superstructures and deckhouses, shall be protected with the water-screen system.

The water-screen system shall totally cover the ship and not impede visibility from the wheelhouse, fire and rescue operations control stations and manually operated monitor platforms.



**6.6.6.2** Doors and side scuttles of ships having distinguishing marks **FF1** or **FF2** in the class notation, which are not fitted with the above system, shall comply with the requirements of **7.2.1.10**, Part III "Equipment, Arrangements and Outfit".

**6.6.6.3** The capacity and pressure of pumps serving the system shall be sufficient to supply water through spray nozzles at a rate indicated in **3.5.2**.

**6.6.6.4** Where the system is subdivided into sections, manual operation shall be provided from the place of their installation in spite of the provision of the remote control.

**6.6.6.5** The water-screen system shall protect also the manually operated monitor platforms; the system shall be put into operation directly at each monitor.

**6.6.6.6** The ship shall be fitted with water-screen system in combination with the drenching system or pressure water-spraying system, or drenching system with water discharge rate specified in **6.6.7.2** or pressure water-spraying system with water discharge rate specified in **6.6.7.2** provided they are capable to ensure adequate protection of all the outer surfaces of the ship. In any case the letters **WS** shall be retained in the class notation.

#### **6.6.7 Drenching and pressure water-spraying systems.**

**6.6.7.1** The drenching and pressure water-spraying system in ships having distinguishing marks **FF1WS**, **FF2WS** or **FF3WS** in the class notation shall protect outer vertical surfaces of the hull, superstructures and deckhouses as well as horizontal surfaces of the hull where it is appropriate with regard to **6.6.6.6**.

**6.6.7.2** The rate of water discharge to the protected surface shall be: 10 l/min per 1 m<sup>2</sup> for vertical areas (non-insulated) and 5 l/min per 1 m<sup>2</sup> for vertical areas insulated to "A-60" class;

**6.6.7.3** For protection of superstructures and deckhouses the sections of the system shall be arranged on each tier; the arrangement of spray nozzles shall ensure uniform discharge of water onto the protected outer surface. Where the system is subdivided into sections, the requirements of **6.6.6.4** shall be met.

#### **6.6.8 Special water fire extinguishing system.**

**6.6.8.1** The system is generally intended for water supply to water monitors, distribution valve manifolds, as well as for supply of water-screen and pressure water-spraying systems. The system may be used for pumping out the water from compartments of a ship in distress (refer to **7.1.10**, Part VIII "Systems and Piping").

The requirements for installation of pumps, laying of pipes, water intake arrangements, fittings and tests shall comply with the provisions of the present Part and Part VIII "Systems and Piping" as far as they are applicable and reasonable with regard to the requirements given below.

**6.6.8.2** The special water fire extinguishing system in ships having distinguishing marks **FF1**, **FF1WS**, **FF2** or **FF2WS** in the class notation shall be independent.

In ships having distinguishing mark **FF3WS** in the class notation, the ship water fire main system may be used as part of the special water fire extinguishing system.

**6.6.8.3** Availability of remote starting and control of the system shall not prevent starting of the pumps, control of monitors and fittings from the place of their installation (refer to Section 5, Part XI "Electrical Equipment"). Remote-controlled fittings shall have devices for their opening/closing during the time allowing to prevent water hammers.

**6.6.8.4** Provision shall be made for operation of pumps without overheating in case of no or small supply of water to consumers.

**6.6.8.5** The number of monitors shall be not less than that indicated in Table 6.6.3-2 and their arrangement shall: provide supply of water from each monitor to both sides of the ship; prevent water from being discharged to the ship's own deck and its equipment; provide the water jet range in accordance with Table 6.6.3-2.

**6.6.8.6** Each monitor shall have an independent connection to the main of the system.

**6.6.8.7** Distribution valve manifolds shall be arranged on the weather deck. The number of valves on the manifold shall be determined by the designer upon agreement with the customer.

**6.6.8.8** The capacity of the pumps shall be calculated so that water can be simultaneously delivered to monitors, the number of which shall comply with Table 6.6.3-2 depending on the distinguishing mark in the class notation.

#### **6.6.9 Special foam fire extinguishing system.**

**6.6.9.1** The special foam fire extinguishing system shall be provided in ships having distinguishing marks for a ship carrying equipment for fire fighting aboard other ships. The system may use totally or partly the equipment of the special water fire extinguishing system (pumps, pipes, monitors).

The number and type of the equipment of the foam fire extinguishing system shall be determined by the designer on agreement with the customer.

**6.6.9.2** Ships with distinguishing marks **FF2**, **FF2WS** or **FF3WS** in the class notation may have the system fitted with air-foam nozzles, foam generators or combination foam units, in this case foam monitors may be omitted.

**6.6.9.3** Ships with distinguishing marks **FF1** or **FF1WS** in the class notation shall be fitted with foam monitors or foam nozzles for monitors of the special water fire extinguishing system. The number of foam monitors shall be not less than that indicated in Table 6.6.3-2; the requirements for their installation shall be in line with those for monitors of the special water fire extinguishing system (refer to 6.6.8.5).

**6.6.9.4** The reserve of foam concentrate shall be calculated on the basis of the operating time of a specified number of foam generators or one monitor during at least 30 min.

**6.6.9.5** The type of foam concentrate shall be chosen with regard for water salinity in the prescribed ship service area, and class of liquids, materials or goods the concentrate is intended to extinguish (oil and petroleum products, alcohols, ketons, aldehydes, etc.).

**6.6.10 Special dry powder system.**

**6.6.10.1** The system shall be generally installed on ships servicing the operation area of gas carriers and chemical tankers.

**6.6.10.2** Applicable requirements of 3.10 also cover the special dry powder system.

**6.6.10.3** The powder rate through the monitor shall be not less than 40 kg/s. The monitor shall be placed on a special platform fitted with devices for remote starting of the system (refer to 6.6.6.5).

**6.6.10.4** The quantity of the extinguishing powder shall be determined by the designer on agreement with the customer.

**6.6.11 Fire-fighting outfit.**

**6.6.11.1** In addition to the fire-fighting outfit specified in Table 5.1.2, the following outfit shall be provided on board ships:

- fireman's outfits;
- fire hoses;
- dual-purpose manual fire nozzles;
- portable air-foam nozzles, foam generators or combination foam units;
- international shore connections;
- complete sets of fire-fighting tools;
- gas analyzers for flammable vapours and gases;
- induced-draught fans.

The number and composition of the additional fire-fighting outfit and spare parts thereto shall be determined by the designer on agreement with the customer.

**6.6.11.2** Additional fire-fighting outfit shall be kept in special storerooms.

Part of the fire-fighting outfit (hoses, hand nozzles, foam generators, air-foam nozzles, hose wrenches) may be placed at the fire stations near each distribution valve manifold.

**6.6.11.3** For charging cylinders of self-contained compressed air breathing apparatus ships shall be provided with compressors approved by competent authorities.

The capacity and the number of simultaneously charged cylinders shall be specified by the customer.

There shall be at least four charged cylinders on board the ship.

The need for a compressor to be provided on board ship may be specially considered by the Register depending on the main purpose of the ship and number of crew.

**6.6.11.4** Ships shall have two searchlights in accordance with **9.2.12**, Part III "Equipment, Arrangements and Outfit".

## **6.7 CONTAINER SHIPS AND SHIPS DESIGNED TO CARRY CONTAINERS ON OR ABOVE THE WEATHER DECK**

**6.7.1** For open-top container holds and on deck container stowage areas on container ships and other ships designed to carry containers on or above the weather deck, fire protection arrangements shall be provided for the purpose of containing a fire in the space or area of origin and cooling adjacent areas to prevent fire spread and structural damage.

**6.7.2** Container ships and other ships designed to carry containers on or above the weather deck shall carry, in addition to the equipment and arrangements required for cargo ships by Sections 3 and 5, at least one water mist lance (refer to 1.2).

**6.7.3** Ships designed to carry five or more tiers of containers on or above the weather deck shall carry, in addition to the requirements of 6.7.2, mobile water monitors as follows:

**.1** mobile water monitors shall be of an approved type and shall comply with the requirements of IMO circular MSC.1/Circ.1472;

**.2** mobile water monitors with all necessary hoses, fittings and required fixing hardware shall be kept ready for use in a location outside the cargo space area not likely to be cut-off in the event of a fire in the cargo spaces;

**.3** the mobile water monitor can be securely fixed to the ship structure ensuring safe and effective operation, and the jet reaches the top tier of containers with all required monitors and water jets from fire hoses operated simultaneously, that shall be tested during initial survey on board the ship.

**6.7.4** The number and arrangement of mobile water monitors shall comply with the following requirements:

**.1** for ships with breadth less than 30 m: at least two mobile water monitors, or ships with breadth of 30 m or more: at least four mobile water monitors;

**.2** all provided mobile water monitors can be operated simultaneously for creating effective water barriers forward and aft of each container bay;

**.3** fire hydrants for connecting mobile water monitors shall be so arranged that two jets of water required by 3.2.6.2 shall be supplied at the pressure required by 3.2.1.1;

**.4** each of the required mobile water monitors can be supplied by separate hydrants at the pressure necessary to reach the top tier of containers on deck.

**6.7.5** In cases where the mobile water monitors are supplied by separate pumps and piping system, the total capacity of the main fire pumps and the diameter of the fire main and water service pipes shall be determined in accordance with 3.2.1.7 and 3.2.5.1.

**6.7.6** in cases where the mobile water monitors are supplied by the main fire pumps; the total capacity of main fire pumps and the pipework diameter shall be sufficient for simultaneously supplying both the required number of fire hoses and mobile water monitors. However, the total capacity shall not be less than the following values, whichever is smaller:

**.1** required under 3.2.1.5.2;

**.2** 180 m<sup>3</sup>/h.

**6.7.7** In cases where the mobile water monitors and the water spraying system required for carriage of dangerous goods by 7.2.5.3, are supplied by the main fire pumps, the total capacity of the main fire pumps and the pipework diameter need only be sufficient to supply whichever of the following is the greater:

**.1** the mobile water monitors and the four nozzles required by 7.2.5.2; or

**.2** the four nozzles required by 7.2.5.2 and the water spraying system required by 7.2.5.3.

The total capacity, however, shall not be less than 6.7.6.1 or 6.7.6.2, whichever is smaller.

**6.7.8** On board container ships designed to carry five or more tiers of containers on or above the weather deck, the total capacity of the emergency fire pump need not exceed 72 m<sup>3</sup>/h.

## **6.8 SHIPS USING NATURAL GAS AS FUEL**

### **6.8.1 General.**

**6.8.1.1** Fire protection of ships using natural gas as fuel shall comply with the requirements of this Chapter in addition to the requirements of 1 - 5 depending on the ship purpose.

### **6.8.2 Structural fire protection.**

**6.8.2.1** Structures enclosing accommodation and service spaces, control stations, evacuation routes, machinery spaces facing gas fuel storage tanks located on the weather deck shall be protected by class A-60 divisions. These class A-60 divisions shall extend to the lower boundary of the wheelhouse/ deck house deck.

Structures above the enclosures, including wheelhouse/deck house windows, shall be of class A-0.

Gas fuel storage (FCS) tanks shall be isolated from the cargo and placed in accordance with the requirements of the IMDG Code (refer to 7.1.2), and shall be considered as cargo in Class 2.1 package.

**6.8.2.2** Spaces for storage of gas fuel tanks and servicing ventilation ducts shall be separated from accommodation, service, cargo and machinery spaces by fire-protecting structures of class A-60, from other spaces with low fire danger they may be separated by class A-0 fire-divisions.

Spaces, in which fuel retention system equipment is located shall be separated from category A machinery spaces and other spaces with high fire risk by a cofferdam not less than 900 mm wide, insulated

according to class A-60. If this space is adjacent to spaces with low fire risk, it is considered as category A machinery space.

For type C tanks, the gas fuel storage space can be considered as a cofferdam.

*Note:* Other spaces with a high fire risk include at least the following spaces (but not limited to):

.1 cargo spaces other than liquid fuel tanks with a flash point over 60° C and except cargo spaces for general cargo, except dangerous goods which may not be equipped with fixed fire-extinguishing systems (on passenger ships engaged on short voyages, on passenger ships with gross tonnage of less than 1000, as well as on cargo ships with gross tonnage of less than 2000 or built and intended exclusively for the carriage of ore, coal, grain, undried timber, non-combustible cargo or cargo with low fire hazard - refer to footnote <sup>10</sup> Table 3.1. 2.1.);

.2 vehicle spaces, ro-ro spaces and special category spaces;

.3 service spaces (with high fire hazard) on passenger ships carrying not more than 36 passengers, cargo ships and tankers: galley, buffet, containing hot cooking equipment; painters, cabinets, pantries with an area of 4m<sup>2</sup> and upwards; spaces where flammable liquids are stored; saunas; workshops and similar spaces not forming a part of machinery spaces; waste storage facilities and associated waste piping (refer to **2.2.1.5-1 (9)**, **2.2.1.5-2 (9)**, **2.3.3-1 (9)**, **2.3.3-2 (9)**, **2.4.2-1 (9)**, **2.4.2-2 (9)**);

.4 accommodation of high fire risk on passenger ships carrying more than 36 passengers:

public spaces with furniture and furnishings other than those with limited fire risk having a deck area of 50 m<sup>2</sup> or upwards, trade kiosks; hairdressing and beauty salons, saunas (refer to **2.2.1.3-1 (8)**, **2.2.1.3-2 (8)**).

**6.8.2.2-1** Structural fire protection of fuel containment system spaces<sup>13</sup>.

.1 The space containing the fuel containment system (refer to **2.10.1.2** Part VII «Machinery Installations») shall be separated from the machinery spaces of category A or other rooms with high fire risks. The separation shall be done by a cofferdam of at least 900 mm with insulation of A-60 class. When determining the insulation of the space containing the fuel containment system from other spaces with lower fire risks, the fuel containment system shall be considered as a machinery space of category A.

.2 For type C tanks, the fuel storage hold space (refer to **2.10.1.2** Part VII «Machinery Installations») may be considered as a cofferdam provided that:

the type C tank is not located directly above machinery spaces of category A or other rooms with high fire risk; and

the minimum distance to the A-60 boundary from the outer shell of the type C tank or the boundary of the tank connection space, if any, is not less than 900 mm.

**6.8.2.3** Gas fuel piping in weather ro-ro cargo spaces shall be protected against damage by vehicles.

**6.8.2.4** If there is more than one machinery space on board, they shall be separated by Class A-60 divisions.

**6.8.2.5** Spaces, in which fuel preparation equipment, such as pumps, compressors, heat exchangers, evaporators and pressure vessels, are located shall be considered as Category A machinery spaces, which shall be protected by a fixed fire-extinguishing system complying with the requirements of **3.1.2** taking into account the intensity of the extinguishing medium used to extinguish gas fires.

**6.8.2.6** The gas fuel reception room shall be separated from category A machinery spaces, accommodation, control stations and spaces with high fire risk by class A-60 divisions.

The fire resistance of structures separating this spaces from tanks, empty spaces, auxiliary machinery spaces of low fire or non-fire, sanitary and other similar spaces may be reduced to class A-0.

**6.8.2.7** Fuel containment spaces shall not be used to house mechanical or other fire-hazardous equipment (refer also to 6.8.2.2).

**6.8.2.8** If the machinery space, protected by the ESD system, is bounded by a single structure, it shall be of class A-60.

### **6.8.3 Water fire extinguishing system.**

**6.8.3.1** The water fire extinguishing system shall comply with the requirements of 3.2 taking into account the type of ship.

**6.8.3.2** If water fire pumps are used for the drenching system, the joint work of the water fire extinguishing system and the drenching system shall be taken into account when determining the required capacity of water fire pump.

**6.8.3.3** If the FCT is located on weather deck, shut-off valves shall be provided on the main fire main to isolate the damaged section of the pipe so that the system remains operational.

### **6.8.4 Drenching system.**

**6.8.4.1** Drenching system shall be provided to ensure fire protection and cooling of the external parts of the FCT located on the weather deck. Drenching system shall also protect the external surfaces of

superstructure, compressor and pump rooms, cargo control stations, bunkering stations and other commonly attended areas facing the FCT, located on the weather deck, if the distance between them does not exceed 10 m.

**6.8.4.2** The system shall be designed to provide the following intensities of water supply to the surface specified in **6.8.4.1**:

**.1** for horizontal surfaces - 10 l/min. per 1m<sup>2</sup>;

**.2** for vertical surfaces – 4 l/min per 1m<sup>2</sup>.

**6.8.4.3** The fire main shall be fitted with shut-off valves to disconnect its damaged sections, the distance between which shall not exceed 40 m. Instead, the system may be divided into two or more sections capable of operating independently, provided that their controls are located in one easily accessible place, access to which will not be blocked in the event of a fire in the protected spaces.

**6.8.4.4** The connection of the water fire main and the drenching system shall be made through a shut-off valve located on the open part of the deck in a protected place outside the bunkering station.

**6.8.4.5** Remote activation of drenching system pumps and remote control of valves shall be carried out from a safe, easily accessible place which cannot be cut off in the event of a fire in the protected spaces.

**6.8.4.6** Nozzles of drenching system shall be fully permeable and ensure efficient distribution of water on the protected surfaces.

#### **6.8.105 Dry powder system.**

**6.8.5.1** Dry powder system complying with the requirements of 3.10 shall be provided to protect the fuel bunkering area, including any areas of possible fuel spillage and the bunkering station. The powder rate shall be not less than 3.5 kg/s, and the quantity of the extinguishing powder shall be sufficient for its operation for at least 45 seconds.

#### **6.8.6 Fire detection alarm system.**

**6.8.6.1** Fire detection alarm system of the approved type shall be provided in the fuel containment spaces, the tank strapping and the ventilation ducts leading to them, as well as in all other spaces of fuel containment system. The fire alarm system shall provide a clear identification and location of the activated sensor.

**6.8.6.2** The smoke detection system shall not be considered as an effective and efficient means of fire detection in accordance with **6.8.6.1**, unless other means of fire detection are additionally provided.

#### **6.8.7 Fire protection outfit.**

**6.8.7.1** Two portable powder fire extinguishers with a powder content of not less than 5 kg in each shall be provided, one of which shall be located near the bunkering station.

**6.8.7.2** The engine room, in which gas heavier than air is used as fuel, shall be fitted with two portable powder fire extinguishers with a content of not less than 5 kg of powder in each, located near the entrance.

### **6.9 SHIPS CONTINUOUSLY OPERATED AT LOW TEMPERATURES.**

**6.9.1** All fire pumps, including the emergency fire pump, shall be located in spaces with a positive temperature. If the pumps of other fire-extinguishing systems using water are located independently of the pumps of the water fire extinguishing system in a separate room and are connected to their own sea connection, this sea connection shall also be protected from clogging with ice.

**6.9.2** The design of the water fire extinguishing system and foam extinguishing system shall meet the requirements of **3.2** and **3.7**, taking into account the requirements of **10.4** of Part III "Equipment, arrangement and outfit".

**6.9.3** The foamer shall be approved by the Register and stored in a space with a positive temperature.

**6.9.4** Foam generators and air-foam monitors intended for installation on ships with descriptive notation **WINTERIZATION (-40)** and **WINTERIZATION (-50)** shall be operational at the required design ambient temperature and shall be approved by the Register.

**6.9.5** Fire hoses shall meet the requirements of **5.1.4**, be approved by the Register and be suitable for operation at the design ambient temperature. It is allowed to keep fire hoses in a protected place near fire hydrants in disconnected condition.

**6.9.6** Fire extinguishers shall be located, as far as practicable, in heated rooms, protected from the effects of temperatures below freezing. If the fire extinguisher is located in a place where freezing may occur, a fire extinguisher capable of operating at the polar operating temperature shall be provided in accordance with **5.1.9.15.7**.

**6.9.7** Fireman's outfit shall be stored on board in heated spaces.

The radiotelephone shall be operational at the polar operating temperature.

### **6.10 SHIPS OPERATED IN POLAR WATERS**

#### **6.10.1 General.**

**6.10.1.1** The requirements of this Chapter are in addition to the requirements of 1 - 5 and apply to fire protection of ships intended for operation (independent navigation) in polar waters (Arctic waters and / or the Antarctic region), covered with ice, subject to the requirements of the POLAR Code.

**6.10.1.2** The requirements of this paragraph shall ensure that fire protection systems and facilities are effective and in working condition and that evacuation facilities are available so that persons on board ships can move safely and quickly for evacuation under the expected environmental conditions to the life-saving appliances embarkation deck.

**6.10.2 Functional requirements.**

**6.10.2.1** To comply with the requirements of 6.10.1.2, the following shall be provided:

- .1 all components of fire safety systems and equipment, if installed in such a way as to be exposed to the environment, shall be protected from icing and snow accumulation;
- .2 controls for local equipment and machinery shall be so arranged as to avoid freezing, icing and accumulation of snow and to be maintained at all times;
- .3 the design of fire safety systems and facilities shall take into account the need for people to be able, when required, to wear bulky outfit for protection against the cold;
- .4 means shall be provided to remove accumulated snow and ice from access points or to prevent the accumulation of snow and ice; and
- .5 fire extinguishers shall be suitable for their intended use under the expected ambient conditions.

**6.10.2.2** In addition, the following shall apply to ships intended for operation at low air temperatures:

- .1 the design of all components of fire safety systems and facilities shall be such as to ensure their readiness for use and efficiency at polar operating temperatures; and
- .2 materials used in fire protection systems exposed to the environment shall be suitable for operation at polar operating temperatures.

**6.10.3 Fire protection systems and appliances.**

**6.10.3.1** To comply with the requirements of 6.10.2.1.1, the following shall be provided:

- .1 shut-off and pressure / vacuum valves shall be protected from icing in areas
- .2 all two exposed to external influences and shall be maintained at all times; a-way portable radio equipment shall operate at polar operating temperature.

**6.10.3.2** To comply with the requirements of 6.10.2.1.2, the following shall be provided:

- .1 fire pumps, including emergency fire pumps, water mist pumps and water spray pumps, shall be located in spaces where the temperature is maintained above freezing;
- .2 the fire main shall be so arranged that areas exposed to external influences can be isolated and provided with facilities for draining such areas.

There is no need for fire hoses and hydrants to be permanently connected to the fire main, they can be stored in a protected place near fire valves;

- .3 fireman's outfit shall be stored in a warm place on the ship; and
- .4 if fixed water fire extinguishing systems are located in a space other than that for main fire pumps and use separate seawater pipes, they shall also be capable of being cleared of ice.

**6.10.3.3** In addition, for vessels designed to operate at low temperatures, the following shall apply:

- .1 portable and mobile fire extinguishers shall be located as far as practicable to meet the requirements of 6.10.2.2.1 in places protected from freezing temperatures.

Fire extinguishers capable of operating at polar operating temperatures shall be provided in places subject to freezing;

- .2 to meet the functional requirements of 6.10.2.2.1, the materials of externally exposed fire protection systems shall be approved by the Administration or a recognized organization subject to standards acceptable to IMO<sup>14</sup> or other standards that offer an equivalent level of polar working safety temperature.

**6.10.4 Alternative designs, measures and arrangements (refer to IMO Resolution MSC.386 (94)).**

Alternatively, a complete study of the design, measures and proposed arrangement may be submitted to the Register for verification according to an agreed program.

**7 SPECIAL REQUIREMENTS FOR SHIPS CARRYING PACKAGED DANGEROUS GOODS AND DANGEROUS GOODS IN BULK**

**7.1 GENERAL**

**7.1.1** The requirements of the present Section are aimed at providing additional safety measures in respect of ships carrying packaged dangerous goods and dangerous goods in bulk.

**7.1.2** For the purpose of the present Section, the following additional definitions and abbreviations have been adopted.

*INF cargo* means packaged irradiated nuclear fuel, plutonium and high-level radioactive wastes carried as cargo in accordance with Class 7 of the IMDG Code.

High-level radioactive wastes means liquid wastes resulting from the operation of the first stage extraction system or the concentrated wastes from subsequent extraction stages, in a facility for reprocessing irradiated fuel, or solids into which such liquid wastes have been converted.

*INF Code* means the International Code for the Safe Carriage of Packaged Irradiated Nuclear Fuel, Plutonium and High-Level Radioactive Wastes on Board Ships adopted by IMO resolution MSC.88(71), as amended.

*Dangerous goods* means substances, materials and products covered by the IMDG Code.

*Dangerous goods in bulk* means any materials other than liquid or gas, consisting of mixture of particles, granules or larger pieces of material, generally homogenous, covered by the IMSBC Code, and which are loaded directly into cargo spaces without the use of any intermediate package, including the same materials loaded into shipborne barges.

*Irradiated nuclear fuel* means material containing uranium, thorium and/or plutonium isotopes which has been used to maintain a self-sustaining nuclear chain reaction.

*Plutonium* means the resultant mixture of isotopes of that material extracted from irradiated nuclear fuel from reprocessing.

*Package* means cargo container established by the IMDG Code.

## **7.2 SHIPS CARRYING PACKAGED DANGEROUS GOODS OR DANGEROUS GOODS IN BULK**

**7.2.1** The requirements of the present Chapter apply to the following types of ships and cargo spaces:

.1 ships and cargo spaces not specially designed for the carriage of freight containers but intended for the carriage of packaged dangerous goods including goods in freight containers and portable tanks;

.2 purpose-built container ships and cargo spaces intended for the carriage of dangerous goods in freight containers and portable tanks (refer to 8.4.8, Part III "Equipment, Arrangements and Outfit");

.3 ro-ro ships and ro-ro cargo spaces, spaces for vehicles and special category spaces intended for the carriage of dangerous goods. A ro-ro cargo space completely open from above and on both sides may be treated as the weather deck;

.4 ships and cargo spaces intended for the carriage of dangerous goods in bulk;

.5 ships and cargo spaces intended for the carriage of dangerous goods other than liquids and gases in bulk in shipborne barges.

**7.2.2** Cargo and passenger ships shall comply with the following:

**7.2.2.1** Cargo and passenger ships including cargo and passenger ships of less than 500 gross tonnage intended for the carriage of packaged dangerous goods shall meet the requirements of this Chapter considering applicable provisions of IMO resolution MSC.269(85), Annex 2.

**7.2.2.2** Cargo ships with cargo spaces intended for the carriage of dangerous goods in bulk shall meet the requirements of this Chapter; however, these requirements for cargo ships of less than 500 gross tonnage may be reduced by the Register with an appropriate note in the Certificate of Compliance with the

<sup>14</sup> Refer to UR S6 Rev.9 (July 2018) IACS Use of Steel Blades for Various Hull Members - Ships of 90 m in Length and above or IACS URI Rev.3 (Apr. 2016) for polar classes.

Special Requirements for Ship Carrying Dangerous Goods, issued by the Register.

**7.2.2.3** A fixed fire extinguishing system of the type agreed with the Register shall be provided in cargo spaces of the following ships engaged in the carriage of dangerous goods:

passenger ships constructed on or after 1 September 1984;

cargo ships of 500 gross tonnage and upwards constructed on or after 1 September 1984.

**7.2.3** In addition to the requirements of this Chapter, the applicable provisions of the IMDG Code and the IMSBC Code shall be complied with.

Carriage of dangerous goods on all ships without complying with the provisions of the IMDG Code and the IMSBC Code is prohibited.

**7.2.4** Depending on the modes of carriage of dangerous goods in ships and cargo spaces specified in **7.2.1** the requirements of Table 7.2.4-1 shall apply; depending on the class of dangerous goods carried in bulk the requirements of Table 7.2.4-2 shall apply; depending on the class of dangerous goods other than those carried in bulk the requirements of Table 7.2.4-3 shall apply.

**Table 7.2.4-1**

Requirements of paragraphs	Ships and cargo spaces						
	Weather deck	Ships not specifically	Container cargo	Closed cargo	Open cargo	Ships for the carriage of	Shipborne barges
	of						

	ships and cargo spaces listed in 7.2.1.1 - 7.2.1.5	designed (refer to 7.2.1.1)	spaces (refer to 7.2.1.2)	spaces as given in 1.5.4.3.1 <sup>1</sup> (refer to 7.2.1.3)	spaces as given in 1.5.4.3.2 (refer to 7.2.1.3)	solid dangerous goods in bulk (refer to 7.2.1.4)	(refer to 7.2.1.5)
7.2.5.1	+	+	+	+	+	For application of the requirements of 7.2 to different classes of dangerous goods, refer to Table 7.2.4-2	+
7.2.5.2	+	+	+	+	+		-
7.2.5.3	-	+	+	+	+		+
7.2.5.4	-	+	+	+	+		+
7.2.6	-	+	+	+	+		+ <sup>3</sup>
7.2.7	-	+	+	+	-		+ <sup>3</sup>
7.2.8.1	-	+	+ <sup>2</sup>	+	-		+ <sup>3</sup>
7.2.8.2	-	+	+ <sup>2</sup>	+	-		+ <sup>3</sup>
7.2.9	-	+	+	+	-		-
7.2.10.1	+	+	+	+	+		-
7.2.10.2	+	+	+	+	+		-
7.2.11	+	+	-	-	+		-
7.2.12	+	+	+ <sup>4</sup>	+	+		-
7.2.13	-	-	-	+ <sup>5</sup>	+		-
7.2.14	-	-	-	+	-		-
7.2.15	-	-	-	+	-	-	

<sup>1</sup>Special category spaces shall be treated as closed ro-ro cargo spaces when dangerous goods are carried.

<sup>2</sup> In special cases where the barges are capable of containing flammable vapours or alternatively if they are capable of discharging flammable vapours to a safe space outside the barge carrier compartment by means of ventilation ducts connected to the barges, these requirements may be reduced or waived, which is subject to special consideration by the Register.

<sup>3</sup> For classes 4 and 5.1 solids not applicable to closed freight containers. For classes 2, 3, 6.1 and 8 when carried in closed freight containers, the ventilation rate may be reduced to not less than two air changes per hour. For classes 4 and 5.1 liquids when carried in closed freight containers, the ventilation rate may be reduced to not less than two air changes per hour. For the purpose of this requirement, a portable tank is a closed freight container.

<sup>4</sup> Applicable to decks only.

<sup>5</sup> Applies only to closed cargo spaces as given in 1.5.4.3.1, not capable of being sealed.

Note. Wherever + appears in the table, it means that this requirement is applicable to all classes of dangerous goods as given in the appropriate line of Table 2.8.2-3, except as indicated in the footnotes

**Table 7.2.4-2**

Requirements of paragraphs	Class of dangerous goods						
	4.1	4.2	4.3 <sup>1</sup>	5.1	6.1	8	9
7.2.5.1	+	+	-	+	-	-	+
7.2.5.2	+	+	-	+	-	-	+
7.2.6	+	+ <sup>2</sup>	+	+ <sup>3</sup>	-	-	+ <sup>3</sup>
7.2.7	-	+ <sup>2</sup>	+	-	-	-	-
7.2.8.1	+ <sup>4</sup>	+ <sup>2</sup>	+	+ <sup>2,4</sup>	-	-	+ <sup>2,4</sup>
7.2.8.2	+	+	+	+	+	+	+
7.2.10	+	+	+	+	+	+	+
7.2.12	+	+	+	+ <sup>2</sup>	-	-	+ <sup>5</sup>

<sup>1</sup>The hazards of substances in this class which may be carried in bulk are such that special consideration shall be given to the construction and equipment of the ship involved in addition to meeting the requirements of this table.

<sup>2</sup>Only applicable to oilcake containing solvent extractions, ammonium nitrate and ammonium nitrate fertilizers.



<sup>3</sup>Only applicable to ammonium nitrate and ammonium nitrate fertilizers. However, the degree of protection in accordance with the standards contained in the International Electrotechnical Commission, publication 60079 - Electrical Apparatus for Explosive Gas Atmospheres, is sufficient.

<sup>4</sup>Only suitable wire mesh guards are required.

<sup>5</sup>The requirements of IMSBC Code/BC Rules are sufficient.

### 7.2.5 The following additional measures shall be taken to ensure supply of water:

**.1** the water fire main system shall ensure immediate availability of water supply at the required pressure either by permanent pressurization in the fire main or by suitably placed remote starting arrangements for the fire pumps from the locations referred to in **3.2.3.9**;

**.2** the water fire main system shall ensure the delivery of the quantity of water capable of supplying four nozzles with applicators provided on board under the pressure as specified in **3.2.1.1** to any part of the cargo space when empty. Upon agreement with the Register, this amount of water may be applied by equivalent means.

The number and arrangement of fire hydrants shall be such that at least two water jets out of four required can be delivered through fire hoses of standard length to any part of the empty cargo space and that all the four jets can be delivered through hoses of standard length to any part of cargo ro-ro space;

**.3** the water fire main system shall effectively cool a cargo space by a pressure water-spraying system with a rate of water supply specified in **3.4.2.1** or by flooding (refer to 3.6.4).

Hoses capable to ensure the delivery of the required quantity of water may be used for this purpose in small spaces and in small areas of larger cargo spaces on agreement with the Register.

The drainage and pumping arrangements shall be such as to prevent the build-up of free surfaces as specified in **7.14.2**, Part VIII "Systems and Piping".

If this is impossible a calculation shall be made to prove that the ship with the cargo space flooded with water complies with the requirements of Sections **2** and **3**, Part V "Subdivision";

**.4** in lieu of compliance with the requirements of **7.2.5.3** the high expansion foam system may be used in accordance with **3.7.3** using a supply rate and time of continuous supply according to Table 3.7.1.3 for machinery or by other special suitable extinguishing media;

**.5** the total required quantity of water shall satisfy the requirements of **7.2.5.2** and **7.2.5.3**, if applicable, simultaneously calculated for the largest designated cargo space.

The requirements of **7.2.5.2** shall be met by the total capacity of the main fire pumps not including the capacity of the emergency fire pump, if fitted.

If a drencher system is used to satisfy the requirements of **7.2.5.3**, the drencher pump shall also be taken into account in this total capacity calculation;

**.6** the pressure water-spraying system required in accordance with 9.2, 9.3 and 9.4 of IMO circular MSC/Circ.608/Rev.1 "Interim Guidelines for Open-Top Containerships" also satisfies the requirements for dangerous goods. The quantity of water required to fire fighting in the largest cargo space shall be capable to ensure simultaneous operation of the pressure water-spraying system and four jets from fire nozzles.

**Table 7.2.4-3**

Requirements of paragraphs	Class of dangerous goods											
	1.1-1.6	1.4S	2.1	2.2	2.3		3		4.1	4.2	4.3	
					e	f	b	c			a	d
<b>1</b>	<b>2</b>	<b>3</b>	<b>4</b>	<b>5</b>	<b>6</b>	<b>7</b>	<b>8</b>	<b>9</b>	<b>10</b>	<b>11</b>	<b>12</b>	<b>13</b>
7.2.5.1	+	+	+	+	+	+	+	+	+	+	+	+
7.2.5.2	+	+	+	+	+	+	+	+	+	+	+	+
7.2.5.3	+	-	-	-	-	-	-	-	-	-	-	-
7.2.5.4	+	-	-	-	-	-	-	-	-	-	-	-
7.2.6	+	-	+	-	+	-	+	-	-	-	+ <sup>6</sup>	-
7.2.7	+	+	+	+	-	+	+	+	+	+	+	+
7.2.8.1	-	-	+	-	-	+	+	-	+ <sup>1</sup>	+ <sup>1</sup>	+	+
7.2.8.2	-	-	+	-	-	-	+	-	-	-	-	-
7.2.9	-	-	-	-	-	-	+	-	-	-	-	-
7.2.10	-	-	+	+	+	+	+	+	+	+	+	+
7.2.11	-	-	-	-	-	-	+	+	+	+	+	+
7.2.12	+ <sup>3</sup>	-	+	+	+	+	+	+	+	+	+	+

7.2.13	+	+	+	+	+	+	+	+	+	+	+	+
7.2.14	+	+	+	+	+	+	+	+	+	+	+	+
7.2.15	+	+	+	+	+	+	+	+	+	+	+	+

Requirements of paragraphs	Class of dangerous goods										
	5.1	5.2 <sup>5</sup>	6.1				8				9
			<i>b</i>	<i>c</i>	<i>a</i>	<i>d</i>	<i>b</i>	<i>c</i>	<i>a</i>	<i>d</i>	
<b>1</b>	<b>14</b>	<b>15</b>	<b>16</b>	<b>17</b>	<b>18</b>	<b>19</b>	<b>20</b>	<b>21</b>	<b>22</b>	<b>23</b>	<b>24</b>
7.2.5.1	+	+	+	+	+	+	+	+	+	+	+
7.2.5.2	+	+	+	+	+	+	+	+	+	+	-
7.2.5.3	-	-	-	-	-	-	-	-	-	-	-
7.2.5.4	-	-	-	-	-	-	-	-	-	-	-
7.2.6	-	-	+	-	-	-	+	-	-	-	+ <sup>8</sup>
7.2.7	+	-	+	+	+	+	+	+	+	+	-
7.2.8.1	+ <sup>1</sup>	-	+	+	-	+ <sup>1</sup>	+	+	-	-	+ <sup>1</sup>
7.2.8.2	-	-	+	-	-	-	+	-	-	-	+ <sup>8</sup>
7.2.9	-	-	+	+	+	-	+	+ <sup>9</sup>	+ <sup>9</sup>	-	-
7.2.10	+	+	+	+	+	+	+	+	+	+	+ <sup>2</sup>
7.2.11	+	-	+	+	-	-	+	+	-	-	-
7.2.12	+ <sup>4</sup>	+	+	+	-	-	+	+	-	-	-
7.2.13	+	+	+	+	+	+	+	+	+	+	+
7.2.14	+	+	+	+	+	+	+	+	+	+	+
7.2.15	+	+	+	+	+	+	+	+	+	+	+

<sup>1</sup>When "mechanically ventilated" spaces are required by the IMDG Code.

<sup>2</sup>As appropriate to the goods being carried.

<sup>3</sup>In all cases cargoes shall be stowed 3 m horizontally away from the machinery space boundaries.

<sup>4</sup>Refer to the IMDG Code.

<sup>5</sup>Stowage of class 5.2 dangerous goods under deck or in enclosed ro-ro spaces is prohibited.

<sup>6</sup>Applicable only to cargoes specified in the IMDG Code and having a flash point lower than 23°C.

<sup>7</sup>According to provisions of the IMDG Code, stowage of class 2.3 cargoes featuring additional dangerous properties of class 2.1 goods under deck or in enclosed ro-ro spaces is prohibited.

<sup>8</sup>Applicable only to cargoes specified in the IMDG Code and releasing flammable vapours.

<sup>9</sup>Applicable only to cargoes featuring additional dangerous properties of class 6.1 goods.

Symbols: *a*) liquids; *b*) liquids (<23°C); *c*) liquids (≥23°C ≤60°C); *d*) solids; *e*) flammables; *f*) non-flammables.

**7.2.6** Electrical equipment shall comply with the requirements of **2.9.2**, **2.9.3**, **2.9.9**, **2.9.10**, **2.9.12**, **16.8.1.6**, **16.8.4.5**, **16.8.6.1** and **19.11**, Part XI "Electrical Equipment".

Any other equipment which may constitute a source of ignition of explosive mixtures of vapours, gases or dust with air shall not be permitted in cargo spaces.

**7.2.7** Ro-ro cargo spaces shall be fitted with a fixed fire detection and fire alarm system complying with the requirements of **4.2.1**. All other types of cargo spaces shall be fitted either with a fixed fire detection and fire alarm system complying with the requirements of **4.2.1** or sample extraction smoke detection system complying with the requirements of **4.2.1.6**.

If a sample extraction smoke detection system is fitted, particular attention shall be given to the requirements of **4.2.1.6.3** to prevent leakage of toxic smoke into areas where people stay.

**7.2.8** Ventilation of cargo spaces shall comply with the following requirements of Part VIII "Systems and Piping":

**.1** arrangement of the ventilation system, with the requirements of **12.1.7**, **12.1.8**, **12.7.1**, **12.7.3** and **12.7.5**. For bulk cargoes of class **4.3**, as well as oilcake, which contain solvents that extract the oil, additionally with the requirements of **12.7.7**;

**.2** construction of ventilation fans, with the requirements of **12.7.4**;

**.3** natural ventilation system in compliance with the requirements of **12.7.2** shall be provided in enclosed cargo spaces intended for the carriage of dangerous goods in bulk unless not fitted with mechanical ventilation.

7.2.9 The bilge system of cargo spaces shall comply with the requirements of 7.14.1, 7.14.4 - 7.14.9 Part VIII "Systems and Piping".

7.2.10 Ships shall be provided with the following outfit:

.1 four full sets protective clothing resistant to chemical exposure and intended for use in emergency situations. The protective clothing shall cover all skin so that no part of the body is unprotected and, subject to cargo characteristics, shall meet the recommendations of the IMDG Code, the IMSBC Code/BC Rules;

.2 at least two self-contained breathing apparatus in addition to those required by item 10 of Table 5.1.2.

Two spare charges or two spare breathing apparatus shall be provided in addition to those required for the fireman's outfit (refer to 5.1.15.2).

7.2.11 Portable fire extinguishers with a total capacity of at least 12 kg of dry powder or equivalent shall be provided for cargo spaces. These extinguishers shall be in addition to any portable fire extinguishers required by the present Part.

7.2.12 Bulkheads forming boundaries between cargo spaces and machinery spaces of category A shall be of "A-60" class, unless dangerous goods are stowed at least 3 m horizontally away from such bulkheads. Other boundaries between such spaces shall be of "A-60" class.

When a cargo space is partially located above the machinery space of category A and bounding structures do not have the required insulation, such cargo space is unfit for carriage of dangerous goods. The same refers to areas of bare weather deck located above the machinery space of category A.

7.2.13 Each open ro-ro space having a deck above it and each space considered to be a closed ro-ro space not capable of being sealed shall be fitted with an approved manually operated fixed pressure waterspraying system which shall protect all parts of any deck and vehicle platform in such space. The Register may permit the use of any other fixed fire extinguishing system that has been shown by full-scale tests to be not less effective.

However, the drainage and pumping arrangements shall be such as to prevent free surfaces as specified in 7.14.2, Part VIII "Systems and Piping". If this is impossible, a calculation shall be made to prove that the ship with flooded cargo space meets the requirements of Sections 2 and 3, Part V "Subdivision".

7.2.14 In ships having ro-ro spaces, subdivision shall be provided between a closed ro-ro space and an adjacent open ro-ro space. The subdivision shall be such as to minimize the passage of dangerous vapours and liquids between such spaces. Alternatively, such subdivision need not be provided if the ro-ro space is considered to be a closed cargo space over its entire length and shall fully comply with the relevant special requirements of the present Chapter.

7.2.15 In ships having ro-ro spaces, subdivision shall be provided between a closed ro-ro space and the adjacent weather deck. The subdivision shall be such as to minimize the passage of dangerous vapours and liquids between such spaces. Alternatively, such subdivision need not be provided if the arrangements of the closed ro-ro spaces are in accordance with the requirements for the carriage of dangerous goods on the adjacent weather deck.

7.2.16 Cargo spaces in ships other than ro-ro ships shall not be adjacent to accommodation and service spaces, except service spaces of low fire risk referred to in 1.5.3.2.3.

7.2.17 Hatch covers of dry-cargo holds shall comply with the requirements of Part III "Equipment, Arrangements and Outfit".

### **7.3 SHIPS CARRYING PACKAGED IRRADIATED NUCLEAR FUEL, PLUTONIUM AND HIGH-LEVEL RADIOACTIVE WASTES (INF CARGO)**

7.3.1 The requirements of the present Chapter are based on the provisions of the INF Code and apply to all ships regardless of their date of build and size, including cargo ships of less than 500 gross tonnage, engaged in the carriage of INF cargo.

7.3.2 For the purpose of the present Chapter, ships carrying INF cargo are assigned to the following three classes, depending on the total activity of INF cargo which is carried on board.

Class **INF1** ship is a ship, having certificate to carry INF cargo with an aggregate activity less than 4000 TBq.

Class **INF2** ship is a ship, having certificate to carry irradiated nuclear fuel or high-level radioactive wastes with an aggregate activity less than  $2 \times 10^6$  TBq and ship which is certified to carry plutonium with an aggregate activity less than  $2 \times 10^5$  TBq.

Class **INF3** ship is a ship, having certificate to carry irradiated nuclear fuel or high-level radioactive wastes and ship which is certified to carry plutonium with no restriction of the maximum aggregate activity of the materials.

The compliance of the ship with the requirements of this Chapter shall be certified by the appropriate distinguishing mark added to the class notation in accordance with 2.2.13, Part I "Classification" and by the International Certificate of Fitness for Carriage of INF Cargo issued by the Register.

**7.3.3** In addition to the requirements of the present Chapter, the applicable provisions of the IMDG Code shall be complied with.

**7.3.4** The INF cargo which is required to be carried on Class **INF3** ships shall not be carried on passenger ships.

**7.3.5** The damage trim and stability shall comply with the requirements of 3.4.9, Part V "Subdivision".

**7.3.6** In addition to the requirements of the present Part, the ship shall be fitted with a fixed pressure water-spraying system to protect cargo spaces which shall ensure the rate of water discharge as indicated in 3.4.2.1. In Class **INF1** ships the pressure water-spraying system need not be installed provided the requirements of 7.2.5.1 and 7.2.5.2 are complied with.

**7.3.7** In Class **INF3** ships accommodation spaces, service spaces, control stations and machinery spaces of category A shall be fitted forward or aft of the cargo spaces, due regard being paid to the overall safety of the ship.

**7.3.8** The cargo spaces of the ship shall be fitted with temperature control systems complying with the requirements of 12.7.8, Part VIII "Systems and Piping".

**7.3.9** The ship hull structure shall comply with the requirements of Part II "Hull".

**7.3.10** Permanent devices shall be provided to secure packages of INF cargo within the cargo spaces. The devices shall meet the requirements of the Guidelines for the Development of the Cargo Securing Manual.

**7.3.11** The electrical equipment of systems and arrangements referred to in 7.3.6 and 7.3.8 shall comply with the requirements of Part XI "Electrical Equipment". The requirements for the emergency source of electrical power to supply these systems are set forth in Section 9, Part XI "Electrical Equipment".

**7.3.12** Depending upon the characteristics of the INF cargo to be carried and upon the design of the ship, additional arrangements and equipment for radiological protection meeting the requirements of the competent state authorities on radiological safety shall, if necessary, be provided.

**7.3.13** Every ship shall carry on board an approved shipboard emergency plan based on the Guidelines for Developing Shipboard Emergency Plans for Ships Carrying Materials Subject to the INF Code adopted by IMO resolution A.854(20).

**7.3.14** Every ship shall carry on board equipment (individual personnel protection outfit, apparatus, etc.) for use in emergency. The type and amount of such equipment depend upon the INF cargo to be carried and is specified by the shipboard emergency plan referred to in 7.3.13.

## **8 REQUIREMENTS FOR FIRE PROTECTION OF CARGO SHIPS OF LESS THAN 500 GROSS TONNAGE**

### **8.1 GENERAL, DEFINITIONS AND APPLICATION**

**8.1.1** The requirements of the present Section are aimed at ensuring the safety of cargo ships of less than 500 gross tonnage (except fishing vessels, chemical tankers and gas carriers) as regards their fire protection.

**8.1.2** The following definition has been adopted in the present Section. Gross tonnage is as defined in IMO resolution A.493(XII), calculated in accordance with the International Convention on Tonnage Measurement of Ships, 1969.

**8.1.3** The requirements of the present Section are intended to apply to new and - as far as reasonable and practicable, - to existing cargo ships of less than 500 gross tonnage.

**8.1.3.1** For ships of restricted service, the Register may reconsider the requirements specified in the present Section taking into account the service conditions of the ship and the measures for its fire safety stipulated by the ship designer on agreement with the customer.

**8.1.3.2** As to fire protection documentation, requirements of the present Rules shall be complied with considering the provisions of 8.1.3.1.

### **8.2 FIRE CONTROL PLANS**

**8.2.1** In all ships in the wheelhouse or in conspicuous positions in corridors, general arrangement plans shall be permanently exhibited, using graphical symbols that are in accordance with IMO resolution A.952(23), as amended by IMO resolution A1116(30), which show clearly for each deck:

.1 control stations;

.2 fire-resistant and fire-retarding divisions;

- .3 fire detection and fire alarm systems;
- .4 spaces protected by fixed fire extinguishing systems, indicating the location of their devices and valves controls, as well as the location of fire hydrants;
- .5 means of access to different compartments and decks indicating evacuation routes;
- .6 position of the fireman's outfits;
- .7 location and arrangement of the emergency stop for oil fuel unit pumps and for closing the valves on the pipes from oil fuel tanks;
- .8 ventilating system, including particulars of the fan control positions, the position of dampers and identification numbers of ventilating fans.

**8.2.2** Alternatively, the details required by **8.2.1** may be set out in a booklet, a copy of which shall be supplied to each officer, and one copy is at all times to be available on board in an accessible position.

**8.2.3** General arrangement plans and booklets shall be kept up to date, any alterations to the fire protection being recorded as specified in **8.2.1** and **8.2.2**.

**8.2.4** In all cargo ships greater than or equal to 150 gross tonnage, a duplicate set of general arrangement plans (refer to **8.2.1**) shall be permanently stored, and the booklet containing such plans shall be kept in a weathertight enclosure outside the deckhouse, painted red in accordance with the applicable requirements of **1.4.3**.

In ships of less than 150 gross tonnage, the duplicate set of the plans or the booklet may be omitted and the position of the booklet for the assistance of shoreside fire-fighting personnel shall be agreed with the Register.

**8.2.5** Description in general arrangement plans and booklets shall be in the official language of the flag state and in English.

For ships engaged in domestic service only, the plans and booklets may not be translated into English. Graphic symbols shall be in color.

**8.2.6** In all ships in addition to **8.2.1** and **8.2.2** general arrangement plans and booklets the instructions concerning the maintenance and operation of all the equipment and installations on board for the **fighting and containment of fire shall be kept under one cover, readily available in an accessible position.**

### **8.3 ALTERNATIVE DESIGN AND ARRANGEMENTS**

**8.3.1** Alternative design and arrangements which may be applied on ships shall comply with provisions of **1.7** (except **1.7.2.1.4**) considering the requirements of **8.3.2** and **8.3.3**.

**8.3.2** The required fire safety performance criteria for the ship or the space(s) concerned shall:

- .1 be based on fire safety objectives and the functional requirements of the present Section;
- .2 provide a degree of safety not less than that achieved when using the prescribed requirements;
- .3 be quantifiable and measurable.

**8.3.3** The engineering analysis of alternative design and arrangements shall be evaluated and approved by the Register.

A copy of the Register-approved documentation shall be carried on board the ship.

### **8.4 STRUCTURAL FIRE PROTECTION**

**8.4.1** The minimum fire integrity of bulkheads and decks separating adjacent spaces shall meet the requirements of Table 8.4.1.

Nos.	Space	Separation by	From space
1	Machinery space category	A-60	1. accommodation spaces
			2. control stations
			3. corridors
			4. stairways
			5. service spaces of high fire risk
			6. ro-ro spaces
			7. vehicle spaces
2	Machinery space category	A-0	Other than above (item 1)
3	Galley	A-0	Unless specified otherwise
4	Service spaces of high fire risk	B-15	Unless specified above (item 1)
5	Corridor. Staircase	B-0	Unless specified above (item 1)
6	Cargo spaces (other than ro-ro spaces and vehicle spaces)	A-0	Unless specified above (item 1)

7	Ro-ro spaces and vehicle spaces (except weather deck)	A-60	1. control stations 2. machinery spaces of category
8	Ro-ro spaces and vehicle spaces (except weather deck)	A-0	Unless specified above (item 1)

**8.4.1.1** Divisions used to separate spaces not mentioned in Table 8.4.1 shall be of non-combustible material.

In ships of less than 500 gross tonnage it is allowed to install non-combustible bulkheads, linings and ceilings with combustible covering at most 2 mm thick except corridors, stairway enclosures as well as control stations where thickness of covering shall not exceed 1,5 mm.

**8.4.1.2** The hull, superstructure, structural bulkheads, decks and deckhouses shall be constructed of steel or other equivalent material. For the purpose of applying the definition of steel or other equivalent material, the applicable fire exposure shall be one hour.

Ships built of materials other than steel shall be considered compliant to **8.3**.

**8.4.1.3** Stairways shall be enclosed, at least at one level, by divisions and self-closing doors or hatches.

**8.4.1.4** Stairways serving machinery spaces, accommodation spaces, service spaces or control stations shall be of steel or other equivalent material.

**8.4.1.5** Openings in "A" class divisions shall be provided with means of closing which shall be at least as effective for resisting fires as the divisions in which they are fitted which is determined in accordance with the FTP Code.

**8.4.1.6** In "A" class divisions, arrangements shall be made to prevent the transmission of heat to uninsulated boundaries at the intersections and terminal points of other structural members and penetrations by insulating the horizontal and vertical boundaries or penetrations for a distance of 450 mm either side.

**8.4.1.7** Doors shall be self-closing in way of machinery spaces of category A and galleys, except where they are normally kept closed.

**8.4.1.8** In cargo ships of less than 300 gross tonnage, storerooms for flammable materials and substances may be arranged in way of accommodation spaces, but not adjacent thereto.

Where a separate storeroom for flammable liquids is impeded, it is permissible to store them in steel ventilated lockers or cases. Such lockers or cases shall not be adjacent to the accommodation spaces and their doors shall open outwards.

All electrical equipment shall be intrinsically safe.

## 8.5 REQUIREMENTS FOR MATERIALS

**8.5.1** Except in cargo spaces or refrigerated compartments of service spaces, insulating materials shall be non-combustible.

**8.5.2** Insulating materials shall not contain asbestos.

**8.5.3** In spaces where penetration of oil products is possible, the surface of the insulation shall be impervious to oil or oil vapours.

**8.5.4** Vapour barriers and adhesives used in conjunction with insulation, as well as the insulation of pipe fittings, for cold service systems need not be of non-combustible materials, but they shall be kept to the minimum quantity practicable and their exposed surfaces shall have low flame spread characteristics.

**8.5.5** Paints, varnishes and other finishes used on exposed interior surfaces shall comply with the requirements of 2.1.1.7, 2.1.1.8.2.1, 2.1.8.2.2 and 2.1.1.8.3 accordingly as regards producing excessive quantities of smoke, toxic gases or vapours and shall be of the low flame spread type in accordance with the FTP Code.

**8.5.6** Pipes conveying oil or combustible liquids through accommodations and service spaces shall be of steel or other approved materials having regard to the fire risk.

**8.5.7** Where pipes penetrate "A" or "B" class divisions, the pipes or their penetration pieces shall be of steel or other approved materials.

**8.5.8** Primary deck coverings within accommodation spaces, service spaces and control stations shall be of an approved material which will not readily ignite or give rise to toxic or explosive hazards at elevated temperatures, as defined by the FTP Code.

**8.5.9** Materials readily rendered ineffective by heat shall not be used for overboard scuppers, sanitary discharges and other outlets where the failure of the material would give rise to the danger of flooding.

## 8.6 FIRE-FIGHTING EQUIPMENT AND SYSTEMS

**8.6.1** Fixed fire extinguishing systems where required, shall meet the requirements of the FSS Code.

**8.6.2** Machinery spaces of category A on ships with gross tonnage greater than or equal to 150 and operating in unrestricted or restricted waters, except ships for port, roadstead and coastal navigation shall be provided with an approved fixed fire extinguishing system, as specified in **8.6.1**.

**8.6.3** Fixed fire extinguishing systems not mandatory under the requirements of the present Section, but installed on board ships of less than 500 gross tonnage shall be of an approved type.

**8.6.4** Protection of paint lockers and flammable liquid lockers shall be agreed with the Register.

**8.6.5** Spare parts and instruments for fixed fire extinguishing systems shall be available on board.

The number of spare parts and instruments shall be determined and agreed with the Register.

**8.6.6** In ships of less than 150 gross tonnage where arranging a fire extinction station outside the protected spaces is hardly feasible, as well as in special cases, on ships of less than 500 gross tonnage where the volume of individual protected spaces does not exceed 100 m<sup>3</sup>, cylinders containing the fire extinguishing medium may be fitted within the protected space on condition that such stations are provided with efficient remote control for immediately starting the system from outside the protected space. The remote starting control position shall be distinctly indicated and lighted both from the main and emergency sources of electrical power.

## **8.7 WATER FIRE MAIN SYSTEM**

**8.7.1** Fire pumps, pipelines, hydrants and hoses required by the present Section shall be provided in all ships.

### **8.7.2 Number and capacity of fire pumps.**

**8.7.2.1** One main fixed fire pump with an independent power source and one portable fire pump shall be provided, and the latter shall be located considering the requirements of **8.7.2.7.1**.

For ice class ships the main fixed fire pump with an independent power source and the fire pump shall be provided, and the latter shall be fixed in compliance with the requirements of **8.7.2.7**.

**8.7.2.2** The total capacity of the main fixed fire pump, in m<sup>3</sup> /h, shall not be less than

$$Q = (0,145\sqrt{L(B+D)} + 2,17)^2 \quad (8.7.2.2)$$

where  $L$  - length of ship (refer to **1.1.3**, Part II "Hull"), in m;

$B$  = greatest moulded breadth of ship, in m;

$D$  = moulded depth to bulkhead deck amidships, in m.

The main fixed fire pump capacity need not exceed 25 m<sup>3</sup>/h.

**8.7.2.3** Relief valves shall be provided in conjunction with main fixed fire pump if the pump is capable of developing a pressure exceeding the design pressure of the water service pipes, hydrants and hoses. A pressure gauge shall be fitted on the discharge end of the main fixed fire pump.

**8.7.2.4** Sanitary, ballast, bilge or general service pumps may be accepted as fire pumps, provided that they are not normally used for pumping fuel oil.

**8.7.2.5** Portable fire pumps shall comply with the following requirements:

**.1** the pump shall be self-priming;

**.2** the pump shall be capable of maintaining a pressure sufficient to produce a jet throw of at least 12 m, or that required to enable a jet of water to be directed on any part of the engine room, whichever is the greater;

**.3** arrangements shall be provided to secure the pump at its anticipated operating position;

**.4** the pump set shall be stored in a secure, safe and enclosed space, accessible from open deck and clear of the machinery space of category A.

The room where the pump set is stored shall be illuminated from the emergency source of electrical power;

**.5** the pump set shall be easily moved and operated by two persons and be readily available for immediate use;

**.6** the pump set shall operate the pump for at least three hours.

For electric pumps, their batteries shall have sufficient capacity for three hours.

If the fuel type used for the pump set has a flash point below 60°C, further consideration to the fire safety aspects of fuel oil storage on board shall be given.

A diesel motor pump may be used as the pump set.

The power source for the pump shall be capable of being readily started in its cold condition by hand (manual) cranking or by special heating arrangements.

The diesel motor pump shall comply with the requirements of **5.1.17** (except **5.1.17.2**);

.7 the overboard suction hose shall be non-collapsible and of sufficient length, to ensure suction under all operating conditions.

A suitable strainer shall be fitted at the inlet end of the hose.

**8.7.2.6** In ships of less than 150 gross tonnage fitted with a fixed fire extinguishing system in the engine room, portable pumps may be omitted.

**8.7.2.7** Alternatively to portable fire pumps (refer to **8.7.2.5**), fixed fire pumps may be fitted, which shall comply with the following requirements:

.1 the pump, its source of power and sea connection shall be located in accessible positions, outside the compartment housing the main fixed fire pump required by **8.7.2.1**;

.2 the sea valve shall be capable of being operated from a position near the pump and be fitted below the lightship waterline;

.3 the pressure of water delivered by the pump shall be sufficient to produce a jet of water of not less than 12 m in length, at any hose nozzle of 12, 16 and 19 mm size or as near thereto as possible.

For ships of less than 150 gross tonnage, the jet of water shall be agreed with the Register in each particular case;

.4 pump is required to supply water for the fire extinguishing system in the space where the main fixed fire pump is situated, it shall be capable of simultaneously supplying water to this system and the fire main at the required rates;

.5 the pump may also be used for other suitable purposes on agreement with the Register;

.6 the room where the fire pump prime mover is located shall be illuminated from the emergency source of electrical power, and shall be well ventilated.

### **8.7.3 Fire hoses and nozzles.**

**8.7.3.1** For fire hoses, the nozzle sizes shall be 12, 16 or 19 mm or as near thereto as possible.

**8.7.3.2** For accommodations and service spaces, the nozzle size need not exceed 12 mm.

**8.7.3.3** The size of nozzles used in conjunction with a portable fire pump need not exceed 12 mm.

**8.7.3.4** All nozzles shall be of an approved type incorporating a shut-off.

Plastic fire hose nozzles may be used in accordance with **5.1.5**.

### **8.7.4 Fire main.**

**8.7.4.1** The diameter of the fire main shall be based on the required capacity of the main fixed fire pump and the diameter of the water service pipes shall be sufficient to ensure an adequate supply of water for the operation of at least one fire hose.

**8.7.4.2** Pipes of the water fire main system shall comply with all the requirements of **3.2.5.2**.

**8.7.4.3** The valves of water fire main pipes shall be located where they will not be damaged by cargo.

**8.7.4.4** Where a fixed fire pump is fitted outside the engine room, in accordance with **8.7.2.7**:

.1 an isolating valve shall be fitted on the fire main so that at all the hydrants in the ship, except that or those in the machinery space of category A, can be supplied with water;

.2 the isolating valve shall be located in an easily accessible position outside the machinery space of category A.

### **8.7.5 Pressure in the fire main.**

**8.7.5.1** When the main fixed fire pump or the fixed fire pump specified in **8.7.2.7** is delivering water through the fire main, fire hoses and nozzles specified in **8.7.3**, the pressure maintained at any hydrant shall be sufficient to produce a jet throw at any nozzle of not less than 12 m in length.

### **8.7.6 Number and position of fire hydrants.**

**8.7.6.1** For ships equal to or greater than 150 gross tonnage the number and position of hydrants shall be such that at least two jets of water not emanating from the same hydrant, one of which shall be from a single length of hose, as specified in **5.1.4.1**, may reach any part of the ship normally accessible to the crew while the ship is being navigated and any part of any cargo space when empty.

Furthermore, such hydrants shall be positioned near the accesses to the protected spaces.

**8.7.6.2** For ships less than 150 gross tonnage the number and position of the hydrants shall be such that at least one jet of water from a single length of hose, as specified in **5.1.4.1**, may reach any part normally accessible to the crew, while the ship is being navigated and any part of any cargo space when empty. Furthermore, such hydrants shall be positioned near the accesses to the protected spaces.

**8.7.6.3** At least one hydrant shall be provided in each machinery space of category A.

**8.7.6.4** An isolating valve and a standard quick-acting coupling shall be fitted at each fire hydrant.

**8.7.6.5** All exposed hydrants shall comply with the requirements of **3.2.6.1** and **3.2.6.5**.

**8.7.6.6** The hydrants shall be so placed that the fire hoses may be easily coupled to them.

**8.7.6.7** All the hydrants shall be painted red.



**8.7.7 Fire hoses.**

**8.7.7.1** Fire hoses shall be of approved non-perishable material resistant to destruction by microorganisms (rotting).

**8.7.7.2** The hoses shall be sufficient in length to project a jet of water to any of the spaces, but their length, in general, shall not exceed 18 m.

**8.7.7.3** Fire hoses in assembly with nozzles shall be stowed at hydrants or in conspicuous positions on reels or in baskets.

**8.7.7.4** Ships equal to or greater than 150 gross tonnage shall be provided with fire hoses the number of which shall be one for each 30 m length of the ship and one spare, but in no case less than three in all.

**8.7.7.5** For ships less than 150 gross tonnage, one hose shall be provided for each hydrant. In addition, one spare hose shall be provided on board.

**8.7.7.6** Unless one hose and nozzle is provided for each hydrant in the ship, there shall be complete interchangeability of hose couplings and nozzles.

**8.8 FIXED FIRE DETECTION AND FIRE ALARM SYSTEMS**

**8.8.1** An approved fixed fire detection and fire alarm system shall be installed in all machinery spaces of category A and cargo pump rooms.

**8.8.2** On agreement with the Register, buttons of manual fire alarms may be provided on board.

**8.9 FIRE-FIGHTING OUTFIT****8.9.1 Portable fire extinguishers.**

**8.9.1.1** All fire extinguishers shall be of type approved by the Register and shall comply with the requirements of **5.1.9**, except **5.1.9.3** and **5.1.9.4**.

**8.9.1.2** The extinguishing media employed shall be suitable for extinguishing fires in the compartments in which they are intended to be used.

**8.9.1.3** The extinguishers required for use in machinery spaces shall be of a type discharging foam, carbon dioxide gas, dry powder or other approved media suitable for extinguishing oil fires.

**8.9.1.4** The number of portable fire extinguishers and spaces where they shall be stowed is determined as follows:

**.1** accommodations and service spaces of ships greater than or equal to 150 gross tonnage - not less than 3 (three) fire extinguishers;

**.2** accommodations and service spaces of ships less than 150 gross tonnage - not less than 1 (one) fire extinguisher considering the applicable requirements of 8.9.1.5;

**.3** machinery spaces - 1 (one) fire extinguisher per every 375 kW of internal combustion engine power; however, their number shall be not less than 2 (two) and not more than 6 (six).

**8.9.1.5** Accommodation spaces, service spaces and control stations shall be provided with a sufficient number of portable fire extinguishers to ensure that at least 1 (one) extinguisher will be readily available for use in every compartment of the crew spaces. In any case, on ships greater than or equal to 150 gross tonnage their number shall be not less than 3 (three), except where this is impractical for very small ships, in which case 1 (one) extinguisher shall be available at each deck having accommodation or service spaces, or control stations.

**8.9.1.6** The extinguishers shall be stowed in readily accessible positions and shall be spread as widely as possible and not be grouped.

**8.9.1.7** One of the portable fire extinguishers intended for use in any space shall be stowed near the entrance to that space.

**8.9.1.8** A spare charge shall be provided for each required portable fire extinguisher that can be readily recharged on board. If this cannot be done, the same number of duplicate (additional) extinguishers of the same capacity, type and fire extinguishing capability shall be provided.

**8.9.2** 1 (one) fire blanket complying with the requirements of **5.1.13** shall be provided.

**8.9.3** All ships greater than or equal to 150 gross tonnage shall carry at least one firefighter's outfit consisting of a set of personal equipment, breathing apparatus and lifeline complying with the requirements of IMO resolution MSC.98(73).

**8.10 ADDITIONAL FIRE SAFETY MEASURES FOR OIL TANKERS**

**8.10.1** The requirements for tankers of SOLAS Chapter II-2 shall apply to oil tankers carrying crude oil and petroleum products, having a flash point not exceeding 60°C and a Reid vapour pressure which is below atmospheric pressure.

**8.10.2** Oil tankers carrying petroleum products having a flash point exceeding 60°C shall comply with the requirements of **6.3**, except **6.3.1.1**, and of **8.10.3** and **8.10.4**. The flash point shall be determined by a closed cup test using an approved flash point apparatus.

**8.10.3** Cargo area deck protection shall be carried out considering the following:

**.1** at least one mobile foam appliance shall be provided for use on the cargo tank deck including the cargo manifolds. Where the appliance is of the inductor type it shall comply with **5.1.8**.

The nozzle shall be capable of producing effective foam, suitable for extinguishing an oil fire, at the rate of at least 1,5 m<sup>3</sup>/min.

Self-contained appliances shall have a foam solution capacity of at least 135 l;

**.2** use shall be made of foam concentrate of types approved by the Register considering the requirements of **3.7.1.2**.

**8.10.4** The type of foam used shall be suitable for the cargoes to be carried.

### **8.11 SHIPS NOT FITTED WITH PROPELLING MACHINERY**

**8.11.1** Arrangements for fire protection, detection and extinction in ships not fitted with propelling machinery shall be considered by the Register taking into account the size and purpose of the ship, its operation conditions and the presence of accommodation spaces, machinery and combustible materials on board.

**8.11.2** On ships with a crew of less than 3 persons and on ships without a crew, not fitted with an autonomous source (s) of energy, which have premises, protected in accordance with the requirements of table **3.1.2.1**, the water fire-extinguishing system shall be constructed in accordance with the applicable requirements of **8.7**, except **8.7.2**, except for the requirement of **8.7.2.5** regarding the use of a portable fire pump as the main fire pump, the fire pipe shall be fitted with a connection to receive water from other sources, including from onshore systems, as appropriate.

For ships operated only near the shore berth, the Register may consider the requirements, taking into account the operating conditions of the ship and the measures for her fire protection, which are established by the ship's designer in agreement with the customer.

### **8.12 SHIPS CARRYING PACKAGED DANGEROUS GOODS OR DANGEROUS GOODS IN BULK**

**8.12.1** Ships carrying packaged dangerous goods or dangerous goods in bulk shall comply with the requirements of **7.2**.

**8.12.2** Ships carrying packaged irradiated nuclear fuel, plutonium and high-level radioactive wastes (INF cargo) shall comply with the requirements of **7.3**.

### **8.13 OIL RECOVERY SHIPS AND BILGE WATER REMOVING SHIPS**

**8.13.1** The fire protection of oil recovery ships and bilge water removing ships shall comply with the requirements of **6.4**, except the requirements for fitting of fixed deck foam fire extinguishing system, and of **8.10.2 - 8.10.4**.

**8.13.2** On vessels with a gross tonnage of less than 150, which have a main engine capacity of less than 220 kW, the use of a fire pump driven by the main engine is allowed, provided that the design of the engine-shaft-screw complex ensures the operation of this pump if the vessel is not underway.

### **8.14 SPECIAL PURPOSE SHIPS**

**8.14.1** The fire protection of special purpose ships shall be in compliance with the requirements of **6.2**.



*Veritas Register of Shipping LTD*

**Rules for Classification and Construction of Sea Going Ships**  
**Part VI**  
**Fire protection**

Veritas Register of Shipping LTD  
Office №19, Tower "A", Chavchavadze Str. №5,  
Batumi 6000, Georgia  
Tel.: +995 422 227427  
E-mail: [headoffice@vrsclass.com](mailto:headoffice@vrsclass.com)