

VERITAS REGISTER OF SHIPPING

**RULES FOR THE CLASSIFICATION AND
CONSTRUCTION OF SEAGOING SHIPS**

Part III

Equipment, arrangements and outfit



BATUMI 2024

Veritas Register of Shipping Ltd

Rules for classification and construction of seagoing ships

Part II "Equipment, Arrangements and Outfit"

These Rules developed on the basis of the Rules for classifications and constructions of seagoing ships on Ukrainian Register of Shipping with taking into account the experience of their application, changes in the applicable International conventions, Codes and Resolutions adopted by the International Maritime organization (IMO) with applicable amendments and changes in the applied resolutions of the United Nations Economic Commission for Europe and directives of the European Parliament and Council.

Rules for classification and construction of sea-going ships consist of following parts:

Part I Classification

Part II "Hull";

Part III "Equipment, Arrangements and Outfit";

Part IV "Stability";

Part V "Subdivision";

Part VI "Fire Protection";

Part VII "Machinery Installations";

Part VIII "Systems and Piping";

Part IX "Machinery";

Part X "Boilers, Heat Exchangers and Pressure Vessels";

Part XI "Electrical Equipment";

Part XII "Refrigerating Plants";

Part XIII "Materials";

Part XIV "Welding";

Part XV "Automation";

Part XVI "Structure and Strength of Fiber-Reinforced Plastic Ships";

Documents have been approved in accordance with the established approval procedure and come into force on 1st July of 2024.

The Rules are published in English. Official version of Rules for classifications and constructions of seagoing ships located on the official web site of Veritas Register of Shipping on the link <https://vrsclass.com/>

Official edition of the Veritas Register of Shipping

© Ukrainian Register of Shipping

PART III. EQUIPMENT, ARRANGEMENTS AND OUTFIT

1. GENERAL

1.1 APPLICATION

1.1.1 1 The requirements of this Part apply to equipment, arrangements and outfit of sea-going ships navigating in a displacement condition. To hydrofoil boats, air cushion vehicles, hydrogliders and other similar ships, unless expressly provided otherwise below, the requirements of this Part are applicable to the extent that is practicable and reasonable.

1.1.2 Ship's equipment, arrangements and outfit designed for special purposes (such as special anchor arrangements of dredgers, a deep-sea anchor arrangement for special purpose ships and similar arrangements) are not subject to the Register supervision.

1.1.3 The requirements of this Part apply, as far as practicable and reasonable, to floating metallic wing-walled docks, unless expressly provided otherwise. These Rules do not specify conditions for mooring of floating docks in a particular place of operation and selection of types and characteristics of the equipment, arrangements and outfit (anchor, mooring, etc.) used for this purpose.

1.1.4 This part of the Rules applies to:

.1 equipment providing effective anti-icing protection of ships having in accordance with provisions of **2.2.13**, Part I "Classification", the additional **DEICE** sign in ship's class notation;

.2 equipment providing the operation of helicopters, of ships which in accordance with the provisions of **2.2.25**, Part I "Classification", have an additional sign: **HELIDECK**, **HELIDECK-F** or **HELIDECK-H** respectively in the ship's class notation;

.3 equipment for tugs intended for escort operations;

.4 equipment of standby ships and ships for anchor handling;

.5 equipment for the long-term operation of ships at low temperatures, which, in accordance with the provisions of **2.2.30**, Part I "Classification", have an additional sign: **WINTERIZATION (DAT)** in the ship's class notation;

.6 arrangements providing the operation of Baltic ice class ships, which, in accordance with the provisions of **2.2.3.1**, Part I "Classification", have an additional sign: **IA Super**, **IA**, **IB** or **IC** respectively, in the ship's class notation;

.7 equipment of ships intended for inclusion in pushed convoys.

1.2 DEFINITIONS AND EXPLANATIONS

The definitions and explanations relating to the general terminology of these Rules are given in General Survey Regulation and Part I "Classification".

For the purpose of this Part the following definitions have been adopted.

1.2.1 Waterlines.

Damage waterlines are the waterlines of a damaged ship after flooding of corresponding separate compartments or their combinations as provided in Part V "Subdivision".

Margin line at docking is the envelope of the waterlines corresponding to the maximum permitted trims of the floating docks and dock lift ships when carrying out the docking operations.

Summer load waterline is the waterline indicated by the upper edge of the line which passes through the center of the ring of the load line mark for a ship in upright position.

Summer timber load waterline is the waterline indicated by the upper edge of the assigned summer timber load line.

Deepest load waterline is the waterline indicated by the upper edge of the assigned uppermost regional or seasonal load line, including fresh water load lines.

Deepest subdivision load waterline is the uppermost waterline at which the requirements of Part V "Subdivision" are still fulfilled.

1.2.2 Dimensions and draught of the ship.

Length of ship L is taken as 96 % of the total length on a waterline at 85 % of the least moulded depth or as the length from the fore side of the stem to the axis of the rudder stock on that waterline, if that be greater.

Where the stem contour is concave above that waterline, the length of the ship shall be measured from the vertical projection to that waterline of the aftermost point of the stem contour (above that waterline).

In ships designed with a rake of keel the waterline on which this length is measured shall be parallel to the design waterline.

Length of floating dock L is the distance measured along the pontoon deck and parallel to the base line, between the inner sides of the pontoon end bulkheads.

Moulded draught d is the vertical distance measured amidships from the top of the plate keel or from the point where the inner surface of the shell (outer surface in a ship with a non-metal shell) abuts upon the bar keel, to the summer load waterline.

Moulded depth D is the vertical distance measured amidships from the top of the plate keel, or from the point where the inner surface of the shell abuts upon the bar keel, to the top of the freeboard deck beam at side.

In ships having rounded gunwales, the moulded depth shall be measured to the point of intersection of the moulded lines of the freeboard deck and side, the lines extending as though the gunwale were of angular design.

Where the freeboard deck is stepped in the longitudinal direction and the raised part of the deck extends over the point at which the moulded depth shall be determined, the moulded depth shall be measured to a line of reference extending from the lower part of the deck along a line parallel with the raised part.

Moulded breadth B is the maximum breadth measured amidships from outside of frame to outside of frame in a ship with a metal shell and to the outer surface of the hull in a ship with a shell of any other material.

1.2.3 Superstructures, deckhouses.

Superstructure is a decked structure on the freeboard deck, extending from side to side of the ship or with the side plating not being inboard of the shell plating more than 4 % of the breadth *B*.

The superstructure may be either complete, i.e. extending over the entire ship's length *L*, or detached, i.e. extending only over a definite part of this length. Both complete and detached superstructures may be arranged either in a single or several tiers.

Deckhouse is a decked structure on the freeboard or superstructure deck which is set in from the sides of the ship for more than 4 % of the breadth *B* and has doors, windows or other similar openings in the outer bulkheads. The deckhouses may be arranged in a single or several tiers.

Trunk is a decked structure on the freeboard deck which is set in from the sides of the ship for more than 4 % of the breadth *B* and has no doors, windows or other similar openings in the outer bulkheads.

1.2.4 Tightness.

Tight under pressure head up to... is the term pertaining to closing appliances of openings, which means that under specified pressure the liquid will not penetrate through the openings inside the ship.

Weathertight is the term pertaining to closing appliances of openings in the above-water hull, which means that in any sea conditions water will not penetrate through the openings inside the ship. The above closing appliances shall undergo tests according to the requirements of 4.4.3, Appendix 1 to Part II "Hull".

It is allowed that the specialized organizations recognized by the Register carry out tests by means of the ultrasonic equipment as well as other test methods approved by the Register.

1.2.5 Decks.

Weather deck is the deck which is completely exposed to the weather from above and from at least two sides.

Upper deck is the uppermost continuous deck extending for the full length of the ship.

The upper deck may be stepped.

Raised quarter deck is the after upper part of a stepped deck, the forward lower part of which is taken as a portion of the freeboard deck.

Freeboard deck is the deck from which the freeboard is measured.

In a ship having a discontinuous deck the lowest line of this deck and the continuation of that line parallel to upper part of the deck is taken as a freeboard deck.

Superstructure deck, deckhouse top or trunk deck is the deck forming the top of a superstructure, deckhouse or trunk, respectively.

Superstructure deck or deckhouse top of the first, second, etc. tiers is the deck forming the top of the superstructure or deckhouse of the first, second, etc. tiers, counting from the freeboard deck.

Bulkhead deck is the deck up to which the main transverse watertight subdivision bulkheads are carried.

The bulkhead deck may be discontinuous, i.e. with a step or steps formed both by main transverse watertight bulkheads reaching the keel and transverse watertight bulkheads not reaching the keel.

Lower decks are the decks below the upper deck.

Pontoon deck of the dock is the deck on which the ship to be docked is fitted.

Top deck of the dock is the uppermost deck of the dock (the uppermost deck of the wing walls).

1.2.6 Perpendiculars and amidships.

Amidships is at the middle of the ship's length L .

Forward and after perpendiculars are the vertical lines passing in the centreline at the fore and after ends of the ship's length L , respectively.

1.2.7 Ships.

Type "A" ship is a ship designed to carry only liquid cargoes in bulk, and in which cargo tanks have only small access openings closed by gasketed covers tight under an appropriate inner pressure of liquid which is carried in the tanks. Furthermore, a type "A" ship shall have some other features, as defined in the Regulation 27 of the International Convention on Load Lines, 1966, as modified by the 1988 Protocol relating thereto with further amendments (LL 66/88) which permit this ship to be assigned a freeboard based on the Regulation 28 above mentioned Convention.

Type "B" ship is a ship which does not comply with the requirements regarding type "A" ships and which is assigned a freeboard based on on the Regulation 28 above mentioned Convention .

A type "B" ship may not be classified as a type "A" ship even though, as a result of her features detailed in the abovementioned Convention, a reduction in tabular freeboard is permitted up to the total difference between the values given in the abovementioned Convention.

Docklift ship is a dry cargo ship adapted to carry out cargo handling operations using the docking principle in ports and protected water areas.

1.2.8 Active means of the ship's steering (AMSS) are special propulsion and steering units and any combination of them or with the main propulsion devices, capable of producing thrust or traction force both at a fixed angle to the centreline of the ship and at a variable angle, either under all running conditions or part thereof including small and zero speed.

The active means of the ship's steering comprise steerable propellers including retractable units of all types, active rudders, vertical-axis propellers, waterjets, propellers in transverse tunnel (athwartship thrusters), separate steering nozzles and other devices of similar purpose.

Design and construction requirements to AMSS, except for separate nozzles and the steering part of the active rudders, set forth in part VII "Machinery Installations".

Requirements to AMSS of systems for dynamic positioning of mobile offshore drilling units (MODU) shall be carried out taking into account the Code for the Construction and Equipment of Mobile Offshore Drilling Units with amendments (MODU Code).

1.2.9 Steering gear.

Main steering gear is the machinery, rudder actuators, steering gear power units, if any, ancillary equipment and the means of applying torque to the rudder stock (e.g. tiller or quadrant) necessary for effecting movement of the rudder for the purpose of steering the ship under normal service conditions.

Auxiliary steering gear is the equipment other than any part of the main steering gear necessary to steer the ship in the event of failure of the main steering gear, but not including the tiller, quadrant or components serving the same purpose.

Steering gear power unit is:

in the case of electric steering gear an electric motor and its associated electrical equipment;

in the case of electrohydraulic steering gear an electric motor and its associated equipment and connected pump;

in the case of other hydraulic steering gear a driving engine and connected pump.

Power actuating system is the hydraulic equipment provided for supplying power to turn the rudder stock, comprising a steering gear power unit or units, together with the associated pipes and fittings, and a rudder actuator. The power actuating systems may share common mechanical components, i.e. tiller, quadrant and rudder stock, or components serving the same purpose.

Steering gear control system is the equipment by which orders are transmitted from the navigation bridge to the steering gear power units. Steering gear control systems comprise transmitters, receivers, hydraulic control pumps and their associated motors, motor controllers, piping and cables.

1.3 SCOPE OF SURVEY

1.3.1 General provisions on survey of ship's equipment, arrangements and outfit are given in the General Survey Regulations, appropriate VRS Technical working procedures and in Part I "Classification".

1.3.2 The following items included into ship's equipment, arrangements and outfit are subject to the survey by the Register during their manufacture:

1.3.2.1 Rudder and steering gear:

- .1 rudder stocks;
- .2 rudder blade;
- .3 steering nozzles;
- .4 rudder axles;
- .5 pintles of rudders and steering nozzles;
- .6 bushes of pintles;
- .7 fastenings of rudder stocks, rudder stock with rudder blade or steering nozzle, and also of rudder axle with sternframe (muff couplings, keys, bolts, nuts, etc.);
- .8 parts of the system of rudder stops;
- .9 rudder stock bearings;
- .10 active means of the ship's steering (only in the case specified in 2.1.4.2).

1.3.2.2 Anchor arrangement:

- .1 anchors;
- .2 chain cables or ropes;
- .3 anchor stoppers;
- .4 devices for securing and releasing the inboard end of chain cable or rope;
- .5 anchor hawse pipes.

1.3.2.3 Mooring arrangement:

- .1 mooring lines;
- .2 mooring bollards, belaying cleats, fairleaders, chocks, rollers and stoppers..

1.3.2.4 Towing arrangement:

- .1 tow lines;
- .2 towing bollards, bits, fairleaders, chocks and stoppers;
- .3 tow hooks and towing rails with fastenings for their securing to ship's hull;
- .4 towing snatch-blocks;

1.3.2.5 Masts and rigging:

- .1 metal, wooden and fiber-reinforced plastic spars;
- .2 standing ropes;
- .3 permanent attachments to masts and decks (eyeplates, hoops, etc.);
- .4 loose gear of masts and rigging (shackles, turnbuckles, etc.).

1.3.2.6 Closing appliances of openings in hull, superstructures and deckhouses:

- .1 side and deck scuttles;
- .2 doors of bow, side and stern openings in the shell plating;
- .3 doors in superstructures and deckhouses;
- .4 companion hatches, skylights and ventilating trunks;
- .5 ventilators;
- .6 manholes to deep and other tanks;
- .7 hatchway covers in dry cargo ships and tankers;
- .8 cargo tank hatchway covers in tankers;
- .9 doors in subdivision bulkheads.

1.3.2.7 Equipment of ship's spaces:

- .1 ceiling and battens in cargo holds;
- .2 exit doors from ship's spaces in escape routes;
- .3 stairways and vertical ladders;
- .4 guard rails, bulwark and gangways;
- .5 cellular guide members in the holds of container ships.

1.3.2.8 Emergency outfit:

- .1 collision mats;
- .2 tools;
- .3 materials.

1.3.2.9 Equipment for receiving helicopters:

- .1 light signals and illuminating means of the helideck;
- .2 VHF radio station for communication with helicopter;
- .3 portable VHF radio headset with headphones.

1.3.3 The Register survey of the manufacture of items specified in 1.3.2.1.7, 1.3.2.1.8, 1.3.2.5, 1.3.2.7.1,

1.3.2.7.5, 1.3.2.8.2 and 1.3.2.8.3 is confined to consideration of the relevant technical documentation.

1.3.4 For items specified in **1.3.2** (except for **1.3.2.9.3** and **1.2.3.9.4**), the following documents shall be submitted to the Register:

- .1 assembly drawing;
- .2 calculations (no approval stamps are needed);
- .3 detail drawings if parts or assemblies are not manufactured in accordance with standards and specifications approved by the Register.

For items specified in **1.3.2.9.3** and **1.2.3.9.4** the Register shall be provided with documentation in the scope of the requirements Cargo Ship Safety Radio Equipment Survey (GMDSS), VRS-TWP-ST-012.

1.3.5 Materials used for items specified in **1.3.2.1.1 ÷ 1.3.2.1.5, 1.3.2.2.1, 1.3.2.2.2, 1.3.2.4.3, 1.3.2.6.2 and 1.3.2.6.7 ÷ 1.3.2.6.9** are subject to the Register survey during manufacture.

1.3.6 The following equipment, arrangements and outfit are subject to the Register survey when the ship is under construction:

- .1 rudder and steering gear;
- .2 anchor arrangement;
- .3 mooring arrangement;
- .4 towing arrangement;
- .5 masts and rigging;
- .6 openings in hull, superstructures and deckhouses and their closing appliances;
- .7 arrangement and equipment of ship's spaces;
- .8 emergency outfit;
- .9 cellular guide members in the holds of container ships;
- .10 active means of the ship's steering (refer to **2.1.4**).

1.4 GENERAL

1.4.1 In ships intended to carry in bulk flammable liquids with the flash point 60°C and below no deck machinery shall be fitted directly on the decks being the top of cargo and fuel tanks.

In this case, the deck machinery shall be fitted on special foundations, the construction of which provides for free circulation of air underneath the machinery.

1.4.2 Towing and mooring arrangements plan containing the relevant information shall be available on board for the guidance of the master.

The information provided on the plan in respect of shipboard equipment shall include:

- type and location on the ship;
- safe working load (SWL);
- purpose (mooring/harbour towing/escort service);
- manner of applying tow line or mooring line load including limiting fleet angles.

Also the number of mooring lines together with the breaking strength of each mooring line shall be indicated on the plan.

This information shall be incorporated into the pilot card in order to provide the pilot with the proper information on harbour operations/escort service.

1.5 WORKING AND ALLOWABLE STRESSES

1.5.1 Wherever the working stresses are mentioned in the text of the present Part of the Rules, they mean equivalent stress(es) σ_{eq} , in MPa, determined by the formula

$$\sigma_{eq} = \sqrt{\sigma^2 + 3\tau^2}, \quad (1.5.1)$$

where: σ – normal stresses in the section under consideration, in MPa;

τ – shear stresses in the section under consideration, in MPa.

The strength conditions shall be checked against these stresses.

1.5.2 Allowable stresses with which the combined stresses shall be compared when verifying the strength conditions are specified in the present Part in fractions of the upper yield stress of the material used; the upper yield stress shall not be taken as more than 0,7 times the tensile strength of this material, unless expressly

provided otherwise.

1.6 MATERIALS AND WELDING

1.6.1 Steel forgings and castings, steel plates, sections and bars and also chain steel used for items specified in **1.3.2.1.1–1.3.2.1.5**, **1.3.2.1.7**, **1.3.2.2.1**, **1.3.2.2.2**, **1.3.2.4.3**, **1.3.2.6.2**, **1.3.2.6.7** and **1.3.2.6.9**, shall meet the relevant requirements of Part XIII "Materials".

Materials for other items of equipment, arrangements and outfit shall meet the requirements specified in the design documentation approved by the Register, unless expressly provided otherwise in these Rules.

1.6.2 The grades of steel plates and sections (refer to Tables 3.2.2-1 and 3.2.2-2, Part XIII "Materials") for items specified in **1.3.2.1.2** and **1.3.2.1.3**, shall be selected according to **1.2.3.1**, Part II "Hull" in the same manner as for hull structural members of category II; in this case, for ships of ice class **Ice4** and higher, Polar classes, Baltic ice classes **IA Super ÷ IC** and for icebreakers steel not lower than Grade B shall be adopted, and for rudder blades of icebreakers, not lower than Grade D. For items specified in **1.3.2.6.2** the grades of steel plates and sections of the main carrying framing members and plating of cover structures ensuring fixing of items when stowed for sea, as well as essential parts of drivers intended for opening at sea shall be selected according to **1.2.3.1**, Part II "Hull" as for hull structural members of category II.

1.6.3 Welding of structural elements of ship's equipment, arrangements and outfit shall be performed in accordance with the requirements of Part XIV "Welding"; besides, welded structures and joints of items specified in **1.3.2.6.2**, **1.3.2.6.7** and **1.3.2.6.9** shall comply with the applicable requirements of **1.7**, Part II "Hull".

1.7 DESIGN ACCELERATIONS DUE TO HEAVE OF THE SEA

1.7.1 The dimensionless, gravity related, design accelerations due to heave of the sea as described in this Chapter shall be applied when determining the loads upon equipment, arrangements and batches of cargo items carried by ships of unrestricted service and those of restricted area of navigation **R1** and **A-R1**.

With regard to ships of other areas of navigation, accelerations may be applied different from those required herein which shall be substantiated by calculations approved by the Register.

1.7.2 The dimensionless acceleration a_z due to heave, pitch and roll normal to the water planes of the ship shall be determined by the formula

$$a_z = \pm a_0 \sqrt{1 + \left(5,3 - \frac{45}{L}\right)^2 \left(\frac{x}{L} - 0,45\right)^2 \left(\frac{0,6}{C_B}\right)^{3/2}}, \quad (1.7.2-1)$$

$$\text{where: } a_0 = 0,2 \frac{V}{\sqrt{L}} + \frac{34 - 600/L}{L}; \quad (1.7.2-2)$$

V – maximum ahead speed, in knots, with the ship on summer load waterline on still water;

L – ship's length, in m;

x – longitudinal distance from the centre of gravity of equipment, arrangement or batch of cargo items in question to the aft perpendicular;

C_B – block coefficient.

a_z does not include the component of the static weight.

1.7.3 The dimensionless acceleration a_y due to transverse displacement, yaw and roll normal to the centreline of the ship shall be determined by the formula

$$a_y = \pm a_0 \sqrt{0,6 + 2,5 \left(\frac{x}{L} - 0,45\right)^2 + k_1 \left(1 + 0,6k_1 \frac{z}{B}\right)^2}, \quad (1.7.3-1)$$

where: k_1 – coefficient of stability to be determined by the formula

$$k_1 = \frac{13 \overline{GM}}{B}. \quad (1.7.3-2)$$

If k_1 as determined by Formula (1.7.3-2), is below 1,0, $k_1 = 1,0$ shall be assumed for calculating a_y ;

\overline{GM} – transverse metacentric height of loaded ship when the volume and distribution of stores are such as to yield maximum \overline{GM} , i;

B – ship's breadth, in m;

z – vertical distance, in m, from the summer load waterline to the centre of gravity of equipment, arrangement or batch of cargo items in question; z is positive above and negative below the summer load waterline.

a_y includes the component of the static weight in the transverse direction due to rolling.

1.7.4 The dimensionless acceleration a_x due to longitudinal displacement and pitch normal to the midship section plane shall be determined by the formula

$$a_x = \pm a_0 \sqrt{0,06 + k_2^2 - 0,25k_2}, \quad (1.7.4-1)$$

w: k_2 – factor determined from the formula:

$$k_2 = \left(0,7 - \frac{L}{1200} + 5 \frac{z}{L} \right) \frac{0,6}{C_B}. \quad (1.7.4-2)$$

a_x includes the component of the static weight in the longitudinal direction due to pitching.

1.7.5 When determining loads it shall be considered that the accelerations calculated using a_x , a_y and a_z act independently of each other.

2. RUDDER AND STEERING GEAR

2.1 GENERAL

2.1.1 Every ship, except for shipborne barges, shall be provided with a reliable device ensuring her steering and course-keeping facilities (refer to 2.10). Such devices may be rudder, steering nozzle, etc., approved by the Register. For non-propelled vessels of the dredging fleet with regard to the area of navigation and service conditions it may be allowed to omit such device or provide only stabilizers.

For towed barges the Register may allow installation of stabilizers.

2.1.2 The requirements of this Section apply only to ordinary streamlined rudders or steering nozzles with streamlined profiles and rigidly fixed stabilizers.

2.1.3 Steering gears may be designed compliant to IACS unified requirement (UR) S10.Rev.5.

2.1.4 Active means of the ship's steering.

2.1.4.1 The active means of the ship's steering may be both the means supplementary to the regulated minimum (refer to 2.1.1) and the main means of the ship's steering.

2.1.4.2 Taking into account the ship's purpose, design features and intended service conditions it may be permitted that the regulated steerability of the ship shall be provided at the low speed by simultaneous operation of the devices specified in 2.1.1 and the active means of the ship's steering.

In case where the AMSS are the main means of the ship's steering the regulated steerability shall be ensured under those running conditions of the ship for which the means are intended.

In any case, it shall be demonstrated by the method recognized by the Register that the steerability will not then be at least worse than that ensured in case of fulfilment of the requirements of 2.10.

2.1.4.3 3 Requirements for AMSS construction and design, exclusive of the separate steering nozzles and rudder section of the active rudders are outlined in Part VII "Machinery Installations". Requirements for AMSS used in the dynamic positioning systems of mobil offshore drilling units shall be fulfilled with consideration for the Code for the Construction and Equipment of Mobile Offshore Drilling Units with amendments (MODU Code).

2.1.5 The number of rudder pintles supporting the rudder is not regulated by the Register, except for icebreakers, Polar class ships, Baltic ice classes **IA Super** ÷ **IC** ships (refer to 2.11) and ships of ice class and higher for which this number shall be not less than that given in Table 2.1.5.

In exceptional cases, in icebreakers the number of rudders pintles indicated in Table 2.1.5 may be reduced to two provided the calculations proving the strength of the structure during the operation in appropriate ice conditions have been submitted.

In icebreakers and Polar class ships the steering nozzles shall not be fitted.

In ships of ice classes **Ice4** and **Ice5**, Baltic ice classes **IA Super** ÷ **IC** ships the arrangement of the

steering nozzle without the lower pintle in the solepiece is not permitted.

Table 2.1.5

Ice class	Number of rudder pintles
Icebreaker4, Icebreaker3, PC1÷PC3	4
Icebreaker2, Icebreaker1, PC4	3
Ice6, Ice5, PC5, PC6, IA Super	2
Ice4, PC7, IA,	1

2.1.6 Wherever the upper yield stress R_{eH} , of the material used enters into the formulae of this Section, the provisions of **1.5.2** shall be taken into account, but in all cases the upper yield stress R_{eH} of the material shall not be taken more than 390 MPa.

2.1.7 When checking the rudder or steering nozzle pintles and rudder stock bearings for surface pressure, the latter shall not exceed the values indicated in Table 2.1.7.

Table 2.1.7

Materials	Surface pressure p , in MPa	
	Water lubrication	Oil lubrication
Stainless steel or bronze against lignum vitae	2,4	–
Stainless steel or bronze against textolite or synthetic materials	On agreed manufacture's specification	–
Stainless steel against bronze or vice versa	6,9	–
Steel against white metal	–	4,4

2.1.8 In ships of ice classes **Ice5, Ice6, PC5, PC6, IA Super** the arrangement of two steering nozzles (in case of twin-screw ships) shall be verified by strength calculation as well as by taking measures to ensure protection against ice impact.

2.1.9 In ships of Polar classes, Baltic ice classes **IA** and **IA Super** and **Ice4 class** and higher the measures to ensure protection of steering nozzles against ice impact shall be submitted by the designer.

2.1.10 For passenger ships and special purpose ships carrying more than 60 persons having length of 120 m or more or having three or more main vertical zones, the steering gear shall comply with the requirements of **2.2.6.8**, Part VI "Fire Protection" (refer also to **2.2.6.7.2** of the above Part).

2.1.11 Steering room shall be:

- .1 readily accessible and, as far as practicable, separated from the machinery spaces; and
- .2 equipped with appropriate means to provide operational access to the steering gear and controls. Such means shall include handrails and lattices or other non-slip plating, which shall ensure proper working conditions in the event of hydraulic fluid leakage.

2.2. INITIAL DESIGN DATA

2.2.1 The initial design data specified in this Chapter are valid only for the choice of scantlings of ordinary rudders and steering nozzles with rigidly fixed stabilizers and cannot be used for determination of steering gear output characteristics.

Methods of determination of these characteristics are not regulated by the Register, and the relevant calculations are not subject to approval by the Register. The steering gear is checked by the Register during sea trials of the ship to make sure that the steering gear output characteristics comply with the requirements of **2.9.2, 2.9.3** and **2.9.8**.

2.2.2 Rudder force and rudder torque.

2.2.2.1 The rudder blade force F , in kN, for the ahead condition shall be determined by the formula

$$F = F_1 + F_2. \quad (2.2.2.1-1)$$

where

$$F_1 = 5,59 \cdot 10^{-3} k_1 k_2 (6,5 + \lambda)(b_1 - C_B)^2 A v^2; \quad (2.2.2.1-2)$$

$$F_2 = 0,177 k_1 (6,5 + \lambda) \frac{T}{D_p^2} A_p \quad (2.2.2.1-3)$$

where: k_1 – factor equal to:

- 1,0 for rectangular and trapezoidal rudders, except for rudders behind the rudder post;
 0,95 for semispade rudders (rudders of types I, II, VII and VIII in Fig. 2.2.4.1);
 0,89 for rudders behind the rudder post (rudders of types IV, X and XIII in Fig. 2.2.4.1);
 k_2 – factor equal to:
 1,0 for rudders operating directly behind the propeller;
 1,25 for rudders not operating directly behind the propeller;
 λ – value determined by the formula:

$$\lambda = h_p^2 / A_t, \quad (2.2.2.1-4)$$

where: h_p – mean height of the rudder blade part abaft the centreline of the rudder stock, in m;

A_t – sum of the rudder area and lateral area of the rudder horn or rudder post, if any, within the height h_p , in m². In

case of no rudder horn or rudder post, the value of A_t is taken as A in the calculations;

A – rudder area, in m²;

A_p – portion of the rudder area in the wake of the propeller when the rudder is in the non-reversed position, in m²;

b_1 – value equal to:

2,2 for rudders situated at the centreline of the ship;

2,32 for side rudders;

C_B – block coefficient with the ship on the summer load waterline;

V – maximum ahead speed with the ship on the summer load waterline, in knots;

T – propeller thrust at the speed V , in kN, (refer to 2.2.2.6);

D_p – propeller diameter, in m.

2.2.2.2 The value of the force F specified in 2.2.2.1 shall not be taken less than F_3 , in kN, determined by the formula

$$F_3 = k_3 A, \quad (2.2.2.2)$$

where: k_3 – factor equal to:

171 – for icebreakers of ice class **Icebreaker4** and Polar classes **PC1** ÷ **PC3** and Polar class;

150 – for icebreakers of ice class **Icebreaker3**;

130 – for icebreakers of ice class **Icebreaker2** and Polar class **PC4** ships;

110 – for icebreakers of ice class **Icebreaker1** and Polar class **PC5** ships;

95 – for ships of Polar class **PC6**;

75 – for ships of ice class **Ice6** and Polar class **PC7** ships;

66 – for ships of ice class **Ice5** and Baltic ice class **IA Super** ships;

53 – for ships of ice class **Ice4** and Baltic ice class **IA** ships;

18 – _ for other ships.

When the value of the force F_3 is greater than that of the force F specified in 2.2.2.1, in subsequent calculations the value of F_3 is taken instead of F and the value F_2 is taken equal to zero.

2.2.2.3 For the ahead condition the rudder torque M_t , in kN/m, shall not be taken less than determined by the formula

$$M_t = F \frac{A}{h_r} \left(0,35 - \frac{A_1}{A} \right), \quad (2.2.2.3-1)$$

where: A_1 – part of the rudder blade area forward of its centreline, in m².

For single-plate solid-cast rudders with the leading edge aft of the rudder stock centre line, A_1 is taken as the negative value of the area formed by the leading edge of the rudder blade and the rudder stock centre line.

For icebreakers, Polar class ships, Baltic ice classes **IA Super** and **IA** ships and **Ice4**, **Ice5**, **Ice6** ice class ships the rudder torque M_t , in kN·m, due to the force F_3 , specified in 2.2.2.2, shall not be taken less than determined by the formula

$$M_t = 0,35 F_3 b_r, \quad (2.2.2.3-2)$$

where: b_r – distance from the centre line to the rear edge of the rudder blade at the level of the midheight of the rudder blade, in m.

2.2.2.4 For the astern condition the rudder torque M_{as} , in kN/m, shall not be taken less than determined by the formula

$$M_{as} = k_4 \frac{A^2}{h_r} \left(0,7 - \frac{A_1}{A} \right) V_{as}^2, \quad (2.2.2.4)$$

where: k_4 – factor equal to:

0,185 – for rudders operating directly behind the propeller;

0,139 – for rudders not operating directly behind the propeller;

V_{as} – maximum specification speed of the ship for the astern condition, but not less than $0,5V$, in knots.

2.2.2.5 For the astern condition the rudder blade force F_{as} , in kN, shall be determined by the formula

$$F_{as} = M_{as} \frac{h_r}{A \left(0,7 - \frac{A_1}{A} \right)}. \quad (2.2.2.5)$$

When determining the bending moments and reactions of the supports according to the provisions of **2.2.4** – **2.2.7** for the astern condition, the force F_{as} shall be considered as the force F_1 , and the value of F_2 is then taken equal to zero.

2.2.2.6 In case reliable data are not available on the value of the propeller thrust mentioned in **2.2.2.1**, the value of T , in kN, may be determined by the formulae:

for fixed-pitch propellers

$$T = 0,0441 \left(\frac{30,6 N_e}{n H_1 \sqrt[3]{z \theta}} - n^2 D_p^4 \right); \quad (2.2.2.6-1)$$

for controllable-pitch propellers

$$T = 0,0441 \left(\frac{110 N_e}{\sqrt{(b_1 - C_B) \sqrt[3]{z}}} - n^2 D_p^4 \right); \quad (2.2.2.6-2)$$

where: N_e – nominal total output of the propulsion plant of the ship divided by the number of the propellers, in kW;

n – number of propeller revolutions per second, in s^{-1} ;

H_1 – propeller pitch at the zero thrust, in m, determined by the formula:

$$H_1 = H + \frac{0,055 D_p}{\theta + 0,3}, \quad (2.2.2.6-3)$$

where: H – design propeller pitch, in m;

θ – blade area ratio;

z – number of propeller blades.

2.2.3 Steering nozzle rudder force and torque.

2.2.3.1 The total force F , in kN, acting on the steering nozzle and stabilizer shall not be taken less than determined by the formula:

$$F = F_n + F_{st}, \quad (2.2.3.1-1)$$

where: F_n – force acting on the steering nozzle, in kN;

F_{st} – force acting on the stabilizer, in kN.

F_n and F_{st} – are determined by the formulae:

$$F_n = 9,81 \cdot 10^{-3} \rho D_n l_n V_1^2 \quad (2.2.3.1-2)$$

$$F_{st} = 9,81 \cdot 10^{-3} q m A_{st} V_1^2; \quad (2.2.3.1-3)$$

where: D_n – inner minimum steering nozzle bore, in m;

l_n – steering nozzle length, in m;

A_{st} – area of steering nozzle stabilizer, in m^2 ;

V_1 – speed, in knots, determined by the formula:

$$V_1 = V(1 - W); \quad (2.2.3.1-4)$$

where: W – average wake factor. In case reliable experimental data are not available, the wake factor may be determined by the formula:

$$W = 0,165C_B^n \sqrt[3]{\Delta/D_p} \quad (2.2.3.1-5)$$

where: C_B – block coefficient of the ship;

Δ – volume displacement, in m^3 , with the ship on summer load waterline;

n – number of propellers;

D_p – propeller diameter, in m;

V – maximum ahead speed, in knots, with the ship on summer load waterline; this speed shall not be taken less than:

20 knots for ships of Baltic ice class **IA Super** (refer to **2.11**);

18 knots for ships of Baltic ice class **IA** (refer to **2.11**);

17 knots for ships of ice classes **Ice5**;

14 knots for ships of ice classes **Ice4**;

11 knots for other ships;

p, q – coefficients determined by the formulae:

$$p = 78,4 - 55,6\sqrt{\lambda_n} + (44,0 - 33,4\sqrt{\lambda_n})C_{HB}; \quad (2.2.3.1-6)$$

$$q = 7,43 - 5,72\lambda_n + (2,82 - 2,2\lambda_n)C_{HB}; \quad (2.2.3.1-7)$$

C_{HB} being determined by the formula:

$$C_{HB} = 9,38T/(D_p^2V^2) \quad (2.2.3.1-8)$$

where: T – propeller thrust at speed V , in kN;

D_p – propeller diameter, in m;

λ_n is determined by the formula:

$$\lambda_n = l_n/D_p; \quad (2.2.3.1-9)$$

m – coefficient determined by the formula:

$$m = 4,5 - 0,12(\lambda_{st} - 5,43)^2; \quad (2.2.3.1-10)$$

λ_{st} is determined by the formula:

$$\lambda_{st} = h_{st}/l_{st}; \quad (2.2.3.1-11)$$

h_{st} – height of steering nozzle stabilizer, in m;

l_{st} – length of steering nozzle stabilizer, in m.

2.2.3.2 A point situated at the level of the longitudinal axis of the steering nozzle at the distance r_n from the steering nozzle leading edge shall be considered as a point of application of force F_n . The distance r_n , in m, shall not be less than determined by the formula

$$r_n = l_n(bk + c) \quad (2.2.3.2-1)$$

where: k – coefficient determined by the formula

$$k = l_{rs}/l_n; \quad (2.2.3.2-2)$$

l_{rs} – distance between the centre line of the rudder stock and the leading edge of the steering nozzle, in m;

b, c – coefficients determined by the formulae

$$b = 0,796 - 0,011(C_{HB} - 7,18)^2; \quad (2.2.3.2-3)$$

$$c = 0,1585 - 0,0916\sqrt{C_{HB}}. \quad (2.2.3.2-4)$$

A point situated at the level of the steering nozzle longitudinal axis at the distance r_{st} from the stabilizer leading edge shall be considered as a point of application of force F_{st} . The distance r_{st} , in m, shall not be less than determined by the formula

$$r_{st} = 0,25l_{st} \quad (2.2.3.2-5)$$

2.2.3.3 The total torque M_t , in kN·m, for the steering nozzle shall be determined by the formula

$$M_t = M_n - M_{st} \quad , \quad (2.2.3.3-1)$$

where: M_n – torque of force F_n , in kN·m;

M_{st} – torque of force F_{st} , in kN·m;

M_n and M_{st} are determined by the formulae:

$$M_n = F_n (l_{r,s} - r_n) \quad , \quad (2.2.3.3-2)$$

$$M_{st} = F_{st} (a + r_{st}) \quad ; \quad (2.2.3.3-3)$$

a – distance between the centre line of the rudder stock and the leading edge of the stabilizer, in m.

In any case, the total torque M_t for the steering nozzle shall not be taken less than the minimum value of torque M_{min} , in kN/m, determined by the formula:

$$M_{min} = \frac{28,1F_n}{p} (0,72l_n - l_{r,s}) + \frac{7,8F_{st}}{qm} (l_n - l_{r,s} + 0,5l_{st}) \quad (2.2.3.3-4)$$

2.2.4 Bending moments and reactions of supports for rudders of types I _ IV, VI _ XII and steering nozzles of type V (refer to Fig. 2.2.4.1).

2.2.4.1 The design values of the bending moments and reactions of supports shall be determined from the formulae of this Chapter depending on the types of the rudders shown in Fig. 2.2.4.1 having regard to the provisions of Table 2.2.4.1 as well as the type and location of the steering gear as specified in **2.2.4.2**.

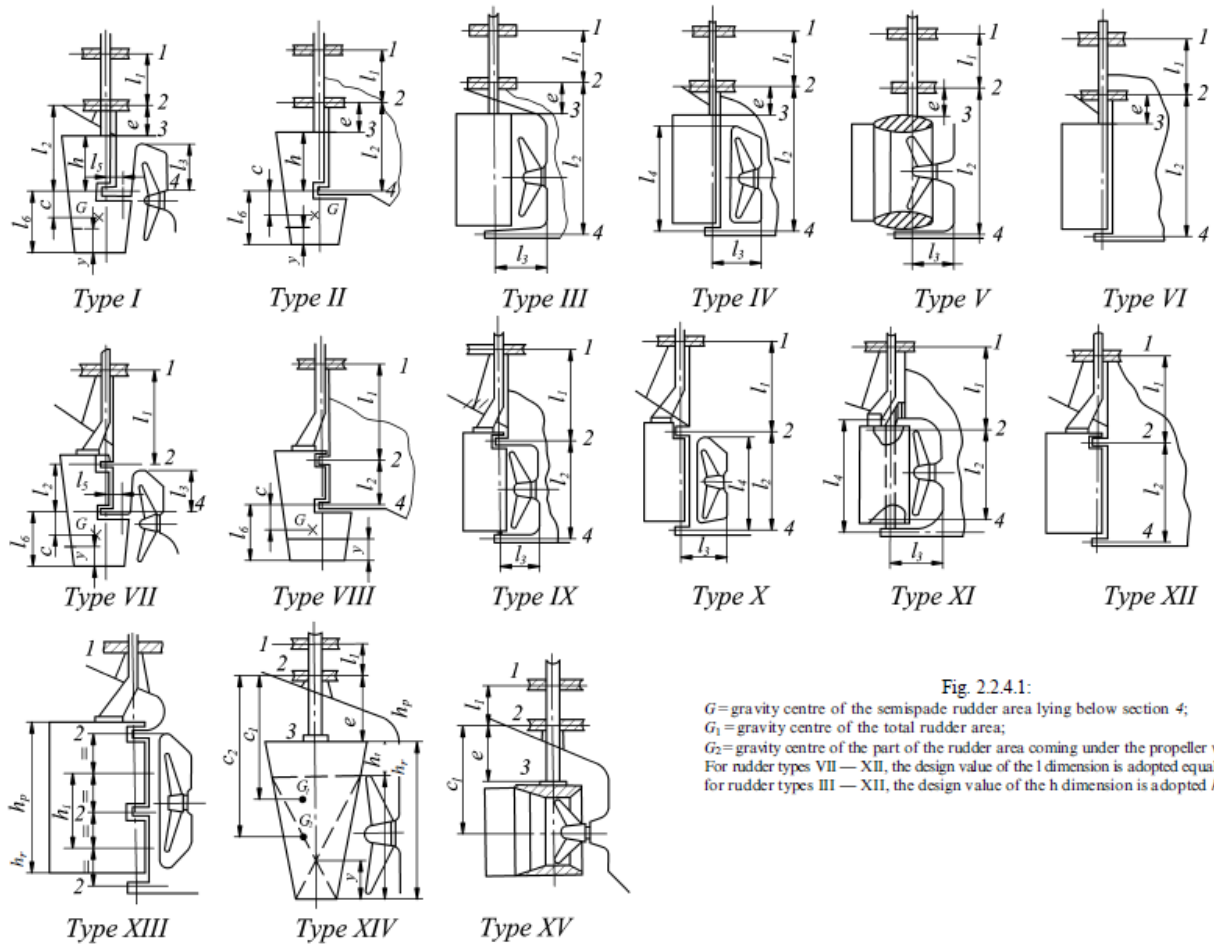

Fig. 2.2.4.1:
 G = gravity centre of the semispade rudder area lying below section 4;
 G₁ = gravity centre of the total rudder area;
 G₂ = gravity centre of the part of the rudder area coming under the propeller wash.
 For rudder types VII – XII, the design value of the l dimension is adopted equal to zero;
 for rudder types III – XII, the design value of the h dimension is adopted h = l₂ – e

Table 2.2.4.1

Type of rudder (refer to Fig. 2.2.4.1)	Design value of load Q_2	Design value of load Q_1
I, II, VII i VIII	$Q_2 = \left(\frac{F_1}{A} + \frac{F_2}{A_p} \right) A_l$	$Q_1 = F - Q_2$
III–VI i IX–XII	$Q_2 = 0$	

Notes: 1. The value of A_l is the portion the semispade rudder area below the lower pintle (below section 4 in Fig. 2.2.4.1), in m².
 2. For steering nozzles of type V the design value of the ratio $l_{r,s}/l_r$ is taken equal to zero.
 3. The force F is taken in accordance with the provisions of 2.2.2 for rudders and of 2.2.3 for steering nozzles.

2.2.4.2 The transverse force P , in kN, created on the rudder stock by steering gear (quadrant steering gears, steering gears with single-arm tillers and similar steering gears) is determined by the formula:

$$P = M_t / r_1, \tag{2.2.4.2}$$

where: M_t – rudder torque, in kN/m, specified in 2.2.2.3 and 2.2.3.3. When considering the astern running of the ship, the rudder torque M_t is taken as the value M_{as} specified in 2.2.2.4;

r_1 – radius of the steering gear quadrant or tiller resultant force arm measured from the centre line of the rudder stock, in m.

Depending on the location of the steering gear quadrant or tiller indicated in Fig. 2.2.4.2 the value P for Case I is taken as P_I and the value P_{II} is taken equal to zero. For Case II the value of P is taken as P_{II} and the value of P_I is taken equal to zero. The values of P_I or P_{II} are assumed to be positive when the quadrant or tiller are located forward of the rudder stock centre line and they are assumed to be negative when the quadrant or tiller are located aft of the rudder stock centre line.

For steering gears the rudder torque of which is transmitted to the rudder stock by a pair (or pairs) of

forces (four-piston, rotary vane steering gears or similar) the values of P_I and P_{II} are taken equal to zero.

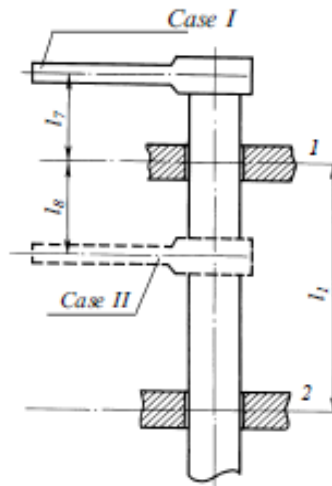

Fig

2.2.4.3 In the formulae of this Chapter the numerical indices of symbols of the bending moments (M_1 , M_2 , M_3 i M_4) and reactions of supports (R_1 , R_2 , R_3 i R_4) correspond to the number of the support or section given in Figs. 2.2.4.1 and 2.2.4.2 for the relevant type of the rudder.

2.2.4.4 Unless expressly provided otherwise, in the formulae of this Chapter the linear dimensions shown in Figs. 2.2.4.1 and 2.2.4.2 shall be taken in metres, and the forces, in kN.

2.2.4.5 The design values of the bending moments and reactions of supports may be taken less than those specified in 2.2.4.1 on condition that the detailed calculation is submitted where due consideration is given to the flexibility of the rudder supports and to the non-uniformity of the force distribution over the rudder blade area.

2.2.4.6 For Case I of the quadrant steering gear or tiller location (refer to Fig. 2.2.4.2) the design value of bending moment M_1 , in kN·m, in section 1 of the rudder stock (at the upper bearing) shall be determined by the formula:

$$M_1 = P_I l_7, \quad (2.2.4.6)$$

Where for P_I , l_7 – refer to 2.2.4.2 i 2.2.4.4.

For Case II of the steering gear quadrant or tiller location M_1 is taken equal to zero.

2.2.4.7 The design value of the bending moment M_2 , in kN·m, acting in section 2 of the rudder stock (at the lower bearing for rudders of types I - VI; in the rudder stock and rudder blade coupling for rudders of types VII - XII) shall be determined by the formula:

$$M_2 = \frac{1}{8} Q_1 h \frac{k_5}{k_7} - \frac{1}{2} Q_2 c \frac{k_6}{k_7} - \frac{1}{2} P_I l_7 \frac{k_8}{k_7} + \frac{1}{2} P_{II} l_8 \frac{k_9}{k_7}, \quad (2.2.4.7-1)$$

where: Q_1 and Q_2 – loads determined in accordance with Table 2.2.4.1;

P_I and P_{II} – forces determined in accordance with 2.2.4.2;

h , c , l_7 , l_8 – linear dimensions (refer to 2.2.4.4);

k_5 – k_9 – factors determined by the formulae:

$$k_5 = 2\left(\frac{e}{h}\right)^2\left(3 + \frac{e}{h}\right) + \left(1 + 5\frac{e}{h}\right)\frac{l_{r,s}}{l_r} + 12\left(1 + 2\frac{e}{h}\right)\frac{l_{r,s}^2 a_4}{h^3}, \quad (2.2.4.7-2)$$

$$k_6 = \left(\frac{e}{h}\right)^2\left(3 + \frac{e}{h}\right) + \left(1 + 3\frac{e}{h}\right)\frac{l_{r,s}}{l_r} - 6\left(1 + \frac{l_7}{c}\right)\frac{l_{r,s}^2 a_4}{h^3}, \quad (2.2.4.7-3)$$

$$k_7 = \left(1 + \frac{e}{h}\right)^2\left(1 + \frac{e}{h} + \frac{l_1}{h}\right) - 1 + \frac{l_{r,s}}{l_r} + 3\frac{l_{r,s}^2 a_4}{h^3}, \quad (2.2.4.7-4)$$

$$k_8 = l_1 l_2^2 / h^3; \quad (2.2.4.7-5)$$

$$k_9 = \frac{l_1 l_2^2}{h^3} \left(1 - \frac{l_8^2}{l_1^2} \right), \quad (2.2.4.7-6)$$

where: e , l_1 and l_2 – linear dimensions (refer to 2.2.4.4);

$I_{r,s}$ – mean moment of inertia of the rudder stock cross-section, in cm^4 ;

I_r – mean moment of inertia of the rudder cross-section at the portion between sections 3 - 4 (rudder types I - VI) or between sections 2 - 4 (rudder types VII - XII), in cm^4 ;

α_4 – coefficient determined in accordance with the provisions of 2.2.4.17, 2.2.4.18, 2.2.4.19, 2.2.4.20 or 2.2.4.21 depending on the type of the rudder, in m^3/cm^4 .

2.2.4.8 The design value of the bending moment M_3 , in $\text{kN}\cdot\text{m}$, acting in section 3 of the rudder stock (in the rudder stock and rudder blade coupling for rudders of types I to VI) shall be determined by the formula

$$M_3 = M_2 \frac{h}{l_2} + Q_2 c \frac{e}{l_2} - \frac{1}{2} Q_1 h \frac{e}{l_2}. \quad (2.2.4.8)$$

2.2.4.9 The design value of the bending moment M_4 , in $\text{kN}\cdot\text{m}$, acting in section 4 of the rudder blade for rudders of types I, II, VII and VIII shall be determined by the formula

$$M_4 = Q_2 c. \quad (2.2.4.9)$$

For rudders of these types the value of M_4 is taken as the bending moment acting in any rudder cross-section above support 4 of the rudder.

For other rudders the value of the bending moment M_4 is taken equal to zero.

2.2.4.10 The design value of the reaction R_1 in kN , of support 1 of the rudder (of the upper bearing) shall be determined by the formula

$$R_1 = \frac{M_2}{l_1} - P_1 \left(1 + \frac{l_7}{l_1} \right) - P_{II} \left(1 - \frac{l_8}{l_1} \right) \quad (2.2.4.10)$$

2.2.4.11 The design value of the reaction R_2 , in kN , of support 2 of the rudder (of the lower bearing for rudder types I – VI, of the upper bearing of the rudder axle for rudder type XI, of the upper pintle of rudders for types VII – X and XII) shall be determined by the formula

$$R_2 = -M_2 \left(\frac{1}{l_1} + \frac{1}{l_2} \right) + Q_2 \frac{c}{l_2} - \frac{1}{2} Q_1 \frac{h}{l_2} + P_1 \frac{l_7}{l_1} - P_{II} \frac{l_8}{l_1}. \quad (2.2.4.11)$$

2.2.4.12 The design value of the reaction R_4 , in kN , of support 4 of the rudder (of the lower pintle) shall be determined by the formula

$$R_4 = \frac{M_2}{l_2} - \frac{1}{2} Q_1 \left(1 + \frac{e}{l_2} \right) - Q_2 \left(1 + \frac{c}{l_2} \right). \quad (2.2.4.12)$$

2.2.4.13 The design value of the bending moment M_r , in $\text{kN}\cdot\text{m}$, acting in the considered section of the lower part of the semispade rudder body (below section 4 shown in Fig. 2.2.4.1 for rudder types I, II, VII and VIII) shall be determined by the formula

$$M_r = \frac{1}{2} Q_2 \frac{y^2}{k_6}, \quad (2.2.4.13)$$

where: y and l_6 – linear dimensions (refer to 2.2.4.4).

2.2.4.14 The design value of the bending moment M_r , in kN·m, acting in any cross-section of the rudder blade for rudders of types III, IV, VI and IX – XII shall be determined by the formula:

$$M_r = \frac{1}{2} M_2 \frac{h}{l_2} \left(2 - \frac{h}{l_2} - \frac{M_2}{Q_1 l_2} \right) - \frac{1}{8} Q_1 h \left(2 - \frac{h}{l_2} \right)^2 \quad (2.2.4.14)$$

2.2.4.15 The design value of the bending moment M_{ra} , in kN·m, acting in the section of the rudder axle near its flange shall be determined by the formula:

$$M_{ra} = R_4 l_4 \left[0,42 \frac{(l_4 - l_2)}{l_4} + 0,24 \frac{l_3 I_{rp}}{l_4 I_s} + 0,15 \left(\frac{l_3}{l_4} \right)^2 \right] \quad (2.2.4.15)$$

where: l_3 and l_4 – linear dimensions (refer to 2.2.4.4);

I_{rp} – mean moment of inertia of the rudder axle or rudder post cross-section, in cm⁴;

I_s – mean moment of inertia of the solepiece cross-section, in cm⁴.

2.2.4.16 For Case II of the steering gear quadrant or tiller location (refer to Fig. 2.2.4.2) the design value of the bending moment M_s , in kN·m, acting in the section of the rudder stock in way of the quadrant or tiller location shall be determined by the formula

$$M_s = R_1 I_8 \quad (2.2.4.16)$$

For Case I of the steering gear quadrant or tiller location M_s is taken equal to zero.

2.2.4.17 The coefficient α_4 in m³/cm⁴, for rudders of types I and VII (for the horn of the semispade rudder) shall be determined by the formula

$$\alpha_4 = \frac{1,07 l_3^3}{3 I_1} \left(4 - 3 \frac{b_{h0}}{b_{h1}} \right) + \frac{1,3 l_5^2 l_3}{I_2} \left(1 + \frac{b_{h1}}{b_{h0}} \right) \frac{b_{h1}}{b_{h0}} \quad (2.2.4.17-1)$$

where: l_5 – linear dimension (refer to 2.2.4.4);

I_1 – moment of inertia of the rudder horn cross-section at its root about the axis parallel to the centreline of the ship, in cm⁴;

b_{h0} – maximum width of the horizontal section of the rudder horn at the lower pintle (section 4 in Fig. 2.2.4.1), in m;

b_{h1} – maximum width of the horizontal section of the rudder horn at its root, in m;

I_2 – polar moment of inertia of the rudder horn cross-section at its root, in cm⁴, determined by the formula

$$I_2 = \frac{4 A_{rh}^2}{\sum_{i=1}^n l_{0i} / s_{0i}} \quad (2.2.4.17-2)$$

where: A_{rh} – area enclosed by the centre line of the rudder horn plating (with the cross-section at the horn root), in cm²;

l_{0i} – length of the centre line of the rudder horn plating (in the cross-section at the horn root) of the given thickness, in cm;

s_{0i} – thickness of the considered portion of the rudder horn plating with the length l_{0i} , in cm;

n – number of portions of the rudder horn plating with the length l_{0i} and thickness s_{0i} .

2.2.4.18 The coefficient α_4 in m³/cm⁴, for rudders of types III, V and IX (for the solepiece) shall be determined by the formula

$$\alpha_4 = \frac{l_3^3}{3 I_{s1}} \left(4 - 3 \frac{b_{s0}}{b_{s1}} \right) \quad (2.2.4.18)$$

where: I_{s1} – moment of inertia of the solepiece cross-section at its root about the vertical axis, in cm⁴;

b_{s0} – width of the solepiece cross-section at the rudder stock or steering nozzle pintle, in cm;

b_{sl} – width of the solepiece cross-section at its root, in cm.

2.2.4.19 The coefficient α_4 in m^3/cm^4 , for rudders of types IV and X (for the rudder post with the solepiece) shall be determined by the formula

$$\alpha_4 = \frac{l_3^3}{3I_s} \left(0,075 \frac{I_s}{I_{rp}} + 0,334 \frac{l_4}{l_3} \right) \quad (2.2.4.19)$$

2.2.4.20 The coefficient α_4 in m^3/cm^4 , for rudder of type XI (for rudder axle with the solepiece) shall be determined by the formula

$$\alpha_4 = \frac{l_3^3}{3I_s} \left\{ \left(0,075 \frac{I_s}{I_{rp}} + 0,334 \frac{l_4}{l_3} \right) - 0,282 \frac{(l_4 - l_2)}{l_4} \times \left[1,55 \frac{l_4}{l_3} + 0,053 \left(\frac{l_4}{l_3} \right)^2 + \frac{(l_4 - l_2)}{l_4} \frac{I_s}{I_{rp}} \right] \right\} \quad (2.2.4.20)$$

2.2.4.21 The coefficient α_4 for rudders of types II, VI, VIII and XII is taken equal to zero.

2.2.5 Bending moments and reactions of supports for rudder of type XIII (refer to Fig.2.2.4.1).

2.2.5.1 The requirements of **2.2.4.2 - 2.2.4.6** and **2.2.4.16** are also applicable to the rudders of type XIII.

2.2.5.2 The design value of the bending moment acting in way of the rudder stock and rudder blade coupling shall be taken equal to zero.

2.2.5.3 The design value of the bending moment M_r , in $\text{kN}\cdot\text{m}$, acting in any cross-section of the rudder blade shall be determined by the formula

$$M_r = 0,1 F h_i^2 / h_r, \quad (2.2.5.3)$$

where: F – force determined according to the provisions of **2.2.2.1**, **2.2.2.2** and **2.2.2.5**, in kN ;

h_i and h_r – linear dimensions (refer to 2.2.4.4); in this case, the greater of the value h_i shall be taken as the design value.

2.2.5.4 The design value of the reaction R_1 of support 1 of the rudder (of the upper bearing) shall be taken equal to zero.

2.2.5.5 The design value of the reaction R_2 in kN , of support 2 of the rudder (of any pintle) shall be determined by the formula

$$R_2 = F h_i / h_r. \quad (2.2.5.5)$$

2.2.6 Bending moments and reactions of supports for rudder of type XIV (refer to Fig. 2.2.4.1).

2.2.6.1 The requirements of **2.2.4.2 - 2.2.4.6** and **2.2.4.16** are also applicable to the rudders of type XIV.

2.2.6.2 The design value of the bending moment M_2 , in $\text{kN}\cdot\text{m}$, acting in section 2 of the rudder stock (at the lower bearing) shall be determined by the formula

$$M_2 = F_1 c_1 + F_2 c_2, \quad (2.2.6.2)$$

where: F_1 and F_2 – forces determined according to the provisions of **2.2.2.1**, **2.2.2.2** and **2.2.2.5**, in kN ;

c_1 і c_2 – лінійні розміри (див. **2.2.4.4**), м.

2.2.6.3 The design value of the bending moment M_3 , in $\text{kN}\cdot\text{m}$, acting in section 3 of the rudder stock (in the rudder stock and rudder blade coupling) shall be determined by the formula

$$M_3 = F_1 (c_1 - e) + F_2 (c_2 - e), \quad (2.2.6.3)$$

where: e – linear dimension (refer to **2.2.4.4**), in m.

2.2.6.4 The design value of the bending moment M_r , in $\text{kN}\cdot\text{m}$, acting in the considered section of the rudder blade shall be determined by the formulae:

for sections with $y < h_1$

$$M_r = \frac{1}{2} \left(\frac{F_1}{h_r} + \frac{F_2}{h_1} \right) y^2, \quad (2.2.6.4-1)$$

for sections with $y \geq h_1$

$$M_r = \frac{1}{2} \frac{F_1}{h_r} y^2 + F_2 \left(y - \frac{1}{2} h_1 \right), \quad (2.2.6.4-2)$$

where h_r , h_1 and y – linear dimensions (refer to 2.2.4.4), in m.

2.2.6.5 The design value of the reaction R_1 in kN, of support 1 of the rudder (of the upper bearing) shall be determined by the formula

$$R_1 = F_1 \frac{c_1}{l_1} + F_2 \frac{c_2}{l_1} - P_{I1} \left(1 + \frac{l_7}{l_1} \right) - P_{II} \left(1 - \frac{l_8}{l_1} \right), \quad (2.2.6.5)$$

where: l_1 – linear dimension (refer to 2.2.4.4), in m.

2.2.6.6 The design value of the reaction R_2 in kN, of support 2 of the rudder (of the lower bearing) shall be determined by the formula

$$R_2 = F_1 \left(1 + \frac{c_1}{l_1} \right) + F_2 \left(1 + \frac{c_2}{l_1} \right) - P_{I1} \frac{l_7}{l_1} + P_{II} \frac{l_8}{l_1}. \quad (2.2.6.6)$$

2.2.7 Bending moments and reactions of supports for steering nozzles of type XV (refer to Fig. 2.2.4.1).

2.2.7.1 The requirements of 2.2.4.2, 2.2.4.3, 2.2.4.4, 2.2.4.6 and 2.2.4.16 are also applicable to the steering nozzle of type XV.

2.2.7.2 The design value of the bending moment M_2 , in kN·m, acting in section 2 of the rudder stock (at the lower bearing) shall be determined by the formula

$$M_2 = F c_1, \quad (2.2.7.2)$$

where: F – force determined according to the provisions of 2.2.3.1, in kN;
 c_1 – linear dimension (refer to 2.2.4.4), in m.

2.2.7.3 The design value of the bending moment M_3 , in kN·m, acting in section 3 of the rudder stock (at the rudder stock and steering nozzle coupling) shall be determined by the formula

$$M_3 = F(c_1 - e), \quad (2.2.7.3)$$

where: e – linear dimension (refer to 2.2.4.4), in m.

2.2.7.4 The design value of the reaction R_1 , in kN, of support 1 (of the upper bearing) shall be determined by the formula

$$R_1 = F \frac{c_1}{l_1} - P_{I1} \left(1 + \frac{l_7}{l_1} \right) - P_{II} \left(1 - \frac{l_8}{l_1} \right), \quad (2.2.7.4)$$

where: l_1 – linear dimension (refer to 2.2.4.4), in m.

2.2.7.5 The design value of the reaction R_2 in kN, of support 2 (of the lower bearing) shall be determined by the formula

$$R_2 = F \left(1 + \frac{c_1}{l_1} \right) - P_I \frac{l_7}{l_1} + P_{II} \frac{l_8}{l_1}. \quad (2.2.7.5)$$

2.2.8 The design values of bending moments and reactions of supports for the steering gears which differ from those indicated in Fig. 2.2.4.1 shall be submitted by the designer.

2.3 RUDDER STOCK

2.3.1 The diameter of the rudder stock head d_0 , in cm, shall be not less than the greater value determined by the formula

$$d_0 = k_{10} \sqrt[3]{M_t / R_{eH}}, \quad (2.3.1)$$

where: k_{10} – factor equal to:

26,1 for the ahead condition;

23,3 for the astern condition;

M_t – torque according to **2.2.2.3**, **2.2.2.4** or **2.2.3.3**, in kN·m;

R_{eH} – upper yield stress of the rudder stock material, in MPa.

2.3.2 Under combined action of the torque and bending moment the working stresses (refer to **1.5.1**) acting in rudder stock sections 1, 2 or 3 shown in Fig. 2.2.4.1 for the appropriate type of the rudder shall not exceed 0,5 times the upper yield stress for the ahead condition and 0,7 times the upper yield stress of the material for the astern condition (refer to **1.5.2** and **2.1.6**). In this case, the normal stress (σ) and the shear stress (τ) in MPa, shall be determined by the formulae:

$$\sigma = 10,2 \cdot 10^3 M_b / d_i^3, \quad (2.3.2-1)$$

$$\tau = 5,1 \cdot 10^3 M_t / d_i^3, \quad (2.3.2-2)$$

where: M_b – bending moment acting in the considered section of the rudder stock (M_1 , M_2 or M_3), determined according to the provisions of **2.2.4** to **2.2.7** for the appropriate type of the rudder, in kN·m;

d_i – diameter of the rudder stock in the considered section, in cm.

2.3.3 The change in the rudder stock diameter between the adjacent sections specified in **2.3.1** and **2.3.2** shall not be more sudden than that permitted by the linear law.

Where the change of the rudder stock diameter is stepped, the steps shall be provided with fillets having as large radius as practicable. The transition of the rudder stock into the flange shall be carried out with a radius of fillet of not less than 0,12 times the diameter of the rudder stock in way of the flange.

2.4 RUDDER BLADE AND STEERING NOZZLE

2.4.1 Rudder blade.

2.4.1.1 The thickness of the streamlined rudder blade side plating s , in mm, shall be not less than determined by the formul

$$s = ak_{11} \sqrt{\frac{98d + k_{12} \left(\frac{F_1}{A} + k_{13} \frac{F_2}{A_p} \right)}{R_{eH}}} + 1,5, \quad (2.4.1.1-1)$$

where: d – осадка судна, м,

F_1 i F_2 – forces according to 2.2.2.1 and 2.2.2.2, in kN;

for A and A_p , refer to 2.2.2.1;

a – distance between horizontal or vertical web plates, whichever is the less, in m;

k_{11} – factor determined by the formula:

$$k_{11} = 10,85 - 2,516 \left(\frac{a}{b} \right)^2; \quad (2.4.1.1-2)$$

R_{eH} – upper yield stress of the rudder blade plating material, in MPa;

b – distance between horizontal or vertical web plates whichever is the greater, in m;

k_{12} – factor equal to:

18,6 for the rudder blade plating within 0,35 of the rudder blade length from its leading edge;

8,0 for the rudder blade plating within 0,65 of the rudder length from its rear edge;

k_{13} – factor equal to:

1 for the rudder blade plating in the wake of the propeller (when rudder is in the non-reversed position);

0 for the rudder blade plating beyond the wake of the propeller (when rudder is in the non-reversed position).

2.4.1.2 In any case, the thickness of the streamlined rudder blade side plating s_{\min} , in mm, shall be not less than determined by the formulae:

for ships of less than 80 m in length

$$s_{\min} = 21,5 \frac{L + 51}{L + 240}, \quad (2.4.1.2-1)$$

for ships of 80 m in length and over

$$s_{\min} = 24 \frac{L + 37}{L + 240}, \quad (2.4.1.2-2)$$

where: L – length of the ship, in m.

2.4.1.3 For ice class ships the thickness of the rudder blade side plating in way of the ice belt shall be not less than that of the ice belt of the shell plating in the after part of the ship, specified in 3.10.4.1, Part II "Hull", with the frame spacing being equal to the distance between the vertical web plates of the rudder blade.

The thickness s , in mm, of the rudder blade side plating for the icebreakers shall be not less than determined by the formula

$$s = 9,2k_{16}a\sqrt{\frac{p_a}{R_{eH}}} + 6, \quad (2.4.1.3-1)$$

where: a – distance between horizontal or vertical web plates, whichever is the less, for streamlined welded rudders; distance between rudder arms for single-plate steel solid-cast rudders, m.

In any case, in the calculations the value a shall not be taken less than 0,6 m;

p_a – intensity of ice pressure in the CI region determined according to 3.10.3.5.2, Part II "Hull", in kPa;

R_{eH} – upper yield stress of the material of the rudder blade plating, in MPa;

k_{16} – factor determined for streamlined welded rudders by the formula

$$k_{16} = 1 - 0,38(a/b)^2; \quad (2.4.1.3-2)$$

where: b – distance between horizontal or vertical web plates, whichever is the greater, in m.

For single-plate steel solid-cast rudders the value of k_{16} shall be taken in the calculations equal to 1.

2.4.1.4 The streamlined rudder blade side plating shall be stiffened from the inside by horizontal and vertical web plates. The thickness of the web plates shall be not less than that of the rudder blade side plating.

The side plating and web plates shall be welded together by fillet or plug welds with slots of linear form. Dimensions of elements of plug welds are selected according to 1.7.5.13, Part II "Hull".

The horizontal and vertical web plates shall be provided with sufficient number of openings for free drainage of water which may penetrate inside the rudder blade.

The rear edge of the rudder blade shall be rigidly fixed in the proper way.

2.4.1.5 The streamlined rudder blade shall be provided with top and bottom plates, the thickness of which shall be not less than 1,2 times the greater value of the side plating thickness according to **2.4.1.1**.

The top and bottom plates shall be fitted with drain plugs of corrosion-resistant metal.

2.4.1.6 The corners of the openings (in way of the pintles) in the side plating of the semispade rudder blade shall be rounded off. The radius of curvature shall be not less than 2 times the side plating thickness in this area, and the free edge of the rudder side plating shall be thoroughly stripped.

2.4.1.7 Near the rotation axis of the streamlined rudder one or several vertical web plates shall be provided ensuring the general strength of the rudder blade. The section modulus of these web plates, including the effective flanges, shall be such that the normal stresses in the considered section are not more than 0,5 times the upper yield stress of the material of the rudder blade side plating (refer to **1.5.2**).

The normal stresses σ , in MPa, shall be calculated by the formula

$$\sigma = 1000M_b/W, \quad (2.4.1.7)$$

where: M_b – bending moment in the considered section of the rudder blade (M_t or M_r) determined according to the provisions of **2.2.4** – **2.2.6** for the appropriate type of the rudder, in kN·m;

W – section modulus of the considered section of the web plates, including the effective flanges, about the axis of symmetry of the rudder blade profile, in cm³.

The dimensions of the effective flanges of the web plates shall be as follows:

the thickness equal to that of the rudder blade side plating;

the width equal to 1/6 of the rudder blade height or 1/2 of the distance between the nearest web plates located on both sides of the considered web plate, whichever is the less.

2.4.1.8 Special care shall be given to the reliable securing to the rudder blade of the flange for coupling the rudder blade and the rudder stock and of the gudgeons for pintles.

2.4.1.9 At the leading edge of the single-plate steel solid-case rudders of the icebreakers the rudder piece shall be provided over the entire height of the rudder blade. The equivalent stress σ_{eq} , in MPa, developed in any horizontal section of the rudder piece and determined by the formula given below shall not exceed 0,5 times the upper yield stress of the rudder blade material

$$\sigma_{eq} = 1000\sqrt{\left(\frac{M_r}{W}\right)^2 + 3\left(\frac{M_t y}{h_r \rho S}\right)^2}, \quad (2.4.1.9)$$

where: M_r – bending moment determined according to the provisions of **2.2.5.3**, in kN·m;

M_t – torque according to **2.2.2.3**, in kN·m;

h_r – height of the rudder measured on the rudder stock centre line, in m;

y – distance between the considered section and the lower edge of the rudder (refer to Fig. 2.4.1.9), in m;

W – section modulus of the considered cross-section of the rudder piece about the axis O_1-O_1 , ignoring the rudder blade plating (the rudder piece section taken into account in the calculation of W is hatched in section $I-I$ of Fig. 2.4.1.9), in cm³;

S – area of the considered cross-section of the rudder piece (refer to hatched area in section $I-I$ of Fig. 2.4.1.9), in cm²;

ρ – distance between the centroid of the area S and the rudder blade centre line, in cm.

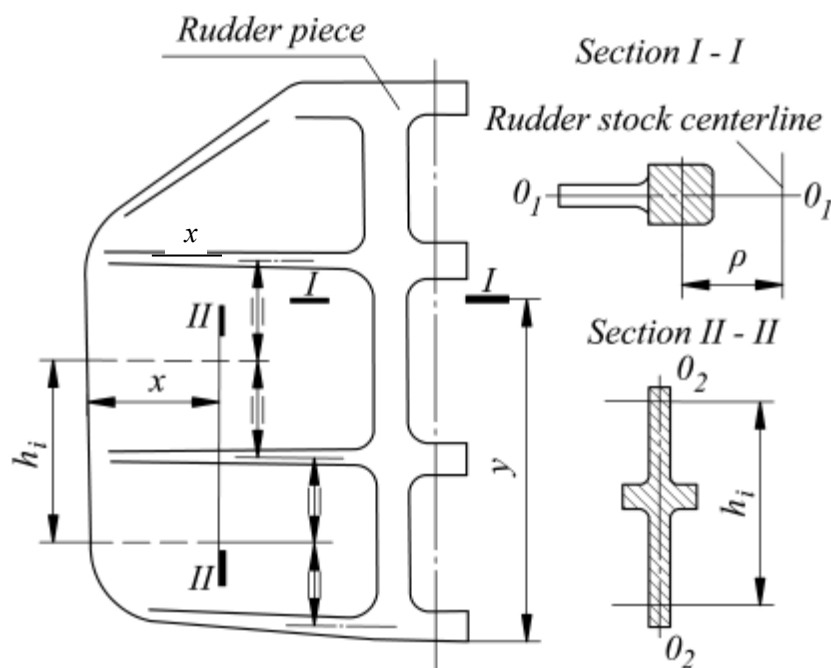

Fig. 2.4.1.9

2.4.1.10 The single-plate steel solid-case rudder shall be stiffened by the rudder arms founded on both sides of the rudder blade at the level of each gudgeon (refer to Fig. 2.4.1.9). The section modulus of the considered cross-section of the rudder arms W , in cm^3 , (including the body of the rudder blade within the dimension h_i , refer to section II - II in Fig. 2.4.1.9) about the axis $O_2 - O_2$ shall be not less than determined by the formula

$$W = \frac{1000h_i x^2 F}{AR_{eH}}, \quad (2.4.1.10)$$

where: F – force determined according to the provisions of 2.2.2.2, kN;

A – rudder area, in m^2 ;

h_i – linear dimension, in m (refer to Fig. 2.4.1.9);

x – distance between the considered section and the rear edge of the rudder, in m (refer to Fig. 2.4.1.9);

R_{eH} – upper yield stress of the rudder material, in MPa.

2.4.2 Steering nozzle rudder.

2.4.2.1 The thickness s_o , in mm, of the steering nozzle outside plating shall be not less than determined by the formula

$$s_o = k_{14} l_1 \sqrt{\frac{98D_n l_n d + 20F_n}{D_n l_n R_{eH}}} + 2, \quad (2.4.2.1-1)$$

where

D_n = inner minimum nozzle bore, in m;

l_n = length of the steering nozzle, in m;

d = draught of the ship, in m;

F_n = force acting on the steering nozzle according to 2.2.3.1, in kN;

R_{eH} = upper yield stress of the material of the steering nozzle outside plating, in MPa;

k_{14} = factor determined by the formula

$$k_{14} = 7,885 - 2,221(l_1/u_1)^2; \quad (2.4.2.1-2)$$

where:

l_1 – distance between transverse web plates or between the transverse web plate and the nearest edge of the steering

nozzle, in m. This distance shall not exceed 600 mm;

u_1 – distance between the longitudinal web plates measured along the length of the steering nozzle outside plating, in m. This distance shall not exceed 1000 mm.

2.4.2.2 The thickness s_{in} , in mm, of the steering nozzle inside plating, except for its middle belt, shall be not less than

$$s_{in} = 6,39 \frac{l_1}{D_n} \sqrt{T}, \quad (2.4.2.2-1)$$

where: T – propeller thrust at speed V , in kN.

The thickness s_m , in mm, of the middle belt of the steering nozzle inside plating shall be not less than

$$s_m = 7,34 \frac{l_2}{D_n} \sqrt{T} + 0,51 \frac{T}{D_n^2}, \quad (2.4.2.2-2)$$

where: l_2 – distance between transverse web plates situated in way of the middle belt of the inside plating, in m.

2.4.2.3 In any case, the thickness of the outside and inside plating of the steering nozzle shall be not less than that given in **2.4.1.2**.

2.4.2.4 The middle belt of the steering nozzle inside plating shall extend not less than $0,05D_n$ forward and not less than $0,1D_n$ aft of the propeller blade tips. Its breadth shall be at least equal to the maximum breadth of the side projection of the propeller blade.

2.4.2.5 The outside and inside plating of the steering nozzle shall be stiffened from the inside by transverse and longitudinal web plates. The spacing of the web plates shall comply with the requirements of **2.4.2.1**. At least four longitudinal web plates shall be provided which are equally spaced around the circumference of the steering nozzle.

The thickness of web plates, except those situated in way of the middle belt of the steering nozzle inside plating, shall be not less than the thickness of the outside plating according to **2.4.2.1** and **2.4.2.3**.

The transverse and longitudinal web plates shall be welded to the steering nozzle inside plating by double side continuous welds with full penetration on the inside of the steering nozzle. When the thickness of the web plates is 10 mm and more, edge preparation shall be carried out.

The outside plating and web plates shall be connected by plug welding with slots of linear form or by backing welding. The dimensions of elements of plug welds with slots of linear form are selected according to **1.7.5.13**, Part II "Hull".

The transverse and longitudinal web plates shall be provided with sufficient number of openings for free drainage of water which might penetrate inside the steering nozzle, and in the lower and upper parts of the outside plating the drain plugs of stainless metal shall be fitted. The distance from the opening edge to the inside and outside plating of the steering nozzle shall be not less than 0,25 times the web plate height.

It is not allowed to weld on doubling plates to the inside plating of the steering nozzle.

2.4.2.6 In way of the middle belt of the steering nozzle inside plating at least two continuous transverse web plates shall be fitted. The thickness of these web plates shall be not less than the thickness of the inside plating off its middle belt as per Formula (2.4.2.2-1).

2.4.2.7 Special care shall be given to the reliable securing of the nozzle flange, welded-in bush and other steering nozzle welded-in parts for connecting the steering nozzle welded-in parts for connecting the steering nozzle with its stock and pintle.

2.4.2.8 The thickness s_{st} of the stabilizer plating, in mm, shall be not less than determined by the formula

$$s_{st} = k_{14} l_1 \sqrt{\frac{98 A_{st} d + 20 F_{st}}{A_{st} R_{eH}}} + 2, \quad (2.4.2.8)$$

A_{st} = area of the steering nozzle stabilizer, in m²;

F_{st} = force acting on the stabilizer according to Formula (2.2.3.1-3), in kN;

k_{14} = factor according to **2.4.2.1** when the distance between horizontal web plates equals to u_1 , in m;

l_1 = distance between vertical web plates or between the web plate and fore or aft edge of the stabilizer, in m;

R_{eH} = upper yield stress of material of the stabilizer plating, in MPa.

2.4.2.9 The steering nozzle stabilizer plating shall be stiffened from the inside by horizontal and vertical web plates having the thickness not less than that of the plating in accordance with **2.4.2.8**.

The stabilizer body shall terminate in top and bottom plates. The thickness of top and bottom plates shall not be less than 1,5 times the thickness of the plating according to **2.4.2.8**. Vertical web plates shall be securely connected to top and bottom plates.

The plating and horizontal and vertical web plates shall be welded together by fillet or plug welds. The types of plug welds with slots of linear form are selected according to **1.7.5.13**, Part II "Hull".

The horizontal and vertical web plates shall be provided with sufficient number of openings, and top and bottom plates shall be fitted with drain plugs of corrosion-resistant material.

2.4.2.10 In way of attachment of the stabilizer to the steering nozzle one or several vertical web plates shall be provided ensuring general strength of the stabilizer. The section modulus W_{st} , in cm^3 , of these web plates, the effective flange included, shall be not less than determined by the formula

$$W_{st} = 1390 F_{st} h_{st} / R_{eH} , \quad (2.4.2.10)$$

where F_{st} =force acting on the stabilizer according to Formula (2.2.3.1-3), in kN;

h_{st} = stabilizer height, in m;

R_{eH} = upper yield stress of material of the stabilizer plating, in MPa.

The effective flange dimensions shall be as follows: thickness equal to the stabilizer plating thickness; width equal to 1/5 of the stabilizer height.

2.4.2.11 The steering nozzle and stabilizer shall be so connected that rigid fixation of the latter is ensured.

The force F_{st} determined from Formula (2.2.3.1-3) and uniformly distributed with the height of the stabilizer shall be taken in strength calculations as a force acting on the stabilizer. Depending on the type of connection a torque of force F_{st} acting on this connection shall be considered with regard to the point of application of this force (refer to Formula (2.2.3.2-3)).

In this case, stresses developed in the connection (refer to **1.5.1**) shall not exceed 0,4 times the upper yield stress of the material.

2.5 COUPLINGS

2.5.1 Horizontal flange coupling.

2.5.1.1 The diameter of the coupling bolts d_1 , cm, in cm, shall be not less than:

$$d_1 = 0,62 \sqrt{\frac{d_2^3 R_{eH1}}{z_1 r_2 R_{eH2}}} , \quad (2.5.1.1-1)$$

where d_2 =diameter of the rudder stock at the coupling flange, in cm;

z_1 =number of coupling bolts;

r_2 =mean distance from the centre of the bolts to the centre of the system of the flange bolt holes, in cm;

R_{eH1} =upper yield stress of the rudder stock material, in MPa;

R_{eH2} =upper yield stress of the bolt material, in MPa.

The coupling bolt diameter at the bottom of threads d_3 , in cm, shall be not less than determined by the formula

$$d_3 = 76,84 \sqrt{\frac{M_b}{z_1 r_3 R_{eH2}}} , \quad (2.5.1.1-2)$$

where M_b =bending moment acting in the rudder stock section at the flange (M_2 or M_3) determined according to the provisions of **2.2.4 - 2.2.7** for the appropriate type of the rudder, in $\text{kN}\cdot\text{m}$;

r_3 =mean distance from the centre of the bolts to the longitudinal axis of symmetry of the flange, in cm.

The number of bolts z_1 shall be not less than 6.

The mean distance from the centre of the bolts to the centre of the system of the flange bolt holes shall be

not less than 0,9 times the rudder stock diameter according to 2.3.1. When the coupling is under the action of the bending moment, the mean distance from the centre of the bolts to the longitudinal axis of symmetry of the flange shall be not less than 0,6 times the rudder stock diameter at the flange.

2.5.1.2 Only fitted bolts shall be employed, except the cases of a key setting when it is sufficient to have only two fitted bolts. The nuts shall have standard sizes. The bolts and nuts shall be efficiently secured.

2.5.1.3 The thickness of the coupling flanges shall not be less than the diameter of the bolts. The centres of the holes for bolts shall be distant from the outside edges of the flange by not less than 1,15 times the diameter of the bolts.

2.5.1.4 When coupling flanges of steering nozzles are not built into the steering nozzle body but connected to it by the structure formed of sheets, the strength of this structure shall be equivalent to that of the rudder stock in accordance with 2.3.2.

In this case, the calculated equivalent stress shall not exceed 0,4 times the upper yield stress of the material used.

2.5.2 Keyed cone coupling.

2.5.2.1 The cone length of the rudder stock fitted to the rudder blade or steering nozzle shall not be less than 1,5 times the diameter of the rudder stock according to 2.3.2; the cone on the diameter shall be 1:10. The cone shall change into cylindrical portion without any step in the diameter.

2.5.2.2 A key shall be set on the cone generatrix. The ends of the key shall be fairly rounded. The working sectional area of the key A_k (product of the key length by its width), in cm^2 , shall be not less than the greater value determined by the formula

$$A_k = \frac{k_{15} M_T}{d_m R_{eH}}, \quad (2.5.2.2)$$

where k_{15} =factor equal to:

6920 for rudders for the ahead condition and for steering nozzles;

4950 for rudders for the astern condition;

M_T =torque according to 2.2.2.3, 2.2.2.4 or 2.2.3.3, in $\text{kN}\cdot\text{m}$;

d_m =diameter of the cone section at the middle of the key length, in cm ;

R_{eH} =upper yield stress of the key material, in MPa .

The height of the key shall be not less than half its width.

The keyway of the rudder stock shall be confined to the cone coupling.

2.5.2.3 The external diameter of the rudder stock threaded portion shall not be less than 0,9 times the minimum diameter of the cone. The thread shall be fine. The outer diameter and height of the nut shall not be less than 1,5 and 0,8 times the external diameter of the rudder stock threaded portion, respectively. To prevent self-unscrewing, the nut shall be securely fastened at least by two welded-on strips or one welded-on strip and a split pin.

2.5.3 Keyless cone coupling.

2.5.3.1 The requirements of 2.5.3 are applicable to a keyless fitting of the rudder stock to the rudder blade or steering nozzle which is made by oil injection method.

2.5.3.2 The cone length of the rudder stock fitted to the rudder blade or steering nozzle shall not be less than 1,5 times the diameter of the rudder stock according to 2.3.2; the cone on the diameter shall be 1:15.

2.5.3.3 The rudder blade or steering nozzle boss shall be a good fit on the rudder stock cone. During the fit up, and before the push-up load is applied, an area of contact of at least 70 % of the theoretical area of contact shall be achieved, and this shall be distributed evenly.

The relationship of the rudder stock and boss cones at which this occurs shall be marked, and push-up length then measured from that point.

In well-founded cases another method of determining the original position of the rudder stock and boss cones relationship can be used.

2.5.3.4 To ensure the required interference in the cone coupling the push-up length of the rudder stock (refer to 2.5.3.3) during its fitting shall be not less than determined by the formula

$$s_1 = \frac{1,1q}{EK} \left[\frac{2d_m}{1 - \left(\frac{d_m}{d_c}\right)^2} + 35,7 \right], \quad (2.5.3.4-1)$$

where s_1 =push-up length of the rudder stock, in mm;

d_m =mean diameter of the rudder stock cone, in mm;

d_c =outer diameter (or minimum outer dimension) of rudder blade boss or steering nozzle (in the mean section), in mm;

E =modulus of elasticity of rudder stock material, in MPa;

K = taper of conical coupling, on the diameter;

q =required contact pressure applied to mating surfaces during the push-up, in MPa, determined by the formula

$$q = \frac{4,25 \cdot 10^6 n M_t}{d_m^2 L_a} \sqrt{1 + \left(\frac{5 \cdot 10^{-6} Q d_m}{M_t}\right)^2} \times \left(1 + 0,257 \frac{L_a M_b}{d_m M_t}\right) \quad (2.5.3.4-2)$$

where n = safety factor against friction slip under the action of rated torque;

M_t = maximum value of design torque according to 2.2.2.3, 2.2.2.4 or 2.2.3.3, in kN·m;

L_a = actual length of the contact part of cone, excluding the oil distribution grooves and similar devices, in mm;

Q = mass of rudder blade or steering nozzle, in kg;

M_b = maximum bending moment in way of cone coupling determined according to 2.2.4.8, 2.2.6.3 or 2.2.7.3, in kN·m.

The spade rudders and steering nozzles of types XIV and XV (refer to Fig. 2.2.4.1) the value n shall be taken not less than 2,5; for other types of rudders and steering nozzles this value shall be not less than 2,0.

If the contact pressure q determined by Formula (2.5.3.4-2) is less than 40 MPa, then $q=40$ MPa shall be taken in the calculations.

2.5.3.5 The strength of the maximum loaded part of the coupling shall be checked: the combined stress on the inside of the rudder blade or steering nozzle boss shall not exceed 0,85 of the yield stress of the boss material. The combined stress σ_{com} , on the inside of the boss shall be determined by the formula

$$\sigma_{com} = \sqrt{0,5(\sigma_1 - \sigma_2)^2 + 0,5(\sigma_2 - \sigma_3)^2 + 0,5(\sigma_3 - \sigma_1)^2}, \quad (2.5.3.5-1)$$

where:

$$\sigma_1 = q_1 \frac{d_c^2 + d_3^2}{d_c^2 - d_3^2}; \quad (2.5.3.5-2)$$

$$q_1 = q + 5,73 \frac{M_b \cdot 10^6}{d_3 L_{s,t}^2}; \quad (2.5.3.5-3)$$

$$\sigma_2 = -q_1; \quad (2.5.3.5-4)$$

$$\sigma_3 = \frac{40Q}{\pi(d_c^2 - d_3^2)} + \frac{M_b \cdot 10^7}{d_3^3}; \quad (2.5.3.5-5)$$

q_1 = contact pressure between mating cone surfaces in way of maximum diameter of the rudder stock cone under combined action of torque and bending moments, in MPa;

d_3 =maximum diameter of rudder stock cone, in mm;

$L_{s,t}$ = length of rudder stock cone, in mm.

2.5.3.6 The value of oil pressure applied to the mating cone surfaces of the rudder stock and rudder blade boss during mounting and dismounting of the coupling shall not exceed p_{max} , in MPa, determined by the formula

$$P_{\max} = 0,55R_{eH} \left[1 - \left(\frac{d_m}{d_c} \right)^2 \right], \quad (2.5.3.6)$$

where R_{eH} = yield stress of material of the rudder blade or steering nozzle boss, in MPa.

2.5.4 Where the rudder stock is not made of a solid piece, its parts shall be joined by means of a muff coupling or by other method which shall ensure a strength equivalent to that of the rudder stock.

2.6 RUDDER PINTLES

2.6.1 The diameter d_4 , in cm, of pintles without liners, as well as of pintles with liners, but before their setting, shall be not less than determined by the formula

$$d_4 = 18\sqrt{R_i/R_{eH}}, \quad (2.6.1)$$

where R_i = design value of the reaction of the considered pindle (R_2 or R_d) determined according to the provisions of **2.2.4** and **2.2.5** for the appropriate type of the rudder, in kN;

R_{eH} = upper yield stress of the pindle material, in MPa.

2.6.2 The length of the cone part of the pindle in rudder gudgeon, in welded-in bush of the steering nozzle or in the solepiece shall not be less than the diameter of the pindle according to **2.6.1**; the cone on the diameter shall not exceed 1:10. The cone shall change into cylindrical portion without any step in the diameter.

The external diameter of the pindle threaded portion shall not be less than 0,8 times the minimum diameter of the cone. The outer diameter and height of the nut shall not be less than 1,5 and 0,6 times the external diameter of the pindle threaded portion, respectively.

2.6.3 The ratio of bearing height to diameter measured outside the pindle liners, where fitted, shall not be less than 1, nor more than 1,3.

2.6.4 The width of material in the rudder gudgeons and welded-in bushes of the steering nozzle measured outside the hole for the pindle bush shall not be less than 0,5 times the diameter of the pindle without liner. For rudder pintles of 200 mm and over in diameter it is allowed to reduce the specified width of the gudgeon from 0,5 times the diameter of the gudgeon down to 0,35 times the diameter of the pindle without liner in case the requirements of 2.6.2 and 2.6.3 are met, the following relation is obtained:

$$\frac{l_7}{d_4} \geq \frac{R_{eH(p)}}{R_{eH(g)}}, \quad (2.6.4)$$

where l_7 = height of the pindle bush, in cm;

d_4 = diameter of the pindle, in cm, including its liner, where fitted;

$R_{eH(p)}$ = upper yield stress of the pindle material, in MPa;

$R_{eH(g)}$ = upper yield stress of the gudgeon material, in MPa.

2.6.5 To prevent self-unscrewing, the nut shall be securely fastened by means of at least two welded-on strips or one welded-on strip and a split pin, and the pintles shall be securely fastened in gudgeons of the rudder or sternframe.

2.6.6 The chosen dimensions of the pintles shall be checked by the surface loading p , in MPa, this being taken as

$$p = 10R_i / (d'_4 l_7), \quad (2.6.6)$$

where for R_i – refer to **2.6.1**;

d'_4 = diameter of the pindle, in cm, including its liner, where fitted;

l_7 = height of the pindle bush, in cm.

This surface loading shall not exceed the values specified in Table 2.1.7.

2.7 RUDDER AXLE

2.7.1 The diameter of the rudder axle directly at the flanges shall be such that the normal stresses σ developed in its sections do not exceed 0,5 times the upper yield stress of the rudder axle material. The normal stress σ , in MPa, shall be determined by the formula

$$\sigma = 10^4 M_{r-a} / d_5^3, \quad (2.7.1)$$

where

M_{r-a} = design value of the bending moment determined according to the provisions of **2.2.4.15**, in kN·m;

d_5 = diameter of the rudder axle at the flange, in cm.

The diameter of the rudder axle in way of the rudder bearings shall be not less than the diameter d_5 . The diameter of the rudder axle between the rudder blade bearings may be reduced by 10%.

2.7.2 As regards the cone and threaded portions of the rudder axle and also its nut, the requirements are as stipulated in **2.6.2** for the pintles.

2.7.3 The diameter of bolts of the rudder axle flange coupling d_6 , in cm, shall be not less than determined by the formula

$$d_6 = 6,77 \sqrt{\frac{R_2 + \frac{M_{r-a}}{r_4} \sqrt{1 + \left(0,17 + 0,6 \frac{R_2 r_5}{M_{r-a}}\right)^2}}{z_2 R_{eH}}} \quad (2.7.3)$$

where R_2 = design value of the reaction of the rudder axle upper bearing determined according to **2.2.4.11**, in kN;

M_{r-a} = design value of the bending moment acting in the rudder axle section near its flange determined according to **2.2.4.15**, in kN·m;

r_4 = mean distance from the centre of the bolts to the centre of the system of the flange bolt holes, in m;

r_5 = distance from the centre line of the rudder stock to the contact plane of the rudder axle flanges and the sternframe, in m;

z_2 = number of the bolts of the flange coupling;

R_{eH} = upper yield stress of the bolt material, in MPa.

The number of the bolts z_2 shall be not less than 6.

The distance from the centre of any bolt to the centre of the system of the flange bolt holes shall be not less than 0,7, and to the vertical axis of symmetry of the flange plane, not less than 0,6 times the diameter d_5 , of the rudder axle given in **2.7.1**.

2.7.4 Only fitted bolts shall be employed, except the cases of a key setting when it is sufficient to have only two fitted bolts. The nuts shall have standard sizes, and they shall be securely fastened by split pins or weld-on strips.

2.7.5 The thickness of the coupling flange shall not be less than the diameter of the bolts. The centres of the holes for bolts shall be distant from the outside edges of the flange by not less than 1,15 times the diameter of the bolts.

2.7.6 Where the diameter of the rudder axle changes, sufficient fillets shall be provided. At transition from the rudder axle to the flange a fillet shall be provided with a radius of not less than 0,12 times the rudder axle diameter.

2.7.7 To prevent self-unscrewing, the nut of the rudder axle shall be securely fastened at least by two weld-on strips or one weld-on strip and a split pin.

2.7.8 The requirements of **2.6.6** for pintles are applicable to the rudder blade bearings on the rudder axle.

2.8 RUDDER STOCK BEARINGS

2.8.1 The requirements of **2.6.6** for pintles are applicable to the rudder stock bearings taking lateral load.

2.8.2 A rudder carrier shall be installed to take the mass of the rudder blade or steering nozzle and rudder stock. The deck shall be efficiently strengthened in way of the rudder carrier. Measures shall be taken against axial displacement of the rudder blade or steering nozzle and rudder stock upwards by a value exceeding that permitted by the construction of the steering gear; furthermore, for steering nozzle measures shall be taken to provide for guaranteed clearance between propeller blades and nozzle under service conditions.

2.8.3 A stuffing box shall be fitted in way of passage of the rudder stock through the top of a rudder trunk which is open to sea to prevent water from entering the ship's space. The stuffing box shall be fitted in a place accessible for inspection and maintenance at all times.

2.9 STEERING GEAR

2.9.1 Ships shall be provided with a main steering gear and an auxiliary steering gear, unless expressly provided otherwise.

2.9.2 The main steering gear and rudder stock shall be capable of putting the rudder or steering nozzle over from 35° on one side to 35° on the other side with the ship at its deepest seagoing draught and running ahead at maximum ahead service speed and under the same conditions, from 35° on either side to 30° on the other side in not more than 28 s.

2.9.3 The auxiliary steering shall be capable of putting the rudder or steering nozzle over from 15° on one side to 15° on the other side in not more than 60 s with the ship at its deepest sea going draught and running ahead at one half of the maximum ahead service speed or 7 knots, whichever is the greater.

2.9.4 In oil tankers, oil tankers (>60° C), combination carriers, gas carriers and chemical tankers of 10000 gross tonnage and upwards, in all nuclear ships and in other ships of 70 000 gross tonnage and upwards the main steering gear shall comprise two or more identical power units satisfying the requirements of **2.9.5** (refer also to **6.2.1.8** and **6.2.1.9**, Part IX "Machinery").

2.9.5 Where the main steering gear comprises two or more power units, an auxiliary steering gear need not be fitted if:

.1 in passenger and nuclear ships as well as in special purpose ships having more than 240 persons on board the main steering gear is capable of operating as required in **2.9.2** while any one of the power units is out of operation;

.2 in cargo ships as well as in special purpose ships having 240 or less persons on board the main steering gear is capable of operating as required in **2.9.2** while all power units are in operation;

.3 the main steering gear is so arranged that after a single failure in its piping system or in any one of the power units the defect can be isolated so that steering capability can be maintained or speedily regained.

2.9.6 Where according to 2.3.1 the diameter of the rudder head is required to be over 230 mm, excluding strengthening for navigation in ice, provision shall be made for an additional source of electrical power as prescribed in **5.5.6**, Part XI "Electrical Equipment" sufficient to ensure operation of the steering gear power unit in compliance with the requirements of **2.9.3**.

2.9.7 The main steering gear may be hand-operated provided it meets the requirements of **6.2.3.2**, Part IX "Machinery" and the rudder stock and steering nozzle diameter specified in **2.3.1** does not exceed 120 mm (excluding strengthening for navigation in ice). In all other cases, the main steering gear shall be operated by power.

2.9.8 The auxiliary steering gear may be handoperated provided it meets the requirements of **6.2.3.3**, Part IX "Machinery" and the rudder stock or steering nozzle diameter specified in **2.3.1** does not exceed 230 mm (excluding strengthening for navigation in ice). In all other cases, the auxiliary steering gear shall be operated by power.

2.9.9 The main and auxiliary steering gears shall act on the rudder stock independently of one another, but it is allowed that the main and auxiliary steering gears have some common parts (such as tiller, quadrant, gear box, cylinder block, etc.) provided the respective scantlings of these parts are increased in accordance with **6.2.8.2**, Part IX "Machinery".

2.9.10 The rudder tackle may be considered as an auxiliary steering gear only in the following cases:

.1 in self-propelled ships of less than 500 gross tonnage;

.2 in non-propelled ships. In other cases, the rudder tackle is not considered as a steering gear and shall not necessarily be fitted in ships.

2.9.11 The rudder shall be provided with a system of stops permitting to put the rudder over either side only to an angle β° :

$$(\alpha^\circ + 1^\circ) \leq \beta^\circ \leq (\alpha^\circ + 1,5^\circ), \quad (2.9.11-1)$$

where: α° – maximum hard-over angle to which the steering gear control system is adjusted but not over 358; technical background for the greater hard-over angle, based on the constructional features of the steering gear, shall be submitted by the designer.

All the parts of the system of stops, including those which are at the same time the parts of the steering gear, shall be calculated to take forces corresponding to an ultimate reverse torque M_{ult} , in kN·m, from the rudder of not less than:

$$M_{ult} = 1,135 R_{eH} d^3 \cdot 10^{-4} \quad (2.9.11-2)$$

where: d – actual diameter of the rudder stock head, in cm;
 R_{eH} – upper yield stress of the rudder stock material, in MPa.

The stresses in these parts shall not exceed 0,95 times the upper yield stress of their material.

The rudder stops of the system may be fitted on the sternframe, deck platform, bulkhead or other structural members of the ship's hull.

Where an active rudder is installed and putting the rudder over to an angle exceeding the maximum one is required, arrangement of stops at an angle provided by the rudder design may be allowed.

2.9.12 Control of the main steering gear shall be provided both on the navigation bridge and in the steering gear compartment.

2.9.13 When the main steering gear is arranged according to **2.9.4** or **2.9.5**, two independent steering gear control systems shall be provided, each of which shall be operable separately from the navigation bridge. These systems may have a common steering wheel or level. If the control system comprises a hydraulic telemotor, the Register may waive the requirement for a second independent control system of the steering gear for the ship (with the exception of oil tankers, oil tankers (>60°C), combination carriers, gas carriers and chemical tankers of 10 000 gross tonnage and upwards, of other ships of 70 000 gross tonnage and upwards and of nuclear ships).

2.9.14 The auxiliary steering gear control shall be provided in the steering gear compartment.

For the auxiliary steering gear which is power operated, control shall also be provided from the navigation bridge and shall be independent of the control system for the main steering gear.

For ships of less than 500 gross tonnage and fishing vessels, the auxiliary steering gear control may not be provided from the steering gear compartment.

2.9.15 A rudder or steering nozzle angle indicator shall be fitted in the vicinity of each control station of the main and auxiliary steering gears and in the steering gear compartment.

The difference between the indicated and actual positions of the rudder or steering nozzle shall be not more than:

1° when the rudder or steering nozzle is in the centre line or parallel to it;

1,5° for rudder or steering nozzle angles from 0° - 5°;

2,5° for rudder or steering nozzle angles from 5° - 35°.

The rudder or steering nozzle angle indication shall be independent of the steering gear control system.

2.9.16 In all other respects the steering gear shall meet the requirements of Part IX "Machinery" and Part XI "Electrical Equipment".

2.9.17 Where compliance with the requirements of **2.9.2** and **2.9.3**, when conducting sea trials, is impossible, the ship, regardless of the date of construction, can confirm compliance with the requirements of **2.9.2** and **2.9.3** by other methods (refer to Resolution MSC.365 (93) of 22.05 .2014).

2.9.18 If the steering gear is mechanically driven, then in case of damage or malfunction of the control device, the second control device or manual drive shall be automatically actuated within 5 s.

If the other control unit or manual drive is not automatically actuated, it shall be possible for the helmsman to actuate it in a quick and easy way in one operation.

2.10 EFFICIENCY OF RUDDERS AND STEERING NOZZLES

2.10.1 General.

2.10.1.1 The choice of the ship's main characteristics affecting the steerability and the characteristics of the rudder and steering nozzle is made at the discretion of the designer and shipowner considering the necessity to ensure the proper steerability of the ship according to its purpose and service conditions and to ensure the correspondence between relative areas of rudders and steering nozzles of the ship under design and the prototype ship provided the total efficiency of the chosen rudders and/or steering nozzles is not less than that required in this Chapter.

2.10.1.2 The requirements of this Chapter apply to stern rudders and steering nozzles (refer to **2.1.2**) provided according to **2.1.1** in self-propelled ships (other than icebreakers) of 20 m and over in length of unrestricted service **A** and restricted areas of navigation **R1** and **A-R1** sailing in the displacement condition.

For ships of restricted areas of navigation **R2**, **A-R2**, **R2-S**, **A-R2-S**, **B-R3-S**, **C-R3-S**, **R3-S** and **R3** the standards set forth in **2.10.3** shall be considered as recommendations.

For ships of river-sea navigation **R2-RS**, **A-R2-RS**, **B-R3-RS**, **C-R3-RS**, **R3-RS**, **D-R3-RS**, **R3-IN** the standards set forth in **2.10.3** shall also be considered as recommendations, and the fulfilment of these standards does not give the grounds for exemption from the fulfilment of the current standards of steerability for ships of inland navigation, complying with Chapter 20 of UN ECE Resolution No. 61 with amendments.

2.10.1.3 The requirements of this Chapter apply to ships having the geometric characteristics of the hull within the following limits:

$$L_1/B = 3,2 \dots 8,0 ;$$

$$L_1/d = 8,3 \dots 28,6 ;$$

$$B/d = 1,5 \dots 3,5 ;$$

$$C_B = 0,45 \dots 0,85 ;$$

$$C_p = 0,55 \dots 0,85 ;$$

$$\sigma_a = 0,80 \dots 0,99 ,$$

where B = breadth of the ship, in m;

for C_B , d , L_1 , C_p and s_a , refer to **2.2.2.1**, **2.4.1.1** and **2.10.3.3**, respectively.

2.10.1.4 The requirements of this Chapter apply to catamarans with two identical hulls (symmetric about the centerline of the hulls), each having geometric characteristics according to the provisions of **2.10.1.3**, and with two identical rudders and/or steering nozzles arranged in the centre plane of each hull.

2.10.1.5 The active means of the ship's steering which are not the main means of the ship's steering (thrusters, active rudders, etc.) are considered as means supplementing the required minimum and are not taken into account when meeting the requirements of this Chapter (refer also to **2.1.4.2**).

2.10.2 Estimation of efficiency of rudders and steering nozzles.

2.10.2.1 The efficiency of the chosen rudder E_r , other than rudders of types IV, X and XIII (refer to Fig. 2.2.4.1), shall be determined by the formula

$$E_r = \mu_1 \frac{A}{A_2} \left(1 + C_{HB} \frac{A_p}{A} \right) (1 - W)^2, \quad (2.10.2.1-1)$$

$$\text{where: } \mu_1 = \frac{6,28}{1 + \frac{2A}{h_r^2}}; \quad (2.10.2.1-2)$$

W – coefficient: for rudder arranged in the centreline behind the propeller,

$$W = 0,3C_B; \quad (2.10.2.1-3)$$

for rudder arranged in the centreline with no propeller fitted forward of it

$$W = 0; \quad (2.10.2.1-4)$$

for side rudders

$$W = 0,4C_B - 0,13; \quad (2.10.2.1-5)$$

A_2 – lateral underwater area at the summer load waterline draught, in m²;

for A , A_p , h_r , C_B – refer to **2.2.2.1**;

C_{HB} – value determined by Formula (2.2.3.1-8) with regard to Formula (2.2.3.1-4) at W as specified in this para with regard to **2.2.2.6**; for rudders not operating directly behind the propeller the thrust is taken as $T = 0$.

2.10.2.2 The efficiency of the chosen rudder E_{rr} of types IV, X or XIII (refer to Fig. 2.2.4.1) shall be determined by the formula

$$E_{rr} = 1,3\mu_2 \frac{A_l}{A_2} (1 - W)^2, \quad (2.10.2.2-1)$$

$$\mu_2 = \frac{6,28\sqrt{b_r b_t}}{1 + \frac{2b_r^2}{A_t}} + \frac{1,4C_{HB}}{1 + 0,5\left(\frac{b_r^2}{A_t}\right)^2}$$

where: (2.10.2.2-2)

where: b_r = breadth of the rudder, in m;
 b_t = total breadth of the rudder and rudder post, in m;
 for A_t , refer to 2.2.2.1;
 for A_2 , C_{HB} , W , refer to 2.10.2.1.

2.10.2.3 The efficiency of the chosen steering nozzle E_n with or without a stabilizer shall be determined by the formula

$$E_n = 2,86\mu_3 \frac{D_0 l_n}{A_2} (1 - W)^2$$

(2.10.2.3-1)

where:

$$\mu_3 = (0,175 + 0,275\frac{D_n}{l_n}) [1 + 0,25(1 + \sqrt{1 + C_{HB}^2})] + 0,25C_{HB} \frac{D_n}{l_n}$$

(2.10.2.3-2)

W – coefficient:

for steering nozzle arranged in the centreline of the ship

$$W = 0,2C_B;$$

(2.10.2.3-3)

for side steering nozzle

$$W = 0,1C_B;$$

(2.10.2.3-4)

D_0 – outside diameter of the steering nozzle in the plane of the propeller disk, in m;

for C_B , D_n , l_n and A_2 , refer to 2.2.2.1, 2.2.3.1 and 2.10.2.1, respectively;

C_{HB} = value determined by Formula (2.2.3.1-8) with regard to Formula (2.2.3.1-4) at W as specified in this para with regard to 2.2.2.6.

2.10.3 Standards for efficiency of rudders and steering nozzles.

2.10.3.1 The total efficiency of all rudders and steering nozzles (refer to 2.10.2) fitted in the ship (other than catamaran) shall not be less than the greater of the values E_1 , E_2 or E_3 , given below.

2.10.3.2 The efficiency of the single rudder or steering nozzle fitted in the catamaran which is determined according to 2.10.2 shall not be less than the greater of the values E_1 , E_2 and E_3 , estimated according to the provisions specified below considering each hull of the catamaran as an independent single-screw ship.

When determining the side-projected area (windage area), all the above-water structures of the catamaran and the deck cargo (if intended to be carried) are considered as belonging to one hull.

2.10.3.3 For all ships, other than tugs, rescue and fishing vessels, the value of E_1 is determined depending on the values of C_p and σ_a :

for single-screw ships - according to Fig. 2.10.3.3-1;

for twin-screw and triple-screw ships - according to Fig. 2.10.3.3-2.

For intermediate values of C_p the value of E_1 is determined by linear interpolation between the curves for two nearest values of C_p , given in Figs. 2.10.3.3-1 and 2.10.3.3-2 where C_p – is prismatic coefficient of the underwater part of the hull at the summer load waterline draught as determined by the formula:

$$C_p = C_B / C_m,$$

(2.10.3.3-1)

where: C_m – coefficient of fineness of midship section at the summer load waterline draught;

σ_a – afterbody lateral area coefficient at the summer load waterline draught as determined by the formula:

$$\sigma_a = 1 - \frac{2(f - f_0)}{L_1 d}$$

(2.10.3.3-2)

L_1 – length of the ship measured on the summer load waterline from the fore side of the stem to the after side of the after end of the ship, in m;

f – area of side projection of the stern counter, in m², calculated as the area of the figure bounded by the extension

line of the keel lower edge, by the perpendicular to this line from the point of intersection of the summer load waterline and the outline of the centreline section of the ship's after end and by the sternframe after edge line drawn ignoring the rudder post, solepiece or rudder horn, if any;

f_0 – for twin-screw ships - area of the side projection of the propeller cone (or its part) superimposed on the area of the figure f , in m^2 . In all other cases f_0 shall be taken as zero;

for d – refer to 2.4.1.1.

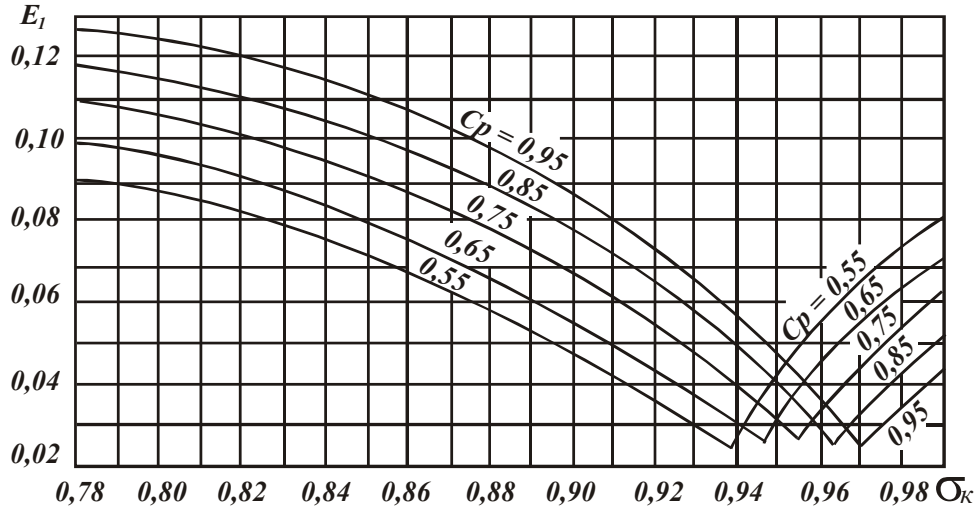

Fig. 2.10.3.3-1

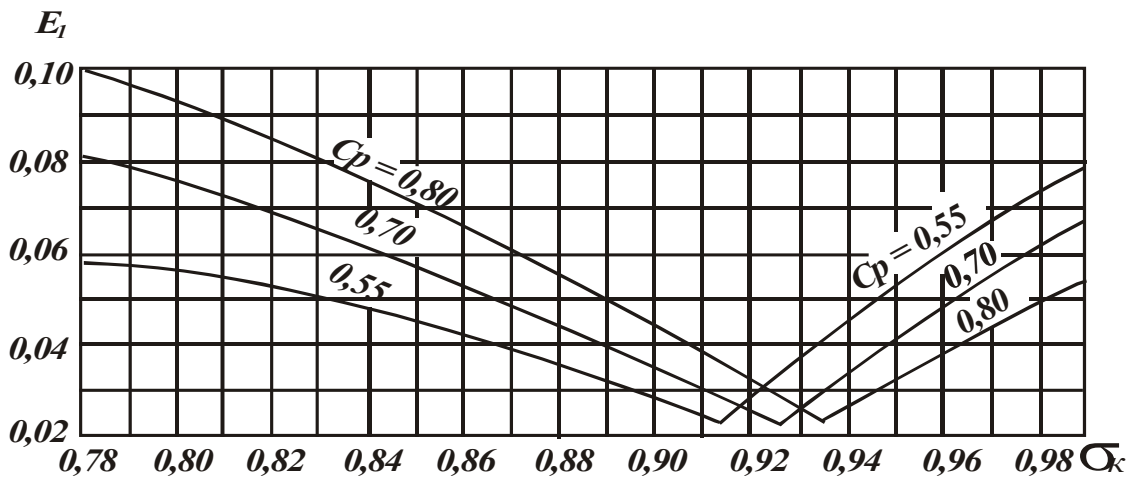

Fig. 2.10.3.3-2

2.10.3.4 For tugs, rescue ships and fishing vessels the value E_1 is determined according to Fig. 2.10.3.4 depending on the value σ_a

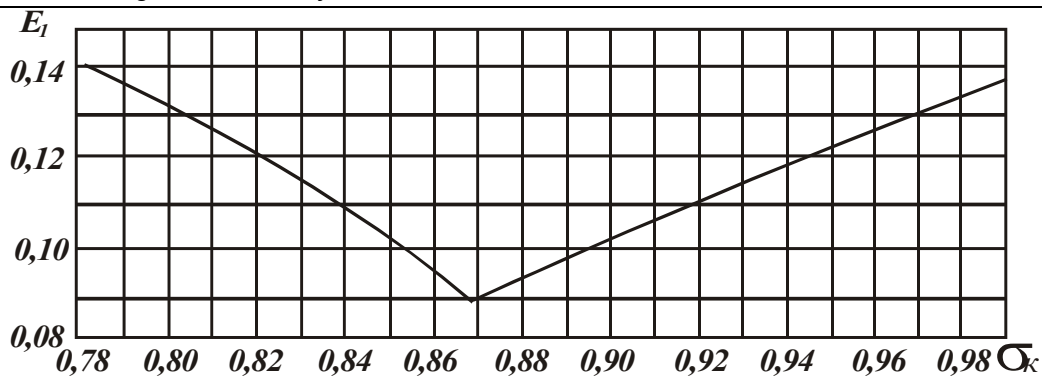

Fig. 2.10.3.4

2.10.3.5 The value E_2 is determined by the formula:

$$E_2 = \frac{3,8A_3}{v^2A_4} \left(1 - 0,0667 \frac{A_3}{A_4}\right) \left\{1 + (\lambda_r - 1)[0,33 + 0,015 \times (v - 7,5)] - 5 \frac{x_0}{L_1}\right\}, \quad (2.10.3.5-1)$$

where: A_3 – side-projected area at such a minimum draught at which the rudder blade or steering nozzle is fully immersed (at the upright position of the ship), in m^2 , to be determined according to 1.4.6, Part IV "Stability";

A_4 – lateral underwater area at such a minimum draught at which the rudder blade or steering nozzle is fully immersed (at the upright position of the ship), in m^2 ;

x_0 – horizontal distance from the midship frame (middle of the length L_1) to the centroid of the area A_3 , in m.

The value of x_0 is taken to be positive in case the centroid is forward of the midship frame, and negative in case of aft position;

λ_r – coefficient determined by the formulae:

for all rudders, other than rudders of types IV, X and XIII (refer to Fig.2.2.4.1)

$$\lambda_r = h_r^2 / A; \quad (2.10.3.5-2)$$

for rudders of types IV, X, XIII (refer to Fig.2.2.4.1)

$$\lambda_r = h_r^2 / A_i; \quad (2.10.3.5-3)$$

for steering nozzles

$$\lambda_r = D_n / l_n; \quad (2.10.3.5-4)$$

where for v , h_r , A , A_i , refer to 2.2.2.1;

for D_n , l_n , refer to 2.2.3.1.

2.10.3.6 For ships of 70 m in length and more the value E_3 is determined by the formula

$$E_3 = 0,03 + 0,01(\lambda_r - 1) + 0,01 \frac{A_5}{A_2} \left(1 - 3 \frac{x}{L_1}\right) \quad (2.10.3.6)$$

where: A_5 – side-projected area of the ship at the summer load waterline draught, in m^2 , to be determined according to 1.4.6, Part IV "Stability";

x – horizontal distance from the midship frame (middle of the length L_1) to the centroid of the area A_5 , in m;

for A_2 – refer to 2.10.2.1;

for λ_r – refer to 2.10.3.5.

The value of x is taken to be positive in case the centroid is forward of the midship frame and negative in case of aft position.

For ships of less than 70 m in length $E_3=0$ is taken in the calculations.

2.10.3.7 For all ships (other than rescue and fishing vessels and tugs, with $\sigma_a > 0,865$), it is permitted in the calculations to take E_1 as zero (if the value of E_1 is greater than any of the values of E_2 or E_3) provided it is proved by the test of a self-propelled model not less than 2 m in length (at the speed of the model conforming to the ship's speed V , refer to 2.2.2.1) that:

.1 the steady turning diameter of the ship with the rudder (rudders) or steering nozzle (rudders) put over to 35° on either side is not more than four lengths of the ship;

.2 the steady spontaneous turning diameter of the ship with non-reversed rudder (rudders) or steering nozzle (rudders) D_s determined by the formula

$$D_s = (D_{ss} + D_{sp})/2 \quad (2.10.3.7)$$

is not less than $3,35 (D_{ts} + D_{tp})$

where: D_{ts} and D_{tp} = steady turning diameter of the ship with the rudder or steering nozzle put over to 35° on starboard or port side, respectively;

D_{ss} and D_{sp} = diameter of steady spontaneous turning starboard or port, respectively, with the non-reversed rudder or steering nozzle.

2.10.3.8 For ships with the displacement exceeding 60000 t and block coefficient exceeding 0,75 at the summer load waterline draught, the compliance with the requirements of **2.10.3.7.1** and **2.10.3.7.2** shall be proved by testing a self-propelled model of not less than 2 m in length (at the speed of the model conforming to the ship's speed V , refer to **2.2.2.1**), notwithstanding the fulfilment of the requirements of **2.10.3.1**.

2.11 ADDITIONAL REQUIREMENTS FOR BALTIC ICE CLASS SHIPS

The scantlings of rudder post, rudder stock, pintles, steering engine etc. as well as the capability of the steering engine shall be determined according to the requirements of this Chapter. The steering gear of Baltic ice class **IA** and **IA Super** ships shall comply with the requirements to **Ice4** and **Ice5** ships respectively.

The maximum service speed of the ship to be used in these calculations shall, however, not be taken as less than stated below:

IA Super – 20 knots;

IA – 18 knots;

IB – 16 knots;

IC – 14 knots.

If the actual maximum service speed of the ship is higher, that speed shall be used.

The scantlings of structural elements of the rudder blade shall be determined on the basis that the steering gear is completely located in the ice zone of the ship. The scantlings of rudder blade plate elements and stiffeners shall be determined at an ice load intensity p , which corresponds to the intensity of the ice load on the plate and beam elements in the midship.

For the ice classes **IA Super** and **IA** the rudder stock and the upper edge of the rudder shall be protected against ice pressure by an ice knife or equivalent means, located aft of the rudder, which in its dimensions shall extend beyond the lower ice waterline (LIWL see 3.12, Part "Hull"), to the extent possible for this design, or with the help of other measures equivalent in degree of protection.

When using a rudder with a flap, the design of an ice knife shall provide the necessary strength of the rudder blade.

For the ice classes **IA Super** and **IA** due regard shall be paid to the excessive load caused by the rudder being forced out of the midship position when backing into an ice ridge. Where possible, rudder stoppers working on the blade or rudder head shall be fitted.

Relief valves for hydraulic pressure shall be effective.

The components of the steering gear shall be dimensioned to stand the yield torque of the rudder stock, at which a stress arises for the calculated diameter of the rudder equal to the minimum value of the conditional yield strength of the material.

3. ANCHOR ARRANGEMENT

3.1 GENERAL

3.1.1 Each ship shall be provided with anchoring equipment and also with chain stoppers for securing the

bower anchors in hawse pipes, devices for securing and releasing the inboard ends of the chain cables and machinery for dropping and hoisting the bower anchors as well as for holding the ship at the bower anchors dropped.

Besides, in cases specified in **3.6.1.1** each bower anchor chain cable shall be provided with a stopper for riding the ship at anchor.

The requirements of this Section for selection of anchoring equipment do not apply to oil tankers of 150 m in length and above as well as bulk carriers of 90 m in length and above, contracted for construction on or after 1 July 2015. The requirements for anchoring equipment of the said ships are regulated by IACS Common Rules for Bulk Carriers and Oil Tankers

3.1.2 If a ship in addition to the anchor arrangement or anchoring equipment specified in 3.1.1 is provided with some other anchor arrangement or anchoring equipment (for example, special anchors and winches on dredgers, mooring anchors on lightships, etc.), such anchor arrangement or anchoring equipment is regarded as special one and is not subject to the Register survey.

The use of anchor arrangement specified in **3.1.1** as a working special arrangement for moving the dredgers and also for holding the dredgers in place in the course of dredging carried out by grabs may be allowed; in so doing the required data characterizing the conditions of work of anchor arrangement elements (the value and degree of dynamics of acting forces, the degree of intensity of work and wear rate of the anchor arrangement elements, etc.) shall be submitted.

3.1.3 For all ships other than fishing vessels, the anchoring equipment shall be selected from Table 3.1.3-1, for fishing vessels – from Table 3.1.3-2.

For fishing vessels, when Equipment Number exceeds 720, the anchoring equipment shall be selected from Table 3.1.3-1 based on Equipment Number determined in compliance with 3.2 in the case of ships of unrestricted service and of restricted area of navigation **R1** and **A-R1** and based on Equipment Number reduced:

by 15 % in the case of ships of restricted areas of navigation **R2**, **A-R2**, **R2-S**, **A-R2-S**, **A-R2-RS**, **B-R3-S**, **B-R3-RS**, **C-R3-S**, **C-R3-RS**, **R3-S**, **R3-RS**;

by 25 % in the case of ships of restricted area navigation **R3** i **R3-IN**, **D-R3-S**, **D-R3-RS** 3 taking into account of the provisions specified in **3.1.4**, **3.3.1**, **3.3.2**, **3.4.1**, **3.4.2**, **3.4.3**, **3.4.7** i **3.4.10**.

Table 3.1.3-1

Equipment Number EN		Bower anchors		Mass of stream anchor, in kg	Chain cables for bower anchors				Stream wire or chain	Tow line		Mooring lines			
Exceeding	Not exceeding	Number	Mass of anchor, in kg		Total length of both chain cables, in m	Diameter			Length, in m	Chain cable breaking load or breaking strength of wire	Length, in m	Minimum breaking strength, in kN	Number	Length of each line, in m	Minimum breaking strength, in kN
						Ordinary (grade 1), in mm	Special quality (grade 2), in mm	Extra special quality (grade 3), in mm							
1	2	3	4	5	6	7	8	9	10	11	12	13	14	15	16
10	15	2	35	-	110	¹⁾	-	-	-	-	-	-	2	30	29
15	20	2	50	-	137,5	¹⁾	-	-	-	-	-	-	2	30	29
20	25	2	65	-	165	¹⁾	-	-	-	-	-	-	2	40	29
25	30	2	80	-	165	11,0	-	-	-	-	-	-	2	50	29
30	40	2	105	35	192,5	11,0	-	-	55	55	120	65	2	50	29
40	50	2	135	45	192,5	12,5	-	-	70	60	150	81	2	60	29
50	70	2	180	60	220	14	12,5	-	80	65	180	98	3	80	37
70	90	2	240	80	220	16	14	-	85	74	180	98	3	100	40

90	110	2	300	100	247,5	17,5	16	-	85	81	180	98	3	110	42
110	130	2	360	120	247,5	19	17,5	-	90	89	180	98	3	110	48
130	150	2	420	140	275	20,5	17,5	-	90	98	180	98	3	120	53
150	175	2	480	165	275	22	19	-	90	108	180	98	3	120	59
175	205	2	570	190	302,5	24	20,5	-	90	118	180	112	3	120	64
205	240	2	660	-	302,5	26	22	20,5	-	-	180	129	4	120	69
240	280	2	780	-	330	28	24	22	-	-	180	150	4	120	75
280	320	2	900	-	357,5	30	26	24	-	-	180	174	4	140	80
320	360	2	1020	-	357,5	32	28	24	-	-	180	207	4	140	85
360	400	2	1140	-	385	34	30	26	-	-	180	224	4	140	96
400	450	2	1290	-	385	36	32	28	-	-	180	250	4	140	107
450	500	2	1440	-	412,5	38	34	30	-	-	180	276	4	140	117
500	550	2	1590	-	412,5	40	34	30	-	-	190	306	4	160	134
550	600	2	1740	-	440	42	36	32	-	-	190	338	4	160	143
600	660	2	1920	-	440	44	38	34	-	-	190	371	4	160	160
660	720	2	2100	-	440	46	40	36	-	-	190	406	4	160	171
720	780	2	2280	-	467,5	48	42	36	-	-	190	441	4	170	187
780	840	2	2460	-	467,5	50	44	38	-	-	190	480	4	170	202
840	910	2	2640	-	467,5	52	46	40	-	-	190	518	4	170	218
910	980	2	2850	-	495	54	48	42	-	-	190	559	4	170	235
980	1060	2	3060	-	495	56	50	44	-	-	200	603	4	180	250
1060	1140	2	3300	-	495	58	50	46	-	-	200	647	4	180	272
1140	1220	2	3540	-	522,5	60	52	46	-	-	200	691	4	180	293
1220	1300	2	3780	-	522,5	62	54	48	-	-	200	738	4	180	309
1300	1390	2	4050	-	522,5	64	56	50	-	-	200	786	4	180	336
1390	1480	2	4320	-	550	66	58	50	-	-	200	836	4	180	352
1480	1570	2	4590	-	550	68	60	52	-	-	220	888	5	190	352
1570	1670	2	4890	-	550	70	62	54	-	-	220	941	5	190	362
1670	1790	2	5250	-	577,5	73	64	56	-	-	220	1024	5	190	384
1790	1930	2	5610	-	577,5	76	66	58	-	-	220	1109	5	190	411
1930	2080	2	6000	-	577,5	78	68	60	-	-	220	1168	5	190	437
2080	2230	2	6450	-	605	81	70	62	-	-	240	1259	2)	200	2)
2230	2380	2	6900	-	605	84	73	64	-	-	240	1356	2)	200	2)
2380	2530	2	7350	-	605	87	76	66	-	-	240	1453	2)	200	2)
2530	2700	2	7800	-	632,5	90	78	68	-	-	260	1471	2)	200	2)
2700	2870	2	8300	-	632,5	92	81	70	-	-	260	1471	2)	200	2)
2870	3040	2	8700	-	632,5	95	84	73	-	-	260	1471	2)	200	2)
3040	3210	2	9300	-	660	97	84	76	-	-	280	1471	2)	200	2)
3210	3400	2	9900	-	660	100	87	78	-	-	280	1471	2)	200	2)
3400	3600	2	10500	-	660	102	90	78	-	-	280	1471	2)	200	2)
3600	3800	2	11100	-	687,5	105	92	81	-	-	300	1471	2)	200	2)
3800	4000	2	11700	-	687,5	107	95	84	-	-	300	1471	2)	200	2)
4000	4200	2	12300	-	687,5	111	97	87	-	-	300	1471	2)	200	2)
4200	4400	2	12900	-	715	114	100	87	-	-	300	1471	2)	200	2)
4400	4600	2	13500	-	715	117	102	90	-	-	300	1471	2)	200	2)
4600	4800	2	14100	-	715	120	105	92	-	-	300	1471	2)	200	2)
4800	5000	2	14700	-	742,5	122	107	95	-	-	300	1471	2)	200	2)
5000	5200	2	15400	-	742,5	124	111	97	-	-	300	1471	2)	200	2)
5200	5500	2	16000	-	742,5	127	111	97	-	-	300	1471	2)	200	2)
5500	5800	2	16900	-	742,5	130	114	100	-	-	300	1471	2)	200	2)

			0												
5800	6100	2	1780 0	–	742,5	132	117	102	–	–	300	1471	2)	200	2)
6100	6500	2	1880 0	–	742,5	–	120	107	–	–			2)	200	2)
6500	6900	2	2000 0	–	770	–	124	111	–	–	Tow lines are not re- quired when ship's length exceeds 180 m		2)	200	2)
6900	7400	2	2150 0	–	770	–	127	114	–	–			2)	200	2)
7400	7900	2	2300 0	–	770	–	132	117	–	–			2)	200	2)
7900	8400	2	2450 0	–	770	–	137	122	–	–			2)	200	2)
8400	8900	2	2600 0	–	770	–	142	127	–	–			2)	200	2)
8900	9400	2	2750 0	–	770	–	147	132	–	–			2)	200	2)
9400	1000 0	2	2900 0	–	770	–	152	132	–	–			2)	200	2)
10000	1070 0	2	3100 0	–	770	–	–	137	–	–			2)	200	2)
10700	1150 0	2	3300 0	–	770	–	–	142	–	–			2)	200	2)
11500	1240 0	2	3550 0	–	770	–	–	147	–	–			2)	200	2)
12400	1340 0	2	3850 0	–	770	–	–	152	–	–			2)	200	2)
13400	1460 0	2	4200 0	–	770	–	–	157	–	–			2)	200	2)
14600	1600 0	2	4600 0	–	770	–	–	162	–	–		2)	200	2)	
1) Chain cables or wire ropes may be used, chain cable breaking load or breaking strength of wire rope being not less than 44 kN.															
2) Refer to 2.1.2 of IACS recommendation No.10 (Corr.1 Dec 2016).															

Table 3.1.3-2

Equipment Number EN		Bower anchors		Chain cables for bower anchors			Mooring lines		
Exceeding	Not exceeding	Number	Mass per. anchor, in kg	Total length, in mm	Diameter		Number	Length of each line, in m	Minimum breaking strength, in kN
					grade 1, in mm	grade 2, in mm			
1	2	3	4	5	6	7	8	9	10
10	15	1	30	55	1)	–	2	30	29
15	20	1	40	55	1)	–	2	30	29
20	25	1	50	82,5	1)	–	2	40	29
25	30	1	60	82,5	1)	–	2	50	29
30	40	2	80	165	11,0	–	2	50	29
40	50	2	100	192,5	11,0	–	2	60	29
50	60	2	120	192,5	12,5	–	2	60	29
60	70	2	140	192,5	12,5	–	2	80	29
70	80	2	160	220	14	12,5	2	100	34
80	90	2	180	220	14	12,5	2	100	37
90	100	2	210	220	16	14	2	110	37
100	110	2	240	220	16	14	2	110	39
110	120	2	270	247,5	17,5	16	2	110	39
120	130	2	300	247,5	17,5	16	2	110	44
130	140	2	340	275	19	17,5	2	120	44

140	150	2	390	275	19	17,5	2	120	49
150	175	2	480	275	22	19	2	120	54
175	205	2	570	302,5	24	20,5	2	120	59
205	240	2	660	302,5	26	22	2	120	64
240	280	2	780	330	28	24	3	120	71
280	320	2	900	357,5	30	26	3	140	78
320	360	2	1020	357,5	32	28	3	140	86
360	400	2	1140	385	34	30	3	140	93
400	450	2	1290	385	36	32	3	140	100
450	500	2	1440	412,5	38	34	3	140	108
500	550	2	1590	412,5	40	34	4	160	113
550	600	2	1740	440	42	36	4	160	118
600	660	2	1920	440	44	38	4	160	123
660	720	2	2100	440	46	40	4	160	128

¹⁾ Chain cables or wire ropes may be used, chain cable breaking load or breaking strength of wire rope being not less than 44 kN.

3.1.4 For non-propelled ships the anchoring equipment shall be selected based on Equipment Number increased by 25 % as against that calculated in compliance with provisions specified in **3.1.3** of this Part of the Rules. For self-propelled ships having the maximum ahead speed not more than 6 knots at the draught to the summer load waterline, the anchoring equipment shall be selected as in the case of non-propelled ships.

The anchor arrangement of shipborne barges and berth-connected ships shall comply with the requirements of Directive (EU) 2016/1629 (ES-TRIN) with amendments. For the case of sea passage of berth-connected ships having no permanent anchor arrangement, provision shall be made for anchors and anchor chains to be arranged on board.

For non-propelled ships, the anchor arrangement may not be provided. In this case, for temporary holding of the non-propelled ships, the towing ship anchor arrangement may be considered. At that, technical background for ensuring holding anchorage under stormy conditions including Equipment Numbers for supply vessels, safety factors, environmental effects and loads, shall be submitted to the Register.

For non-propelled ships, the position mooring system may be used as anchor arrangement.

3.1.5 For remote control systems of the anchor arrangements, if any, the type, extent of automated control and scope of remote control operations are determined by the shipowner.

The additional requirements for the remote-controlled anchor arrangements are given in **3.6.5** of this Part, **6.3.6**, Part IX "Machinery", and also in **5.1.3**, Part XI "Electrical Equipment".

3.2 EQUIPMENT NUMBER

3.2.1 The Equipment Number EN for all ships other than floating cranes and tugs, is determined by the formula

$$EN = \Delta^{2/3} + 2Bh + 0,1A, \quad (3.2.1-1)$$

where: Δ – moulded displacement, in t, to the summer load waterline³;

B – breadth of the ship, in m;

h – effective height, in m, from the summer load waterline to the top of the uppermost deckhouse; for the lowest tier h shall be measured at centreline from the upper deck or from a notional deck line where there is local discontinuity in the upper deck, refer to Fig. 3.2.1 for an example, which is determined by the formula:

$$h = a + \sum h_i, \quad (3.2.1-2)$$

where: a – distance, in m, from the summer load waterline amidships to the top of the upper deck plating at side;

h_i – height, in m, at the centreline of each tier of superstructures or deckhouses having a breadth greater than 0,25 B .

In case of ships with two or more superstructures or deckhouses along the length, only one superstructure or deckhouse of the considered tier with the greatest breadth is taken into account.

For the lowest tier h_i shall be measured at the centreline from the upper deck or, in case of a stepped upper deck, from a notional line which is a continuation of the upper deck. When calculating h , sheer and trim shall be ignored. Refer also to **3.2.3**;

A – side-projected area, in m², of the hull, superstructures and deckhouses above the summer load waterline which are

within the ship's length L and also have a breadth greater than $0,25B$ (refer also to 3.2.3).



Рис. 3.2.1

3.2.2. The Equipment Number EN for tugs is determined by the formula

$$EN = \Delta^{2/3} + 2(Ba + \sum h_i b_i) + 0,1A, \quad (3.2.2)$$

where: Δ , B , a , h_i and A are taken according to 3.2.1;

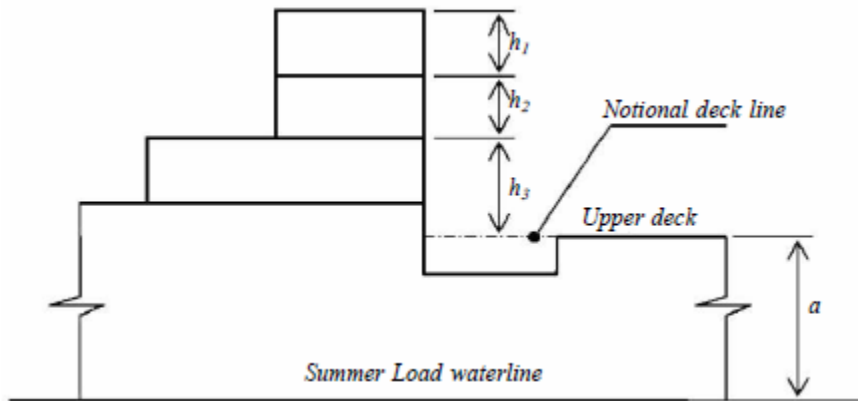
b_i – breadth of the appropriate tier of superstructure or deckhouse, in m. In case of ships with two or more superstructures or deckhouses along the length, the relevant provisions of 3.2.1 shall be followed 3.2.1.

3.2.3 Containers or other similar cargoes carried on decks and on hatchway covers, masts, derrick booms, rigging, guard rails and other similar structures may be ignored when determining h and A ; bulwarks and hatch coamings less than 1,5 m in height may also be ignored. Screens, bulwarks and hatch coamings more than 1,5 m in height shall be regarded as deckhouses or superstructures.

Main galleys, ladders and pile drivers for lifting the ladders of dredgers may be ignored when determining h ; when determining the value A , the side-projected area of these structures shall be calculated as the area limited by the contour of the structure.

3.2.4 The Equipment Number EN for floating cranes is determined by the formula:

$$EN = 1,5\Delta^{2/3} + 2Bh + 2S + 0,1A, \quad (3.2.4)$$

where: Δ , B , h and A are taken according to 3.2.1; when determining the value of A , account shall be taken of the sideprojected area of the upper structure of floating crane (stowed for sea) which is calculated as the area limited by the outer contour of the structure;

S – projection on the mid-section of the front area, in m^2 , of the upper structure of the floating crane (stowed for sea) situated above the deck of the uppermost deckhouse taken into account in determination of h , the front area being determined, in this case, as the area limited by the outer contour of the structure.

3.2.5 For ships with an equipment length of not less than 135 m and intended to anchor in deep and unsheltered water, the anchoring equipment shall be selected according to 1.2 of IACS recommendation No. 10 (Corr.1 Dec 2016).

3.3 BOWER AND STREAM ANCHORS

3.3.1 The mass and number of anchors shall be selected in accordance with 3.1.3. Anchors of the following types are permitted to be used in ships:

- 1 ordinary stockless anchors and stock anchors (Hall's, Gruson's, admiralty anchors);
- 2 high holding power (HHP) anchors;
- 3 super high holding power (SHHP) anchors in accordance with **3.3.4**.

Ships with Equipment Number of 205 and less may have the second bower anchor as a spare one on condition that provision is made for its quick getting ready for use.

Ships of restricted area of navigation **R3, R3-IN** with Equipment Number of 35 and less, if they are not passenger ships, may have only one bower anchor.

3.3.2 Ships of restricted areas of navigation **R2-S, R2-RS, A-R2-S, A-R2-RS, R3-RS, R3-S, B-R3-S, B-R3-RS, C-R3-S, C-R3-RS** and **D-R3-S, D-R3-RS** with Equipment Number in excess of 205 except the values stated in Table 3.1.3-1, shall be equipped with a stream anchor whose mass is at least 75 % of that required for a bower anchor.

For ships of restricted area of navigation **R3, R3-IN** stream anchor may be omitted.

In case the installation of stream anchors on board will affect the proper operation of the ship according to its intended purpose, a stream anchor may be omitted.

3.3.3 When HPP anchors of proven superior holding power are used as bower anchors, the mass of each anchor shall be 75 % of the mass required for ordinary stockless bower anchors in Table 3.1.3-1 or 3.1.3-2. When SHHP anchor of proven holding power are used as bower anchors, the mass of each anchor shall be reduced to not less than 50 % of the mass required for ordinary stockless bower anchors in Table 3.1.3-1 or 3.1.3-2. For fishing vessels with Equipment Number up to 980, where anchor chain cable is replaced with ropes, the mass of the anchor shall be increased by 25 % of the mass of the chosen anchor type.

For approval and/or acceptance as a HPP anchor satisfactory full scale tests in accordance with A1.4.2 of IACS UR A1 shall be done confirming that the anchor has a holding power at least twice that of an ordinary stockless anchor of the same mass.

For approval and/or acceptance as a SHPP anchor satisfactory full scale tests in accordance with A1.4.2 of IACS UR A1 shall be done confirming that the anchor has a holding power at least four times that of an ordinary stockless anchor of the same mass. Similar full scale tests shall be done for HPP anchor confirming that the SHHP anchor has a holding power at least twice that of a previously approved HPP anchor of the same mass.

The scope and procedure for such tests are specified in A1.4.2 of IACS UR A1.

3.3.4 SHHP anchors are suitable for use in ships of restricted areas of navigation **R2, A-R2, R2-S, R2-RS, A-R2-S, A-R2-RS, B-R3-S, B-R3-RS, C-R3-S, C-R3-RS, R3-S, R3-RS, R3, R3-IN, D-R3-S, D-R3-RS**.

The SHHP anchor mass shall not generally exceed 1500 kg.

3.4 CHAIN CABLES AND ROPES FOR BOWER ANCHORS

3.4.1 Ship's with Equipment Number 205 and less, in which the second bower anchor is permitted to be a spare one, and also ships with Equipment Number 35 and less and provided according to **3.3.1** with only one bower anchor may be equipped with only one chain cable the length of which is two times less than that required in the relevant Equipment Table for two chain cables. For ships of restricted area of navigation **R3, R3-IN** chain cables or wire ropes for a stream anchor may be omitted.

3.4.2 For ships having a descriptive notation Supply vessel in their class notation, the total length of both chain cables for bower anchors shall be taken 165 m greater than the value specified in Table 3.1.3-1, and the diameter of these chain cables shall be taken not less than that given in Table 3.1.3-1 two lines below the Equipment Number for the considered ship (having regard to the provisions of **3.1.3** and **3.1.4**).

For supply vessels having a distinguishing mark for ships fitted with a dynamic positioning system in their class notation, this requirement may be waived.

For supply vessels having Equipment Number over 720 at the specification depth of the anchorage over 250 m and for those having Equipment Number 720 and less at the specification depth of the anchorage over 200 m, the length and diameter of chain cables for bower anchors shall be increased taking account of the specification depths and conditions of the anchorage.

3.4.3 For hopper barges and dredgers not having hoppers to transport spoil, the diameter of chain cables for bower anchors shall be taken not less than that specified in Table 3.1.3-1 two lines below the Equipment Number of the considered ship, and for dredgers having hoppers to transport spoil, one line below (taking account of the provisions of **3.1.3** and **3.1.4**).

3.4.4 Chain cables of bower anchors shall be graded dependent on their strength as specified in **7.1**, Part

XIII "Materials".

3.4.5 Tables 3.1.3-1 and 3.1.3-2 specify the diameters of chain cables on the assumption that the links of these chain cables are provided with studs, with the exception of the chain cables less than 15 mm in diameter which are assumed to have no studs.

3.4.6 The chain cables shall be composed of separate chain lengths, except for the chains less than 15 mm in diameter which need not be divided into chain lengths. The lengths of chains shall be interconnected with joining links.

Depending on their location in the chain cable the lengths are divided into:

anchor length fastened to the anchor;

intermediate lengths;

inboard end chain length secured to the chain cable releasing device.

3.4.7 The anchor length of chain shall consist of a swivel, an end link and a minimum quantity of common and enlarged links required to form an independent length of chains.

The anchor length of chains may consist only of a swivel, an end link and a joining link provided the relation between the dimensions of the chain cable parts allows to form such a length. In chain cables which are not divided into lengths of chains the swivel shall be included into each chain cable as near to the anchor as practicable. In all cases, the pins of swivels shall face the middle of the chain cable.

The anchor length shall be connected with the anchor shackle with the aid of an end shackle the pin of which shall be inserted into the anchor shackle.

3.4.8 The intermediate lengths of chains shall be not less than 25 m and not over 27,5 m, the chains consisting of the odd number of links. The total length of two chain cables given in the Equipment Tables is a sum of intermediate lengths of chains only without the anchor and inboard end lengths of chains.

If the number of intermediate lengths of chains is odd, the starboard chain cable shall have one intermediate length of chains more than the port chain cable.

3.4.9 The inboard end length of chains shall consist of a special link of enlarged size (provided, however, that this link is capable of passing freely through the wildcat of the anchor machinery) being secured to the chain cable releasing device, and of minimum number of common and enlarged links required for forming an independent chain length. The inboard end length of chains may consist of one end link only provided the relation between the dimensions of the chain cable parts and the chain cable releasing device allows to form such a length.

3.4.10 In all other respects, the chain cables for bower anchors shall comply with the requirements of **7.1**, Part XIII "Materials".

3.4.11 For ships under 40 m in length the chain cables may be replaced with wire ropes.

For fishing vessels with Equipment Number up to 980, independently of their length, chain cables may be replaced with ropes, taking account of the requirements of **3.3.3**.

Minimum breaking strength of such ropes shall be not less than the breaking load of the corresponding chain cables, and the length shall be at least 1,5 times the length of chain cables.

Wire ropes of trawl winches complying with this requirement may be used as anchor cables.

Ships having Equipment Number 130 and less may be equipped with synthetic fibre ropes instead of chain cables or wire ropes.

3.4.12 The end of each wire rope shall be spliced into a thimble, clamp or socket and connected to the anchor by means of a chain cable section having a length equal to the distance between the anchor (in stowed for sea position) and the anchor machinery or 12,5 m, whichever is the less; a breaking load of the above chain section shall be not less than the breaking strength of the wire rope. The chain cable section shall be secured to the wire rope fitting and the anchor shackle by means of joining shackles being equal to the wire ropes in strength.

The length of the chain cable sections may be included into 1,5 times the length of wire ropes specified in **3.4.11**.

3.4.13 The wire ropes for anchors shall have at least 114 wires and one natural fibre core. The wires of the ropes shall have a zinc coating according to recognized standards. In all other respects, the wire ropes for anchors shall meet the requirements of **3.15**, Part XIII "Materials".

3.5 CHAIN CABLE OR WIRE ROPE FOR STREAM ANCHOR

3.5.1 Stream anchor chain cables shall meet the applicable requirements of **3.4**.

Ships of restricted areas of navigation **R2-S**, **R2-RS**, **A-R2-S**, **A-R2-RS**, **B-R3-S**, **B-R3-RS**, **C-R3-S**, **C-R3-RS** and **D-R3-S**, **D-R3-RS** with Equipment Number in excess of 205 shall be equipped with a stream

anchor chain cable whose length is at least 60 % of that required for a bower anchor chain cable. The chain cable diameter shall be taken not less than that mentioned in Table 3.1.3-1 two lines above the Equipment Number of the ship in question (taking into account **3.1.3** and **3.1.4**).

Ships having Equipment Number below 205 may be equipped with studless chain cables.

3.5.2 The requirements of **3.4.12** and **3.4.13** are applicable to the wire rope for the stream anchor.

3.6 ANCHOR APPLIANCES

3.6.1 Stoppers.

3.6.1.1 Each bower anchor chain cable or rope and each stream anchor chain cable having a mass of 200 kg and above shall be provided with a stopper holding the anchor in the hawse pipe when stowed for sea or, in addition, intended for riding the ship at anchor.

In ships having no anchor machinery or having the anchor machinery, which is not in compliance with the requirements of **6.3.2.3.2**, Part IX "Machinery" provision of stoppers for riding the ship at anchor is obligatory.

3.6.1.2 Where the stoppers is intended only for securing the anchor in the hawse pipe when stowed for sea, its parts shall be calculated to withstand the chain cable strain equal to twice the weight of the anchor, the stresses in the stopper parts not exceeding 0,4 times the upper yield stress of their material. Where the stopper comprises a chain cable or rope, this shall have safety factor 5 in relation to the breaking load of the chain cable or minimum breaking strength of the rope under the action of a force equal to twice the weight of the anchor.

3.6.1.3 Where the stopper is intended for riding the ship at anchor, its parts shall be calculated on assumption that the stopper will be subjected to a force in the chain cable equal to 0,8 times its breaking load. The stresses in the stopper parts shall not exceed 0,95 times the upper yield stress of their material. Where the stopper comprises a chain cable or rope, they shall have strength equal to that of the chain cable for which they are intended.

3.6.1.4 In fiber-reinforced plastic ships the stoppers shall be fastened by bolts with the use of steel gaskets or wooden pads on the deck and under deck flooring between the framing. Bolt connections shall comply with the requirements of **1.7.4**, Part XVI "Structure and Strength of Fiber-Reinforced Plastic Ships".

3.6.2 Device for securing and releasing the inboard end of the chain cable.

3.6.2.1 The parts of the device for securing and releasing the inboard end of the chain cable shall be calculated for strength under the force acting on the device which is equal to 0,6 times the chain breaking load, stresses in these parts not exceeding 0,95 times the upper yield stress of their material.

3.6.2.2 In ships with Equipment Number of more than 205 the device for securing and releasing the inboard end of the chain cable shall be provided with a drive from the deck on which the anchor machinery is fitted or from other deck, in a place which gives quick and ready access at all times. The screw of the drive shall be self-braking.

3.6.2.3 The design of the device for securing and releasing the inboard end of the chain cable shall ensure the efficiency of its operation both under the action of and without the strain of the chain cable referred to in **3.6.2.1**.

3.6.2.4 In fiber-reinforced plastic ships the device for securing and releasing the inboard end of the chain cable shall be fastened by bolts with the use of steel gaskets on both sides of the bulkhead. Bolt connections shall comply with the requirements of **1.7.4**, Part XVI "Structure and Strength of Fiber-Reinforced Plastic Ships".

3.6.3 Laying of chain cables.

3.6.3.1 Laying of chain cables shall provide for their free run when dropping or hoisting the anchors.

In ships with a bulbous bow laying of chain cables shall comply with the requirements of **2.8.2.4**, Part II "Hull".

3.6.3.2 The anchor shank shall easily enter the hawse pipe under the mere action of the chain cable tension and shall readily take off the hawse pipe when the chain cable is released.

3.6.3.3 The thickness of the hawse pipe shall not be less than 0,4 times the diameter of the chain cable passing through the hawse pipe.

3.6.3.4 In fiber-reinforced plastic ships galvanized or stainless steel plates shall be fitted on the outside plating under the hawse pipes; the plates shall be fastened by countersunk bolts. Bolt connections shall comply with the requirements of **1.7.4**, Part XVI "Structure and Strength of Fiber-Reinforced Plastic Ships".

3.6.4 Chain lockers.

3.6.4.1 For stowage of each bower anchor chain lockers shall be provided.

When one chain locker is designed for two chains, it shall be provided with an internal permeable or watertight division so that separate stowage of each chain is ensured.

3.6.4.2 The chain locker shall be of shape, capacity and depth adequate to provide an easy direct lead of the cables through the chain pipes, an easy self-stowing of the cables and their free veering away when dropping the anchors.

3.6.4.3 The chain locker design, as well as chain and hawse pipes shall be watertight up to the weather deck. Upper openings of such pipes shall be fitted with the permanent buckler plates. These may be made both of steel with the relevant cutouts for a chain cable diameter and of canvas with the relevant fastenings to keep the plate closed down.

The openings for access to the chain locker shall be fitted with covers secured with closely spaced bolts.

3.6.4.4 Drainage of chain lockers shall comply with the requirements in 7.12.1, Part VIII "Systems and Piping", and lighting - with the requirements of 6.7, Part XI "Electrical Equipment".

3.6.5 Additional requirements for remote-controlled anchor appliances.

3.6.5.1 Stoppers and other anchor appliances for which remote control is provided (refer to 3.1.5) shall also be fitted with means of local manual control.

3.6.5.2 The anchor appliances and the associated means of local manual control shall be so designed that normal operation is ensured in case of failure of separate elements or the whole of the remote control system (refer also to 5.1.3, Part XI "Electrical Equipment").

3.7 ANCHOR MACHINERY

3.7.1 Anchor machinery shall be fitted on the deck in the fore part of the ship for dropping and hoisting the anchors, as well as for holding the ship with the bower anchors dropped if the mass of the anchor exceeds 35 kg.

Ships of restricted area of navigation **R2-S, R2-RS, A-R2-S, A-R2-RS, B-R3-S, B-R3-RS, C-R3-S, C-R3-RS** and **D-R3-S, D-R3-RS**, shall be fitted with the anchor machinery for dropping and hoisting the stream anchor if its mass exceeds 200 kg.

Ships having Equipment Number 205 and less may be fitted with hand-operated anchor machinery and may also use other deck machinery for dropping and hoisting the anchors.

The requirements for the design and power of anchor machinery are given in 6.3, Part IX "Machinery".

In fiber-reinforced plastic ships fastening of the anchor machinery shall comply with the requirements of 3.6.1.4.

3.8 SPARE PARTS

3.8.1 Each ship carrying a spare anchor and equipped with a chain cable (cables) for bower anchor (anchors) accordance with the provisions of 3.3.1 and 3.4 shall have: spare anchor length of chain - 1 pc, spare joining link - 2 pcs, spare end shackle - 1 pc.

3.8.2 Each ship equipped with a spare anchor and wire rope (ropes) for bower anchor (anchors) in accordance with the provisions of 3.3.1 and 3.4.11 shall have a spare set of parts for joining the wire rope and anchor shackle.

4. MOORING ARRANGEMENT

4.1 GENERAL

4.1.1 Each ship shall be supplied with mooring arrangement for warping to coastal or floating berths and for reliable fastening of the ship to them. For shipborne barges the mooring arrangement shall comply with the requirements of Directive (EU) 2016/1629 (ES-TRIN) with amendments.

For shipboard fittings not selected from an industry standard accepted (approved) by the Register, the corrosion addition, t_c and the wear allowance t_w , given in 4.3.5, respectively, shall be considered.

The requirements of this Section for selection of mooring arrangement do not apply to oil tankers of 150 m in length and above as well as bulk carriers of 90 m in length and above, contracted for construction on or

after 1 July 2015. The requirements for mooring lines and mooring arrangements of the said ships are regulated by the IACS Common Structural Rules for Bulk Carriers and Oil Tankers.

4.1.2 For all ships other than fishing vessels, the number, length and minimum breaking strength of mooring lines shall be as recommended values given in Table 3.1.3-1, and for fishing values – in Table 3.1.3-2.

For fishing vessels, when Equipment Number exceeds 720, the number, length and minimum breaking strength of mooring lines, given as recommended values, shall be selected from Table 3.1.3-1 based on Equipment Number determined in compliance with **3.2**.

4.1.3 For ships with Equipment Number EN of less than or equal to 2000 and having the ratio A/EN more than 0,9, the following number of mooring lines shall be added to the number of mooring lines as given by Table 3.1.3-1:

one line where $0,9 < A/N_s \leq 1,1$;

two lines where $1,1 < A/N_s \leq 1,2$;

three lines where $A/N_s > 1,2$,

where EN and A = Equipment Number and side-projected area, respectively, specified in **3.2**.

For ships with an Equipment Number $EN > 2000$, the mooring lines may be selected according to **2.1.2** of IACS recommendation No. 10 (Corr.1 Dec 2016).

4.1.4 For individual mooring lines with breaking strength above 490 kN according to Table 3.1.3-1 the latter may be reduced with corresponding increase of the number of mooring lines, provided that the total breaking strength of all mooring lines aboard the ship is not less than the value selected from Table 3.1.3-1 with regard to **4.1.3** and **4.1.6**. The number of lines shall be not less than 6 and none of the lines shall have the breaking strength less than 490 kN.

4.1.5 The length of individual mooring lines may be reduced by up to 7 % as against the prescribed value provided that the total length of all mooring lines is not less than that specified in Table 3.1.3-1 and **4.1.3** or Table 3.1.3-2.

4.1.6 In case mooring line made of synthetic fibre material is used, its actual breaking strength F_s , in kN, shall not be less than determined by the formula

$$F_s = 0,0742 \delta_m F_t^{8/9} \quad (4.1.6)$$

where δ_m = mean elongation at breaking of a synthetic fibre rope, in %, but not less than 30 %.

Where no data on δ_m are available, it shall be assumed equal to:

45 % for polyamide ropes;

35 % for polypropylene ropes;

F_t = minimum breaking strength of the mooring line specified in Table 3.1.3-1 or 3.1.3-2, in kN.

4.2 MOORING LINES

4.2.1 Mooring lines may be of steel wire, natural fibre or synthetic fibre material, with the exception of the lines intended for ships carrying in bulk flammable liquids with the flash point 60 8C and below. In these ships the operations with steel wire ropes are allowed only on the superstructure decks which are not the top of liquid cargo tanks and on condition that no pipelines for loading and unloading the cargo are carried through these decks.

Notwithstanding the breaking strength specified in Tables 3.1.3-1 or 3.1.3-2 or determined by Formula (4.1.6), the diameter of the mooring rope made from natural or synthetic fibre material shall not be less than 20 mm.

4.2.2 Steel wire ropes shall have at least 144 wires and not less than 7 fibre cores. The exception is made for wire ropes for automatic mooring winches which may have only one fibre core but the number of wires in such ropes shall be not less than 216. The wires of the ropes shall have a zinc coating according to recognized standards.

In all other respects, the steel wire ropes shall meet the requirements of **3.15**, Part XIII "Materials".

4.2.3 Natural fibre ropes shall be either manilla or sizar. The ships having Equipment Number 205 and

less are permitted to use hemp ropes. In all other respects, the natural fibre ropes shall meet the requirements of 6.6, Part XIII "Materials".

4.2.4 The synthetic fibre ropes shall be manufactured from approved homogeneous materials (polypropylene, capron, nylon, etc.).

In all other respects, the ropes of synthetic fibre material shall meet the requirements of 6.6, Part XIII "Materials".

4.3 MOORING EQUIPMENT

4.3.1 The number and position of mooring bollards, fairleaders and other mooring equipment depend on the constructional features, purpose and general arrangement of the ship.

Shipboard fittings may be selected from an industry standard accepted (approved) by the Register in accordance with recommended minimum breaking strength of the mooring lines selected from Table 3.1.3-1.

When the shipboard fitting is not selected from an accepted (approved) industry standard, the strength of the fitting and of its attachment to the ship shall be in accordance with 4.3.4 and 4.3.5.

Mooring bitts (double bollards) are required to resist the loads caused by the mooring line attached in figure-of-eight fashion (refer to Note). For strength assessment beam theory or finite element analysis using net scantlings (without corrosion additions and wear down allowances specified in 4.3.5) shall be applied, as appropriate. Load tests may be accepted as alternative to strength assessment by calculations.

Note. With the line attached to a mooring bitt in the usual way (figure-of-eight fashion), either of the two posts of the mooring bitt can be subjected to a force twice as large as that acting on the mooring line. Disregarding this effect, depending on the applied industry standard and fitting size, overload may occur.

4.3.2 Bollards may be of steel or cast iron. Small ships equipped only with natural fibre or synthetic fibre ropes are permitted to use the bollards made of light alloys. As to the method of manufacture, the bollards may be welded or cast.

It is not permitted to use bollards cut directly in the deck which is the top of cargo tanks intended for carriage or stowage of flammable liquids with the flash point 60 8C and below.

4.3.3 The outside diameter of the bollard column shall be not less than 10 diameters of the steel wire rope, not less than 5,5 diameters of the synthetic fibre rope, and not less than one circumference of the natural fibre rope for which the bollard is designed. The distance between the axes of bollard columns shall not be less than 25 diameters of the steel wire rope or 3 circumferences of the natural fibre rope.

4.3.4 Shipboard fittings, winches and capstans for mooring shall be located on stiffeners and/or girders, which are part of the deck construction so as to facilitate efficient distribution of the mooring load.

4.3.4.1 The minimum design load applied to supporting hull structures for shipboard fittings shall be 1,15 times the minimum breaking strength of the mooring line according to Table 3.1.3-1.

4.3.4.2 The minimum design load applied to supporting hull structures for winches shall be 1,25 times the intended maximum brake holding load, where the maximum brake holding load shall be assumed not less than 80 % of the minimum breaking strength of the mooring line according to Table 3.1.3-1; for supporting hull structures of capstans, 1,25 times the maximum hauling-in force shall be taken as the minimum design load.

4.3.4.3 When a safe working load (SWL) greater than that determined according to 4.3.6 is specified by the designer/shipowner, then the design load shall be increased accordingly. **4.3.4.4** The design load shall be applied to fittings in all directions that may occur by taking into account the arrangement shown on the towing and mooring arrangements plan.

However, in no case does the design load applied to the fitting need to be greater than twice the design load on the line.

Note. 1. If not otherwise specified by IACS recommendation No. 10, side-projected area including that of deck cargoes as given by the Loading Manual shall be taken into account for selection of mooring lines and the loads applied to shipboard fittings and supporting hull structure.

2. The increase of the minimum breaking strength for synthetic ropes according to IACS recommendation No. 10 needs not to be taken into account for the loads applied to shipboard fittings and supporting hull structure.

The arrangement of reinforced members beneath shipboard fittings, winches and capstans shall consider any variation of direction (horizontally and vertically) of the mooring forces acting upon the shipboard fittings, refer to Fig. 5.3.6. Proper alignment of fitting and supporting hull structure shall be ensured.

The acting point of the mooring force on shipboard fittings shall be taken at the attachment point of a mooring line or at a change in its direction. For bollards and bitts the attachment point of the mooring line shall be taken not less than $4/5$ of the tube height above the base, refer to Fig. 4.3.4, *a*.

However, if fins are fitted to the bollard tubes to keep the mooring line as low as possible, the attachment point of the mooring line may be taken at the location of the fins, refer to Fig. 4.3.4, *b*.

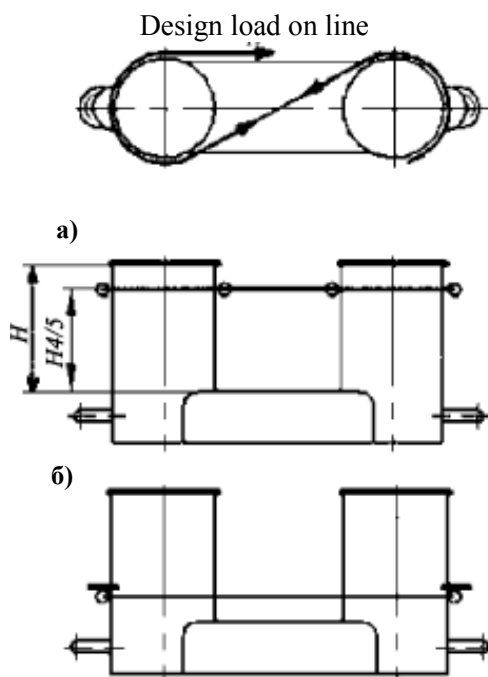

Fig.4.3.4

4.3.5 Allowable stresses in supporting hull structures under the design load conditions as specified in 4.3.4 are as follows:

.1 for strength assessment with beam theory or grillage analysis:

normal stress: 100 % of the specified minimum yield point of the material;

shear stress: 60 % of the specified minimum yield point of the material.

Normal stress is the sum of bending stress and axial stress with the corresponding shear stress acting perpendicular to the normal stress.

No stress concentration factors being taken into account.

.2 for strength assessment with finite element analysis: equivalent stress:

100 % of the specified minimum yield point of the material.

For strength calculations by means of finite elements, the geometry shall be idealized as realistically as possible.

The ratio of element length to width shall not exceed 3. Girders shall be modelled using shell or plane stress elements.

Symmetric girder flanges may be modelled by beam or truss elements.

The element height of girder webs shall not exceed one-third of the web height.

In way of small openings in girder webs the web thickness shall be reduced to a mean thickness over the web height.

Large openings shall be modelled.

Stiffeners may be modelled by using shell, plane stress, or beam elements. Stresses shall be read from the centre of the individual element.

For shell elements the stresses shall be evaluated at the mid plane of the element.

The corrosion addition t_c , shall not be less than the following values: for ships covered by IACS Common Structural Rules for Bulk Carriers and Oil Tankers:

total corrosion addition shall be as defined in these Rules;

other ships: for the supporting hull structure, according to Part II "Hull" for the surrounding structure (e.g. deck structures, bulwark structures);

for pedestals and foundations on deck which are not part of a fitting according to an accepted (approved) industry standard, 2,0 mm;

for shipboard fittings not selected from an accepted (approved) industry standard, 2,0 mm.

Wear allowance:

in addition to the corrosion addition the wear allowance t_w , for shipboard fittings not selected from an accepted (approved) industry standard shall not be less than 1,0 mm, added to surfaces which are intended to regularly contact the line.

4.3.6 SWL of details of mooring appliances shall not exceed 0,8 design load determined in accordance with **4.3.4**.

All details of the mooring appliances shall be marked with the value of SWL by means of welding or other equivalent method.

4.4 MOORING MACHINERY

4.4.1 Special mooring machinery (mooring capstans, mooring winches, etc.) as well as other deck machinery (windlasses, cargo winches, etc.) fitted with mooring drums may be used for warping the hawsers.

4.4.2 The choice of the number and type of mooring machinery is within the owner's and designer's discretion, however, the rated pull of the machinery shall not exceed 1/3 of the breaking strength of the mooring ropes used in the ship and, besides, the requirements of **6.4**, Part IX "Machinery" shall be satisfied.

4.5 TOWING AND MOORING ARRANGEMENTS PLAN

4.5.1 The SWL (Safe Working Load) and TOW (Safe Towing Load) for the intended use for each shipboard fitting shall be noted in the towing and mooring arrangements plan available on board for the guidance of the master.

TOW is the load limit for towing purpose and SWL that for mooring purpose. If not otherwise chosen, for towing bits it should be noted that TOW is the load limit for a towing line attached with eye-splice.

4.5.2 Information provided on the plan shall include in respect of each shipboard fitting:

location on the ship;

fitting type;

SWL/TOW;

purpose (mooring/harbour towing/other towing);

manner of applying towing or mooring line load including limiting fleet angles.

Furthermore, information provided on the plan shall include:

the arrangement of mooring lines showing number of lines (N);

the minimum breaking strength of each mooring line (MBL);

the acceptable environmental conditions as given in IACS recommendation No. 10, for the recommended minimum breaking strength of mooring lines for ships with Equipment Number EN>2000:

30 s mean wind speed from any direction (v_w or v^*_w according to IACS recommendation No. 10); maximum current speed acting on bow or stern ($\pm 10^\circ$).

4.5.3 The information as given in **4.5.2** shall be incorporated into the pilot card in order to provide the pilot proper information on harbour and other towing operations.

5. TOWING ARRANGEMENT

5.1 GENERAL

5.1.1 Each ship shall be provided with towing arrangement which satisfies the requirements of **5.2** and **5.3**.

Besides, the ships having the descriptive notation **Tug** added to the character of classification shall comply with the requirements of **5.4 ÷ 5.6**.

5.1.2 Oil tankers, oil tankers (>60 8C), combination carriers, gas carriers and chemical tankers of 20 000 t deadweight and over shall comply with the requirements of **5.7**.

passenger and cargo ships shall be provided with an emergency towing procedure in accordance with **5.7.11**.

5.1.3 The towing arrangements of berth-connected ships shall comply with the requirements of Directive (EU) 2016/1629 (ES-TRIN) with amendments.

5.1.4 The requirements of this Section for selection of towing arrangement do not apply to oil tankers of 150 m in length and above as well as bulk carriers of 90 m in length and above, contracted for construction on or after 1 July 2015. The requirements for tow lines and towing arrangements of the said ships are regulated by the IACS Common Structural Rules for Bulk Carriers and Oil Tankers.

5.2 TOW LINE

5.2.1 The length and the minimum breaking strength of the tow line shall be as recommended values given in Table 3.1.3-1 based on an Equipment Number calculated in compliance with **3.2**.

For shipborne barges the actual breaking strength of the tow line F_b , in kN, shall be calculated by the formula

$$F_b = 16nBd \quad (5.2.1)$$

where n = number of barges intended to be towed in the wake of the tug in tandem;

B = breadth of the barge, in m;

d = draught of the barge, in m.

The breaking strength of the tow line is used in the strength calculations of the towing appliances of the shipborne barges. At the discretion of the shipowner the tow lines of the shipborne barges may be stored in the barge carrier or tug, and they do not form a part of the equipment of the shipborne barge.

5.2.2 The tow lines may be of steel wire, natural fibre or synthetic fibre material. The requirements of **4.1.6**, **4.2.1** - **4.2.4** for mooring ropes are also applicable to the tow line.

5.3 TOWING EQUIPMENT

5.3.1 The number and location of towing bollards and chocks depend on the constructional features, purpose and general arrangement of the ship.

Ships having the descriptive notation Tug added to the character of classification, and equipped with a bow towing winch with a tow line may have no towing bitts provided the technical characteristics of this winch, its foundation and tow line comply with the requirements of **5.3.3 ÷ 5.3.6**.

5.3.2 Requirements of **4.3.2** and **4.3.3** introduced for the mooring bollards also apply to towing bollards.

5.3.3 Shipboard fittings for towing shall be located on longitudinals, which are part of the deck construction so as to facilitate efficient distribution of the towing load.

5.3.4 The minimum design load applied to supporting hull structures for shipboard fittings shall be:

.1 for normal towing operations - 1,25 times the intended maximum towing load (e.g. static bollard pull) as indicated on the towing and mooring arrangements plan;

.2 for other towing service - the minimum breaking strength of the tow line according to Table 3.1.3-1 for the ship's corresponding Equipment Number;

.3 for fittings intended to be used for, both, normal and other towing operations, the greater of the design

loads according to 5.3.4.1 and 5.3.4.2.

5.3.5 The design load applied to supporting hull structure shall be in accordance with 5.3.4.

The reinforced members beneath shipboard fittings shall be effectively arranged for any variation of direction (horizontally and vertically) of the towing forces acting upon the shipboard fittings, refer to Fig. 5.3.5-1.

Proper alignment of fitting and supporting hull structure shall be ensured.

The acting point of the towing force on shipboard fittings shall be taken at the attachment point of a towing line or at a change in its direction.

For bollards and bitts the attachment point of the towing line shall be taken not less than $4/5$ of the tube height above the base, refer to Fig 5.3.5.2.

For strength assessment using beam theory or grillage analysis, as well as finite element analysis, the stresses in supporting hull structures shall be determined in the same manner as specified in 4.3.5.

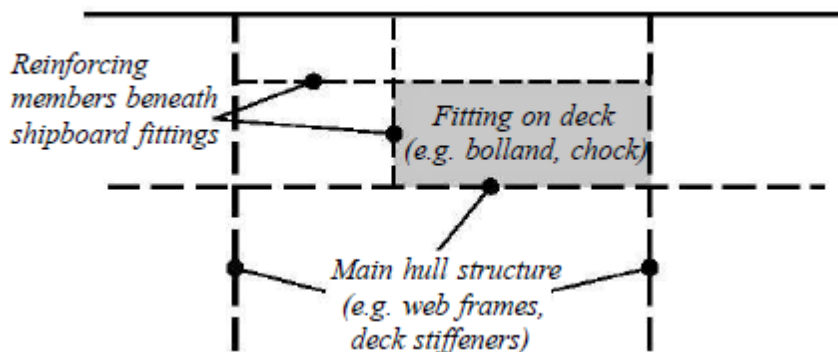

Fig. 5.3.5.1

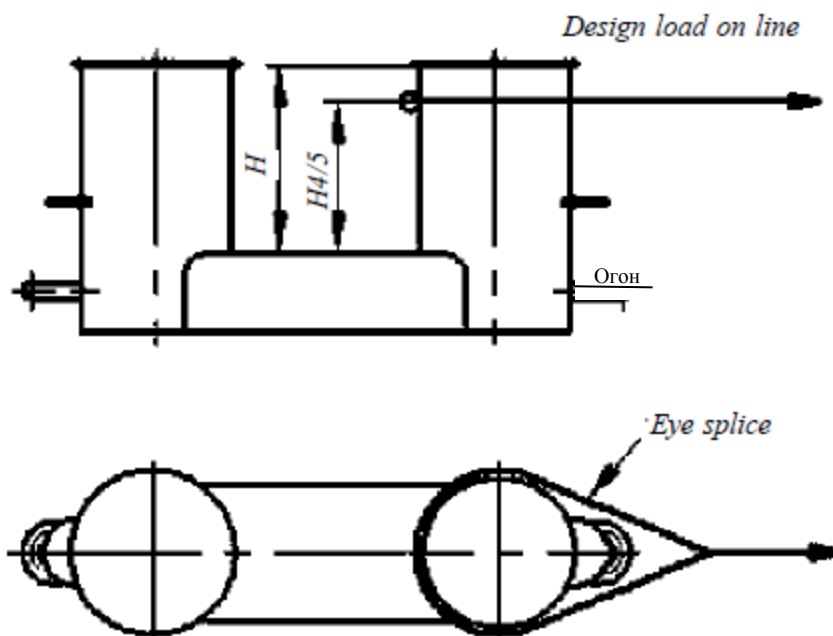

Fig. 5.3.5.2

5.3.6 When a safe towing load (TOW) greater than that determined according to **5.3.8** is specified by the designer/shipowner, then the design load shall be increased in accordance with the appropriate TOW/design load relationship given by **5.3.4** and **5.3.8**.]

The design load shall be applied to fittings in all directions that may occur by taking into account the arrangement shown on the towing and mooring arrangements plan. Where the towing line takes a turn at a fitting the total design load applied to the fitting is equal to the resultant of the design loads acting on the line, refer to Fig. 5.3.6. However, in no case does the design load applied to the fitting need to be greater than twice the design load on the line.

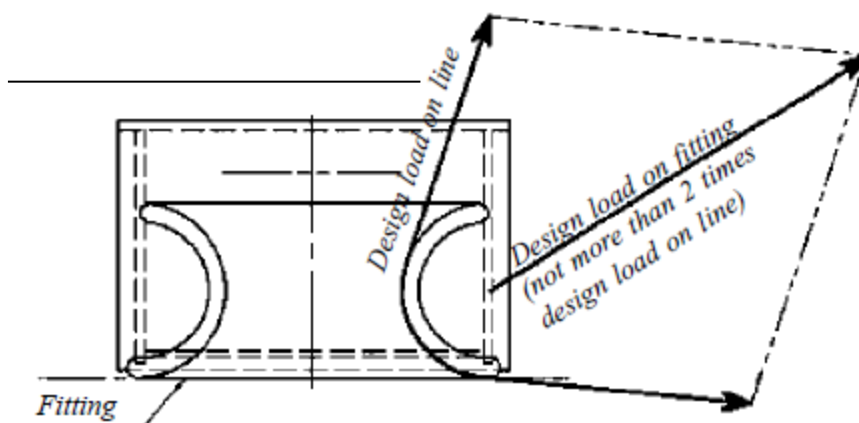

Fig. 5.3.6

5.3.7 Shipboard fittings.

Shipboard fittings may be selected from an industry standard accepted (approved) by the Register and at least based on the following loads:

- 1 for normal towing operations, the intended maximum towing load (e.g. static bollard pull) as indicated on the towing and mooring arrangements plan;
- 2 for other towing service, the minimum breaking strength of the tow line according to IACS recommendation No. 10 (refer to Notes in **4.3.4**);
- 3 for fittings intended to be used for, both, normal and other towing operations, the greater of the loads according to **5.3.7.1** and **5.3.7.2**.

When the shipboard fitting is not selected from an accepted (approved) industry standard, the strength of the fitting and of its attachment to the ship shall be in accordance with **5.3.4** and **5.3.5**.

Towing bits (double bollards) are required to resist the loads caused by the towing line attached with eye splice.

For strength assessment, beam theory or finite element analysis using net scantlings (without corrosion additions and wear down allowances specified in **4.3.5**) shall be applied, as appropriate.

Load tests may be accepted as alternative to strength assessment by calculations.

5.3.8 Safe Towing Load (TOW).

5.3.8.1 TOW is the load limit for towing purpose.

5.3.8.2 TOW used for normal towing operations shall not exceed 80 % of the design load per **5.3.4.1**.

5.3.8.3 TOW used for other towing operations shall not exceed 80 % of the design load according to **5.3.4.2**.

5.3.8.4 For fittings used for both normal and other towing operations, the greater of the safe towing loads according to **5.3.8.2** and **5.3.8.3** shall be used.

5.3.8.5 Fittings intended to be used for, both, towing and mooring, shall comply with the requirements of Section 4.

5.3.8.6 TOW, in t, of each shipboard fitting shall be marked (by weld bead or equivalent) on the deck fittings used for towing. For fittings intended to be used for, both, towing and mooring SWL, in t, shall be marked in addition to TOW.

5.3.8.7 The above requirements on TOW apply for the use with no more than one line.

If not otherwise chosen, for towing bitts (double bollards) TOW is the load limit for a towing line attached with eye-splice.

5.4 SPECIAL ARRANGEMENT FOR TUGS

5.4.1 The number and type of equipment and outfit forming special arrangement for tugs which ensures towing operations under different service conditions are determined by the shipowner considering that such equipment and outfit shall satisfy the requirements of this Chapter.

5.4.2 The main determining factor in providing the tugs with a special arrangement is a bollard pull (BP).

5.4.2.1 The numerical value of the rated towing pull in modes, specified in **5.4.2**, is within the shipowner's and designer's discretion, and all calculations pertaining to the determination of this value are not subject to agreement with the Register. Nevertheless, during mooring and sea trials of the tug, the Register will check this value, and, if the parts of the special arrangement prove to be calculated from a smaller value, the Register may require the strengthening of these parts or may introduce restriction of power during towing operations.

5.4.2.2 Minimum breaking strength (MBL) of the tow line shall be in accordance with Table 5.4.2.2:

Table 5.4.2.2

<i>BP</i> , in t	< 40	40 – 90	> 90
<i>MBL</i> , in t	$3,0 \cdot BP$	$(3,8 - BP / 50) \cdot BP$	$2,0 \cdot BP$

The tow line for towing operations on the hook may be of steel wire, natural fibre or synthetic fibre material. The requirements of **4.2** for mooring lines are also applicable to the tow line for towing operations on the hook.

5.4.3 All stressed parts of the towing arrangement (such as the tow hook, towing rails, etc.) as well as the fastenings for securing these parts to the ship's hull shall be designed to take the breaking load of the tow line. The stresses in these parts shall not exceed 0,95 times the upper yield stress of their material.

5.4.4 The cramp iron of the tow hook shall be calculated as a curvilinear bar. Where such calculations are not carried out, i.e. the formulae for a rectilinear bars are used, permissible stresses shall be reduced by 35 %.

5.4.5 All parts of the towing arrangement which are subjected to tension or bending under the hull of the tow line shall not be manufactured of cast iron.

5.4.6 The cramp iron of the tow hook shall be either solid forged or manufactured of a solid rolled blank. Percentage elongation of the cramp iron material shall not be less than 18 % on a fivefold sample.

5.4.7 Tow hooks shall be of slip-type and have a tow line releasing device operating efficiently in the range of loads on the tow hook from zero to three times the rated towing pull and at any practically possible deflection of the tow line from the centreline of the ship.

The device shall be controlled both at the tow hook and from the navigation bridge. Where the ship is fitted with a spshallw hook, in addition to the main one, this hook need not be of slip-type and have a device for releasing the tow line.

5.4.8 When applying tow hooks with shock absorbers, their ultimate damping load shall not be less than 1,3 times the rated towing pull.

5.4.9 Prior to installation on board the ship the tow hooks shall be tested by application of a proof load equal to twice the rated towing pull.

5.4.10 The wire stopper and its fastenings shall be such that their breaking load is not less than 1,5 times the rated towing pull.

5.4.11 The requirements of **3.7**, Part IV "Stability" shall be taken into consideration when assigning the position of the tow hook and towing winch.

5.5 TOWING WINCHES

5.5.1 The requirements for the design of towing winches are specified in **6.5** and **6.6**, Part IX "Machinery".

5.5.2 Provision shall be made for operating the towing winch from a site at the winch; it is recommended to allow for operating the towing winch from the navigation bridge.

When placing the control station on the navigation bridge at the towing winch and having possibility of supervision for its operation, it is allowed not to provide for operating the towing winch directly from the place of its installation.

5.6 TOW LINE FOR TOWING WINCH

5.6.1 The tow line for towing winch shall be selected by the shipowner depending on the structural particulars and purpose of the ship.

The recommended requirements for tow line for towing winch are given in **5.4.2.2**.

5.7 EMERGENCY TOWING ARRANGEMENTS ON SHIPS

5.7.1 Ships referred to in 5.1.2 shall be fitted with emergency towing arrangements forward and aft of the ship. The arrangements shall be capable of rapid deployment in the absence of main power on the ship to be towed and easy connection to the towing ship. At least one of the emergency towing arrangements shall be pre-rigged ready for rapid deployment.

5.7.2 The components of the emergency towing arrangement are listed in Table 5.7.2.

Table 5.7.2 Emergency towing arrangements.

Components of emergency towing arrangement	Non pre-rigged	Pre-rigged
Pick-up gear	Optional	Yes
Towing pennant	Optional	Yes
Chafing gear	Yes	Depending on design
Fairlead	Yes	Yes
Strongpoint	Yes	Yes
Roller pedestal	Yes	Depending on design

5.7.3 Except the pick-up gear and roller pedestal, the components of the emergency towing arrangement specified in Table 5.7.2 shall have a working strength of at least:

1000 kN for ships of 20 000 t deadweight and over, but less than 50 000 t deadweight,

2000 kN for ships of 50 000 t deadweight and over.

Under the above forces, the stresses shall not exceed 0,5 of the ultimate strength.

The strength shall be sufficient for all relevant angles of towline, i.e. up to 90° from the ship's centreline to port and starboard and 30° vertically downwards.

5.7.4 The towing pennant shall have a length of at least twice the lightest seagoing ballast freeboard at the fairlead plus 50 m. The towing pennant shall have a hard eye-formed termination allowing connection to a standard shackle.

The bow and stern strongpoints and fairleads shall be located so as to facilitate towing from either side of the bow or stern and minimize the stress on the towing system.

The inboard end fastening shall be a stopper or bracket or other fitting of equivalent strength. The strongpoint can be designed integral with the fairlead.

5.7.5 Fairleads shall have an opening large enough to pass the largest portion of the chafing gear, towing pennant or towing line.

The fairlead shall give adequate support for the towing pennant during towing operation which means bending 90° to port and to starboard side and 308 vertically downwards. The bending ratio (towing pennant bearing surface diameter to towing pennant diameter) shall be not less than 7:1.

The fairlead shall be located as close as possible to the deck and, in any case, in such a position that the chafing chain is approximately parallel to the deck when it is under strain between the strongpoint and the fairlead.

5.7.6 The chafing gear shall be fitted at the forward and, depending on design, aft ends of the ship. A chafing chain or another design approved by the Register may be used as the chafing gear. The chafing chain shall be a stud link chain.

The chafing chain shall be long enough to ensure that the towing pennant remains outside the fairlead during the towing operation. A chain extending from the strongpoint to a point at least 3 m beyond the fairlead shall meet this criterion.

5.7.7 One end of the chafing chain shall be suitable for connection to the strongpoint. The other end shall be fitted with a standard pear-shaped open link allowing connection to a standard bow shackle.

The chafing chain shall be stowed in such a way that it can be rapidly connected to the strongpoint.

5.7.8 The pre-rigged pick-up gear shall be designed for manual operation by one person taking into account the absence of power and the potential for adverse environmental conditions that may prevail during such emergency towing operations. The pick-up gear shall be protected against the weather and other adverse conditions that may prevail.

5.7.9 The non pre-rigged emergency towing arrangement shall be capable of being deployed in harbour conditions in not more than 1 h. To facilitate connection of the towing pennant to the chafing gear and to prevent chafing of the pennant, a suitably positioned pedestal roller may be used.

Pre-rigged emergency towing arrangements at both ends of the ship may be accepted.

A type emergency towing arrangement is shown in Fig. 5.7.9.

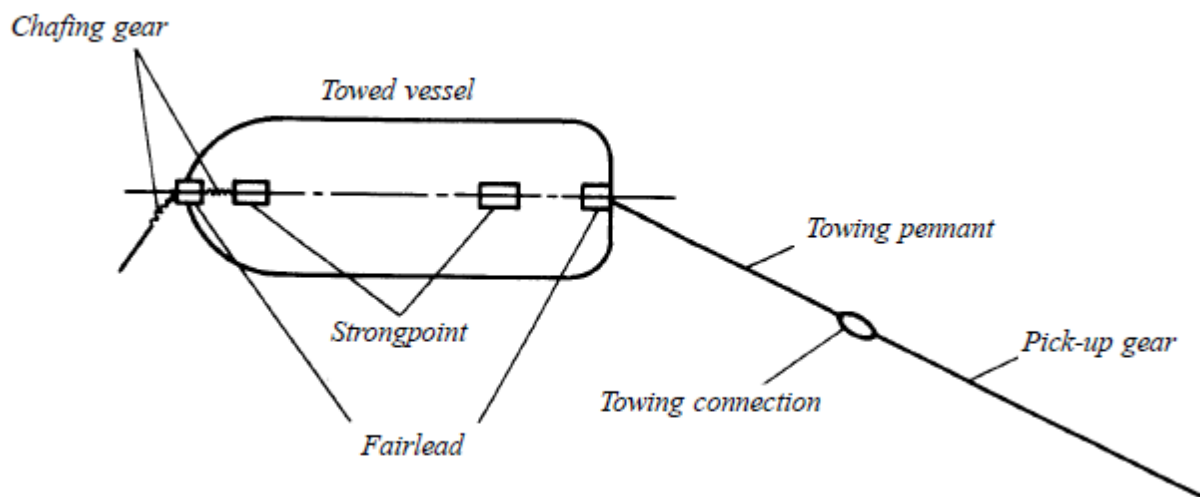

Fig. 5.7.9

5.7.10 All emergency towing arrangements shall be clearly marked to facilitate safe and effective use even in darkness and poor visibility.

5.7.11 Ships shall be provided with a ship-specific emergency towing procedure. Such a procedure shall be carried aboard the ship for use in emergency situations and shall be based on existing arrangements and equipment available on board the ship.

The procedure shall include:

- drawings of fore and aft deck showing possible emergency towing arrangements;
- inventory of equipment on board that can be used for emergency towing;
- means and methods of communication;
- sample procedures to facilitate the preparation for and conducting of emergency towing operations.

¹ refer to IMO MSC.1/Circ.1255/.

6. SIGNAL MASTS

6.1 GENERAL

6.1.1 The requirements given in the present Section refer only to the signal masts, i.e. the masts which are intended for carrying the signal means: navigation lights, day signals, aerials, etc. Where the masts or their parts carry derrick booms or other cargo handling gear in addition to the signal means, such masts or their parts shall comply with the requirements of Cargo Gear Survey, VRS-TWP-ST-005.

The requirements of **6.2 ÷ 6.4**, do not apply to berth-connected ships. The signal masts of berth connected ships shall be designed to carry prescribed signal means.

6.1.2 Arrangement, height and provision of signal means on the signal masts shall comply with the requirements of Convention on the International Regulations for Preventing Collisions at Sea, 1972 (COLREG 72).

6.1.3 If in ships of restricted areas of navigation **R2-S, R2-RS, A-R2-S, A-R2-RS, B-R3-S, B-R3-RS, C-R3-S, C-R3-RS, R3, R3-IN** and **D-R3-S, D-R3-RS** the signal masts are collapsible, special machinery shall be installed for their operation or provision shall be made for appropriate connection with other deck machinery. The drive of the machinery may be hand-operated provided the machinery is self-braking and the load on the handle is not more than 160 N at any moment of jackknifing or hoisting the mast.

6.2 STAYED MASTS

6.2.1 The outside diameter d and the plate thickness t , in mm, at the heel of the masts made of steel having the upper yield stress from 215 up to 255 MPa and stayed by two shrouds on each side of the ship, shall not be less than:

$$d = 22l ; \quad (6.2.1-1)$$

$$t = 0,2l + 3 , \quad (6.2.1-2)$$

where: l – mast length, in m, from the heel to the shroud eye plates.

The diameter of the mast may be gradually decreased upwards to a value of $0,75d$ at the shroud eyeplates, while the thickness of the mast plates is maintained constant throughout the length l .

The mast length from the shroud eye plates to the top shall not exceed $1/3$ of l .

The mast shall be stayed by the shrouds as follows:

.1 horizontal distance a , in m, from the deck (or bulwark) stay eye plate to the transverse plane through the mast stay eye plate shall not be less than

$$a = 0,15h , \quad (6.2.1.1)$$

where: h – vertical distance, in m, from the mast stay eye plate to the deck (or bulwark) stay eye plate;

.2 horizontal distance b , in m, from the deck (or bulwark) stay eye plate to the longitudinal plane through the mast stay eyeplate shall not be less than

$$b = 0,30h ; \quad (6.2.1.2)$$

.3 the value a shall not exceed the value b .

6.2.2 Breaking strength F of the ropes, in kN, used for the mast shrouds as specified in **6.2.1** shall not be less than

$$F = 0,49(l^2 + 10l + 25) . \quad (6.2.2)$$

In other respects, the ropes for shroud shall comply with the requirements of **3.15**, Part XIII "Materials".

The loose gear of shrouds (shackles, turnbuckles, etc.) shall be such that their safe working load is not less than 0,25 times the breaking strength of the ropes referred to above.

6.2.3 Where:

the mast is made of high tensile steel, light alloys, fiber-reinforced plastics or wood (the wood shall be of the 1st grade);

the mast is stayed in a way other than that specified in **6.2.1**;

in addition to a yard arm, lights and day signals, the mast is fitted with other equipment having considerable weight, such as radar reflectors with platforms for their servicing, "crow's nests", etc., proceed as specified in **6.4**.

6.2.4 The wires of shrouds shall have a zinc coating according to recognized standards.

6.3 UNSTAYED MASTS

6.3.1 The outside diameter d and the plate thickness t , in mm, at the heel of masts made of steel having the upper yield stress from 215 to 255 MPa shall not be less than

$$d = 3l^2(0,674l+a+13) \times \left(1 + \sqrt{1 + \frac{51,5 \cdot 10^4}{l^2(0,674l+a+13)^2}}\right) \cdot 10^{-2}; \quad (6.3.1-1)$$

$$t = \frac{1}{70} d, \quad (6.3.1-2)$$

where: l – length of the mast from heel to top, in m;

a – elevation of the mast heel above centre of gravity of the ship, in m.

The outside diameter of the mast may be gradually decreased upwards to a value $0,5d$ at the distance $0,75l$ from the heel.

In no case the thickness of the mast plate shall be less than 4 mm.

The mast heel shall be rigidly fixed in all directions.

6.3.2 Where:

the mast is made of high tensile steel, light alloys, fiber-reinforced plastics or wood (the wood shall be of the 1st grade);

in addition to a yard arm, lights and day signals, the mast is fitted with other equipment having considerable weight, such as radar reflectors with platforms for their servicing, "crow's nests", etc. proceed as provided in **6.4**.

6.4 MASTS OF SPECIAL CONSTRUCTION

6.4.1 In the cases specified in **6.2.3** and **6.3.2** as well as where bipod, tripod and other similar masts are installed, detailed strength calculations of these masts shall be carried out. These calculations shall be submitted to the Register for review.

6.4.2 The calculations shall be performed on the assumption that each part of the mast is affected by a horizontal force F_i , in kN

$$F_i = \left[m_i \frac{4\pi^2}{T^2} (\theta z_i + r \sin \theta) + m_i g \sin \theta + p A_i \cos \theta \right] \cdot 10^{-3}, \quad (6.4.2)$$

where: m_i – mass of each part, in kg;

z_i – elevation of the centre of gravity of each part above that of the ship, in m;

A_i – side-projected area of each part, in m²;

T – rolling or pitching period, in s;

θ – amplitude of roll or pitch, in rad.;

r – wave half-height, in m;

$g = 9,81$ – acceleration due to gravity, in m/s²;

p – 1960 Pa - specific wind pressure.

The calculations shall be carried out both for rolling and pitching of the ship, r being taken as equal to $L/40$ where L is the ship's length, in m, and y , in rad., as corresponding to an angle of 40° at roll and of 5° at pitch.

6.4.3 Under the loads specified in **6.4.2** of this Part, the stresses in the parts of the mast shall not exceed 0,7 times the upper yield stress of their material where they are made of metal, and 12 MPa where they are made of wood. The safety factor of the standing ropes under the same loads shall not be less than 3.

For fiber-reinforced plastic masts under the loads specified in **6.4.2** of this Part the stresses in the parts of the mast shall not exceed the allowable stress value indicated in Table 3 of Appendix 3, Part XVI "Structure and Strength of Fiber-Reinforced Plastic Ships" for the case of short-time action of the load for the relevant type of deformation.

7. OPENINGS IN HULL, SUPERSTRUCTURES AND DECKHOUSES AND THEIR CLOSING APPLIANCES

7.1 GENERAL

7.1.1 The requirements of this Section apply to ships of unrestricted service **A** as well as to ships of restricted areas of navigation **R1, R2, A-R1, A-R2, R2-S, R2-RS, A-R2-S, A-R2-RS, B-R3-S, B-R3-RS, C-R3-S, C-R3-RS**, engaged on international voyages.

The requirements for ships of restricted areas of navigation **R1, R2, A-R1, A-R2, R2-RS, R2-S, R2-RS, A-R2-S, A-R2-RS, B-R3-S, B-R3-RS, C-R3-S, C-R3-RS**, not engaged on international voyages, as well as for ships of restricted areas of navigation **R3, R3-IN** and **D-R3-S, D-R3-RS** may be relaxed; the extent of relaxation shall be confirmed by technical background.

7.1.2 The requirements of this Section apply to ships to which a minimum freeboard is assigned. Deviation from these requirements may be permitted for the ships to which a greater than minimum freeboard is assigned on condition that the Register is satisfied with safety conditions provided.

7.1.3 The arrangement of openings and their closing appliances in the hull, superstructures and deckhouses shall also comply with the requirements of Part VI "Fire Protection" and Part XI "Electrical Equipment".

7.1.4 As far as deck openings are concerned, the following two positions are distinguished in this Section.

7.1.4.1 Position 1: Upon exposed freeboard and raised quarter decks, and upon exposed superstructure decks situated forward of a point located a quarter of the ship's length from the forward perpendicular.

7.1.4.2 Position 2: Upon exposed superstructure decks situated abaft a quarter of the ship's length from the forward perpendicular and located at least at one standard height of superstructure above the freeboard deck.

Upon exposed superstructure decks situated forward of a point located a quarter of the ship's length from the forward perpendicular and located at least two standard heights of superstructure above the freeboard deck.

7.1.5 The height of coamings specified in this Section is measured from the upper surface of the steel deck plating or from the upper surface of the wood or other sheathing, if fitted.

7.1.6 In supply vessels the access to the spaces situated below the open cargo deck shall preferably be provided from the location inside the enclosed superstructure or deckhouse or from the location above the superstructure deck or deckhouse top.

The arrangement of companion or other hatches on the open cargo deck leading to the spaces below this deck may be allowed when adequate degree of protection of these hatches from possible damage during cargo handling operations is provided.

7.1.7 The requirements of the present Section for floating docks apply to openings and their closing appliances arranged above the margin line at docking.

7.1.8 In docklift ships, regardless of the provisions of **7.4 ÷ 7.7**, it is not permitted to arrange openings for doors, companion hatches, skylights, ventilating trunks and other hatches in sides and boundary bulkheads of holds if their lower edges are below the margin line at docking, with the exception of the openings to the watertight spaces of a restricted volume not communicating with other spaces below the level of the margin line at docking.

7.1.9 Doors and hatchways in sides and boundary bulkheads of holds in docklift ships, if their sills are above the margin line at docking by less than 600 mm or 0,05 times the distance between the openings and the

centreline whichever is the greater, shall be provided with the light signalling system comprising the indicators installed in the control post of the ship's docking operations. The light indicators shall clearly show the position of the door or hatch cover (secured or open).

7.1.10 The light signals specified in **7.1.9** need not be provided for doors and hatchways to the watertight spaces of a restricted volume not communicating with other spaces below the level which is by 600 mm or 0,05 times the distance between the opening and the centreline, whichever is the greater, above the margin line at docking.

7.1.11 In cargo ships covered by the requirements of Part V "Subdivision", the openings for access, piping, ventilation, electric cables, etc. in watertight internal bulkheads and decks shall be provided with watertight doors or hatch covers normally closed when at sea which, in their turn, shall be provided with indication means, positioned in their close proximity and on the bridge, to indicate whether such doors or hatch covers are open or closed.

On each side of such a door or hatch cover there shall be an inscription to the effect the closure shall not be left open.

7.1.12 In ships mentioned under **7.1.11**, all external openings which do not, by their location, conform to the requirements of **3.4.4**, Part V "Subdivision" shall be fitted with strong enough watertight closures for which, except cargo hatch covers, provision shall be made for bridge indication.

The watertight closures of shell openings located below the bulkhead deck shall be permanently closed at sea shall be fitted with devices preventing their uncontrolled opening. Plates shall be attached to such closures with inscriptions to the effect the openings shall be permanently closed at sea.

7.1.13 In dry cargo ships not covered by the requirements of **7.1.11** and **7.1.12** all the doors of sliding or hinged type in watertight bulkheads shall be fitted up with indication means positioned on the bridge to indicate whether such doors are open or closed. Similar indicators shall be provided for shell doors and other closing appliances which, if left open or not properly secured, can lead to solid flooding of the ship.

7.1.14 The requirements of Section 7 do not apply to berth-connected ships. For these ships, the following provisions apply:

the coaming height of openings of companion hatches, skylights, ventilation trunks and ventilation heads shall not be less than 100 mm;

weathertight hatch covers shall be provided;

the external doors of superstructures shall be watertight, but where the lower edge of an external door is not less than 600 mm away from the waterline corresponding to the maximum draught, such doors may be weathertight;

the lower edge of a side light shall not be less than 150 mm away from the waterline corresponding to the maximum draught;

on the freeboard deck, the superstructure and deckhouse windows shall be watertight.

7.2 SIDE SCUTTLES

7.2.1 Position of side scuttles.

7.2.1.1 The number of side scuttles in the shell plating below the freeboard deck shall be reduced to a minimum compatible with the design and proper working of the ship.

Fishing vessels mooring alongside each other or other ships at sea shall not have side scuttles under freeboard deck in the mooring zone, wherever possible. If in this zone side scuttles are fitted in the shell plating, they shall be so positioned that the possibility of their damage during mooring operations is excluded.

No side scuttles are permitted within the boundaries of the ice belt of the shell plating specified in Part II "Hull" in icebreakers and ice class ships.

7.2.1.2 No side scuttle shall be fitted in a position so that its sill is below a line drawn parallel to the freeboard deck at side and having its lowest point located 0,025 of the ship's breadth B or 500 mm, whichever is the greater, above the summer load waterline or above the summer timber load waterline where timber load lines are assigned to the ship.

In ships of restricted areas of navigation **R2**, **R2-S**, **R2-RS**, **R3-S**, **R3-RS**, **R3-IN** and **R3** (except for passenger ships of length 24 m and over), not engaged on international voyages the specified distance 500 mm may be disregarded.

If the length of the ship is less than 24 m, the specified distance may be reduced to 300 mm for ships of restricted areas of navigation **R2**, **R2-S**, **R2-RS**, **R3-S**, **R3-RS** (except for passenger ships) and to 150 mm for ships of restricted areas of navigation **R3** and **R3-IN**.

7.2.1.3 Side scuttles in the shell plating, below the bulkhead deck of passenger ships and the freeboard deck of cargo ships in front bulkheads of enclosed superstructures and deckhouses of the first tier and also in front bulkheads of enclosed superstructures and deckhouses of the second tier within $0,25L$ from the forward perpendicular shall be of a heavy type and fitted with efficient deadlights hinged inside (refer also to **2.4.5**, Part VI "Fire Protection").

In tugs of restricted areas of navigation **R2, R2-S, R2-RS, R3-S, R3, R3-IN** the side scuttles fitted below the bulkhead deck shall be not only of heavy but also of non-opening type.

In ships of restricted areas of navigation **R2, R2-S, R2-RS, R3-S, R3-RS** having the length below 24 m and in ships of restricted areas of navigation **R3** and **R3-IN** it is allowed to fit side scuttles of normal type instead of those of heavy type.

In passenger ships of areas of navigation **A, A-R1, A-R2, A-R2-S, A-R2-RS, B-R3-S, B-R3-RS, C-R3-S, C-R3-RS, D-R3-S, D-R3-RS** all side scuttles, the lower edges of which are below the bulkhead deck, shall be of non-opening type.

7.2.1.4 In ships to which the requirements of Part V "Subdivision" apply the side scuttles outside a floodable compartment or a specified group of compartments, fitted in a position so that their sills are by less than 0,3 m or $\left(0,1 + \frac{L-10}{150}\right)$ m, whichever is less, above the corresponding damage waterline and the side scuttles

in the floating cranes the sills of which are by less than 0,3 m above the waterline corresponding to the actual maximum statical heel in case the hook is under load, shall be not only of heavy but also of non-opening type.

In ships of restricted areas of navigation **R2, R2-S, R2-RS, R3-S, R3-RS** having the length below 24 m and in ships of restricted areas of navigation **R3, R3-IN** and **D-R3-S, D-R3-RS** it is allowed to fit side scuttles of normal non-opening type instead of those of heavy non-opening type.

7.2.1.5 Side scuttles in enclosed superstructures and deckhouses of the first tier, except those in their front bulkheads, and also side scuttles in enclosed superstructures and deckhouses of the second tier within $0,25$ of the ship's length L from the forward perpendicular, except those in their front bulkheads, may be of normal type.

In ships of restricted areas of navigation **R2, R2-S, R2-RS, R3-S, R3-RS, B-R3-S, B-R3-RS, C-R3-S** and **C-R3-RS** having the length below 24 m and in ships of restricted areas of navigation **R3, R3-IN** and **D-R3-S, D-R3-RS** it is allowed to fit side scuttles of light type instead of those of normal type.

Side scuttles shall be fitted with efficient deadlights hinged inside.

7.2.1.6 Side scuttles in enclosed superstructures and deckhouses of the second tier, except those fitted in a position within $0,25$ of the ship's length from the forward perpendicular shall be as required in **7.2.1.5**, provided these side scuttles give direct access to an open stairway leading to spaces situated below.

In cabins and similar spaces of enclosed superstructures and deckhouses of the second tier it is allowed that instead of side scuttles specified in **7.2.1.5**, the side scuttles or windows could be fitted without deadlights.

7.2.1.7 On no account shall the side scuttles be fitted in the outer wall sides of the floating docks and in the sides of the docklift ships so that their sills are below the margin line at docking. In the inner wall sides of the floating docks and in the boundary bulkheads of the docklift ships installation of the side scuttles is not permitted.

7.2.1.8 In the outer wall sides of the floating docks and in the sides of the docklift ships the side scuttles, the sills of which are above the margin line at docking by less than 300 mm or $0,025$ times the ship's breadth, whichever is the greater, shall be of heavy type, fitted with hinged inside deadlights, and of non-opening type.

7.2.1.9 In the outer wall sides of the floating docks the side scuttles, the sills of which are above the margin line at docking by 300 mm or more, shall be of normal type and fitted with hinged inside deadlights.

7.2.1.10 Ships with distinguishing marks **FF1** and **FF2** in the class notation shall be fitted with side scuttles having deadlights permanently attached to their primary structure, wheelhouse windows shall be fitted with detachable screens, except side scuttles and windows in the wheelhouse, and search and rescue operation control station.

7.2.1.11 On the standby vessel, the front and side scuttles in the wheelhouse shall be equipped with effective protective shields installed on either side of the bulkhead.

The strength of such shields must be equivalent to the strength of the bulkhead.

The shields must provide visibility from the navigation bridge, they can be removable and must be stored in an accessible place for quick and easy installation.

7.2.1.12 All side scuttles below the bulkhead deck on passenger ships and freeboard deck on cargo ships shall be fitted with detachable screens permanently attached to their primary structure, which can be easily and securely sealed and watertight, except, that the side scuttles located $1/8$ of the ship's length from the bow

perpendicular and above the line parallel to the bulkhead deck and which has its lowest point at a distance of 3.7 m plus 2.5% of the ship's breadth above the draft at the highest subdivision waterline, may be fitted with detachable screens in the passenger spaces, unless the Load Line Rules require that screens shall be permanently attached in fixed positions. Such detachable screens shall be kept close to the side scuttles for which they are intended.

7.2.1.13 The side scuttles below the bulkhead deck on passenger ships and freeboard deck on cargo ships shall not be installed in spaces intended solely for the carriage of cargo.

7.2.1.14 Side scuttles and windows, together with their glass and shields, if installed, shall be of a solid structure approved by the Register. Non-metallic frames are not allowed.

Side scuttles means round or oval openings with clear area of not more than 0.16 m². Round or oval openings with clear area of more than 0.16 m² are equated to windows.

Windows are usually rectangular openings with rounded corners, commensurate with the dimensions of windows, as well as round or oval openings with clear area of more than 0,16m².

7.2.2 Construction and attachment of side scuttles and windows.

7.2.2.1 These Rules distinguish three types of side scuttle construction:

.1 heavy type with the glass thickness of not less than 10 mm for inner diameter of 200 mm and below, not less than 15 mm for inner diameter from 300 mm to 350 mm and not less than 19 mm for inner diameter of 400 mm.

The inner diameter shall not exceed 400 mm. For intermediate inner diameters (from 200 mm to 300 mm and from 350 mm to 400 mm) the glass thickness shall be determined by linear interpolation.

In addition, heavy side scuttles if they are of the opening type shall have a nut (instead of one of the ear-nuts securing their frame) being screwed off with the aid of a special wrench;

.2 normal type with the glass thickness of not less than 8 mm for inner diameter of 250 mm and below, and not less than 12 mm for inner diameter of 350 mm and over, however, the inner diameter shall not exceed 400 mm. For intermediate inner diameters the thickness of the glass shall be determined by linear interpolation;

.3 light type with the glass thickness of not less than 6 mm for inner diameter of 250 mm and below and not less than 10 mm for inner diameter of 400 mm and over, however, the inner diameter shall not exceed 450 mm. For intermediate inner diameters the thickness of the glass shall be determined by linear interpolation.

7.2.2.2 Normal and heavy side scuttles may be of non-opening type, i.e. with the glass fixed in the main frame, or of opening type, i.e. with the glass fixed in the glazing bead efficiently hinged on the main frame.

Exception shall be made for the cases specified in **7.2.1.3**, **7.2.1.4** and **7.2.1.8**, where the side scuttles shall be of non-opening type only.

The glasses of side scuttles shall be reliably and weathertight secured by means of a metal ring provided with screws or by other equivalent device and a gasket.

7.2.2.3 The main frame, glazing bead and deadlight of side scuttles shall have sufficient strength.

The glazing bead and deadlight shall be fitted with gaskets and shall be capable of being effectively closed and secured weathertight by means of ear-nuts or nuts being screwed off with the aid of a special wrench.

7.2.2.4 The main frame, glazing bead, deadlight and ring for securing the glass shall be manufactured from steel, brass or other material approved by the Register.

The ear-nuts and nuts being screwed off by a special wrench shall be made of corrosion-resistant material.

Glass used for the side scuttles shall be hardened.

7.2.2.5 In fiber-reinforced plastic ships side scuttles shall be attached to the outside plating and to the bulkheads of superstructures and deckhouses in accordance with the requirements of **1.7.4**, "Structure and Strength of Fiber-Reinforced Plastic Ships".

7.2.2.6 The construction of the windows shall comply with the requirements of **7.2.2.2** ÷ **7.2.2.4**, except for the requirements for the deadlights.

The thickness of the window glass t , in mm, shall be not less than determined by the formula

$$t = 0,32kb\sqrt{p}, \quad (7.2.2.6-1)$$

where: b – lesser clear size of the window, in m;

p – pressure head, in kPa, calculated according to 2.12.3, Part II "Hull"; distance z_1 being taken up to the middle of the window height;

k – factor determined by the formula

$$k = 13,42 - 5,125 (b/a)^2;$$

where: a – greater clear size of the window, in m.

7.3 FLUSH DECK SCUTTLES

7.3.1 Flush deck scuttles in positions 1 and 2 shall be provided with deadlights hinged or attached by other method (for example, by means of a chain) and capable of being easily and efficiently closed and secured.

7.3.2 The largest of clear dimensions of the flush deck scuttles shall not be over 200 mm, with the glass being at least 15 mm thick. The flush deck scuttles shall be attached to the metal deck plating by means of frames.

7.3.3 When secured, the deadlights of the flush deck scuttles shall be weathertight. The tightness shall be ensured by a rubber or other suitable gasket. For the same purpose, along their contour the glasses of the flush deck scuttles shall be provided with a gasket made of rubber or other suitable material.

7.3.4 The strength and materials of the flush deck scuttles parts are governed by applicable requirements specified in 7.2.2.3 and 7.2.2.4.

As regards attachment of flush deck scuttles in fiberreinforced plastic ships, refer to 7.2.2.5.

7.4 OPENINGS IN SHELL PLATING AND THEIR CLOSING APPLIANCES

7.4.1 General.

7.4.1.1 This Chapter contains requirements for the arrangement of bow, side and stern doors in the shell plating, strength of structural elements of the doors, securing, locking and supporting devices.

7.4.1.2 The number of doors shall be reduced to a minimum consistent with the structure and normal operational conditions of the ship.

7.4.1.3 When closed and secured, doors in the shell plating shall be weathertight. Weathertightness shall be ensured with a rubber or other suitable packing.

7.4.1.4 The plating thickness of the doors made of steel, irrespective of the fulfilment of the requirements given in 7.4.1.10, shall be not less than the thicknesses referred to in 2.2.4.8 and 2.12.4.1 of Part II "Hull" for the appropriate position of the door; the minimum plating thickness of the doors made of other materials may be allowed provided it is confirmed by calculations and tests that they have a strength at least equivalent to that of the doors made of steel.

7.4.1.5 Doors with a clear area of 12 m² and more shall be secured by means of a power system or by a hand gear used for securing the door from a readily accessible position. Stern, bow and side doors of large dimensions, when manual devices would not be readily accessible, shall be normally secured by means of power systems. Alternative means of securing shall also be provided for emergency use in case of failure of the power systems.

7.4.1.6 When power-operated securing devices or devices with a hand gear are used, it is necessary to ensure that the doors shall remain tight in the secured position and shall remain secured in case of failure of any part of the power system or hand gear of the securing device.

Hydraulically operated securing devices shall be manually or mechanically lockable in the secured position.

7.4.1.7 When power-operated securing devices or devices with a hand gear are used, provision shall be made for the indicators which clearly show whether the door is totally secured or not.

These indicators shall be fitted in a position from which the securing operation is performed, and in case of the power-operated securing device, also on the navigation bridge.

7.4.1.8 If, due to the ship's purpose, it is specially provided to open and close the doors not only in ports but also at sea, arrangements approved by the Register shall be made (with regard to the operational conditions) to ensure closure and complete securing of the open door, even in case of failure of the door gear and securing device gear, or other arrangements approved by the Register shall be made to prevent penetration of water into the ship spaces when the door is open.

Provision shall be made for devices ensuring proper locking of the door in the open position.

The drives of such doors shall comply with the requirements of Part IX "Machinery" and Part XI "Electrical Equipment".

7.4.1.9 There shall be a readily seen notice plate near each door, indicating that the door shall be closed and secured before the ship leaves the port; for doors referred to in 7.4.1.8 provision shall be also made for a notice plate indicating that at sea only the master is allowed to open the door.

7.4.1.10 When doors are under the action of the design loads determined in accordance with 7.4.2 and 7.4.3, except 7.4.2.5, stresses, in MPa, in the primary members of the doors as well as of securing, locking and supporting devices shall not exceed the following values:

normal stress

$$\sigma = 120/k, \quad (7.4.1.10-1)$$

shear stress

$$\tau = 80/k, \quad (7.4.1.10-2)$$

equivalent stress

$$\sigma_{3B} = \sqrt{\sigma^2 + 3\tau^2} = 150/k, \quad (7.4.1.10-3)$$

where: $k = 1,0$ – for steel with upper yield stress of the material $R_{eH} = 235$ MPa;

$k = 0,78$ – for steel with $R_{eH} = 315$ MPa;

$k = 0,72$ – for steel with $R_{eH} = 335$ MPa.

7.4.2 Bow doors.

7.4.2.1 Bow doors shall be situated above the freeboard deck.

7.4.2.2 Where the bow door leads to a complete or long forward enclosed superstructure a weathertight inner door shall be installed as part of the collision bulkhead above the freeboard deck of the ship.

Bow and inner doors shall be so arranged as to preclude the possibility of the bow door causing structural damage to the inner door or to the collision bulkhead in case of damage to or detachment of the bow door.

7.4.2.3 The design external pressure P_e , кПа, in kPa, for the scantlings of primary members, securing, locking and supporting devices of the bow doors is determined by the following formula:

$$P_e = C_H(0,6+0,41\text{tg}\alpha)(0,4v\sin\beta+0,6\sqrt{L})^2, \quad (7.4.2.3)$$

where: C_H – is a coefficient equal to:

0,0125L – for ships less than 80 m in length;

1,0 – for ships 80 m and more in length;

v – contractual ship's forward speed, in knots;

α and β – angles to be obtained from Fig. 7.4.2.3.

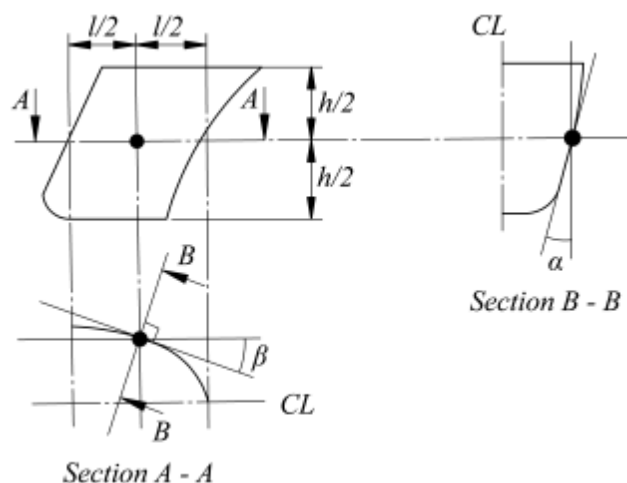

Fig. 7.4.2.3

The design external pressure may be reduced by 20 % for ships of restricted areas of navigation **R2-S**, **R2-RS**, **R3-S**, **R3-RS**, **B-R3-S**, **B-R3-RS**, **C-R3-S** and by 40 % for ships of restricted areas of navigation **R3**, **R3-IN** and **D-R3-S**, **D-R3-RS**.

In any case, the design external pressure P_e shall not be taken less than the values determined according to 1.3.2.2 or 2.8.3.3, Part II "Hull", whichever is the greater.

7.4.2.4 The design internal pressure P_i , in kPa, for scantlings of primary members, securing, locking and supporting devices of inner doors shall be determined by the formula

$$P_i = 10z, \quad (7.4.2.4)$$

where: z – vertical distance from the centre of gravity of the door area to the deck above, in m.

In all cases, the value of the design internal pressure P_i shall not be less than 25 kPa.

7.4.2.5 The scantlings of primary members of visor doors shall be chosen in accordance with the requirements of 2.8.5.1, Part II "Hull".

7.4.2.6 Securing and locking devices of bow doors shall be designed to withstand the forces F_e or F_i , in kN, to be determined by the following formulae:

for the doors opening inwards

$$F_e = AP_e + p_p l_p, \quad (7.4.2.6-1)$$

for the doors opening outwards

$$F_i = AP_i + 10Q + p_p l_p, \quad (7.4.2.6-2)$$

where: A – clear area of the door, in m²;

for P_e – refer to 7.4.2.3;

for P_i – refer to 7.4.2.4;

p_p – pressure of the packing when it is compressed for the maximum depth possible, in kN/m, is assumed in calculations equal to at least 5 kN/m;

l_p – length of the packing, in m;

Q – mass of the door, in t.

7.4.2.7 Securing and locking devices, as well as supports of the visor doors shall be designed to withstand forces F_{xf} , F_{xa} , F_y and F_z , in kN.

The forces acting in the longitudinal direction shall be determined by the following formulae:

bow

$$F_{xf} = \frac{10Qc + P_{xe}a - P_e b}{d}; \quad (7.4.2.7-1)$$

stern

$$F_{xa} = \frac{10Qc - P_{xi}a}{d}. \quad (7.4.2.7-2)$$

The force acting in the transverse direction shall be determined by the formula

$$F_y = P_e A_y. \quad (7.4.2.7-3)$$

The force acting in the vertical direction shall be determined by the formula

$$F_z = P_z - 10Q \quad (7.4.2.7-4)$$

or

$$F_z = 10(V - Q), \quad (7.4.2.7-5)$$

whichever is the greater,

where for Q – refer to **7.4.2.6**;

for P_e – refer to **7.4.2.3**;

$$P_{xe} = P_e A_x \text{ in kN}; \quad (7.4.2.7-6)$$

A_x – area of the transverse vertical projection of the door (refer to Fig. 7.4.2.7), in m²;

$$P_z = P_e A_z \text{ in kN}; \quad (7.4.2.7-7)$$

A_z – area of horizontal projection of the door (refer to Fig. 7.4.2.7), in m²;

$$P_{xi} = P_i A_x \text{ in kN}; \quad (7.4.2.7-8)$$

for P_i – refer to **7.4.2.4**;

A_y – area of the longitudinal vertical projection of the door (refer to Fig. 7.4.2.7), in m²;

a – vertical distance, in m, from visor pivot to the centroid of the transverse vertical projected area of the visor door (refer to Fig. 7.4.2.7);

b – vertical distance, in m, from visor pivot to the centroid of the horizontal projected area of the visor door (refer to Fig. 7.4.2.7);

c – horizontal distance, in m, from visor pivot to the centre of gravity of the visor mass (refer to Fig. 7.4.2.7);

d – vertical distance, in m, from visor pivot to the bottom of the door (refer to Fig. 7.4.2.7);

V – inner volume of the door, in m³.

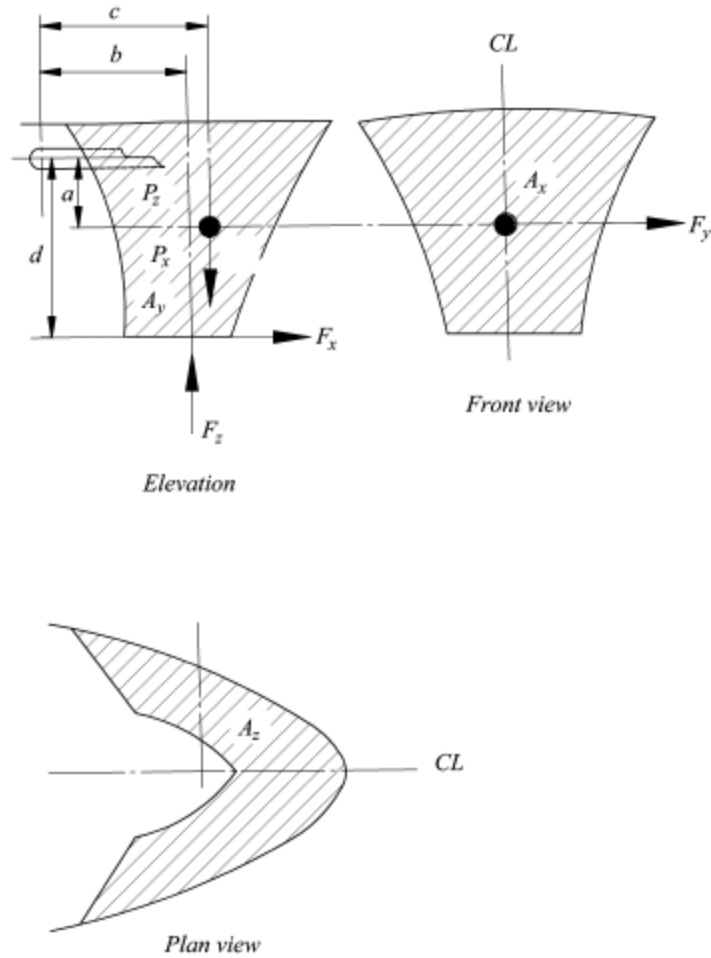

Fig. 7.4.2.7

7.4.2.8 For side-opening doors, thrust bearing shall be provided in way of girder ends at the closing of two leaves to prevent one leaf shifting towards the other one under effect of unsymmetrical pressure (refer to Fig. 7.4.2.8). Each part of the thrust bearing shall be kept secured on the other part by means of securing devices.

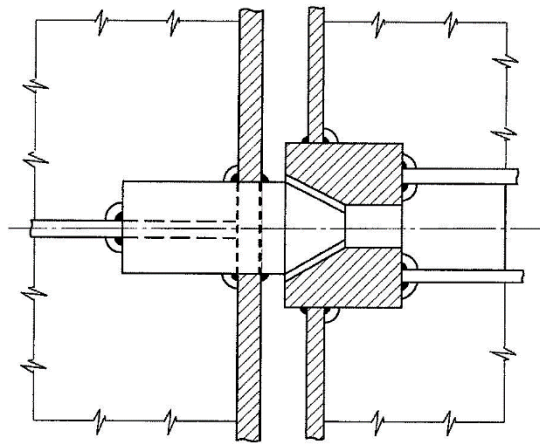

Fig. 7.4.2.8

7.4.2.9 Lifting arms of the visor doors and thrust bearing shall be designed to withstand static and dynamic loads arising when the door is opened and closed with due regard to the minimum wind pressure 1,5 kN/m².

7.4.3 Side and stern doors.

7.4.3.1 The lower edge of the door openings shall not be lower than the line which is parallel to the freeboard deck and has its lowest point at the uppermost cargo waterline.

The lower edge of side doors of the ships which are not passenger ships, may be lower than that specified above provided it is proved by the designer that safety of the ship will not be thus impaired.

In such cases, provision shall be made for:

the second (inner) doors, strength and tightness of which is equivalent to those of the outer doors;

a device enabling to determine water presence in the space between the doors;

water drainage from this space to bilges or drain wells, controlled by a readily accessible valve or other arrangements approved by the Register.

7.4.3.2 The doors shall open outwards so that forces acting under the effect of the sea press the door against the supporting contour of the sill.

Installation of the doors opening inside may be allowed provided it is proved by the designer that safety of the ship will not be thus impaired.

7.4.3.3 The number of securing devices on each edge of the door shall be not less than two; a securing device shall be provided in the vicinity of each door corner. The distance between securing devices shall not exceed 2,5 m.

7.4.3.4 The design external pressure P , in kPa, for structural members of doors shall be determined in accordance with the requirements of **1.3.2**, Part II "Hull". In any case, the value of P shall not be taken less than 25 kPa.

7.4.3.5 Securing and locking devices shall be designed to withstand the forces F_1 or F_2 , in kN, determined by the formulae:

for doors opening inwards

$$F_1 = AP + p_p l_p ; \quad (7.4.3.5-1)$$

for doors opening outwards

$$F_2 = F_c + 10Q + p_p l_p , \quad (7.4.3.5-2)$$

where for A , p_p and l_p – refer to **7.4.2.6**;

for P – refer to **7.4.3.4**;

F_c – an accidental force due to loose cargo, to be uniformly distributed over the area A and to be taken not less than 300 kN or $5A$, in kN, whichever is the greater.

For small doors, such as bunker doors or pilot doors, the value of F_c may be reduced based on appropriate technical background. In case the second (inner) door is installed, which is capable to protect the external door from accidental forces due to loose cargoes, $F_c = 0$;

for Q – refer to **7.4.2.6**.

Supporting structures of doors shall be designed to withstand forces F_3 and F_4 , kH, in kN, determined by the formulae:

for doors opening inwards

$$F_3 = AP ; \quad (7.4.3.5-3)$$

for doors opening outwards

$$F_4 = F_c + 10Q . \quad (7.4.3.5-4)$$

7.5 SUPERSTRUCTURES AND DECKHOUSES

7.5.1 Construction, openings and closing appliances.

7.5.1.1 Openings in the freeboard deck other than those defined in 7.3, 7.6 ÷ 7.11 and 7.13, shall be protected by the enclosed superstructure or enclosed deckhouse. The similar openings in the deck of enclosed superstructure or enclosed deckhouse shall be protected by enclosed deckhouse of the second tier.

7.5.1.2 Superstructures and deckhouses are considered enclosed if:

their construction complies with the requirements of 2.12, Part II "Hull";

all access openings comply with the requirements of 7.5.2 and 7.7;

all other openings in their outside contour comply with requirements of 7.2 ÷ 7.4 and 7.7 ÷ 7.10.

7.5.2 Doors in enclosed superstructures and enclosed deckhouses..

7.5.2.1 All access openings in the end bulkheads of enclosed superstructures and outside bulkheads of enclosed deckhouses shall be fitted with doors (refer to 2.4.4, Part VI "Fire Protection").

7.5.2.2 The height of the sills to access openings specified in 7.5.2.1 shall be at least 380 mm. However, the bridge or poop shall not be regarded as enclosed unless access is provided for the crew to machinery and other working spaces inside these superstructures from any place in the uppermost continuous open deck or above it by alternative means which are available at all times when bulkhead openings are closed; the height of the sills of the openings in the bulkheads of such bridge or poop shall be at least 600 mm in position 1 and at least 380 mm in position 2.

In ships of restricted areas of navigation **R3 i R3-IN** having the length of 24 m and over (except for passenger ships) the specified height of the sills to access openings may be reduced from 600 mm down to 450 mm and from 380 mm down to 230 mm, respectively.

In ships of restricted areas of navigation **R2, R2-RS, R3-S, R3-RS, B-R3-S, B-R3-RS, C-R3-S, R3, R3-IN** and **D-R3-S, D-R3-RS** having the length below 24 m the height of the above sills may be reduced to 230 mm for all open decks.

7.5.2.3 The doors shall be so designed as to withstand the pressure head p calculated according to 2.12.3, Part II "Hull", the distance z_l being taken up to the middle of the door height. Under the pressure head p the stresses in the door elements shall not exceed 0,8 times the upper yield stress of the material.

Whatever the stresses, the thickness of the steel door plate shall be not less than that specified in 2.12.4.4, Part II "Hull". For steel doors manufactured by stamping the minimum thickness of the door plate may be reduced by 1 mm.

The minimum thickness of the door plate made of other materials may be allowed provided it is confirmed by calculations and tests that they have a strength at least equivalent to that of the doors made of steel.

7.5.2.4 The doors shall be permanently and strongly attached to the bulkhead and fitted with clamping devices or other equivalent means for expeditiously opening, closing and securing them weathertight; such devices shall be so arranged that they can be operated from both sides of the bulkhead.

The doors shall open outwards, opening of doors inside the superstructure or deckhouse space may be allowed when security against the impact of the sea is provided.

7.5.2.5 The doors shall be weathertight when secured. The tightness shall be ensured by a rubber or other suitable gasket.

7.5.2.6 The doors shall be made of steel or other material approved by the Register.

7.5.2.7 In fiber-reinforced plastic ships the doors shall be attached to the bulkheads of superstructures and deckhouses in the same manner as the side scuttles, in accordance with the requirements of 7.2.2.5.

7.5.2.8 In floating docks the height of the sills to access openings in superstructures and deckhouses of the top deck shall be at least 200 mm if access is provided from these superstructures and deckhouses into the spaces situated below.

7.5.3 Watertightness of passenger ships of restricted areas of navigation A-R2, A-R2-S, A-R2-RS, B-R3-S, B-R3-RS, C-R3-S, C-R3-RS, D-R3-S, D-R3-RS above the immersion limit line.

7.5.3.1 All reasonable and practicable means are to be taken to restrict the penetration and spread of water above the bulkhead deck. Such means may be hulf bulkheads or web frames.

If watertight hulf bulkheads or web frames are installed on the bulkhead deck above watertight subdivision bulkheads or in the immediate vicinity of such bulkheads, they are to have a watertight connection with the outer skin and the bulkhead deck in order to limit the spread of water on the deck when the ship has a roll in a damaged condition. If the watertight hulf bulkhead does not coincide with the bulkhead below, then the bulkhead deck in the area between them is to be watertight.

7.5.3.2 Storm ports and scuppers shall be fitted where necessary to provide rapid removal of water from the weather deck in all weather conditions.

7.6 ENGINE AND BOILER CASINGS

7.6.1 Engine and boiler space openings in positions 1 and 2 shall be efficiently enclosed by casings of ample strength raised above decks to the extent, which is reasonable and practicable, and being in their turn decked or terminated in skylights. The construction of the casings shall meet the requirements of **2.13**, Part II "Hull", and in case of fiber-reinforced plastic ships, the requirements of Part XVI "Structure and Strength of Fiber-Reinforced Plastic Ships".

7.6.2 Casings shall be made weathertight.

7.6.3 Casings shall be made of steel or other materials approved by the Register (refer also to **2.1.1.2**, Part VI "Fire Protection").

7.6.4 The access openings in the casings shall be fitted with permanently attached doors complying with the requirements of **7.5.2.3 ÷ 7.5.2.6**. The height of the sills to the access openings shall be at least 600 mm in position 1 and at least 380 mm in position 2.

If the length of the ship is less than 24 m, the specified height of the sills may be reduced down to 300 mm for ships of restricted areas of navigation **R2, R2-RS, R3-S, R3-RS, B-R3-S, B-R3-RS, C-R3-S, R3, R3-IN** and **D-R3-S, D-R3-RS**.

In ships of restricted areas of navigation **R3** and **R3-IN** having the length of 24 m and over (except passenger ships) the specified height of the sills may be reduced from 600 mm down to 450 mm and from 380 mm down to 230 mm, respectively.

7.6.5 In type "A" ships and also in type "B" ships which are permitted to have the tabular freeboard less than that prescribed in Regulation 28 of International Convention on Load Lines, 1966, as modified by the 1988 Protocol relating thereto with further amendments (LL 66/88), the engine and boiler casings shall be protected by enclosed poop or bridge of at least standard height, or by a deckhouse of equal height and equivalent strength.

However, engine and boiler casings may be exposed if there are no openings giving direct access from the freeboard deck to the machinery space. A door complying with requirements of **7.5.2.3 ÷ 7.5.2.6**, may, however, be permitted in the machinery casing provided that it leads to a space or passageway which is as strongly constructed as the casing and is separated from the stairway to the engine and boiler room by a second similar door. The opening for the outside door shall be provided with a sill at least 600 mm in height, and that for the inside door with a sill of at least 230 mm in height.

7.6.6 In supply vessels the doors in the casings giving access to the engine or boiler rooms shall be located, where possible, inside the enclosed superstructure or deckhouse.

The door in the casing for access to the engine or boiler room may be fitted directly on the open cargo deck provided that, in addition to the first outside door, the second inside door is fitted; in this case, the outside and inside doors shall satisfy the requirements of **7.5.2.3 ÷ 7.5.2.6**, the height of the outside door sill shall be at least 600 mm, and of the inside door sill, at least 230 mm.

7.6.7 In floating docks the height of sills to the top deck access openings in the engine and boiler casings shall be at least 200 mm.

7.7 COMPANION HATCHES, SKYLIGHTS AND VENTILATING TRUNKS

7.7.1 Design and securing.

7.7.1.1 Deck openings in positions 1 and 2 intended for stairways to the ship's spaces located below, as well as light and air openings to these spaces shall be protected by strong companion hatches, skylights or ventilating trunks.

Where the openings intended for stairways to the ship's spaces located below are protected by superstructures or deckhouses instead of companion hatches, these superstructures and deckhouses shall comply with the requirements of **7.5**.

Hatch covers intended for emergency escape to the lifeboat and liferaft embarkation deck (refer to **8.5.1**), shall be constructed in such a manner that the securing devices shall be of a type which can be opened from both sides of the hatch cover, and the maximum force needed to open the hatch cover shall not exceed 150 N. The use of a spring equalizing, counterbalance or other suitable device on the hinge side to reduce the force needed for opening is acceptable.

For oil tankers of 150 m in length and above as well as bulk carriers of 90 m in length and above, contracted for construction on or after 1 July 2015, the requirements for cargo hatch covers are regulated by IACS Common Structural Rules for Bulk Carriers and Oil Tankers.

7.7.1.2 Height of coamings of companion hatches, skylights and ventilating trunks shall be at least 600

mm in position 1 and at least 450 mm in position 2.

In ships of restricted areas of navigation **R3** and **R3-IN** having the length of 24 m and over (except passenger ships) the specified height of coamings may be reduced from 600 mm down to 450 mm and from 450 mm down to 380 mm, respectively.

If the length of the ship is less than 24 m, the height of the coamings may be reduced down to 380 mm for ships of restricted areas of navigation **R2**, **R2-RS**, **R3-S**, **R3-RS**, **B-R3-S**, **B-R3-RS**, **C-R3-S** and down to 300 mm for ships of restricted areas of navigation **R3**, **R3-IN** and **D-R3-S**, **D-R3-RS**.

Height of a coaming may be reduced if such a height would interfere with the normal operation of the ship, provided the seaworthiness and deck wetness assessment is submitted by the designer. Such assessment verifies the ship safety with sea condition in respect to the assigned area of navigation.

Construction of coamings shall comply with the requirements of 2.6.5.2, Part II "Hull" and in case of fiber-reinforced plastic ships, with the requirements of Part XVI "Structure and Strength of Fiber Reinforced Plastic Ships".

7.7.1.3 All the companion hatches, skylights and ventilating trunks shall be provided with covers made of steel or other material approved by the Register and being permanently attached to the coamings.

Where the covers are made of steel, the thickness of their plate shall be equal to at least 0,01 times the spacing of stiffeners, but not less than 6 mm.

For ships of less than 500 gross tonnage, the minimum required thickness of 6 mm may be reduced if the cover is made by stamping in accordance with Fig. 7.7.1.3 and Table 7.7.1.3.

In small ships having the deck thickness less than 6 mm the required minimum thickness 6 mm may be reduced down to the deck thickness regardless of whether the cover is made by stamping, but in no case the plate thickness shall be less than 4 mm.

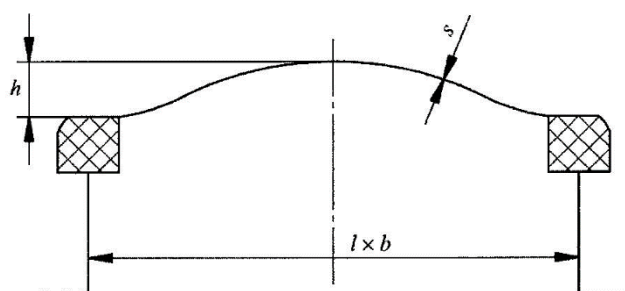

Fig. 7.7.1.3

Table 7.7.1.3 Necessary minimum height and thickness of the cover

Clear sizes of hatches $l \times b$, in mm	Material of cover	Height of stamping h , in mm	Minimum thickness s , in mm
450x600	Steel	25	4
	Light alloy		
600x600	Steel	28	4
	Light alloy		
700x700	Steel	40	4
	Light alloy		6
800x800	Steel	55	4
	Light alloy		6
800x1200	Steel	55	5
	Light alloy		6
1000x1400	Steel	90	5

7.7.1.4 Covers of companion hatches, skylights and ventilating trunks shall have securing devices workable at least from outside of the hatch. However, where the hatches are used as emergency exits in addition to their primary application, the securing device shall be capable of being operated from each side of the cover.

When secured, the covers shall be weathertight. The tightness shall be provided by a rubber or other suitable gasket.

7.7.1.5 The glass for windows in the covers of skylights shall be hardened and at least 6 mm thick if the inner diameter is 150 mm and below, and at least 12 mm with the inner diameter of 450 mm. For intermediate inner diameters, the thickness of glass shall be determined by linear interpolation.

However, where wire-reinforced glass is used, its thickness may be 5 mm, and the requirement relating to its hardening will not be applicable.

Glass shall be efficiently attached to the covers by means of a frame and have on its contour a weathertight gasket of rubber or other equivalent material.

Skylights installed in the machinery spaces of category A, shall comply with the requirements of **2.1.4.2**, Part VI "Fire Protection".

7.7.1.6 Each window or group of adjacent windows shall be provided with portable shields of the same material as the cover being at least 3 mm in thickness and capable of being efficiently fastened outside the cover by means of ear-nuts; such portable shields shall be stowed adjacent to the skylights.

7.7.1.7 In floating docks the height of coamings of companion hatches, skylights and ventilating trunks situated on the top deck shall be at least 200 mm. The portable shields mentioned in **7.7.1.6** need not be provided for covers of skylights situated on the top deck of the floating docks.

7.7.2 Design and securing of small hatches on the exposed for deck.

7.7.2.1 The requirements of **7.7.2** apply to hatches generally having an area of not more than 2,5 m² located on the exposed deck at a distance of $0,25L$ from the fore perpendicular of ships of 80 m in length and more, where the height of the exposed deck in way of the hatch is less than $0,1L$ or 22 m above the summer load waterline, whichever is less. The ship length L is determined according to **1.1.3**, Part II "Hull".

7.7.2.2 For rectangular or square steel hatch covers, the plate thickness, stiffener arrangement and scantlings shall be in accordance with Table 7.7.2.2 and Fig. 7.7.2.2. Stiffeners, where fitted, shall be aligned with contact points of the hatch cover edge with the welded pad (metal-to-metal contact points) required in accordance with 7.7.2.6 (refer to Fig. 7.7.2.2). Primary stiffeners shall be continuous. All stiffeners shall be welded to the inner edge stiffener (refer to Fig. 7.7.2.8).

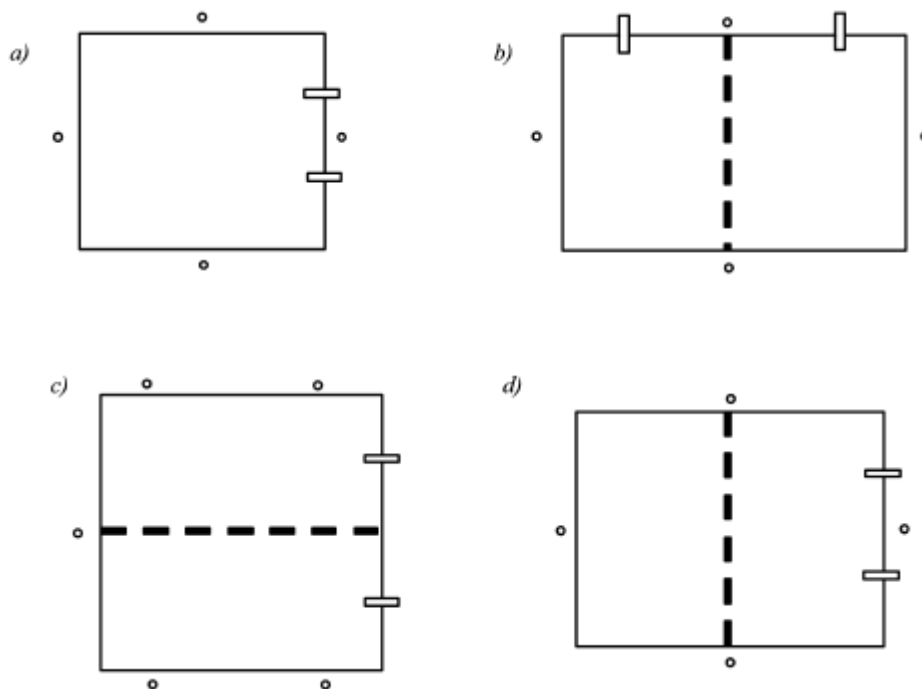

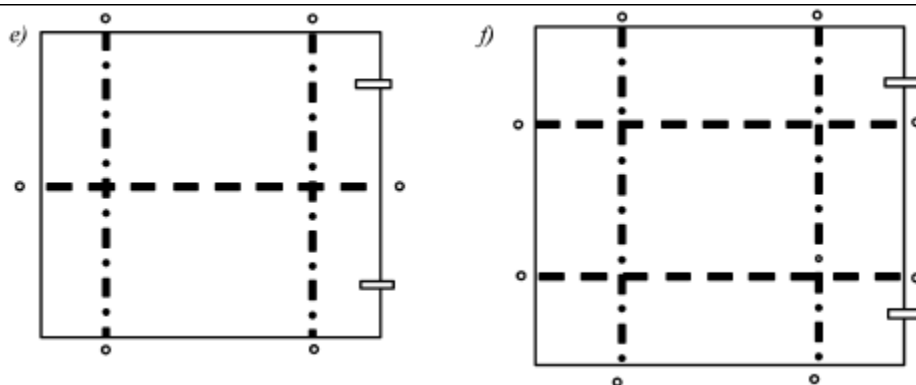

Fig. 7.7.2.2 Nominal sizes of hatch covers:

$a = 630 \times 630$ mm; $b = 630 \times 830$ mm; $c = 830 \times 630$ mm; $d = 830 \times 830$ mm; $e = 1030 \times 1030$ mm; $f = 1330 \times 1330$ mm

Symbols:

- - hinge
- - securing device/metal-to-metal contact;
- - primary stiffener;
- · - · - secondary stiffener

Table 7.7.2.2

Nominal size, mm x mm	Cover plate thickness, in mm	Primary stiffeners	Secondary stiffeners
		Flat bar, mm6mm; number	
630×630	8	–	–
630×830	8	100× 8; 1	–
830×630	8	100× 8; 1	–
830×830	8	100× 10; 1	–
1030×1030	8	120× 12; 1	80× 8; 2
1330× 1330	8	150× 12; 2	100× 10; 2

7.7.2.3 The hatchway coaming shall be suitably reinforced by a horizontal flat bar, normally not more than 170 ÷ 190 mm from the upper edge of the coaming.

7.7.2.4 For hatch covers constructed of materials other than steel, the required scantlings shall provide equivalent strength.

7.7.2.5 Weathertightness of hatch covers shall be ensured by securing devices of the following types: butterfly nuts tightening onto forks (clamps); quick acting cleats; central locking device. Dogs (twist tightening handles) with wedges are not acceptable.

Where the hatch covers are also used as emergency exits, they shall be also fitted with the central quick acting locking device designed for handling on both sides.

7.7.2.6 The hatch cover shall be fitted with a gasket of elastic material. This shall be designed to allow a contact of the hatch cover edge to the welded pad (metal-to-metal contact) at a designed compression and to prevent over compression of the gasket by green sea forces that may cause the securing devices to be loosened or dislodged. The contacts of the hatch cover edge to the welded pad (metal-to-metal contact) shall be arranged close to each securing device in accordance with Fig. 7.7.2.2, and shall be of sufficient capacity to withstand the bearing force.

7.7.2.7 The primary securing device shall be designed and manufactured so that the designed compression pressure is achieved by one person without the need of any tools.

7.7.2.8 Where butterfly nuts are used in the primary securing device, the forks (clamps) shall be of the robust design, which minimizes the risk of the butterfly nuts being dislodged while in use. It is ensured by curving the forks upward, a raised surface on the free end, or a similar method (refer to Fig. 7.7.2.8).

The plate thickness of unstiffened steel forks (clamps) shall not be less than 16 mm.

7.7.2.9 For hatch covers located on the exposed deck forward of the fore-most cargo hatch, the hinges shall be fitted such that the predominant direction of green sea will cause the cover to close, which means that the hinges are normally to be located on the fore edge.

7.7.2.10 On hatches located between the cargo hatches, the hinges shall be placed on the fore edge or outboard edge, whichever is practicable for protection from green water in beam sea and bow quartering conditions.

7.7.2.11 Hatches, excepting those which may also be used as emergency exits, shall be fitted with an independent secondary securing device like, e.g. a sliding bolt, a hasp or a backing bar of slack fit, which is capable of keeping the hatch cover in place, even in the event that the primary securing device became loosened or dislodged. It shall be fitted on the side opposite to the hatch cover hinges.

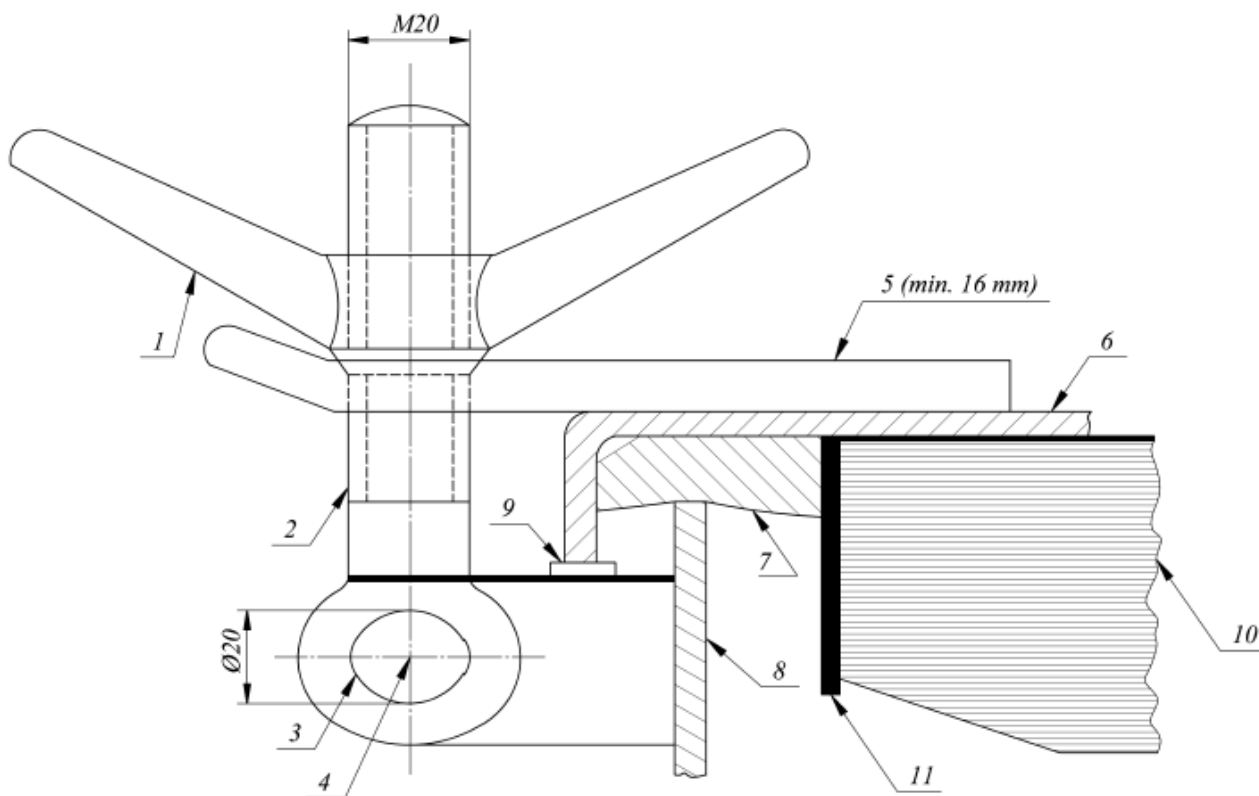

Fig. 7.7.2.8.

1 – butterfly nut; 2 – bolt; 3 – pin; 4 – centre of pin; 5 – fork (damp) plate; 6 – hatch cover; 7 – gasket; 8 – hatch coaming; 9 – bearing pad welded on the bracket for metal-to-metal contact; 10 – stiffener; 11 – inner edge stiffener.

7.8 VENTILATORS

7.8.1 Ventilators to spaces below freeboard deck or deck of enclosed superstructures and deckhouses shall be fitted with coamings efficiently connected to the deck.

The coamings of ventilators shall be at least 900 mm in height in position 1 and at least 760 mm in position 2.

In ships of restricted areas of navigation **R3** and **R3-IN** having the length of 24 m and over (except passenger ships) the specified height of the coamings may be reduced from 900 mm down to 760 mm and from 760 mm down to 600 mm, respectively.

In ships of restricted areas of navigation **R2**, **R2-RS**, **R3-S**, **R3-RS**, **B-R3-S**, **B-R3-RS**, **C-R3-S**, **R3**, **R3-IN** and **D-R3-S**, **D-R3-RS** having the length below 24 m the height of the coamings may be reduced down to 300 mm for all open decks.

Construction of coamings shall comply with the requirements of **2.6.5.2**, Part II "Hull".

The strength of ventilators, connections of ventilators to coamings and connections of ventilator parts, if

any, shall be equivalent to that of the coaming.

7.8.2 Ventilators in position 1 the coamings of which extend to more than 4500 mm above the deck and in position 2 the coamings of which extend to more than 2300 mm above the deck need not be fitted with closing appliances.

In all other cases, each ventilator shall be fitted with a strong cover made of steel or other material approved by the Register.

In ships of less than 100 m in length, the covers shall be permanently attached; in ships of 100 m in length and over they may be conveniently stowed near the ventilators to which they shall be fitted.

7.8.3 When secured, the covers of ventilators shall be weathertight. The tightness shall be provided by a rubber or other suitable gasket.

7.8.4 In supply vessels, in order to minimize the possibility of flooding of the spaces situated below, the ventilators shall be positioned in the protected locations where the probability of their damage by cargo is excluded during cargo handling operations. Particular attention shall be given to the arrangement of ventilators of the engine and boiler rooms for which the location is preferable above the deck level of the first tier of superstructures or deckhouses.

7.8.5 In floating docks the height of coamings of ventilators situated on the top deck shall be at least 200 mm.

7.9 MANHOLES

7.9.1 The height of coamings of manholes for deep and other tanks, except for those indicated in **2.4.5.3**, Part II "Hull", air spaces, cofferdams, etc. is not regulated by the Register.

7.9.2 Covers of manholes shall be made of steel or other material approved by the Register.

The thickness of the covers shall not be less than that of the plating on which they are fitted. The thickness of the covers, where the thickness of plating is greater than 12 mm, may be reduced based on appropriate technical background confirming that covers have a sufficient strength.

7.9.3 The covers of manholes shall be efficiently attached to the coaming or doubling ring by means of bolts or pins with nuts.

7.9.4 When secured, the covers shall be tight both for water and liquid cargoes or stores for which the tanks are intended under the inner pressure corresponding to the test pressure of the tank under consideration.

The tightness shall be provided by a rubber or other suitable gasket.

The gasket shall be resistant to the liquids referred to above.

7.10 HATCHWAYS OF DRY CARGO HOLDS

7.10.1 General.

The deck openings through which cargoes or ship's stores are loaded and unloaded shall be protected by strong hatchways. If these hatchways are situated in positions 1 and 2, the hatchway covers shall be weathertight. The tightness shall be provided by one of the following two methods:

.1 by portable covers and tarpaulins as well as battening devices;

.2 by weathertight covers made of steel or other equivalent material fitted with rubber or other suitable gaskets and clamping devices.

7.10.2 Coamings.

7.10.2.1 The height of hatchway coamings in positions 1 and 2 shall be at least 600 mm and 450 mm, respectively.

If the length of the ship is less than 24 m, the height of the coamings may be reduced down to 380 mm for ships of restricted area of navigation **R2**, **R2-RS**, **R3-S**, **R3-RS**, **B-R3-S**, **B-R3-RS**, **C-R3-S** and down to 300 mm for ships of restricted areas of navigation **R3**, **R3-IN** and **D-R3-S**, **D-R3-RS**.

In fishing vessels the height of cargo hatchway coamings in position 2 may be reduced down to 300 mm.

In ships of restricted areas of navigation **R3** i **R3-IN** having the length of 24 m and over (except passenger ships) the specified height of cargo hatchway coamings may be reduced from 600 mm down to 450 mm and from 450 mm down to 380 mm, respectively.

7.10.2.2 The height of coamings of the hatchways specified in **7.10.1.2** may be decreased in relation to that prescribed by **7.10.2.1** or the coamings may be omitted entirely where the efficiency of the cover tightness and securing means will satisfy the Register.

7.10.3 Materials.

7.10.3.1 For steel of top plate, bottom plate and primary supporting members, refer to 1.6.

7.10.3.2 The wood of hatchway covers shall be of good quality and of the type and grade which proved

to be satisfactory for this purpose. Wedges shall be of hard wood.

7.10.3.3 Canvas used for making tarpaulins shall be impregnated to make them moisture-resistant and shall not contain jute thread. Mass of 1 m² of canvas before impregnation shall be not less than 0,55 kg. Breaking stress of impregnated canvas band 200x50 mm in size shall be at least 3 kN and 2 kN in longitudinal and transverse directions, respectively. When tested for watertightness, the impregnated canvas shall not get wet under water head of 0,15 m acting for 24 h.

7.10.3.4 The rubber for packing gaskets of hatchway covers shall be elastic, strong, and resistant to atmospheric changes. The rubber shall be of sufficient hardness.

7.10.3.5 All internal and external surfaces of steel hatch covers in bulk carriers (except inaccessible spaces in box type covers) shall have effective epoxy or other equivalent protective coating applied in accordance with the recommendations of the manufacturer (refer to **1.1.4.7** and **3.3.5.1**, Part II "Hull").

7.10.4 Design loads.

Hatchway covers shall be designed to sustain deck cargoes which are intended to be carried on these covers. Where operation of the cargo handling cars on hatchways covers is anticipated in the course of the ship's service, during cargo handling operations, the loads induced by such cars shall be taken into consideration. For hatchway covers in positions 1 and 2 the design load and design of hatch covers shall comply with the requirements of Regulation 16 of International Convention on Load Lines, 1966, as modified by the 1988 Protocol relating thereto with further amendments (LL 66/88)..

For ships of less than 24 m in length of restricted area of navigation engaged on international voyages and for all ships of restricted area of navigation not engaged on international voyages instead of load intensity specified in Regulation 16 of International Convention on Load Lines, 1966, as modified by the 1988 Protocol relating thereto with further amendments (LL 66/88) the load intensity reduced by the following values may be used:

15 % for ships of restricted areas of navigation **R2, R2-RS, R3-S, R3-RS, B-R3-S, B-R3-RS,**

C-R3-S;

30 % for ships of restricted areas of navigation **R3, R3-IN** та **D-R3-S, D-R3-RS**, but not less than the load intensity on the weather deck in the area of hatches installation, determined in accordance with 2.6.3.1, Part II "Hull".

7.10.5 Design of hatch covers specified in 7.10.1.1.

Design of these hatch covers shall meet the requirements of Regulation 15 of International Convention on Load Lines, 1966, as modified by the 1988 Protocol relating thereto with further amendments (LL 66/88).

7.10.6 Structure of hatch covers indicated in 7.10.1.2.

7.10.6.1 Structure of these covers shall meet the requirements of 3.2.5 of the Load Line Rules for SeaGoing Ships.

7.10.6.2 Primary supporting members and secondary stiffeners of hatch covers shall be continuous over the breadth and length of hatch covers, as far as practical. When this is impractical, sniped end connections shall not be used and appropriate arrangements shall be adopted to provide sufficient load carrying capacity.

7.10.6.3 The spacing of primary supporting members parallel to the direction of secondary stiffeners shall not exceed 1/3 of the span of primary supporting members. When strength calculation is carried out by FE analysis using plane strain or shell elements, this requirement can be waived.

Secondary stiffeners of hatch coamings shall be continuous over the breadth and length of hatch coamings.

7.10.6.4 Unless otherwise quoted, the thickness t of the following sections is the net thickness.

Net thickness is the member thickness necessary to obtain the minimum net scantlings.

The required gross thicknesses are obtained by adding corrosion additions t_s .

Strength calculations using beam theory, grillage analysis or FEM shall be performed with net scantlings.

7.10.6.5 Structural assessment of hatch covers and hatch coamings shall be carried out using the design loads, defined in this Chapter and the following definitions shall be used:

L – length of ship, in m, as defined in **1.1.3**, Part II "Hull";

L_{LL} – length of ship, in m, as defined in **1.2.2**;

x – longitudinal coordinate of mid point of assessed structural member measured from aft end of length L or L_{LL} , as applicable;

D_{\min} – the least moulded depth, in m, as defined in International Convention on Load Lines, 1966, as modified by the 1988 Protocol relating thereto with further amendments (LL 66/88).

h_N – standard superstructure height, in m,

$h_N = 1,05 + 0,01 L_{LL}$, and $1,8 \leq h_N \leq 2,3$.

7.10.6.6 The pressure p_H , in kN/m^2 , on the hatch cover panels is given in Table 7.10.6.6. The vertical weather design load needs not to be combined with cargo loads.

In Fig. 7.10.6.6 positions 1 and 2 are illustrated for an example ship.

Table 7.10.6.6 Design load p_H of weather deck hatch covers

Position	Design load p_H , in kN/m^2	
	$x/L_{LL} \leq 0,75$	$0,75 < x/L_{LL} \leq 1,0$
1	for $24 \text{ m} \leq L_{LL} \leq 100 \text{ m}$	
	$(9,81/76)(1,5L_{LL}+116)$	on freeboard deck: $(9,81/76)[(4,28L_{LL}+28)(x/L_{LL})-1,71L_{LL}+95]$;
		upon exposed superstructure decks located at least one superstructure standard height above the freeboard deck: $(9,81/76)(1,5L_{LL}+116)$
	for $L_{LL} > 100 \text{ m}$	
	$9,81 \times 3,5$	on freeboard deck for type B ships according to the International Convention on Load Lines (LL 66/88): $9,81[(0,0296L_1+3,04)(x/L_{LL}) - 0,0222L_1+1,22]$;
		on freeboard deck for ships with less freeboard than type B according to the International Convention on Load Lines (LL 66/88): $9,81[(0,1452L_1+8,52)(x/L_{LL}) - 0,1089L_1 + 9,89]$, $L_1 = L_{LL}$, but not more than 340 m;
upon exposed superstructure decks located at least on superstructure standard height above the freeboard deck: $9,81 \times 3,5$		
2	for $24 \text{ m} \leq L_{LL} \leq 100 \text{ m}$	
	$(9,81/76)(1,1L_{LL}+87,6)$	
	for $L_{LL} > 100 \text{ m}$	
	$9,81 \times 2,6$;	
upon exposed superstructure decks located at least one superstructure standard height above the lowest position 2 deck: $9,81 \times 2,1$		

7.10.6.7 Where an increased freeboard is assigned, the design load for hatch covers according to Table 7.10.6.6 on the actual freeboard deck may be as required for a superstructure deck, provided the summer freeboard is such that the resulting draught will not be greater than that corresponding to the minimum freeboard calculated from an assumed freeboard deck situated at a distance at least equal to the standard superstructure height h_N below the actual freeboard deck (refer to Fig. 7.10.6.6).

Positions 1 and 2

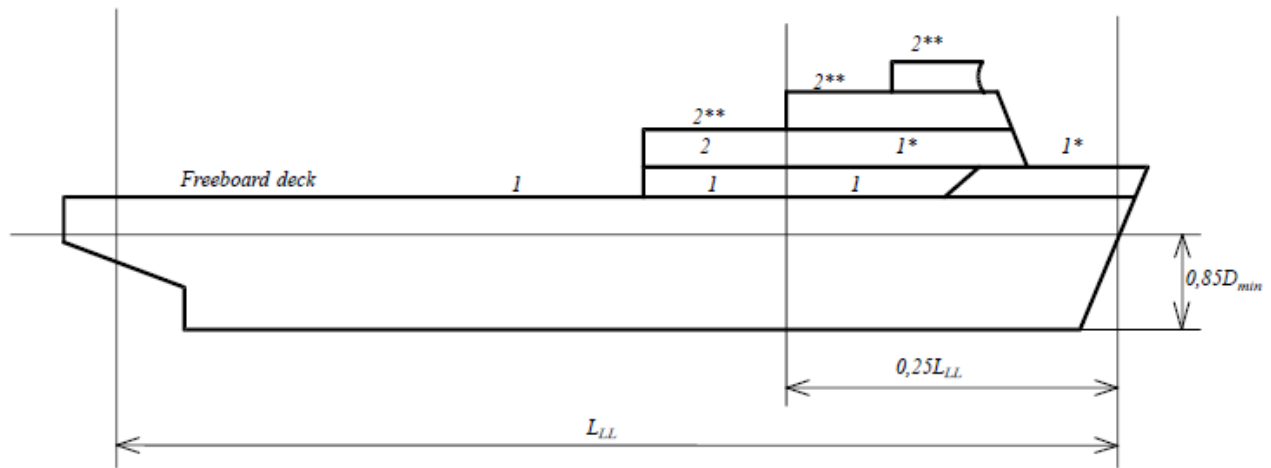

Positions 1 and 2 for an increased freeboard

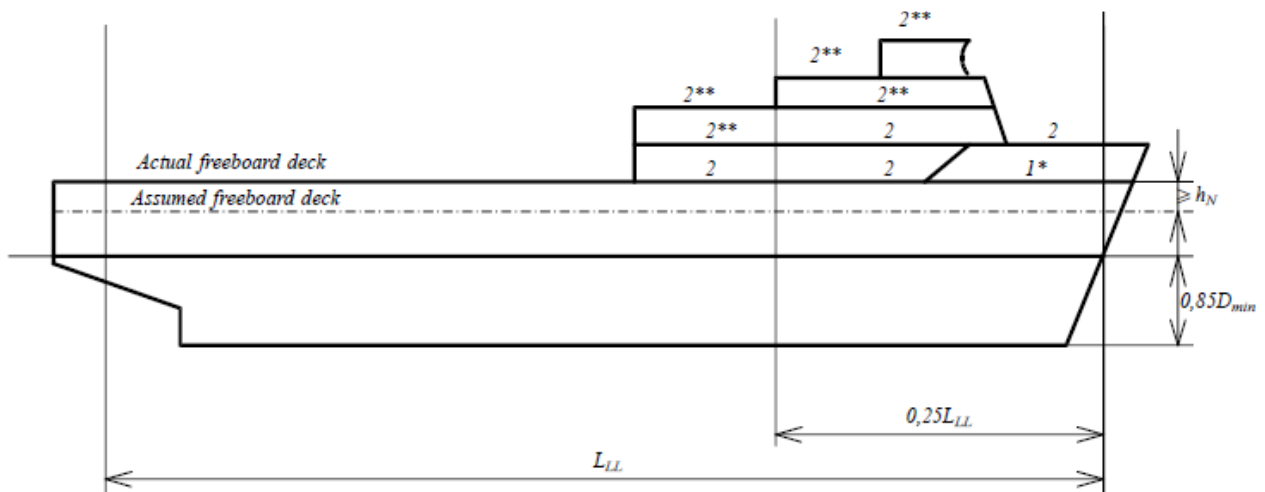

Fig. 7.10.6.6

Примітки: * Reduced load upon exposed superstructure decks located at least one superstructure standard height above the freeboard deck.

** Reduced load upon exposed superstructure decks of ships with $L_{LL} > 100$ m, located at least one superstructure standard height above the lowest position 2 deck.

7.10.6.8 The horizontal weather design load p_A , in kN/m^2 , for determining the scantlings of outer edge girders (skirt plates) of weather deck hatch covers and of hatch coamings shall be determined by the formula:

$$p_A = ac(bc_L f - z), \quad (7.10.6.8)$$

where:

$$f = L/25 + 4,1, \quad \text{for } L < 90 \text{ m};$$

$$f = 10,75 - [(300-L)/100]^{1,5}, \quad \text{for } 90\text{m} \leq L < 300 \text{ m};$$

$$f = 10,75, \quad \text{for } 300\text{m} \leq L < 350 \text{ m};$$

$$f = 10,75 - [(L-350)/150]^{1,5}, \quad \text{for } 350 \text{ m} \leq L < 500 \text{ m};$$

$$c_L = (L/90)^{0,5}, \quad \text{for } L < 90 \text{ m};$$

$$c_L = 1, \quad \text{for } L \geq 90 \text{ m};$$

$$a = 20 + (L/12) \text{ for unprotected front coamings and hatch cover skirt plates};$$

$a = 10 + (L/12)$ for unprotected front coamings and hatch cover skirt plates, where the distance from the actual freeboard deck to the summer load line exceeds the minimum non-corrected tabular freeboard according to the International Convention on Load Lines, 1966, as modified by the 1988 Protocol relating thereto with further amendments (LL 66/88) (LL 66/88) by at least one standard superstructure height h_N ;

$$a = 5 + (L/15) \text{ for side and protected front coamings and hatch cover skirt plates};$$

$$a = 7 + (L/100) - (8x'/L) \text{ for aft ends of coamings and aft hatch cover skirt plates abaft amidships};$$

$$a = 5 + (L/100) - (4x'/L) \text{ for aft ends of coamings and aft hatch cover skirt plates forward of amidships};$$

$$L_1 = L, \text{ need not be taken greater than } 300 \text{ m};$$

$$b = 1,0 + \{[(x'/L) - 0,45] / (C_B + 0,2)\}^2, \quad \text{for } (x'/L) < 0,45;$$

$$b = 1,0 + 1,5 \{[(x'/L) - 0,45] / (C_B + 0,2)\}^2, \quad \text{for } (x'/L) \geq 0,45;$$

$0,6 \leq C_B \leq 0,8$, when determining scantlings of aft ends of coamings and aft hatch cover skirt plates forward of amidships, C_B need not be taken less than 0,8;

x' – distance, in m, between the transverse coaming or hatch cover skirt plate considered and aft end of the length L .

When determining side coamings or side hatch cover skirt plates, the side shall be subdivided into parts of approximately equal length, not exceeding $0,15L$ each, and x' shall be taken as the distance between aft end of the length L and the centre of each part considered;

z – vertical distance, in m, from the summer load line to the midpoint of stiffener span, or to the middle of the plate field;

$$c = 0,3 + 0,7(b'/B');$$

b' – breadth of coaming, in m, at the position considered;

B' – actual maximum breadth of ship, in m, on the exposed weather deck at the position considered;

(b'/B') – shall not be taken less than 0,25.

The design load p_A shall not be taken less than the minimum values given in Table 7.10.6.8.

Table 7.10.6.8. Minimum design load p_{Amin}

L	p_{Amin} , in kN/m ² , for	
	unprotected fronts	elsewhere
≤ 50	30	15
> 50	$25 + (L/10)$	$12,5 + (L/20)$
< 250		
≥ 250	50	25

Note. The horizontal weather design load need not be included in the direct strength calculation of the hatch cover, unless it is utilized for the design of substructures of horizontal support according to 7.10.6.51.

7.10.6.9 The load on hatch covers due to distributed cargo loads P_L , in kN/m², resulting from heave and pitch (i.e. ship in upright condition) shall be determined according to the following formula:

$$p_1 = p_c (1 + a_v), \quad (7.10.6.9)$$

where:

p_c – uniform cargo hold, in kN/m^2 ;

a_v – vertical acceleration addition as follows:

$$a_v = Fm;$$

where: $F = 0,11v_0/(L)^{0,5}$;

$$m = m_0 - 5(m_0 - 1)(x/L), \quad \text{for } 0 \leq (x/L) \leq 0,2;$$

$$m = 1, \quad \text{for } 0,2 < (x/L) \leq 0,7;$$

$$m = 1 + [(m_0 + 1)/0,3][(x/L) - 0,7], \quad \text{for } 0,7 < (x/L) \leq 1,0;$$

where: $m_0 = 1,5 + F$;

v_0 – maximum speed at summer load line draught;

v_0 shall not be taken less than $(L)^{0,5}$, in knots.

7.10.6.10 The load P , in kN , due to a concentrated force P_S , in kN , except for container load, resulting from heave and pitch (i.e. ship in upright condition) shall be determined as follows:

$$P = P_S(1 + a_v), \quad (7.10.6.10)$$

where:

a_v – acceleration addition according to **7.10.6.9**.

7.10.6.11 The loads defined in **7.10.6.11.1** shall be applied where containers are stowed on the hatch cover.

7.10.6.11.1 The load P , in kN , applied at each corner of a container stack, and resulting from heave and pitch (i.e. ship in upright condition) shall be determined as follows:

$$P = 9,81 \cdot M \cdot (1 + a_v)/4, \quad (7.10.6.11.1-1)$$

where: a_v – acceleration addition according to **7.10.6.9**;

M – maximum designed mass of container stack, in t ;

7.10.6.11.2 The loads, in kN , applied at each corner of a container stack, and resulting from heave, pitch, and the ship's rolling motion (i.e. ship in heel condition) shall be determined as follows, (refer also to Fig. 7.10.6.11):

$$A_z = 9,81(M/2)(1 + a_v)[0,45 - 0,42(h_m/b)]; \quad (7.10.6.11.2-1)$$

$$B_z = 9,81(M/2)(1 + a_v)[0,45 + 0,42(h_m/b)]; \quad (7.10.6.11.2-2)$$

$$B_y = 2,4M, \quad (7.10.6.11.2-3)$$

where:

a_v – acceleration addition according to **7.10.6.9**;

M – maximum designed mass of container stack, in t ;

h_m – designed height of centre of gravity of stack above hatch cover top, in m , may be calculated as weighted mean value of the stack, where the centre of gravity of each tier is assumed to be located at the centre of each container,

$$h_m = \sum(z_i \cdot W_i)/M;$$

z_i – distance from hatch cover top to the centre of i -th container, in m ;

W_i – weight of i -th container, in t ;

b – distance between midpoints of foot points, in m , refer to Fig. 7.10.6.11;

A_z, B_z – support forces in Z -direction at the forward and aft stack corners;

B_y – support force in y -direction at the forward and aft stack corners.

When strength of the hatch cover structure is assessed by grillage analysis according to 7.10.6.21, h_m and z_i shall be taken as shown in Fig. 7.10.6.11.

Force B_y does not need to be considered in this case.

Values of A_z and B_z , applied for the assessment of hatch cover strength shall be shown in the drawings of the hatch covers.

Note. It is recommended that container loads as calculated above are considered as limit for foot point loads of container stacks in the calculations of cargo securing (container lashing).

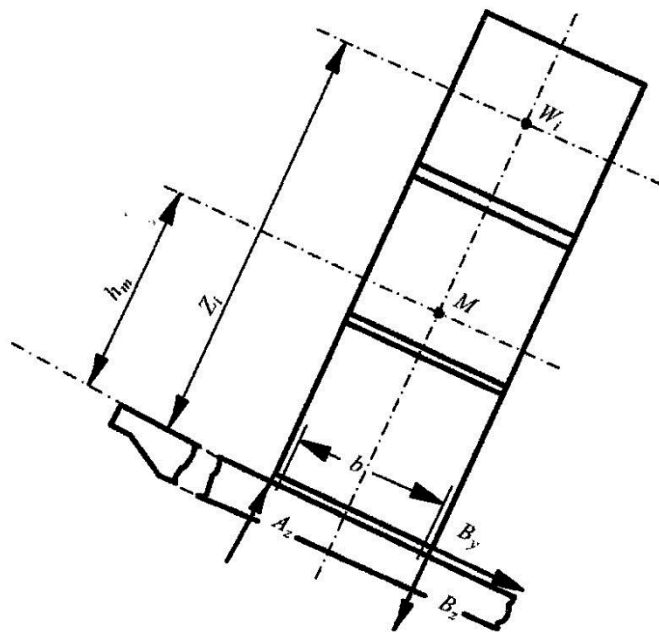

Fig. 7.10.6.11 Forces due to container loads

7.10.6.12 The load cases defined in 7.10.6.11.1 and 7.10.6.11.2, shall also be considered for partial non homogeneous loading which may occur in practice, e.g. where specified container stack places are empty.

For each hatch cover, the heel directions, as shown in Table 7.10.6.12 shall be considered.

The load case partial loading of container hatch covers can be evaluated using a simplified approach, where the hatch cover is loaded without the outermost stacks that are located completely on the hatch cover.

If there are additional stacks that are supported partially by the hatch cover and partially by container stanchions then the loads from these stacks shall also be neglected, refer to Table 7.10.6.12.

In addition, the case where only the stack places supported partially by the hatch cover and partially by container stanchions are left empty shall be assessed in order to consider the maximum loads in the vertical hatch cover supports.

Table 7.10.6.12 Partial loading of container hatch covers

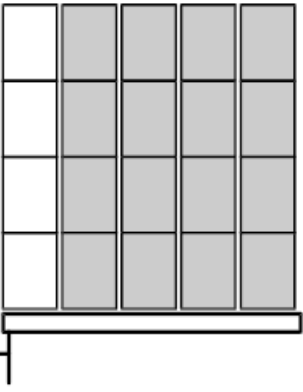
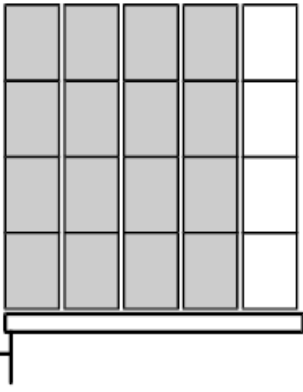
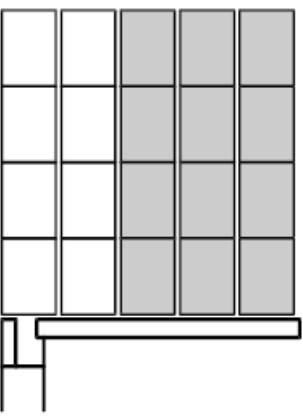
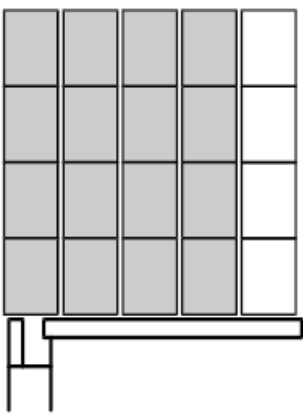
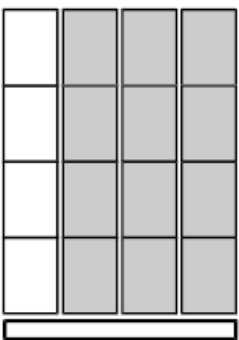
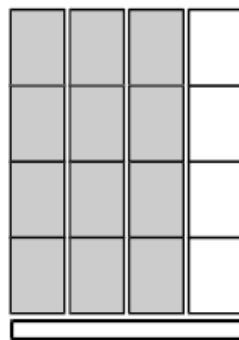
Heel direction	←	→
Hatch covers supported by the longitudinal hatch coaming with all container stacks located completely on the hatch cover		
Hatch covers supported by the longitudinal hatch coaming with the outermost container stack supported partially by the hatch cover and partially by container stanchions		
Hatch covers not supported by the longitudinal hatch coaming (center hatch covers)		

It may be necessary also to consider partial load cases where more or different container stack places are left empty.

In the case of mixed stowage e (20' + 40' container combined stack), the foot point forces at the fore and aft end of the hatch cover shall not be higher than resulting from the design stack weight for 40' containers, and the foot point forces at the middle of the cover shall not be higher than resulting from the design stack weight for 20' containers.

7.10.6.13 Hatch covers, which in addition to the loads according to **7.10.6.6**, **7.10.6.7** and **7.10.6.11**, are loaded in the ship's transverse direction by forces due to elastic deformations of the ship's hull, shall be designed such that the sum of stresses does not exceed the permissible values given in **7.10.6.14**.

7.10.6.14 The equivalent stress σ_V in steel hatch cover structures related to the net thickness shall not exceed $0,8\sigma_F$, where σ_F is the minimum yield stress, in N/mm^2 .

For design loads according to **7.10.6.8** ÷ **7.10.6.13**, the equivalent stress s_v related to the net thickness shall not exceed $0,9\sigma_F$, when the stresses are assessed by means of FEM.

For grillage analysis, the equivalent stress may be taken as follows:

$$\sigma_v = \sqrt{\sigma^2 + 3\tau^2}, \text{ H/MM}^2, \quad (7.10.6.14-1)$$

where:

σ – normal stress, in N/mm²;

τ – shear stress, in N/mm².

For FEM calculations, the equivalent stress may be taken as follows:

$$\sigma_v = \sqrt{\sigma_x^2 - \sigma_x\sigma_y + \sigma_y^2 + 3\tau_{xy}^2}, \text{ H/MM}^2, \quad (7.10.6.14-2)$$

where:

σ_x – normal stress, in N/mm², in x -direction;

σ_y – normal stress, in N/mm², in y -direction;

τ – shear stress, in N/mm², in x - y plane.

Indices x and y are coordinates of a two-dimensional Cartesian system in the plane of the considered structural element.

In case of FEM calculations using shell or plane strain elements, the stresses shall be read from the centre of the individual element. It shall be observed that, in particular, at flanges of unsymmetrical girders, the evaluation of stress from element centre may lead to non-conservative results.

Thus, a sufficiently fine mesh shall be applied in these cases or, the stress at the element edges shall not exceed the allowable stress.

Where shell elements are used, the stresses shall be evaluated at the mid plane of the element.

7.10.6.15 The vertical deflection of primary supporting members due to the vertical weather design load according to **7.10.6.6** and **7.10.6.7** shall not be more than $0,0056l_g$, where l_g is the greatest span of primary supporting members.

Where hatch covers are arranged for carrying containers and mixed stowage is allowed, i.e., a 40' container stowed on top of two 20' containers, particular attention shall be paid to the deflections of hatch covers. Further the possible contact of deflected hatch covers with in hold cargo shall be observed.

7.10.6.16 The local net plate thickness t , in mm, of the hatch cover top plating shall not be less than:

$$t = F_p 15,8s(p/0,95\sigma_F)^{0,5}, \quad (7.10.6.16)$$

and shall not be less than 1 % of the spacing of the stiffener or 6 mm if that be greater,

where:

p – pressure p_N and p_1 , in kN/m², as defined in **7.10.6.6** and **7.10.6.9**;

$F_p = 1,5$ in general;

$F_p = 1,9\sigma/\sigma_a$ for $\sigma/\sigma_a \geq 0,8$ for the attached plate flange of primary supporting members;

s – stiffener spacing, in m;

σ_F – minimum yield stress of the material, in N/mm²;

σ – maximum normal stress, in N/mm², of hatch cover top plating, determined according to Fig.7.10.6.16;

$\sigma_a = 0,8 \sigma_F$, in N/mm².

For flange plates under compression sufficient buckling strength according to **7.10.6.24** shall be demonstrated.

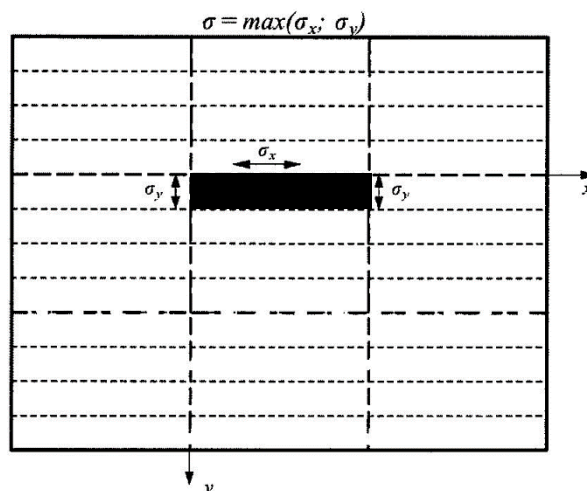

Fig. 7.10.6.16

7.10.6.17 The thickness of lower plating of double skin hatch covers and box girders shall fulfill the strength requirements and shall be obtained from the calculation according to 7.10.6.21 under consideration of permissible stresses according to 7.10.6.14.

When the lower plating is taken into account as a strength member of the hatch cover, the net thickness, in mm, of lower plating shall be taken not less than 5 mm.

When project cargo is intended to be carried on a hatch cover, the net thickness shall not be less than:

$$t = 6,5s, \text{ mm}; \quad (7.10.6.17)$$

where:

s – stiffener spacing, in m.

Note. Project cargo means especially large or bulky cargo lashed to the hatch cover. Examples are parts of cranes or wind power stations, turbines, etc. Cargoes that can be considered as uniformly distributed over the hatch cover, e.g., timber, pipes or steel coils need not to be considered as project cargo.

7.10.6.18 The net section modulus Z and net shear area A_s of uniformly loaded hatch cover stiffeners constraints at both ends shall not be less than:

$$Z = (104/\sigma_F) \cdot s \cdot l^2 \cdot p, \text{ in cm}^3, \quad (7.10.6.18-1)$$

for design load according to 7.10.6.6;

$$Z = (94/\sigma_F) \cdot s \cdot l^2 \cdot p, \text{ in cm}^3, \quad (7.10.6.18-2)$$

for design load according to 7.10.6.9;

$$A_s = (10,8/\sigma_F) \cdot s \cdot l \cdot p, \text{ in cm}^2, \quad (7.10.6.18-3)$$

for design load according to 7.10.6.6;

$$A_s = (9,6/\sigma_F) \cdot s \cdot l \cdot p, \text{ in cm}^2, \quad (7.10.6.18-4)$$

for design load according to 7.10.6.9,

where:

p – pressure p_N and p_1 , in kN/m^2 , as defined in 7.10.6.6 and 7.10.6.9;

s – secondary stiffener spacing, in m;

σ_F – minimum yield stress of the material, in N/mm^2 ;

l – secondary stiffener span, in m, to be taken as the spacing, in m, of primary supporting members or the distance between a primary supporting member and the edge support, as applicable.

For secondary stiffeners of lower plating of double skin hatch covers, requirements mentioned above are not applied due to the absence of lateral loads.

The net thickness, in mm, of the stiffener (except U-beams/trapeze stiffeners) web shall be taken not less than 4 mm.

The net section modulus of the secondary stiffeners shall be determined based on and attached plate width assumed equal to the stiffener spacing.

For flat bar secondary stiffeners and buckling stiffeners, the ratio h/t_w shall not be greater than $15 k^{0.5}$,

where:

h - height of the stiffener;

t_w - net thickness of the stiffener;

$k = 235/\sigma_F$.

Stiffeners parallel to primary supporting members and arranged within the effective breadth according to 7.10.6.22 shall be continuous at crossing primary supporting member and may be regarded for calculating the cross sectional properties of primary supporting members. It shall be verified that the combined stress of those stiffeners induced by the bending of primary supporting members and lateral pressures does not exceed the permissible stresses according to 7.10.6.14.

These requirements are not applied to stiffeners of lower plating of double skin hatch covers if the lower plating is not considered as strength member.

For hatch cover stiffeners under compression sufficient safety against lateral and torsional buckling according to 7.10.6.28 ÷ 7.10.6.32 shall be verified.

For hatch covers subject to wheel loading or point loads stiffener scantlings shall be determined under consideration of the permissible stresses according to 7.10.6.14.

7.10.6.19 Scantlings of primary supporting members are obtained from calculations according to 7.10.6.22 and 7.10.6.23 under consideration of permissible stresses according to 7.10.6.14.

For all components of primary supporting members sufficient safety against buckling shall be verified according to 7.10.6.24 ÷ 7.10.6.32.

For biaxial compressed flange plates this shall be verified within the effective widths according to 7.10.6.29.

The net thickness, in mm, of webs of primary supporting members shall not be less than:

$t = 6,5s$, in mm;

$t_{\min} = 5$ in mm,

where:

s – stiffener spacing, in m.

7.10.6.20 Scantlings of edge girders are obtained from the calculations according to 7.10.6.22 and 7.10.6.23 under consideration of permissible stresses according to 7.10.6.14.

The net thickness, in mm, of the outer edge girders exposed to wash of sea shall not be less than the largest of the following values:

$$t = 15,8s(p_A/0,95\sigma_F)^{0,5}; \quad (7.10.6.20-1)$$

$t = 8,5s$, in mm;

$t_{\min} = 5$ in mm,

where: p_A – horizontal pressure as defined in 7.10.6.8;

σ_F – minimum yield stress of the material, in N/mm²;

s – stiffener spacing, in m.

The stiffness of edge girders shall be sufficient to maintain adequate sealing pressure between securing devices.

The moment of inertia I , in cm⁴, of edge girders shall not be less than

$$I = 6qs_{SD}^4, \text{ in cm}^4, \tag{7.10.6.20-2}$$

where: q – packing line pressure, in N/mm, min = 5 N/mm;
 s_{SD} – spacing, in m, of securing devices.

7.10.6.21 Strength calculation for hatch covers may be carried out by either grillage analysis or FEM. Double skin hatch covers or hatch covers with box girders shall be using FEM, refer to **7.10.6.23**.

7.10.6.22 Cross-sectional properties shall be determined considering the effective breadth. Cross sectional areas of secondary stiffeners parallel to the primary supporting member under consideration within the effective breadth can be included, refer to Fig. 7.10.6.29-1.

The effective breadth of plating e_m of primary supporting members shall be determined according to Table 7.10.6.22, considering the type of loading.

Special calculations may be required for determining the effective breadth of one-sided or non-symmetrical flanges.

The effective cross sectional area of plates shall not be less than the cross sectional area of the face plate.

Table 7.10.6.22. Effective breadth e_m of plating of primary supporting members

l/e	0	1	2	3	4	5	6	7	≥ 8
e_{m1}/e	0	0,36	0,64	0,82	0,91	0,96	0,98	1,00	1,00
e_{m2}/e	0	0,20	0,37	0,52	0,65	0,75	0,84	0,89	0,90

e_{m1} - shall be applied where primary supporting members are loaded by uniformly distributed loads or else by not less than 6 equally spaced single loads.
 e_{m2} - shall be applied where primary supporting members are loaded by 3 or less single loads.
 Intermediate values may be obtained by direct interpolation.
 l – length of zero-points of bending moment curve.
 $l = l_0$ – for simply supported primary supporting members.
 $l = 0,6l_0$ – for primary supporting members with both ends constraint, where l_0 is the unsupported length of the primary supporting member:
 e – width of plating supported, measured from centre to centre of the adjacent unsupported fields.

For flange plates under compression with secondary stiffeners perpendicular to the web of the primary supporting member, the effective width shall be determined according to **7.10.6.29**.

7.10.6.23 For strength calculations of hatch covers by means of finite elements, the cover geometry shall be idealized as realistically as possible. Element size shall be appropriate to account for effective breadth.

In no case element width shall be larger than stiffener spacing. In way of force transfer points and cutouts the mesh shall be refined, where applicable. The ratio of element length to width shall not exceed 4.

The element height of webs of primary supporting member shall not exceed one-third of the web height.

Stiffeners, supporting plates against pressure loads, shall be included in the idealization. Stiffeners may be modelled by using shell elements, plane stress elements or beam elements.

Buckling stiffeners may be disregarded for the stress calculation.

7.10.6.24 For hatch cover structures sufficient buckling strength shall be demonstrated (refer to Fig. 7.10.6.24).

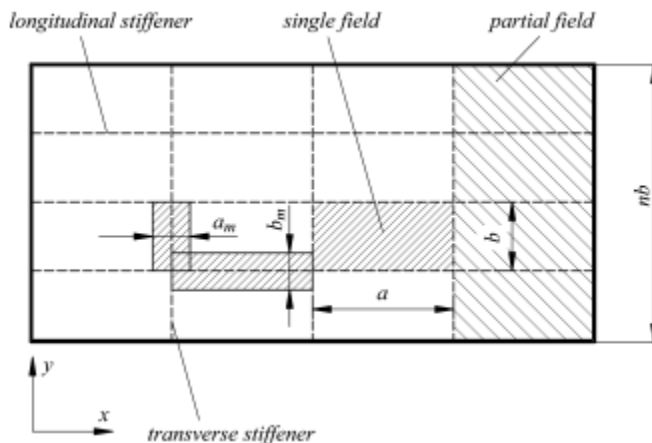

Fig. 7.10.6.24

Definitions in 7.10.6.24 ÷ 7.10.6.32:

a – length of the longer side of a single plate field, in mm (x -direction);

b – breadth of the shorter side of a single plate field, in mm (y -direction);

α – aspect ratio of single plate field $\alpha = a/b$;

n – number of single plate field breadths within the partial or total plate field;

t – net plate thickness, in mm;

σ_x – membrane stress, in N/mm^2 , in x -direction;

σ_y – membrane stress, in N/mm^2 , in y -direction;

τ – shear stress, in N/mm^2 , in the x - y plane;

E – modulus of elasticity, in N/mm^2 , of the material;

$E = 2,06 \cdot 10^5$, in N/mm^2 , for steel;

σ_F – minimum yield stress, in N/mm^2 of the material;

σ_e – reference stress, in N/mm^2 , taken equal to:

$\sigma_e = 0,6 E(t/b)^2$;

ψ – edge stress ratio taken equal to

$\psi = \sigma_1/\sigma_2$;

σ_1 – maximum compressive stress;

σ_2 – minimum compressive stress or tension stress

S – safety factor (based on net scantling approach), taken equal to:

$S = 1,25$ for hatch covers when subjected to the vertical weather design load according to 7.10.6.6;

$S = 1,10$ for hatch covers when subjected to loads according to 7.10.6.8 and 7.10.6.14;

λ – reference degree of slenderness, taken equal to:

$\lambda = (\sigma_F / K\sigma_c)^{0,5}$;

K – buckling factor according to 7.10.6.26.

Compressive and shear stresses shall be taken positive, tension stresses shall be taken negative.

If stresses in the x - and y -direction already contain the Poisson-effect (calculated using FEM), the following modified stress values may be used.

Both stresses σ_x^* and σ_y^* shall be compressive stresses, in order to apply the stress reduction according to the following formulae:

$$\sigma_x = (\sigma_x^* - 0,3\sigma_y^*)/0,91; \quad (7.10.6.24-1)$$

$$\sigma_y = (\sigma_y^* - 0,3\sigma_x^*)/0,91, \quad (7.10.6.24-2)$$

where:

σ_x^* , σ_y^* – stresses containing the Poisson-effect.

Where compressive stress fulfils the condition $\sigma_y^* < 0,3\sigma_x^*$, then $\sigma_y = 0$ and $\sigma_x = \sigma_x^*$.

Where compressive stress fulfils the condition $\sigma_x^* < 0,3\sigma_y^*$, then $\sigma_x = 0$ and $\sigma_y = \sigma_y^*$.

F_1 – correction factor for boundary condition at the longitudinal stiffeners according to Table 7.10.6.24.

Table 7.10.6.24 Correction factor F_1

	Correction factor F_1
Stiffeners sniped at both ends	1,00

Guidance values ¹ where both ends are effectively connected to adjacent structures	1,05 for flat bars 1,10 for bulb sections 1,20 for angle and tee-sections 1,30 for U-type sections ² and girders of high rigidity
¹ Exact values may be determined by direct calculations. ² Higher value may be taken if it is verified by a buckling strength check of the partial plate field using non-linear FEA and deemed appropriate by the individual classification society but not greater than 2,0.	

7.10.6.25 Proof shall be provided that the following condition is complied with for the single plate field ab:

$$\left(\frac{|\sigma_x|S}{k_x\sigma_F}\right)^{e1} + \left(\frac{|\sigma_y|S}{k_y\sigma_F}\right)^{e2} - B\left(\frac{\sigma_x\sigma_y S^2}{\sigma_F^2}\right) + \left(\frac{|\tau|S\sqrt{3}}{k_\tau\sigma_F}\right)^{e3} \leq 1,0. \tag{7.10.6.25}$$

The first two terms and the last term of the above condition shall not exceed 1,0.

The reduction factors k_x , k_y and k_τ , are given in Table 7.10.6.26.

Where $\sigma_x \leq 0$ ((tension stress), $k_x=1,0$;

Where $\sigma_y \leq 0$ ((tension stress), $k_y=1,0$.

The exponents e_1 , e_2 , e_3 , as well as the factor B shall be taken as given in Table 7.10.6.25.

Table 7.10.6.25. Coefficients e_1 , e_2 , e_3 and factor B

Exponents e_1 , e_2 , e_3 , and factor B	Plate panel
e_1	$1+k_x^4$
e_2	$1+k_y^4$
e_3	$1+k_x k_y k_\tau^2$
B σ_x and σ_y – positive (compression stress)	$(k_x k_y)^5$
B σ_x and σ_y – negative (tension stress)	1

7.10.6.26 Buckling and reduction factors for plane elementary plate panels are given in Table 7.10.6.26.

Table 7.10.6.26

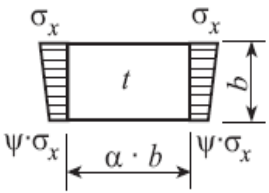
Buckling-load case	Edge stress ratio ² ψ	Factor ¹ $\alpha = a/b$	Buckling factor ³ K	Reduction factor k
1	2	3	4	5
	$1 \geq \psi \geq 0$	$\alpha \geq 1$	$K = 8,4/(\psi + 1,1)$	$k_x = 1$, for $\lambda \leq \lambda_c$ $k_x = c[(1/\lambda) - (0,22/\lambda^2)]$, for $\lambda > \lambda_c$ $c = (1,25 - 0,12\psi) \leq 1,25$ $\lambda_c = 0,5c\{1 + [1 - (0,88/c)]^{1/2}\}$
	$0 > \psi > -1$		$K = 7,63 - \psi(6,26 - 10\psi)$	
	$\psi \leq -1$		$K = 5,975(1 - \psi)^2$	

Continue of Table 7.10.6.26

Buckling-load case	Edge stress ratio ² ψ	Factor ¹ $\alpha = a/b$	Buckling factor ³ K	Reduction factor k
2	2	3	4	5
	$1 \geq \psi \geq 0$	$\alpha \geq 1$	$K = F_1 [1 + (1/\alpha^2)]^2 \times [2,1/(\psi + 1,1)]$	$k_y = c\{(1/\lambda) - \{[R + F^2(H - R)]/\lambda^2\}\}$ $c = (1,25 - 0,12\psi) \leq 1,25$ $R = \lambda[1 - (\lambda/c)]$, for $\lambda < \lambda_c$
	$0 > \psi > -1$	$1 \leq \alpha \leq 1,5$	$K = F_1 \{[1 + (1/\alpha^2)]^2 \times [2,1(1 + \psi)/1,1] - [(\psi/\alpha^2) \times (13,9 - 10\psi)]\}$	
			$K = F_1 \{[1 + (1/\alpha^2)]^2 \times$	

		$\alpha > 1,5$	$\times [2,1(1+\psi)/1,1] - (\psi/\alpha^2) \times [5,87 + 1,87\alpha^2 + (8,6/\alpha^2) - 10\psi]$	$R=0,22$, for $\lambda \geq \lambda_c$
	$\psi \leq -1$	$1 \leq \alpha \leq \leq 3(1-\psi)/4$	$K = F_1 [(1-\psi)/\alpha]^2 \times 5,975$	$\lambda_c = 0,5c \{1 + [1 - (0,88/c)]^{1/2}\}$ $F = (1 - \{(K/0,91) - 1\} / \lambda_p^2) \}$ $c_1 \geq 0$
		$\alpha > > 3(1-\psi)/4$	$K = F_1 \{ [(1-\psi)/\alpha]^2 \times 3,9675 + + 0,5375 [(1-\psi)/\alpha]^4 + 1,87 \}$	$\lambda_p^2 = \lambda^2 - 0,5$, for $1 \leq \lambda_p^2 \leq 3$; $c_1 = [1 - (F_1/\alpha)] \geq 0$; $H = \lambda - \{2 \lambda / \{c \times [T + (T^2 - 4)^{1/2}]\}$ $T = \lambda + (14/15\lambda) + (1/3)$
	$1 \geq \psi \geq 0$		$K = 4[0,425 + (1/\alpha^2)] / (3\psi + 1)$	$K_x = 1$, for $\lambda \leq 0,7$ $K_x = 1 / (\lambda^2 + 0,51)$, for $\lambda > 0,7$
	$0 > \psi > -1$	$\alpha > 0$	$K = 4[0,425 + (1/\alpha^2)] \times (1 + \psi) - -5\psi (1 - 3,42\psi)$	
	$1 \geq \psi \geq -1$	$\alpha > 0$	$K = [0,425 + (1/\alpha^2)] \times (3 - \psi) / 2$	
			$K = K_\tau \sqrt{3}$	$k_\tau = 1$, for $\lambda \leq 0,84$ $k_\tau = 0,84 / \lambda$, for $\lambda > 0,84$
		$\alpha \geq 1$	$K_\tau = (5,34 + 4/\alpha^2)$	
		$0 < \alpha < 1$	$K_\tau = (4 + 5,34/\alpha^2)$	
<p>Explanation for boundary conditions: ----- plate edge free _____ plate edge simply supported</p> <p>¹ Factor $\alpha = a/b$ – dimension ratio $\alpha = a/b$. ² Edge stress ratio considering unevenness of plate edge compression. ³ Buckling factor K depending on the plate loading and side ratio $\alpha = a/b$.</p>				

7.10.6.27 For non-stiffened webs and flanges of primary supporting members not supported by stiffeners, sufficient buckling strength as for the hatch cover top and lower plating shall be demonstrated according to **7.10.6.25**.

7.10.6.28 It shall be demonstrated that the continuous longitudinal and transverse stiffeners of partial and total plate fields comply with the conditions set out in **7.10.6.30** and **7.10.6.31**.

For U-type stiffeners, the proof of torsional buckling strength according to **7.10.6.31** can be omitted.

Single-side welding is not permitted to use for secondary stiffeners except for U-stiffeners.

7.10.6.29 For demonstration of buckling strength according to **7.10.6.30** and **7.10.6.31**, the effective width of plating may be determined by the following formulae:

$$b_m = k_x b \text{ – for longitudinal stiffeners;} \tag{7.10.6.29-1}$$

$$a_m = k_y a - \text{for transverse stiffeners;} \quad (7.10.6.29-2)$$

refer also to Fig. 7.10.6.24.

The effective width of plating shall not be taken greater than the value obtained from 7.10.6.22.

The effective width e'_m of stiffened flange plates of primary supporting members may be determined as follows:

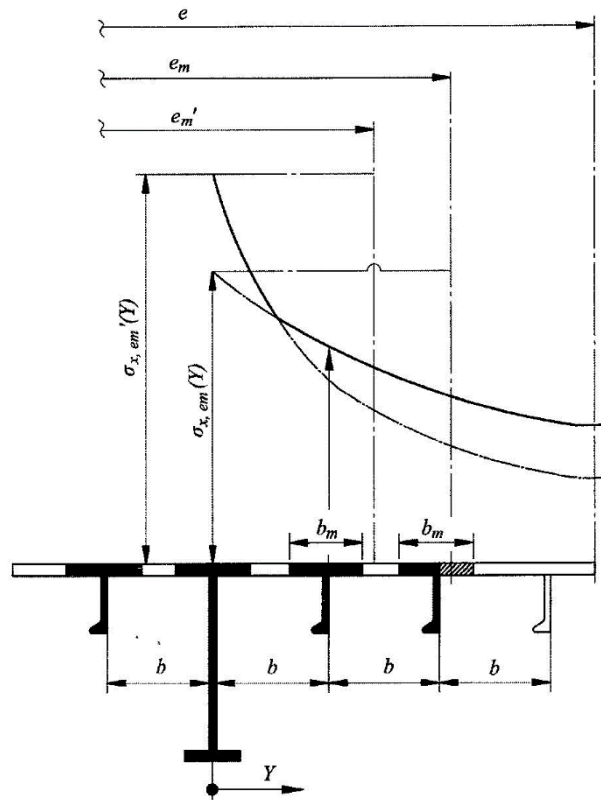

Fig. 7.10.6.29-1. Stiffening parallel to web of primary supporting member

$$b < e_m;$$

$$e'_m = nb_m;$$

n – integer number of stiffener spacings b inside the effective breadth e_m according to 7.10.6.22.

$$n = e'_m/b \text{ (is rounded to the nearest integer).}$$

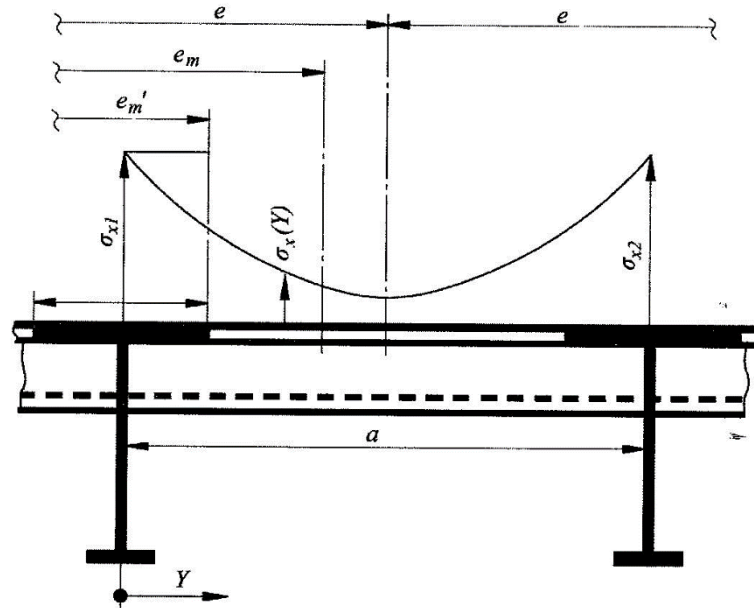

Fig. 7.10.6.29-2. Stiffening perpendicular to web of primary supporting member

$$a \geq e_m;$$

$$e'_m = na_m < e_m;$$

$$n = 2,7(e_m/a) \leq 1;$$

e – width of plating supported according to 7.10.6.22.

For $b \geq e_m$ or $a < e_m$, respectively, b and a shall be exchanged.

a_m and b_m for flange plates shall be in general determined for $\psi = 1$.

Note. Scantlings of plates and stiffeners shall be in general determined according to the maximum stresses $\sigma_x(y)$ at webs of primary supporting member and stiffeners, respectively.

For stiffeners with spacing b under compression arranged parallel to primary supporting members, no value less than $0,25\sigma_F$ shall be inserted for $\sigma_x(y = b)$.

The stress distribution between two primary supporting members can be obtained by the following formulae:

$$\sigma_x(y) = \sigma_{x1} \left\{ 1 - \frac{y}{e} [3 + c_1 - 4c_2 - 2\frac{y}{e} (1 + c_1 - 2c_2)] \right\};$$

$$c_1 = \sigma_{x2}/\sigma_{x1}; \quad 0 \leq c_1 \leq 1;$$

(7.10.6.29-3)

$$c_2 = \frac{1,5}{e} (e''_{m1} + e''_{m2}) - 0,5;$$

where:

e''_{m1} – proportionate effective breadth e_{m1} or proportionate effective width e'_{m1} of primary supporting member 1 within the distance e , as appropriate;

e''_{m2} – proportionate effective breadth e_{m2} or proportionate effective width e'_{m2} of primary supporting member 2 within the distance e , as appropriate;

σ_{x1}, σ_{x2} – normal stresses in flange plates of adjacent primary supporting member 1 and 2 with spacing e , based on cross-sectional properties considering the effective breadth (e_{m1}, e_{m2}) or effective width (e'_{m1}, e'_{m2}), as appropriate;

y – distance of considered location from primary supporting member 1.

Shear stress distribution in the flange plates may be assumed linearly.

7.10.6.30 Lateral buckling of secondary stiffeners shall be the following:

$$(\sigma_a + \sigma_b)(S/\sigma_F) \leq 1,$$

(7.10.6.30)

where: σ_a – uniformly distributed compressive stress, in N/mm^2 , in the direction of the stiffener axis;

$\sigma_a = \sigma_x$ – for longitudinal stiffeners;

$\sigma_a = \sigma_y$ – for transverse stiffeners;

σ_b – bending stress, in N/mm^2 , in the stiffener;

$\sigma_b = (M_0 + M_1)/Z \cdot 10^3$;

M_0 – bending moment, in N·mm, due to the deformation w of stiffener, taken equal to:

$$M_0 = F_{Ki} p_z w / (c_f - p_z), \text{ with } (c_f - p_z) > 0;$$

M_1 – bending moment, in N·mm, due to the lateral load p equal to:

$$M_1 = p b a^2 / (24 \cdot 10^3) \text{ – for longitudinal stiffeners;}$$

$$M_1 = p a (n b)^2 / (c_s \cdot 8 \cdot 10^3) \text{ – for transverse stiffeners;}$$

n shall be equal to 1 for ordinary transverse stiffeners;

p – lateral load, in N/mm²;

F_{Ki} – ideal buckling force, in N, of the stiffener;

$$F_{Kix} = (\pi^2 / a^2) E I_x \cdot 10^4 \text{ – for longitudinal stiffeners;}$$

$$F_{Kiy} = [\pi^2 / (n b)^2] E I_y \cdot 10^4 \text{ – for transverse stiffeners;}$$

I_x, I_y – net moments of inertia, in cm⁴, of the longitudinal or transverse stiffener, including effective width of attached plating according to 7.10.6.29. I_x and I_y shall comply with the following criteria:

$$I_x \geq b t^3 / (12 \cdot 10^4);$$

$$I_y \geq a t^3 / (12 \cdot 10^4);$$

p_z – nominal lateral load, in N/mm², of the stiffener due to σ_x, σ_y and σ_z ;

$$p_{zx} = (t/b) [\sigma_{x1} (\pi b/a)^2 + 2 c_y \sigma_y + \sqrt{2 \tau_1}] \text{ – for longitudinal stiffeners;}$$

$$p_{zy} = (t/a) [2 c_x \sigma_{x1} + \sigma_y (\pi a/n b)^2 \cdot (1 + A_y/a t) + \sqrt{2 \tau_1}] \text{ – for transverse stiffeners;}$$

$$\sigma_{x1} = \sigma_x [1 + (A_x/b t)];$$

c_x, c_y – factors taking into account the stresses perpendicular to the stiffener's axis and distributed variable along the stiffener's length;

$$c_x, c_y = 0,5(1 + \psi) \text{ for } 0 \leq \psi \leq 1;$$

$$c_x, c_y = 0,5/(1 - \psi) \text{ for } \psi < 0;$$

A_x, A_y – net sectional area, in mm², of the longitudinal or transverse stiffener, respectively, without attached plating;

$$\tau_1 = [\tau - t \sqrt{\sigma_F E (m_1/a^2 + m_2/b^2)}] \geq 0;$$

– for longitudinal stiffeners:

$$a/b \geq 2,0: m_1 = 1,47 \quad m_2 = 0,49;$$

$$a/b < 2,0: m_1 = 1,96 \quad m_2 = 0,37;$$

– for transverse stiffeners:

$$a/n b \geq 0,5: m_1 = 0,37 \quad m_2 = 1,96/n^2;$$

$$a/n b < 0,5: m_1 = 0,49 \quad m_2 = 1,47/n^2;$$

$$w = w_0 + w_1;$$

w_0 – assumed imperfection, in mm;

$$w_{0x} \leq \min(a/250, b/250, 10) \text{ – for longitudinal stiffeners;}$$

$$w_{0y} \leq \min(a/250, n b/250, 10) \text{ – for transverse stiffeners.}$$

Note. For stiffeners sniped at both ends w_0 shall not be taken less than the distance from the midpoint of plating to the neutral axis of the profile including effective width of plating.

w_1 – deformation of stiffener, in mm, at midpoint of stiffener span due to lateral (transverse) load p .

In case of uniformly distributed load the following values for w_1 may be used:

$$w_1 = p b a^4 / (384 \cdot 10^7 E I_x) \text{ – for longitudinal stiffeners;}$$

$$w_1 = 5 p a (n b)^4 / (384 \cdot 10^7 E I_y c_s^2) \text{ – for transverse stiffeners;}$$

c_f – elastic support provided by the stiffener, in N/mm²;

– for longitudinal stiffeners:

$$c_{fx} = F_{Kix} (\pi^2 / a^2) (1 + c_{px});$$

$$c_{px} = \frac{1}{0,91 \left(\frac{12 \times 10^4 I_x}{t^3 b} - 1 \right) + \frac{c_{xa}}{1}};$$

$$c_{xa} = [(a/2b) + (2b/a)]^2, \text{ for } a \geq 2b;$$

$$c_{xa} = [1 + (a/2b)^2]^2, \text{ for } a < 2b;$$

– for transverse stiffeners:

$$c_{fy} = c_s F_{Kiy} (1 + c_{py}) \pi^2 / (nb)^2;$$

$$c_{py} = \frac{1}{0,91 \left(\frac{12 \times 10^4 I_y}{t^3 a} - 1 \right) + \frac{c_{ya}}{1}};$$

$$c_{ya} = [(nb/2a) + (2a/nb)]^2, \text{ for } nb \geq 2a;$$

$$c_{ya} = [1 + (nb/2a)^2]^2, \text{ for } nb < 2a;$$

c_s – factor accounting for the boundary conditions of the transverse stiffener;

$c_s = 1,0$ – for simply supported stiffeners;

$c_s = 2,0$ – for partially constraint stiffeners;

z_{st} – net section modulus of stiffener (longitudinal or transverse), in cm^3 , including effective width of plating according to 7.10.6.29.

If no lateral load p is acting, the bending stress σ_b shall be calculated at the midpoint of the stiffener span for that fibre, which results in the largest stress value.

If a lateral load p is acting, the stress calculation shall be carried out for both fibres of the stiffener's cross sectional area (if necessary for the biaxial stress field at the plating side).

7.10.6.31 The longitudinal secondary stiffeners shall comply with the following criteria:

$$(\sigma_x S / k_T \sigma_F) \leq 1,0, \quad (7.10.6.31)$$

where: k_T – coefficient taken equal to

$$k_T = 1,0, \text{ for } \lambda_T \leq 0,2;$$

$$k_T = 1 / [\Phi + (\Phi^2 - \lambda_T^2)^{0,5}], \text{ for } \lambda_T > 0,2;$$

$$\Phi = 0,5 [1 + 0,21(\lambda_T - 0,2) + \lambda_T^2];$$

λ_T – reference degree of slenderness taken equal to;

$$\lambda_T = (\sigma_F / \sigma_{KIT})^{0,5};$$

$$\sigma_{KIT} = (E / I_P) [(\pi^2 I_\omega \cdot 10^2 / a^2) \varepsilon + 0,385 I_T], \text{H/MM}^2;$$

for I_P, I_T, I_ω – refer to Fig. 7.10.6.31 and Table 7.10.6.31.

I_P – net polar moment of inertia of the stiffener, in cm^4 , related to the point C;

I_T – net St. Venant's moment of inertia of the stiffener, in cm^4 ;

I_ω – net sectorial moment of inertia of the stiffener, in cm^6 , related to the point C;

ε – degree of fixation taken equal to:

$$\varepsilon = 1 + 10^{-3} \sqrt{\frac{a^4}{\frac{3}{4} \pi^4 I_\omega (b/t^3 + 4h_w/3t_w^3)}},$$

h_w – web height, in mm;

t_w – net web thickness, in mm;

b_f – flange breadth, in mm;

t_f – net flange thickness, in mm;

A_w – net web area equal to:

$$A_w = h_w t_w;$$

A_f – net flange area equal to:

$$A_f = b_f t_f;$$

$$e_f = h_w + t_f / 2, \text{ in mm.}$$

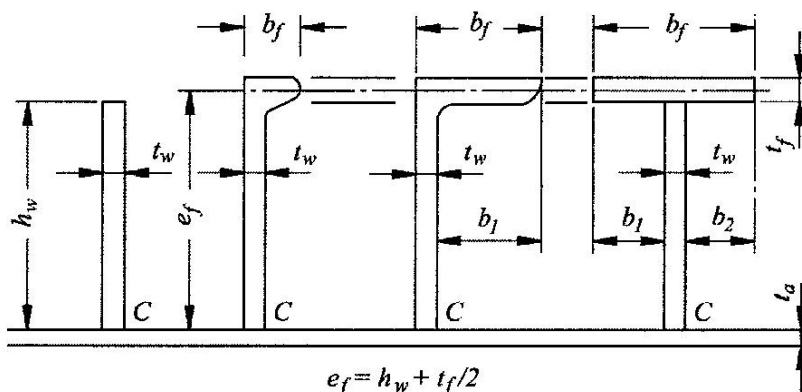

Fig. 7.10.6.31 Dimensions of stiffener

Table 7.10.6.31. Moments of inertia

Section	I_p	I_T	I_w
Flat bar	$(h_w^3 t_w)/(3 \times 10^4)$	$(h_w t_w^3)/(3 \times 10^4)[1-0,63(t_w/h_w)]$	$(h_w^3 t_w)/(36 \times 10^6)$
Sections with bulb or flange	$[(A_w h_w^2/3) + A_f e_f^2] 10^{-4}$	$(h_w t_w^3)/(3 \times 10^4)[1-0,63(t_w/h_w)] + (b_f t_f^3)/(3 \times 10^4)[1-0,63(t_f/b_f)]$	for bulb and angle sections: $\frac{A_f e_f^2 b_f^2}{12 \times 10^6} \left(\frac{A_f + 2,6 A_w}{A_f + A_w} \right)$ for tee-sections: $(t_f e^2 b^3)/(12 \times 10^6)$

7.10.6.32 or transverse secondary stiffeners loaded by compressive stresses, which are not supported by longitudinal stiffeners, sufficient torsional buckling strength shall be demonstrated according to 7.10.6.31.

7.10.6.33 Securing and arrangement of containers on the hatch covers shall comply with the technical requirements for the arrangement and securing of the international standard containers on board the ships intended for container transportation.

Structures under container load shall be calculated according to 7.10.6.5 ÷ 7.10.6.13 using the permissible stresses as per 7.10.6.14.

7.10.6.34 To ensure weather tightness, the provisions of IACS recommendation No. 14 applicable to hatch covers shall be met.

The packing material of hatch covers gaskets shall be suitable for all expected service conditions of the ship and shall be compatible with the cargoes to be transported.

The packing material shall be selected with regard to dimensions and elasticity in such a way that expected deformations can be carried. Forces shall be carried by the steel structure only.

The packings shall be compressed so as to give the necessary tightness effect for all expected operating conditions. Special consideration shall be given to the packing arrangement in ships with large relative movements between hatch covers and coamings or between hatch cover sections.

7.10.6.35 For hatch covers of cargo holds solely for the transport of containers, at the shipowner's request and subject to compliance with the following conditions, the fitting of weather tight gaskets mentioned in 7.10.6.34 may be dispensed with:

- the hatchway coamings shall be not less than 600 mm in height;
- the exposed deck, on which the hatch covers are located is situated above a depth $H(x)$,
- $H(x)$ shall be shown to comply with the following criteria:

$$H(x) \geq T_{fb} + f_b + h, \text{ m} \tag{7.10.6.35}$$

wher: T_{fb} – draught, in m, corresponding to the assigned summer load line;

f_b – minimum required freeboard, in m, determined in accordance with regulation, 27, 28 of the International Load Line Convention, as amended, where applicable;

$h = 4,6 \text{ m}$ for $x/L_{LL} \leq 0,75$;

$h = 6,9 \text{ m}$ for $x/L_{LL} > 0,75$.

Labyrinths, gutter bars or equivalents shall be fitted proximate to the edges of each panel in way of the coamings. The clear profile of these openings shall be kept as small as possible.

Where a hatch is covered by several hatch cover panels, the clear opening of the gap in between the panels shall be not wider than 50 mm.

The labyrinths and gaps between hatch cover panels shall be considered as unprotected openings with respect to the requirements of intact and damage stability calculations.

Bilge alarms shall be provided in each hold fitted with non-weathertight covers.

Furthermore, Chapter 3 of IMO circular MSC/Circ. 1087 shall be referred to concerning the stowage and segregation of containers containing dangerous goods.

7.10.6.36 Cross-joints of multi-panel covers shall be provided with efficient drainage arrangements.

7.10.6.37 The net thickness of weather deck hatch coamings shall not be less than that determined by the following formulae:

$$t = 14,2s(p_A/0,95\sigma_F)^{0,5}, \text{ in mm}; \quad (7.10.6.37-1)$$

$$t_{\min} = 6 + L_1/100, \text{ in mm}, \quad (7.10.6.37-2)$$

where: s – stiffener spacing, in m;

$L_1 = L$, need not be taken greater than 300 m.

Strength aspects of longitudinal hatch coamings shall meet the requirements of **1.6.5**, Part II "Hull".

7.10.6.38 The stiffeners shall be continuous at the coaming stays. For stiffeners with both ends constraint, the elastic net section modulus Z , in cm^3 , and net shear area A_s , in cm^2 , calculated on the basis of net thickness, shall not be less than:

$$Z = (83/\sigma_F) p_A s l^2; \quad (7.10.6.38-1)$$

$$A_s = (10/\sigma_F) p_A s l, \quad (7.10.6.38-2)$$

where:

s – secondary stiffener span, in m, to be taken as the spacing of coaming stays;

l – stiffener spacing, in m.

For sniped stiffeners at coaming corners section modulus and shear area at the fixed support shall be increased by 35 %.

The thickness of the coaming plate at the sniped stiffener end shall not be less than those defined as per the formula:

$$t = 19,6[(p_A s(l - 0,5s)/\sigma_F)^{0,5}], \text{ in mm} \quad (7.10.6.38-3)$$

Horizontal stiffeners on hatch coamings, which are part of the longitudinal hull structure, shall be designed according to the requirements in **1.6.5**, Part II "Hull".

7.10.6.39 Coaming stays shall be designed for the loads transmitted through them and permissible stresses according to **7.10.6.14**.

At the connection of the coaming stays with deck (refer to Figs. 7.1.6.39-1 and 7.1.6.39-2), the net section modulus Z , in cm^3 , shall be taken not less than:

$$Z = (526/\sigma_F) \cdot p_A \cdot e \cdot h_s^2, \text{ in cm} \quad (7.10.6.39)$$

where: e – spacing of coaming stays, in m;

h_s – height of coaming stays, in m.

For other designs of coaming stays, such as those shown in Figs. 7.10.6.39-3 and 7.10.6.39-4, the stresses shall be determined through a grillage analysis or FEM. The calculated stresses shall comply with the permissible stresses according to 7.10.6.14.

Coaming stays shall be supported by appropriate substructures. Face plates may only be included in the calculation if an appropriate substructure is provided and welding provides an adequate joint

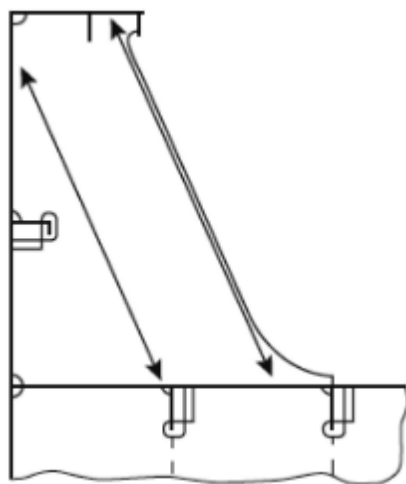

Fig. 7.10.6.39-1

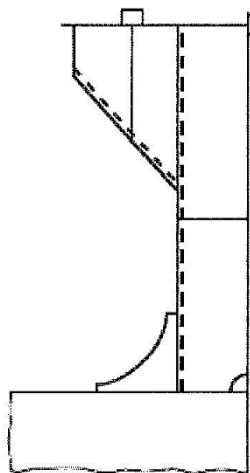

Fig. 7.10.6.39-2

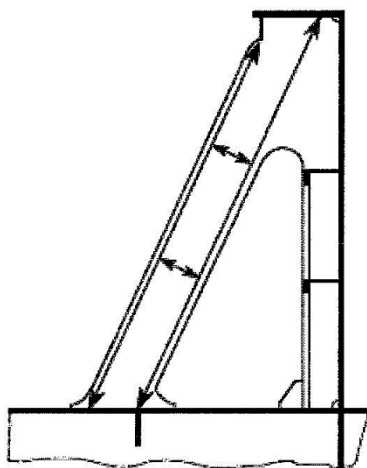

Fig. 7.10.6.39-3

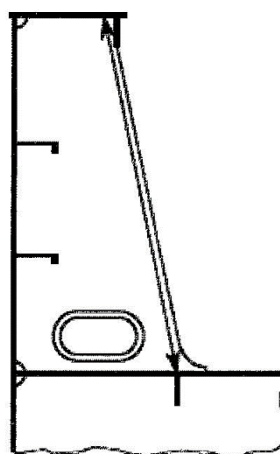

Fig. 7.10.6.39-4

7.10.6.40 Web gross thickness t_w , at the root point shall not be less than

$$t_w = (2/\sigma_F)(p_A e h_s / h_w) + t_s, \tag{7.10.6.40}$$

where: h_w – web height of coaming stay at its lower end, in m;
 t_s – corrosion addition, in mm, according to 7.10.6.52.

Coaming stays shall be connected to the deck by fillet welds on both sides with a throat thickness of $a = 0,44 t_w$.

7.10.6.41 Hatch coamings which are part of the longitudinal hull structure shall be designed according to the requirements of 1.6.5, Part II "Hull".

Longitudinal hatch coamings with a length exceeding $0,1L$ shall be provided with tapered brackets or equivalent transitions and a corresponding substructure at both ends.

At the end of the brackets they shall be connected to the deck by full penetration welds of minimum 300 mm in length.

7.10.6.42 Hatch coamings and supporting structures shall be adequately stiffened to accommodate the loading from hatch covers, in longitudinal, transverse and vertical directions. Structures under deck shall be checked against the load transmitted by the stays.

Structures under deck shall be checked against the load transmitted by the stays.

Unless otherwise stated, weld connections shall be dimensioned according to 1.7, Part II "Hull" and materials shall be selected according to 2.2, Part XIV "Welding".

7.10.6.43 On ships carrying cargo on deck, such as timber, coal or coke, the stays shall be spaced not more than 1,5 m apart.

Coaming plates shall extend to the lower edge of the deck beams or hatch side girders shall be fitted that extend to the lower edge of the deck beams. Extended coaming plates and hatch side girders shall be flanged or fitted with face bars or half-round bars. Fig. 7.10.6.43 gives an example.

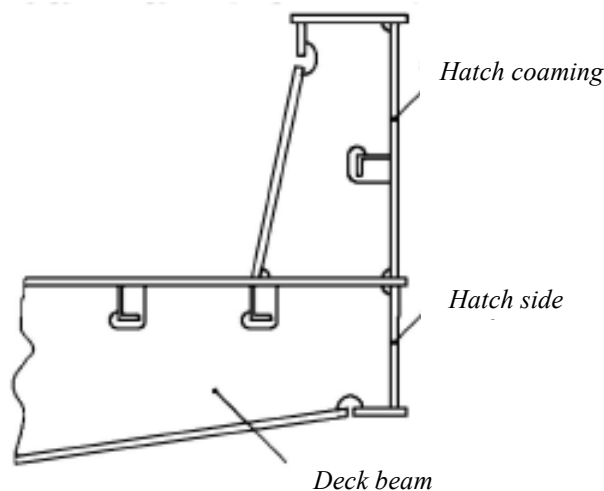

Fig. 7.10.6.43

7.10.6.44 If drain channels are provided inside the line of gasket by means of a gutter bar or vertical extension of the hatch side and end coaming, drain openings shall be provided at appropriate positions of the drain channels.

Drain openings in hatch coamings shall be arranged with sufficient distance to areas of stress concentration (e.g. hatch corners, transitions to crane posts).

Drain openings shall be arranged at the ends of drain channels and shall be provided with non-return valves to prevent ingress of water from outside. It is unacceptable to connect fire hoses to the drain openings for this purpose.

If a continuous outer steel contact between cover and ship structure is arranged, drainage from the space between the steel contact and the gasket shall be also provided.

7.10.6.45 Securing devices between cover and coaming and at cross-joints shall be installed to provide weathertightness.

Securing devices shall be appropriate to bridge displacements between cover and coaming due to hull deformations. These devices shall be of reliable construction and effectively attached to the hatchway coamings, decks or covers. Individual securing devices on each cover shall have approximately the same stiffness characteristics.

Sufficient number of securing devices shall be provided at each side of the hatch cover considering the requirements of **7.10.6.20**; this applies also to hatch covers consisting of several parts.

7.10.6.46 Where rod cleats are fitted, resilient washers or cushions shall be incorporated.

Where hydraulic cleating is adopted, positive means shall be provided so that it remains mechanically locked in the closed position in the event of failure of the hydraulic system.

7.10.6.47 The gross sectional area, in cm^2 , shall not be less than that defined by the formula

$$A = 0,28q_{SD}k_l, \quad (7.10.6.47)$$

where: q – packing line pressure, in N/mm , minimum 5 N/mm ;

s_{SD} – spacing between securing devices, in m , but not less than 2 m ;

$k_l = (235/\sigma_F)^e$;

σ_F – minimum yield strength of the material, in N/mm^2 , but not greater than $0,7\sigma_m$, where σ_m – is the tensile strength of the material, in N/mm^2 ;

$e = 0,75$ for $\sigma_F > 235 \text{ N/mm}^2$;

$e = 1,00$ for $\sigma_F \leq 235 \text{ N/mm}^2$.

For hatchways exceeding 5 m^2 , rods and bolts shall have a gross diameter no less than 19 mm .

Securing devices of special design in which significant bending or shear stresses occur may be designed as anti-lifting devices according to **7.10.6.48**.

As load the packing line pressure q multiplied by the spacing between securing devices s_{SD} shall be applied.

7.10.6.48 The securing devices of hatch covers, on which cargo is lashed, shall be designed for the lifting forces resulting from loads according to **7.10.6.11** ÷ **7.10.6.13**, refer to Fig. 7.10.6.48.

Unsymmetrical loadings, which may occur in practice, shall be considered. Under these loadings the equivalent stress in the securing devices shall not exceed

$$\sigma_V = 150/k_l, \text{ N/mm}^2 \quad (7.10.6.48)$$

Note. The partial load cases given in Table 7.10.6.12 may not cover all unsymmetrical loadings, critical for hatch cover lifting.

Chapter 5.6 of IACS Recommendation No. 14 shall be referred to for the omission of anti-lifting devices.

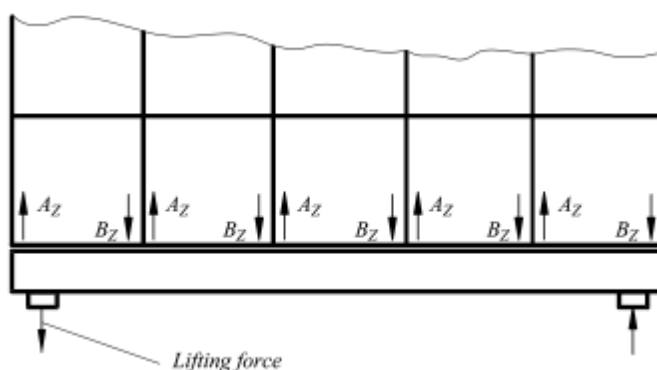

Fig. 7.10.6.48. Lifting forces at a hatch cover

7.10.6.49 For the design of the hatch cover supports, the horizontal mass forces $F_h = ma$ shall be calculated with the following accelerations:

$a_x = 0,2g$ in longitudinal direction;

$a_y = 0,2g$ in transverse direction;

m – sum of mass of cargo lashed on the hatch cover and mass of hatch cover.

The accelerations in longitudinal direction and in transverse direction do not need to be considered as acting simultaneously.

7.10.6.50 For the transmission of the support forces resulting from the load cases specified in **7.10.6.5** ÷ **7.10.6.13**, and of the horizontal mass forces specified in **7.10.6.49**, supports shall be provided which shall be designed such that the nominal surface pressures in general do not exceed the following values:

$$p_{n\max} = dp_n, \text{ N/mm}^2, \quad (7.10.6.50-1)$$

where: $d = 3,75 - 0,015L$;

$d_{\max} = 3,0$;

$d_{\min} = 1,0$ in general;

$d_{\min} = 2,0$ for partial loading conditions, refer to **7.10.6.12**;

p_n – refer to Table 7.10.6.50.

Table 7.10.6.50 . Permissible nominal surface pressure p_n

Support material	p_n , in N/mm ² , when loaded by	
	vertical force	horizontal force (on stoppers)
Hull structural steel	25	40
Hardened steel	35	50
Lower friction materials	50	–

For metallic supporting surfaces not subjected to relative displacements, the nominal surface pressure shall be calculated by the formula:

$$p_{n\max} = 3p_n, \text{ N/mm}^2. \quad (7.10.6.50-2)$$

Where large relative displacements of the supporting surfaces are expected, the use of material having low wear and frictional properties is recommended.

The substructures of the supports shall be of such a design, that a uniform pressure distribution is achieved.

Irrespective of the arrangement of stoppers, the supports shall be able to transmit the following force P_h in the longitudinal and transverse directions:

$$P_h = \mu P_v / \sqrt{d}. \quad (7.10.6.50-3)$$

where: P_v – vertical supporting force;

μ – frictional coefficient, in general equal to 0,5.

For non-metallic, low-friction support materials on steel, the friction coefficient may be reduced but not to be less than 0,35.

Supports as well as the adjacent structures and substructures shall be designed such that the permissible stresses according to **7.10.6.14** are not exceeded.

7.10.6.51 Hatch covers shall be sufficiently secured against horizontal shifting. Stoppers shall be provided for hatch covers, on which cargo is carried.

The greater of the loads resulting from **7.10.6.8** and **7.10.6.49** shall be applied for the dimensioning of the stoppers and their substructures.

The permissible stress in stoppers, their substructures, in the cover, and of the coamings shall be determined according to **7.10.6.14**; in addition, the provisions in **7.10.6.50** shall be observed.

7.10.6.52 Corrosion additions (corrosion allowance) t_s , in mm, for hatch covers and hatch coamings are given in Table **7.10.6.52**.

Table 7.10.6.52. Corrosion addition t_s , for hatch covers and hatch coamings

Application	Structure	t_s , in mm,
	Hatch covers	1,0

Weather deck hatches of container ships, car carriers, paper carriers, passenger vessels	Hatch coamings	According to 1.1.5.1 , Part II "Hull"
Weather deck hatches of all other ship types	Hatch covers in general	2,0
	Weather exposed plating and bottom plating of double skin hatch covers	1,5
	Internal structure of double skin hatch covers and closed box girders (hollow beams)	1,0
	Hatch coamings not part of the longitudinal hull structures	1,5
	Hatch coamings part of the longitudinal hull structures	According to 1.1.5.1 , Part II "Hull"
	Coaming stays and stiffeners	1,5

7.10.6.53 Steel renewal is required where the gauged thickness is less than $t_{net} + 0,5$ mm for:
single skin hatch covers;
the plating of double skin hatch covers, and
coaming structures the corrosion additions t_s of which are provided in Table 7.10.6.52.

Where the gauged thickness is within the range $t_{net} + 0,5$ mm to $t_{net} + 1,0$ mm, coating (applied in accordance with the coating manufacturer's requirements) or annual gauging may be adopted as an alternative to steel renewal. Coating shall be maintained in GOOD condition, as defined in 1.2, IACS UR Z10.2 (Rev.36 May 2019).

For the internal structure of double skin hatch covers, thickness gauging is required when hatch cover top or bottom plating renewal shall be carried out or when this is deemed necessary, at the discretion of the surveyor to the Register, on the basis of the plating corrosion or deformation condition. In these cases, steel renewal for the internal structures is required where the gauged thickness is less than t_{net} .

For corrosion addition $t_s = 1,0$ mm, the thickness for steel renewal is t_{net} , and the thickness for coating or annual gauging is when gauged thickness is between t_{net} and $t_{net} + 0,5$ mm.

For coaming structures, the corrosion additions t_s of which are not provided in Table 7.10.6.52 shall be in compliance with the requirements of **1.1.5** Part II "Hull".

7.11 HATCHWAYS OF CARGO TANKS IN TYPE "A" SHIPS, OIL TANKERS, OIL TANKERS (>60°C), OIL RECOVERY SHIPS AND OIL RECOVERY SHIPS (>60°C)

7.11.1 Height of the coamings of cargo tank hatchways intended for the carriage liquid cargoes is not regulated by the Register. Construction of the coamings of cargo tank hatchways shall comply with the requirements of **3.5.5.1**, Part II "Hull".

7.11.2 Covers of hatches and tank cleaning openings shall be made of steel, bronze or brass.

7.11.3 Covers of the cargo tank hatchways shall be permanently attached or fixed with closely spaced bolts and tight, when secured, under the inner pressure of liquid carried in tanks to a head of not less than 2,5 m. Tightness shall be provided by a rubber or other suitable gasket being resistant to the liquids which are carried in the cargo tanks.

7.12 OPENINGS IN WATERTIGHT SUBDIVISION BULKHEADS AND THEIR CLOSING APPLIANCES

7.12.1 General.

7.12.1.1 Unless expressly provided otherwise, this Chapter covers ships to which the requirements of Part V "Subdivision" apply.

For other ships, the requirements of this Chapter apply to bulkheads which installation is covered by **2.7.1.3** of Part II "Hull"; for these ships, the requirements may be relaxed provided the analysis confirming safety of the ship has been submitted.

In ships indicated in **7.12.6.1**, the requirements of **7.12.2** ÷ **7.12.5** may be relaxed for doors fitted in

watertight subdivision bulkheads dividing a cargo space from an adjoining cargo space provided the requirements of 7.12.6 are met.

7.12.1.2 The number of openings in watertight bulkheads shall be reduced to a minimum compatible with the design and normal service conditions of the ship.

7.12.1.3 Where piping and electric cables are carried through watertight subdivision bulkheads, the requirements of 5.1, Part VIII "Systems and Piping" and of 16.8.6, Part XI "Electrical Equipment" shall be taken into consideration.

7.12.2 Doors in watertight subdivision bulkheads. General.

7.12.2.1 The doors shall be made of steel. The use of other materials may be allowed provided it is confirmed by calculations and tests that they have a strength at least equivalent to that of the doors made of steel.

7.12.2.2 Doors shall withstand the pressure of a water head of the height measured from the lower edge of a doorway at the place of its location to the underside of bulkhead deck plating, the freeboard or the most adverse damage waterline, whichever is greater.

7.12.2.3 Under the effect of water head specified in 7.12.2.2, the stresses in the door frame and door plate shall not exceed 0,6 times the upper yield stress of their material.

7.12.2.4 When closed, the doors shall be tight under the pressure of a water head of the height specified in 7.12.2.2.

7.12.2.5 Each means of operation of the doors shall alone ensure closure of the door with the ship listed 15° either way and with a trim up to 5°.

Doors closed by dropping or by the effect of a dropping weight are not permitted. Portable plates secured by bolts only are not permitted.

7.12.3 Regulations concerning the positioning of doors.

7.12.3.1 No doors are permitted in:

collision bulkhead below the bulkhead deck of ships having a subdivision distinguishing mark in the class notation and below the freeboard deck of all other ships;

watertight subdivision bulkheads dividing a cargo space from an adjoining cargo space except where the Register is satisfied that such doors are essential. In this case, the doors may be hinged, sliding or of another equivalent type, but they shall not be remotely controlled.

In passenger ships and special purpose ships, as well as in ships with subdivision distinguishing mark in the class notation, the outboard vertical edges of the doors shall not be located at less than 0,2 of the ship breadth. This distance shall be measured at right angles to the centreline of the ship at the level of the deepest subdivision loadline.

7.12.3.2 In addition to doors at entrances to propeller shaft tunnels, not more than one door may be provided in each watertight subdivision bulkhead within spaces containing main engines, boilers and auxiliary machinery.

Where two or more propeller shafts are fitted, their tunnels shall be connected by a passageway. In a twinscrew ship, there shall only be one door between the engine room and tunnel spaces, and if the propellers are more than two, only two doors shall be provided. All the doors shall be located as high as practicable.

Hand gear for operating the doors from above the bulkhead deck and for operating doors at entrances to shaft tunnels shall be fitted outside the engine room.

7.12.4 Doors in cargo ships.

7.12.4.1 The requirements of 7.12.4 apply to doors fitted in the subdivision bulkheads of cargo ships except the doors of special purpose ships and those mentioned under 7.12.6.

7.12.4.2 The doors shall be sliding doors with horizontal or vertical motion, they shall be both hand and power-operated.

If hand-operated, it shall be possible to open and close the door from both sides of the bulkhead.

If power-operated, closing of the doors from the control station on the navigation bridge shall be possible.

7.12.4.3 At the door control stations, visual indicators shall be provided to show whether the doors are open or closed. An alarm shall be provided to control the door closing.

Power source, control station and indicators shall be operable in the case of main power source failure. Special attention shall be paid to minimizing the effects of the control system failure.

7.12.5 Doors in passenger ships and special purpose ships.

7.12.5.1 The requirements of 7.12.5 apply to doors fitted in the subdivision bulkheads of passenger ships and special purpose ships except those mentioned in 7.12.6.

7.12.5.2 The doors shall be sliding doors with horizontal or vertical motion, they shall be both hand and power-operated.

The maximum width of the door aperture shall not exceed 1,2 m. Installation of doors with the aperture width in excess of 1,2 m shall be substantiated by calculations confirming their equivalent strength to the bulkhead in which they are fitted.

7.12.5.3 If the door is hand-operated, it shall be possible to manually open and close the door from both sides in the close proximity of the door and, in addition, close the door from an assessable place above the bulkhead deck by means of a hand wheel, handle or any other similar gear ensuring the same degree of safety. The force applied to the hand wheel, knob or similar gear while the door is in motion shall not exceed 157 N.

If the door is not visible from the position above the bulkhead deck where the gear is fitted, indicators shall be provided showing the positions of the hand wheel, knob and similar gear at which the door is open or closed.

When hand-operated, the time necessary for a complete closure of the door shall not exceed 90 s with the ship upright.

7.12.5.4 Door control knobs shall be fitted on either side of the bulkhead at a minimum height of 1,6 m above deck plating and so arranged as to enable persons passing through the doorway to hold both the knobs in a position preventing door closure.

The direction of movement of the handles in opening and closing the door shall be in the direction of door movement and shall be clearly indicated.

7.12.5.5 The power gear shall be controllable (i.e. door opening and closing shall be possible) by local control stations on either side of the bulkhead.

Besides being controlled directly at the door, the power gear shall also be controllable (for door closure) from the main control station.

Remote opening of any door from the main control station shall not be possible.

The main control station for doors shall be located in the wheelhouse.

7.12.5.6 The power gear shall ensure door closure in not more than 40 s and not less than 20 s with the ship upright, as well as a simultaneous closure of all doors within not more than 60 s.

7.12.5.7 The power gear of the doors shall have either:

.1 a centralized hydraulic system with two independent power sources each consisting of a motor and pump capable of simultaneously closing all doors.

In addition, there shall be for the whole installation hydraulic accumulators of sufficient capacity to operate all the doors at least three times, i.e. closed - open - closed at unfavourable conditions of heel up to 15°; or

.2 an independent hydraulic system for each door with each power source consisting of a motor and pump capable of opening and closing the door. In addition, there shall be a hydraulic accumulator of sufficient capacity to operate the door at least three times, i.e. closed - open - closed at unfavourable conditions of heel up to 15°; or

.3 an independent electrical system and motor for each door with each power source consisting of a motor capable of opening and closing the door. The power source shall be capable of being automatically supplied by a transitional emergency source of electrical power, as required by **19.1.2.7**, Part XI "Electrical Equipment" in the event of failure of either the main or emergency source of electrical power and with sufficient capacity to operate the door at least three times, i.e. closed - open - closed at unfavourable conditions of heel up to 15°.

7.12.5.8 Door controls, including hydraulic piping and electric cables, shall be kept as close as practicable to the bulkhead in which the doors are fitted, in order to minimize the likelihood of them being involved in any damage which the ship may sustain.

7.12.5.9 Each door shall be provided with an audible alarm, distinct from any other alarm in the area, which will sound whenever the door is closed remotely by power and which shall sound for at least five seconds, but not more than ten seconds, before the door begins to move, and shall continue sounding until the door is completely closed. In the case of remote hand operation it is sufficient for the audible alarm to sound only when the door is moving.

In passenger areas and areas of high ambient noise the Register may require the audible alarm to be supplemented by an intermittent visual signal at the door.

7.12.5.10 The central operating console at the navigation bridge shall have a switch with two modes of control:

a "local control" mode which shall allow any door to be locally opened and closed without automatic closure and

a "doors closed" mode which shall allow doors to be opened locally and shall automatically reclose the doors upon release of the local control mechanism.

The switch shall normally be in the "local control" position. The "doors closed" position shall only be used in an emergency or for testing purposes.

7.12.5.11 The central operating console at the navigation bridge shall be provided with a diagram showing the location of each door, with visual indicators to show whether each door is open or closed. A red light shall indicate a door fully open and a green light shall indicate a door fully closed. When a door is closed remotely, the red light shall indicate the intermediate position by flashing. The indicating circuit shall be independent of the control circuit for each door.

It shall not be possible to remotely open any door from the central operating console.

7.12.5.12 Where trunkways or tunnels for access from crew accommodation to the stokehold, for piping, or for any other purpose are carried through main transverse watertight bulkheads, they shall be watertight. The access to at least one end of each such tunnel or trunkway, if used as a passage at sea, shall be through a trunk extending watertight to a height sufficient to permit access above the margin line. The access to the other end of the trunkway or tunnel may be through a watertight door of the type required by its location in the ship. Such trunkways or tunnels shall not extend through first subdivision bulkhead abaft the collision bulkhead.

7.12.5.13 Where ventilating trunks in connection with refrigerated cargo and ventilation or forced draught trunks are carried through more than one watertight bulkhead, the means of closure at such openings shall be operated by power and be capable of being closed from the main control station situated above the bulkhead deck.

7.12.5.14 If the Register is satisfied that such doors are essential, watertight doors of satisfactory construction may be fitted in watertight bulkheads dividing cargo between deck spaces. Such doors may be hinged, rolling or sliding doors but shall not be remotely controlled. They shall be fitted at the highest level and as far from the shell plating as practicable, but in no case shall the outboard vertical edges be situated at a distance from the shell plating which is less than 0,2 of the breadth of the ship, as defined in **7.12.3.1**.

If any of such doors shall be accessible during the voyage, they shall be fitted with a device, which prevents unauthorized opening.

7.12.5.15 Portable plates on bulkheads shall not be permitted except in machinery spaces. The Register may permit not more than one power-operated sliding watertight door in each watertight bulkhead larger than those specified in **7.12.5.2** to be substituted for these portable plates, provided these doors are intended to remain closed during navigation except in case of urgent necessity at the discretion of master. These doors need not meet the requirements of **7.12.5.3** regarding complete closure by handoperated gear in 90 s.

7.12.5.16 For passenger ships and special purpose ships carrying more than 60 persons having length of 120 m or more or having three or more main vertical zones, the power operated doors shall comply with the requirements of **2.2.6.8**, Part VI "Fire Protection" (refer also to **2.2.6.7.3** of the above Part).

7.12.5.17 Plates with instructions on doors operation are to be provided on both sides of the door. Plates with text or pictures that warning of the danger of remaining in the doorway when the doors begin to close.

These plates are to be of reliable material and properly secured. The text of the instruction or warning plate shall include information about the closing of these doors.

7.12.5.18 In passenger ships of restricted areas of navigation **B-R3-S**, **B-R3-RS**, **C-R3-S**, **C-R3-RS** and **D-R3-S**, **D-R3-RS**:

.1 with length less than 24 m slide doors may be only with manual drive or both with manual and mechanical drive;

with length 24 m and over, where the total number of watertight doors does not exceed two and these doors are located in the engine room or in bulkheads separating this room, only doors with manual drive are allowed.

If sliding doors with a manual drive are installed, such doors are to be closed before the beginning of the voyage with passengers on board, and remain closed during the whole voyage;

.2 with length less than 24 m watertight doors that do not comply with the requirements of **7.12.2.5**, **7.12.5.2** and **7.12.5.18.1** may be installed provided that they are to be closed before the the voyage and remain closed during the whole voyage; The time of such doors opening in the port and closing before leaving the port is to be entered in the logbook;

7.12.6 Doors in ships designed for the carriage of vehicles.

7.12.6.1 The requirements of **7.12.6** apply to doors fitted in watertight subdivision bulkheads separating a cargo space from an adjacent cargo space in ships designed for the carriage of vehicles and covered by the requirements of Part V "Subdivision", if the total number of persons on board (excluding the master and the members of the crew or other persons employed or engaged in any capacity on board a ship on the business of that ship, and also a child under one year of age) is not greater than the value N determined by the formula

$$N = 12 + 0,04A,$$

(7.12.6.1)

where: A – total deck area, in m^2 , of spaces available for the stowage of vehicles where the clear height at the stowage position and at the entrances to such spaces is not less than 4 m.

7.12.6.2 The doors specified in 7.12.6.1 may be fitted at any level if the Register is satisfied that such doors are essential for the movement of the vehicles in the ship.

7.12.6.3 The doors specified in 7.12.6.1 shall be fitted as far from the shell plating as practicable, but in no case shall the outboard vertical edge of the door be situated at a distance from the shell plating that is less than 0,2 of the breadth of the ship, such distance being measured at right angles to the centreline of the ship at the level of the subdivision loadline.

7.12.6.4 The doors specified in 7.12.6.1 may be of the following types: hinged, sliding or rolling but they shall not be controlled remotely.

The doors shall be fitted with devices ensuring watertightness, securing and locking. When the sealing material of the door is not classed as non-combustible (refer to 1.6.3.1, Part VI "Fire Protection"), the gasket shall be suitably protected from the effects of fire by a method approved by the Register.

The doors shall be fitted with a device which prevents unauthorized opening.

7.12.6.5 The doors specified in 7.12.6.1 shall be so designed that they could be opened and closed both in case of unloaded and loaded decks, the deck deflections under the effect of the stowed cargo being taken into account.

The securing devices of the door shall be so designed that account is taken of the deck deflections under the effect of the stowed cargo resulting in relative displacement of the structural elements of the bulkhead and the door.

7.12.6.6 Where watertightness is ensured by rubber or other suitable gaskets and securing devices, at each corner of the door or door section (if any) the securing devices shall be fitted.

The securing devices of such doors shall be designed to withstand the following forces, in kN:

F_1 – for securing devices fitted at the lower edge of the door;

F_2 – for securing devices fitted at the upper edge of the door;

F_3 – for securing devices fitted at the vertical edge of the door.

These forces shall be determined by the formulae

$$F_1 = \frac{9,81A}{n_1} \left(\frac{H_1}{2} - \frac{h}{6} \right) + 29,42; \quad (7.12.6.6-1)$$

$$F_2 = \frac{9,81A}{n_2} \left(\frac{H_1}{2} - \frac{h}{3} \right) + 29,42; \quad (7.12.6.6-2)$$

$$F_3 = \frac{a}{A} [F_1(n_1 - 1)h_i + F_2(n_2 - 1)(h - h_i)], \quad (7.12.6.6-3)$$

where: A – clear area of the door, in m^2 ,

H_1 – vertical distance from the lower edge of the door opening to the lower edge of the plating of the bulkhead deck at the centreline of the ship, in m, but not less than 5 m;

h – clear height of the door, in m;

h_i – vertical distance from the securing device considered to the upper edge of the door, in m;

a – half the sum of the vertical distances from the securing device considered to the nearest upper and lower securing devices, in m;

n_1 – number of the securing devices fitted on the lower edge of the door;

n_2 – number of the securing devices fitted on the upper edge of the door.

When the securing device is under the effect of the design force F_1 , F_2 or F_3 the stresses in its parts shall not exceed 0,5 times the upper yield stress of material.

7.12.6.7 The operation of the doors specified in 7.12.6.1 shall be by means of local control only. On the bridge indicators shall be provided to show automatically that each door is closed and all door fastenings are secured.

7.12.6.8 The requirements of 7.12.2.2 ÷ 7.12.2.4 are also applicable to doors specified under 7.12.6.1.

7.12.7 Manholes in watertight subdivision bulkheads.

7.12.7.1 The requirements of 7.9 relating to the manholes located on the freeboard deck, raised quarter deck or the first tier of superstructures are generally applicable to the manholes fitted in the watertight subdivision bulkheads.

No manholes are permitted:

.1 in the collision bulkhead below the bulkhead deck for ships having subdivision distinguishing mark in the class notation, and below the freeboard deck for other ships;

.2 in watertight subdivision bulkheads separating a cargo space from an adjacent cargo space or a fuel oil tank.

7.13 CARGO HATCH COVERS OF BULK CARRIERS, ORE CARRIERS AND COMBINATION CARRIERS

7.13.1 The design of cargo hatch covers for bulk carriers, ore carriers and combination carriers shall comply with the requirements in 7.10.1, 7.10.2, 7.10.3.4, 7.10.3.5 and 7.10.4.

For bulk carriers of 90 m in length and above, contracted for construction on or after 1 July 2015, the requirements for cargo hatch covers are regulated by IACS Common Structural Rules for Bulk Carriers and Oil Tankers.

7.13.2 Cargo hatch covers shall be made of steel. The use of other materials may be allowed provided it is confirmed by calculations and tests that they have a strength at least equivalent to that of the hatch covers made of steel.

7.13.3 The pressure P , in kPa, on the hatch cover panels located on the freeboard deck is determined by the formulae:

for ships of 100 m in length and above

$$P = 34,3 + \frac{P_{FP} - 34,3}{0,25} \left(0,25 - \frac{X}{L} \right) \geq 34,3 \quad (7.13.3-1)$$

where: P_{FP} – pressure at the fore perpendicular to be determined by the formula

$$P_{FP} = 49,1 + (L-100)a ;$$

$a = 0,0726$ – for type "B" freeboard ships;

$a = 0,356$ – for ships with reduced freeboard;

L – ship's length, but not more than 340 m;

X – distance, in m, of the midlength of the hatch cover under consideration from the forward end of L .

Where a position 1 hatchway is located at least one superstructure standard height higher than the freeboard deck, the pressure P may be taken equal to 34,3 kPa;

for ships less than 100 m in length

$$P = 15,8 + \frac{L}{3} \left(1 - \frac{5X}{3L} \right) \geq 0,195L + 14,9, \quad (7.13.3-2)$$

Where two or more panels are connected by hinges, each individual panel shall be considered separately.

7.13.4 The normal σ_a and shear τ_a stresses in the hatch cover structures shall not exceed the permissible values:

$$\sigma_a = 0,8 R_{eH} ;$$

$$\tau_a = 0,46 R_{eH} ;$$

where: R_{eH} – upper yield stress of the hatch cover material.

The normal stressing compression of the attached flange of primary supporting members shall not exceed 0,8 times the critical buckling stress of the structure according to the calculations given in 7.13.9 ÷ 7.13.11.

The stresses in hatch covers that are designed as a grillage of longitudinal and transverse primary supporting members shall be determined by a grillage or a finite element analysis.

When a beam or a grillage analysis is used, the secondary stiffeners shall not be included in the attached flange area of the primary members.

When calculating the stresses σ and τ the net scantlings (no allowance for corrosion and wear) of hatch cover structure elements shall be used.

7.13.5 The effective flange area A_F , in cm^2 , of the attached plating, to be considered for the yielding and buckling checks of primary supporting members or grillages, is obtained as the sum of the effective flange areas of each side of the girder web:

$$A_F = \sum_{nf} (10b_{ef}t) \quad (7.13.5)$$

where: $nf = 2$ if attached plate flange extends on both sides of a girder web;

$nf = 1 - 1$ if attached plate flange extends on one side of a girder web only;

t – thickness of attached plate, in mm;

b_{ef} – effective breadth, in m, of attached plate flange on each side of a girder web assumed equal to b_p , but not more than $0,165l$;

b_p – half distance, in m, between the considered primary supporting member and the adjacent one;

l – span, in m, of primary supporting members.

7.13.6 The net thickness t , in mm, of the hatch cover top plating shall be not less than

$$t = F_p 15,8s \sqrt{\frac{p}{0,95\sigma_F}} \quad (7.13.6)$$

where: F_p – factor equal to:

1,9 – if ratio $\sigma/\sigma_a \geq 0,8$;

1,5 – in other cases;

s – stiffener spacing, in m;

p – pressure, in kPa, according to 7.13.3;

σ – according to 7.13.8;

σ_a – according to 7.13.4,

and not less than 1 % of the stiffener spacing or 6 mm, whichever is greater.

7.13.7 The required minimum section modulus Z , in cm^3 , of secondary stiffeners of the hatch cover top plates, based on stiffener net member thickness, are given by

$$Z = \frac{l^2 sp}{12\sigma_a} 10^3 \quad (7.13.7)$$

where: l – secondary stiffener span, in m, to be taken as the spacing of primary supporting members or the distance between a primary supporting member and the edge support, as applicable.

When brackets are fitted at both ends of all secondary stiffener spans, the secondary stiffener span may be reduced by an amount equal to 2/3 of the minimum brackets arm length, but not greater than 10 % of the gross span, for each bracket

s – secondary stiffener spacing, in m;

p – pressure, in kPa, according to 7.13.3;

σ_a – according to 7.13.4.

The net section modulus of the secondary stiffeners shall be determined based on an attached plate width assumed equal to the stiffener spacing.

7.13.8 The section modulus value and web thickness of primary supporting members, based on member net thickness, shall be such that the normal stress σ in both flanges and the shear stress τ in the web do not exceed the permissible values σ_a i τ_a , respectively, defined according to 7.13.4.

The width of the primary supporting members flange shall be not less than 40 % of their depth for laterally unsupported spans greater than 3,0 m.

Tripping brackets attached to the flange may be considered as a lateral support for primary supporting members.

The flange outstand shall not exceed 15 times the flange thickness.

7.13.9 The compressive stress s in the hatch cover plate panels, induced by the bending of primary supporting members parallel to the direction of secondary stiffeners, shall not exceed 0,8 times the critical buckling stress σ_{C1} , to be evaluated as follows:

$$\sigma_{C1} = \sigma_{E1}, \text{ when } \sigma_{E1} \leq \frac{\sigma_F}{2}; \text{ or}$$

$$\sigma_{C1} = \sigma_F \left[1 - \frac{\sigma_F}{4\sigma_{E1}} \right] \quad \text{when } \sigma_{E1} > \frac{\sigma_F}{2}, \quad (7.13.9-1)$$

where: σ_F - minimum upper yield stress of the material, in N/mm²;

$$\sigma_{E1} = 3,6E \left(\frac{t}{1000s} \right)^2;$$

where: E – modulus of elasticity, in N/mm² to be assumed $2,06 \cdot 10^5$ N/mm² for steel.

t - net thickness of plate panel, in mm;

s - spacing of secondary stiffeners, in m.

The mean compressive stress σ in each of the hatch cover plate panels, induced by the bending of primary supporting members perpendicular to the direction of secondary stiffeners, shall not exceed 0,8 times the critical buckling stress σ_{C2} , to be evaluated as follows:

$$\sigma_{C2} = \sigma_{E2}, \text{ when } \sigma_{E2} \leq \frac{\sigma_F}{2}, \text{ or}$$

$$\sigma_{C2} = \sigma_F \left[1 - \frac{\sigma_F}{4\sigma_{E2}} \right], \quad \text{when } \sigma_{E2} > \frac{\sigma_F}{2}, \quad (7.13.9-2)$$

where: σ_F - minimum upper yield stress of the material, in N/mm²;

$$\sigma_{E2} = 0,9mE \left(\frac{t}{1000s_s} \right)^2;$$

$$\text{де: } m = c \left[1 + \left(\frac{s_s}{l_s} \right)^2 \right]^2 \frac{2,1}{\psi + 1,1};$$

E – modulus of elasticity, in N/mm²;

t – net thickness of plate panel, in mm;

s_s – length of the shorter side of the plate panel, in m;

l_s – length of the longer side of the plate panel, in m;

ψ - ratio between the smallest and largest compressive stress;

c - коефіцієнт, що дорівнює:

1,3 when plating is stiffened by primary supporting members;

1,21 when plating is stiffened by secondary stiffeners of angle or T-type;

1,1 when plating is stiffened by secondary stiffeners of bulb type;

1,05 when plating is stiffened by flat bar.

7.13.10 The compressive stress in the top flange of secondary stiffeners, induced by the bending of primary supporting members parallel to the direction of secondary stiffeners, shall not exceed 0,8 times the critical buckling stress σ_{CS} , to be evaluated as follows:

$$\sigma_{CS} = \sigma_{ES}, \text{ when } \sigma_{ES} \leq \frac{\sigma_F}{2}, \text{ or}$$

$$\sigma_{CS} = \sigma_F \left[1 - \frac{\sigma_F}{4\sigma_{ES}} \right], \text{ when } \sigma_{ES} > \frac{\sigma_F}{2} \quad (7.13.10)$$

where: σ_F - minimum upper yield stress of the material, in N/mm²;

σ_{ES} - ideal elastic buckling stress, in N/mm², of the secondary stiffener to be assumed as the minimum between σ_{E3} and σ_{E4} ;

$$\sigma_{ES} = \frac{EI_a}{Al^2} 10^{-3};$$

E - modulus of elasticity, in N/mm²;

I_a - moment of inertia, in cm⁴, of the secondary stiffener, including an effective flange equal to the spacing of secondary stiffeners;

A - cross-sectional area, in cm², of the secondary stiffener, including an effective flange equal to the spacing of secondary stiffeners;

l - span, in m, of the secondary stiffener;

$$\sigma_{E4} = \frac{\pi^2 EI_w}{10^4 I_p l^2} \left(m^2 + \frac{K}{m^2} \right) + 0,385 E \frac{I_t}{I_p},$$

where:

$$K = \frac{Cl^4}{\pi^4 EI_w} \cdot 10^6;$$

m - number of half waves, given by the following table 7.13.10;

Table 7.13.10

$0 < K \leq 4$	$4 < K \leq 36$	$36 < K \leq 144$	$(m-1)^2 m^2 < K \leq m^2(m+1)^2$
$m = 1$	$m = 2$	$m = 3$	m , being determined according to K value

l_w - sectional moment of inertia, in cm⁶, of the secondary stiffener about its connection with the plating;

$$l_w = \frac{h_w^3 t_w^3}{36} 10^{-6} \text{ - for flat bar secondary stiffeners;}$$

$$l_w = \frac{f_t b_f^3 h_w^3}{36} 10^{-6} \text{ - for T-section secondary stiffeners;}$$

$$I_w = \frac{b_f^3 h_w^2}{12(b_f + h_w)^2} [t_f(b_f^2 + 2b_f h_w + 4h_w^2) + 3t_w b_f h_w] 10^{-6} \text{ - for angles and bulb secondary stiffener;}$$

I_p - polar moment of inertia, in cm⁴, of the secondary stiffener about its connection with the plating;

$$I_p = \frac{h_w^3 t_w}{3} 10^{-4} \text{ - for flat bar secondary stiffeners;}$$

$$I_p = \left(\frac{h_w^3 t_w}{3} + h_w^2 b_f t_f \right) 10^{-4} \text{ - for flanged secondary stiffeners;}$$

I_t - moment of inertia, in cm^4 , of the secondary stiffener without an effective flange;

$$I_t = \frac{h_w t_w^3}{3} 10^{-4} \text{ - for flat bar secondary stiffeners;}$$

$$I_t = \frac{1}{3} [h_w t_w^3 + b_f t_f^3 (1 - 0,63 \frac{t_f}{b_f})] 10^{-4} \text{ - for flanged secondary stiffeners;}$$

where: h_w, t_w - height and net thickness, in mm, of the secondary stiffener, respectively;

b_f, t_f - width and net thickness, in mm, of the secondary stiffener bottom flange, respectively;

s - spacing of secondary stiffeners, in m;

$$C = \left[\frac{k_p E t_p^3}{3s \left(1 + \frac{1,33 k_p h_w t_p^3}{1000 s t_w^3} \right)} \right] 10^{-3} ;$$

where: $k_p = 1 - \eta_p$, but not less than 0. For flanged secondary stiffeners, k_p need not be taken less than 0,1;

$$\eta_p = \frac{\sigma}{\sigma_{E1}} ;$$

for σ - refer to 7.13.8;

for σ_{E1} - refer to 7.13.9;

t_p - net thickness, in mm, of the hatch cover plate panel.

For flat bar secondary stiffeners and buckling stiffeners, the ratio h/t_w shall not be greater than $15k^{0,5}$,

where: h, t_w - height and net thickness of the stiffener, respectively;

$$k = 235 / \sigma_F ;$$

σ_F - minimum upper yield stress of the material, in N/mm^2 ;

7.13.11 The shear stress τ in the hatch cover primary supporting members web panels shall not exceed 0,8 times the critical buckling stress τ_c , to be determined as follows:

$$\tau_2 = \tau_2 \text{ when } \tau_E \leq \frac{\tau_F}{2} , \text{ or}$$

$$\tau_2 = \tau \left[1 - \frac{\tau_F}{4\tau_E} \right] , \text{ when } \tau_E > \frac{\tau_F}{2}$$

where: σ_F - minimum upper yield stress of the material, in N/mm^2 ;

$$\tau_F = \sigma_F / \sqrt{3};$$

$$\tau_E = 0,9 k_t E \left(\frac{t_{np,n}}{1000d} \right)^2 ;$$

where: E - modulus of elasticity, in N/mm^2 to be assumed $2,06 \cdot 10^5 \text{ N/mm}^2$ for steel.

$t_{np,n}$ - net thickness, in mm, of primary supporting member;

$$k_t = 5,35 + 4,0 / (a/d)^2 ;$$

a – greater dimension, in m, of web panel of primary supporting member;
 d – smaller dimension, in m, of web panel of primary supporting member.

For primary supporting members perpendicular to the direction of secondary stiffeners or for hatch covers built without secondary stiffeners, a presumed square panel of dimension d determination of the stress τ_c . In such a case, the average shear stress τ_c between the values calculated at the ends of this panel shall be considered.

7.13.12 The vertical deflection of primary supporting members shall be not more than $0,0056l$, where l is the greatest span of primary supporting members.

7.13.13 The free sectional area A , in cm^2 , of the securing device shall not be less than determined by the formula

$$A = 1,4a/f, \quad (7.13.13-1)$$

where: a – distance between securing devices, in m, which in any case shall not be adopted less than 2 m;

f – factor determined by the formula

$$f = (R_{eH} / 235)^e; \quad (7.13.13-2)$$

where: R_{eH} – the upper yield strength of the securing device material, in MPa, and shall not be adopted greater than 0,7 of the tensile strength of the material;

e – index equal to:

0,75 for $R_{eH} > 235$ MPa;

1,00 for $R_{eH} \leq 235$ MPa.

For hatch covers and hatch cover sections having an area in excess of 5 m^2 , the active diameter of bars and bolts of the securing devices shall not be less than 19 mm.

7.13.14 Where the packing gasket is compressed to the maximum depth possible and its pressure exceeds 5000 N/m, the area of securing devices as determined in accordance with **7.13.13**, shall be increased in a relevant proportion.

7.13.15 The stiffness of the cover corners shall be sufficient to maintain an adequate pressure of the packing gasket between the securing devices. The cross-sectional inertia moment of the corner members of the covers I , in cm^4 , shall be not less than that determined by the formula

$$I = 6pa^4 \cdot 10^{-3}, \quad (7.13.15)$$

where: p – pressure of the packing gasket when compressed to the maximum depth possible for the accepted design, in N/m, but not less than 5000 N/m;

a – distance between securing devices, in m.

7.13.16 Where hydraulic securing devices are applied, the securing devices shall be mechanically lockable in closed position in the event of loss of the hydraulic fluid.

7.13.17 Hatch covers shall be fitted with stoppers designed for longitudinal and transverse design loads of 175 kPa.

Where the design and arrangement of the forecabin on a ship do not meet the requirements in **3.3.5.4.1**, Part II "Hull", the stoppers of the foremost hatch cover (hatch No. 1) shall be designed for a longitudinal load of 230 kPa acting on the forward end of the No. 1 hatch cover.

7.13.18 The stresses in stoppers and their adjacent structures shall not exceed the permissible values equal to $0,8\sigma_F$, where σ_F is minimum upper yield stress of the material.

7.13.19 For the plating and stiffeners of all type hatch covers, excepting the double skin, the corrosion addition shall be assumed equal to 2 mm.

For double skin hatch covers, the corrosion addition shall be 2 mm for the top and bottom plating and 1,5 mm for the internal structures.

7.13.20 In bulk carriers of 150 m in length and upwards, carrying solid bulk cargoes having a density of 1000 kg/m^3 and above, contracted for construction before 1 April 2006, the protection of the structure of cargo

holds from grab wire damage during loading and unloading operations shall be achieved by structural design features:

wire rope grooving in way of cargo holds openings shall be prevented by fitting suitable protection such as half-round bar on the hatch side girders (i.e. upper portion of top side tank plates)/hatch end beams in cargo hold or upper portion of hatch coamings.

Such ships shall have the distinguishing mark GRAB(X) in the class notation (refer to **2.2.37.1**, Part I "Classification").

7.14 ACCESS TO SPACES IN THE CARGO AREA OF OIL TANKERS AND BULK CARRIERS

7.14.1 The requirements of **7.14** apply to oil tankers of 500 gross tonnage and above and to bulk carriers of 20 000 gross tonnage and above.

7.14.2 Means of access and passages on ships referred to in **7.14.1** shall comply with the requirements of IMO resolutions IMO MSC.133(76), MSC.158(78) taking into account MSC.1/Circ.1464/Rev.1, as well as IACS UI SC191 (Rev.8 Apr 2019) and in accordance with II-1/3-6 SOLAS-74 «Access to spaces in the cargo area of oil tankers and bulk carriers», the safety access requirements for which are set out in Annex 2 to this part of the Rules the safety access requirements for which are set out in Annex 2 to this part of the Rules.

Note. Unified requirements IACS (UR), unified interpretations IACS (UI), IACS Recommendations are published on the IACS website.

7.15 ADDITIONAL REQUIREMENTS FOR OPENINGS AND THEIR CLOSING APPLIANCES IN RO-RO SHIPS

7.15.1 Where vehicle ramps are installed to give access to spaces below the bulkhead deck, their openings shall be able to be closed weathertight to prevent ingress of water below, alarmed and indicated to the navigation bridge.

7.15.2 The Register may permit the fitting of particular accesses to spaces below the bulkhead deck provided they are necessary for the essential working of the ship, e.g. the movement of machinery and stores, subject to such accesses being made watertight, alarmed and indicated to the navigation bridge.

7.15.3 Subject to provisions of **7.15.1** and **7.15.2** all accesses that lead to spaces below the bulkhead deck shall have a lowest point which is not less than 2,5 m above the bulkhead deck.

7.15.4 Indicators shall be provided on the navigating bridge for all shell doors, loading doors and other closing appliances which, if left open or not properly secured, could lead to flooding of a special category space or ro-ro cargo space.

The indicator system shall be designed on the fail safe principle and shall show by light alarms if the door is not fully closed or if any of the securing arrangements is not in place and fully locked, and by audible alarms if such door or closing appliances become open or the securing arrangements become unsecured.

The indicator panel on the navigation bridge shall be equipped with a mode selection function "harbour/sea voyage" so arranged that an audible alarm is given on the navigation bridge if the ship leaves harbour with the bow doors, inner doors, stern ramp or any other side shell doors not closed or any closing device not in the correct position.

The power supply for the indicator system shall be independent of the power supply for operating and securing the doors.

7.15.5 Television surveillance and a water leakage system shall be arranged to provide an indication to the navigation bridge and to the engine control station of any leakage through inner and outer bow doors, stern doors or any other shell doors which could lead to flooding of special category spaces or ro-ro cargo spaces.

7.15.6 Special category spaces and ro-ro cargo spaces shall be continuously patrolled or monitored by effective means, such as television surveillance, so that any movement of vehicles in adverse weather conditions and unauthorized access of passengers thereto can be detected whilst the ship is underway.

7.15.7 Documented operating procedures for closing and securing all shell doors, loading doors and other closing appliances which, if left open or not properly secured could lead to flooding of special category space or ro-ro cargo space, shall be kept on board and posted at an appropriate place.

7.15.8 Besides specified in **7.15.7** the Manual on operation and repair of doors in shell plating shall be kept onboard containing the following information:

main particulars and structural drawings of doors;
door operation safety precautions;
ship characteristics;
door design loads;
manufacturer's recommendations for equipment testing;
description of equipment of bow, side and stern doors, internal bow doors, central power station, indication panel on navigation bridge, control panel in engine room;
operating characteristics:
permissible angles of heel/trim with/without cargo as well as permissible angles of heel/trim during use of doors;
door operating instruction;
door operating instruction in case of emergency;
operation and repair of doors:
description and deadlines of current repair, occurring failures and their acceptable elimination, manufacturer's instructions for operation and repair of doors;
record book of examinations including survey of securing, locking and supporting devices, repair and replacement.

The above manual on operation and repair of doors in shell plating shall be submitted for the Register approval.

8. ARRANGEMENT AND EQUIPMENT OF SHIP'S SPACES, VARIOUS EQUIPMENT, ARRANGEMENTS AND OUTFIT

8.1 GENERAL

8.1.1 The requirements for the arrangement and equipment of machinery spaces are specified in Part VII "Machinery Installations" and those relating to refrigerating machinery spaces, refrigerant storerooms, as well as refrigerated cargo spaces are set forth in Part XII "Refrigerating Plants".

8.1.2 In berth-connected ships, the arrangement and equipment of spaces, various devices and equipment shall comply with the relevant requirements of **8.5** and **8.6**.

Furthermore, berth-connected ships which are used as hotels or hostels shall comply with the requirements set out in **8.5** as in the case of passenger ships.

Besides, a berth-connected ship shall have at least two companion ladders fitted as far away from each other as possible.

The companion ladders shall be not less than 0,2 m wide where the total of passengers and crew on board does not exceed 50.

For each 10 persons above 50, the companion ladder breadth shall be increased by 5 cm.

8.2 LOCATION OF SPACES

8.2.1 The chart room shall be located in a space adjacent to the wheelhouse. The chart room and the wheelhouse may be situated in a common space.

8.2.2 No accommodation spaces shall be arranged forward of the collision bulkhead and abaft of the afterpeak bulkhead below the bulkhead deck.

8.3 NAVIGATION BRIDGE

8.3.1 General

8.3.1.1 The ship's control station shall be located in an enclosed space of the wheelhouse on the navigation bridge.

The navigation bridge shall be located so as to ensure:

proper visual control of the ship's running; good visibility with maximum view of water surface;

good audibility of sound signals of the approaching ships;

for tugs, possibility of visual control of tow line during towing operations.

It is recommended to arrange the steering control station at the ship's centreline.

8.3.1.2 Visibility from the navigation bridge shall comply with requirements of Chapter V of International Convention for the Safety of Life at Sea, 1974 (SOLAS 74), as amended by 1978 Protocol, 1988 Protocol relating there to with further amendments (SOLAS 74/78/88)

8.4 EQUIPMENT OF DRY CARGO HOLDS

8.4.1 When in ships not having double bottom wooden ceiling is placed on top of the floors, it shall be solid and shall extend up to the bilge. The ceiling is recommended to be made of portable sections of such dimensions and so constructed as to allow of their ready removal at any place.

The thickness of a ceiling shall be:

at least 40 mm for ships of 30 m in length and less;

at least 60 mm for ships over 30 m in length;

at least 70 mm under cargo hatchways.

8.4.2 When in ships having double bottom wooden ceiling is fitted, it shall have a thickness as follows:

at least 50 mm for ships of 60 m in length and less;

at least 65 mm for ships over 60 m in length.

8.4.3 Where cargo is discharged by grabs or other mechanisms, the thickness of the wooden ceiling fitted under cargo hatchways shall be doubled.

8.4.4 In holds intended for carriage of grain and other bulk cargoes the wooden ceiling on the inner bottom or, in case the latter is omitted, on the top of floors, shall be fitted so as to prevent wells, bilges and suction pipes of the bilge system from clogging.

8.4.5 The wooden ceiling shall not be laid directly on the inner bottom metal plating, but shall be embedded in a bituminous or epoxy composition approved by the Register, or placed on battens of 25 ÷ 30 mm, mm in thickness along the floors.

The wooden ceiling over the bilges shall be placed so as to be readily removable (refer also to **7.6.9**, Part VIII "Systems and Piping").

8.4.6 It is recommended that the cargo battens made of wood or metal shall be fitted on sides in holds and spaces intended for carriage of general cargoes.

The thickness of wooden battens shall be as follows:

at least 40 mm for ships of 70 m in length and less;

at least 50 mm for ships of length exceeding 70 m.

The distance between adjacent battens shall not exceed 305 mm.

The battens shall be attached to side framing so as to be readily removable and replaceable.

8.4.7 All projecting parts of various equipment in the holds (manholes, air pipes, sounding pipes, etc.) shall be protected with wooden screens, grids, chutes, etc. in places subject to impacts of cargoes, grabs or other hoisting devices.

Requirements for laying pipe lines in cargo holds are given in **5.3**, Part VIII "Systems and Piping".

8.4.8 Cellular guide members for the carriage of containers in holds.

8.4.8.1 The requirements of **8.4.8** apply to the cellular guide members used for the carriage of containers, manufactured in accordance with the Rules for the Construction of Containers, in the holds of cargo ships.

8.4.8.2 Cellular guide members comprise uprights and horizontal shores arranged breadthwise and lengthwise. In the holds, the cellular guide members may be removable or permanent.

8.4.8.3 Cellular guide members shall not be integrated in the hull structure. They shall be so designed that no stresses are exerted on them when the hull comes under bending or torsion.

8.4.8.4 Cellular guide members shall be designed to withstand stresses due to the forces F_x and F_y affecting the gravity centre of each container, which shall be determined by the formulae:

lengthwise

$$F_x = mga_x; \quad (8.4.8.4-1)$$

breadthwise

$$F_y = mga_y, \quad (8.4.8.4-2)$$

where: m – maximum gross mass of container, in kg;

g – gravity acceleration, $g=9,81 \text{ m/s}^2$;

a_x , a_y – dimensionless accelerations to be determined in accordance with 1.7, the coordinates of x and z being determined up to the gravity centre of each container volume.

The forces F_x and F_y shall be determined for each container, and through the four relevant corner fittings of the end or side wall they are uniformly distributed among the uprights. By way of simplification, maximum F_x and F_y values may be adopted for each container. Where a number of adjoining containers are supported by a pair of uprights, the F_x and F_y values for the particular container tier shall be summed up and distributed among the respective uprights.

Friction forces arising where the corner fittings of containers touch each other or the inner bottom shall be ignored.

8.4.8.5 The forces resultant from loads to be determined in accordance with 8.4.8.4, where the container corner fittings rest upon the uprights, shall not exceed 150 kN per fitting breadthwise or 75 kN per fitting lengthwise.

8.4.8.6 Where the attachment of uprights to the hull structures is not considered as firm fixing (free resting, flexible fixing, etc.), the cellular guide members shall be calculated as three-dimensional frames.

Where the attachment of uprights to the hull structures can be considered as firm fixing, particular vertical surfaces of cellular guide members may be calculated as plane frames.

The stresses in the cellular guide member components shall not exceed 0,8 times the upper yield stress of their material.

The terms of calculating the stability of cellular guide member components shall be found under **8.4.8.14**.

8.4.8.7 In view of the requirements under **8.4.8.6**, the displacement of the resting points of corner fittings upon the uprights shall not exceed 25 mm breadthwise or 40 mm lengthwise.

8.4.8.8 When determining the thickness of the uprights components, the thickness of those especially subject to wear shall be increased by 5 mm and equal to at least 12 mm.

8.4.8.9 Where the uprights comprise separate angular sections, they shall be firmly secured to each other with horizontal plates at the resting points of container corner fittings and at least halfway between those points.

8.4.8.10 At the upper ends of the uprights, devices shall be fitted to facilitate the insertion of containers into the stowage frames. **8.4.8.11** Uprights shall, so far as possible without notches, be attached to transverse and longitudinal bulkheads by means of shear- and bend-stiff members.

8.4.8.12 The total margin between the external scantlings of containers and the internal uprights surfaces shall not exceed 25 mm breadthwise or 40 mm lengthwise.

When fitting the uprights, the deviation from the straight line shall not exceed 5 mm.

8.4.8.13 Transverse horizontal and longitudinal horizontal shores serve to connect the stand-alone uprights to each other and to secure them to vertical hull structures. The horizontal shores shall, as far as possible, be fitted on the level of the corner fitting rest points and be torsion- and bend-stiff connected to the uprights.

8.4.8.14 The stability of transverse horizontal and longitudinal horizontal shores and, where necessary, that of uprights shall be checked by a procedure approved by the Register.

When determining the permissible buckling stresses, the relevant safety factor may be adopted equal to 2,0.

The free length of buckling shall be adopted span-equal in the case of a bolted joint or 0,7 times the shore or uprights span in the case of a welded joint. The flexibility shall not exceed 250.

For other types of bar-end fixing, the free length shall be established according to the procedure approved by the Register.

8.4.8.15 The container rest points on the inner bottom and areas containing the connections and attachments of container stowage frames in way of hull structures shall be strengthened in conformity with the requirements of Part II "Hull".

8.4.9 Movable decks, platforms, ramps and other similar structures.

8.4.9.1 The requirements of **8.4.9** apply to the movable decks, platforms, ramps and other similar structures designed to be installed in two positions:

in working position when they are used for carriage, loading or unloading of vehicles or other cargoes;

in non-working position when they are not used for carriage, loading or unloading of vehicles or other cargoes.

8.4.9.2 The movable decks, platforms, ramps and other similar structures and also their supporting elements at ship's sides, decks and bulkheads. the pillars or suspensions for decks and platforms ensuring their proper installation in the working position shall be designed in accordance with the requirements of Part II

"Hull".

8.4.9.3 Arrangements shall be provided for reliable securing of the movable decks, platforms ramps and other similar structures in the non-working position.

8.4.9.4 When the movable decks, platforms, ramps and other similar structures are secured in the nonworking position, the hoisting gear and elements thereof shall not generally be kept under the load.

It is not permitted to secure the movable decks, platforms, ramps and other similar structures by suspending them on ropes.

8.4.9.5 The structural elements of the arrangements mentioned in **8.4.9.3** and also the associated supporting structures shall be designed to withstand the forces resulting from the application of the load P_x , P_y and P_z , as determined by the formulae given below, to the centres of gravity of the considered section of the deck, platform, ramp or other similar structures:

$$P_x = mga_x, \quad (8.4.9.5-1)$$

$$P_y = mga_y, \quad (8.4.9.5-2)$$

$$P_z = mg(1 + a_z), \quad (8.4.9.5-3)$$

where: P_x – horizontal load parallel to the centreline of the ship, in N. Consideration shall be given to the cases when the load P_x is directed both forward and aft;

P_y – horizontal load parallel to the midstation plane, in N. Consideration shall be given to the cases when the load P_y is directed both to the nearest ship's side and to the opposite side;

P_z – vertical load directed downward, in N;

m – mass of the considered section of the deck, platform, ramp or other similar structure, in kg;

g – acceleration due to gravity equal to 9,81 m/s²;

a_x , a_y , a_z – dimensionless accelerations to be determined in accordance with **1.7**.

8.4.9.6 When determining the forces affecting the structural elements of the arrangements specified in **8.4.9.3** and the associated supporting structures with regard to the provisions of **8.4.9.5**, the loads P_x , P_y and P_z are regarded as separately applied, i.e. no account is taken of their combined action and of the frictional forces originating on the surfaces of the considered sections of decks, platforms, ramps or other similar structures which are in contact with the associated supporting structures.

8.4.9.7 When the structural elements of the arrangements specified in **8.4.9.3** and the associated supporting structures are under the effect of the loads determined according to the provisions of **8.4.9.5** and **8.4.9.6**, the stresses in their parts shall not exceed 0,8 times the upper yield stress of material.

Under the effect of these loads the safety factor of the wire ropes in relation to their breaking strength shall be not less than 4;

the safety factor of the chain cables in relation to the proof load of the chain shall be not less than 2;

the margin of safety against buckling of the elements subjected to the compression stress shall be not less than 2.

8.4.9.8 Wire ropes used in the arrangements specified in **8.4.9.3** shall satisfy the requirements of **3.15** and chain cables, those of **7.1**, Part XIII "Materials".

8.5 EXITS, DOORS, CORRIDORS, STAIRWAYS AND VERTICAL LADDERS

8.5.1 General.

8.5.1.1 Location and arrangement of exits, doors, corridors, stairways and vertical ladders shall ensure the possibility of quick, safe and free access from spaces to the embarkation stations of lifeboats and liferafts.

Additional means for outdoor escape shall be clearly marked, where necessary, to ensure accessibility, and be provided with a proper design to be used in emergency.

8.5.1.2 In passenger ships, access protection of the stairway enclosures to lifeboats and liferafts embarkation areas shall be provided both directly and through protected internal evacuation routes, which stairway enclosures shall be fire resistant and insulated, as appropriate, as shown in Tables 2.2. 1.3- 1, 2.2.1.3-2, 2.2.1.5-1, 2.2.1.5-2 of Part VI "Fire Protection".

8.5.2 Exits and doors.

8.5.2.1 In passenger ships and in special purpose ships each watertight compartment or similarly restricted space or group of spaces situated below the bulkhead deck shall have at least two means of escape, in any case one of which shall be independent of the door in the subdivision bulkhead.

At least one of the evacuation routes shall comply with the requirements of **2.2.2.4.5**, Part VI "Fire Protection" to the appropriate lifeboats or life rafts embarkation decks or to the upper deck if the life-saving appliances embarkation deck does not extend to the main vertical fire zone.

In the latter case, direct access to the life-saving appliances embarkation deck shall be provided by means of external open ladders and passages, which shall be provided with lighting in accordance with **8.5.5**, and also nonsliding surface. Limiting structures facing open ladders and passages that are part of the evacuation route and limiting structures located in a place where their damage by fire may obstruct the passage to the embarkation deck shall be fire-resistant and have an insulation value, as appropriate, according to Tables 2.2.1.3-1, 2.2.1.3-2, 2.2.1.5-1, 2.2.1.5-2, Part VI "Fire Protection".

In passenger ships of restricted areas of navigation **B-R3-RS**, **B-R3-RS**, **C-R3-S**, **C-R3-RS** та **D-R3-S**, **D-R3-RS**, in exceptional cases, taking into account the purpose of the room and the number of persons usually accommodated in them, only one exit, which shall ensure safe evacuation, may be provided.

Two ways of evacuation from the main machinery control room located in the engine room shall be provided; at least one of them shall provide continuous protection from fire to a safe place outside the engine room (refer to **2.1.4.5**, Part VI "Fire Protection").

8.5.2.2 In passenger ships and in special purpose ships above the bulkhead deck each main vertical fire zone (refer to **2.2.1.2**, Part VI "Fire Protection") or similarly restricted space or group of spaces shall have at least two means of escape one of which shall give access to a stairway forming a vertical means of escape to the places of embarkation into lifeboats and liferafts.

8.5.2.3 In passenger ships the number and location of means of escape from special category spaces (refer to **1.5.9**, Part VI "Fire Protection") depend on the degree of safety; the degree of safety for escape from these spaces to the embarkation stations of lifeboats and liferafts shall at least correspond to that specified in **8.5.2.1** and **8.5.2.2**.

For cargo ships in all ro-ro cargo spaces where the crew is normally employed, at least two widely separated escape routes shall be provided.

8.5.2.4 In cargo ships of 500 gross tonnage and upwards at each level of accommodation spaces there shall be at least two means of escape, as widely separated as possible, from each restricted space or group of spaces; from the spaces situated below the open deck the main means of escape shall be formed by a stairway, the other means of escape may be formed by a casing with a vertical ladder or by a stairway; from spaces above the open deck the means of escape shall be stairways or doors to an open deck or a combination thereof.

The open deck stated above shall be a category (10) (in accordance with **2.2.1.5**, Part VI "Fire Protection").

8.5.2.5 Spaces may be dispensed with one of the means of escape required under **8.5.2.1** or **8.5.2.4**, due regard being paid to the nature and location of the spaces and to the number of persons normally employed therein.

8.5.2.6 Stairways serving only a space and a balcony in that space, as well as lifts shall not be considered as means of escape specified in **8.5.2.1** ÷ **8.5.2.4**.

8.5.2.7 Each cinema hall shall be provided with at least two means of escape. Both exits shall be spaced from each other as wide as practicable. A readily seen inscription "Exit" or "Emergency exit" shall be provided above every such exit.

8.5.2.8 In case of open bridge wings, the wheelhouse shall have two exits, one to each side of the navigation bridge, with a passageway through the house from side to side.

8.5.2.9 The total width of exits from cinema halls shall be determined on the basis of 0,8 m per 50 persons, however, the width of each exit shall be not less than 1,1 m, when the number of seats is more than 50, and not less than 0,8 m when the number of seats is not more than 50. The width of each exit from accommodation and service spaces shall be not less than 0,6 m.

The sizes of the ladderways from cargo holds shall be not less than 0,6x0,6 m.

8.5.2.10 The exit doors and ladderway covers shall be so arranged that they can be operated from both sides. Doors shall open as follows:

.1 doors of accommodation, excluding public, and service spaces giving access to a corridor inside the spaces;

.2 doors of public rooms, outwards or each side;

.3 doors in the end bulkheads of superstructures and in external transverse bulkheads of deckhouses, outwards in the direction of the nearest side;

.4 doors in the external longitudinal bulkheads of deckhouses, outwards in the forward direction.

In cargo ships the inner doors duplicating the doors specified in **8.5.2.10.3** and **8.5.2.10.4** may open inside the space.

In ships of 31 m in length and less the doors indicated in **8.5.2.10.1** may open outwards (to the corridor) if they are situated at the end of blind corridors and do not hinder the exits from other spaces.

No sliding doors shall be fitted at exits and means of escape, except for doors of the wheelhouse.

The doors referred to in **8.5.2.10.1** shall not be provided with hooks for holding the door open. It is permitted that such doors be fitted with buffers and spring catchers to fix the door in the open position and to allow for its closure without entering the space.

The doors specified in **8.5.2.10.3** and **8.5.2.10.4** may open in a different direction when security against the impact of the sea and safe passage are provided.

8.5.2.11 Doors of accommodation spaces specified in **1.5.2.1** and **1.5.2.2**, Part VI "Fire Protection" shall have in their lower portions detachable panels 0,4 x 0,5 m in size, these panels of the passenger cabin doors shall be provided with the following inscription: "Means of escape — knock out in case of emergency".

The detachable panels need not be fitted where the spaces are provided with opening type side scuttles of at least 400 mm in diameter of windows the smaller side of which being at least 400 mm and on condition that persons may get to the corridor or open deck through these side scuttles or windows.

The appropriate means shall be provided, if necessary, to facilitate exit through side scuttles or windows.

8.5.2.12 In arrangement and disposition of exits and doors in dangerous zones, spaces and areas of oil tankers and oil recovery ships, as well as of ships carrying dangerous goods requirements shall be considered with respect to the safe-type electrical equipment to be used in spaces adjacent to dangerous zones with the doors open into such spaces (refer to **19.2** and **19.11**, Part XI "Electrical Equipment").

8.5.2.13 The doors of evacuation routes from public premises, which usually stopped, shall be equipped with means for their quick release. Such means shall consist of a stopper device of the doors, which is combined with a device that quickly releases the stopper when applying force in the direction of movement to the outside.

Stopper quick release device:

.1 shall consist of a bolt or panel, the effective part of which is located at least half the width of the door plate, but not less than 760 mm, and not more than 1120 mm above the deck;

.2 shall release the door stopper when using force of not more than 67 N; and

.3 shall not be equipped with any locking device, locking screw or other device preventing the release of the stopper under the force that is applied to the door release device.

8.5.2.14 The aggregate width of exits from premises intended for use by people with reduced mobility shall not be less than 0.9 m. The aggregate width of exits commonly used for embarking and disembarking people with reduced mobility shall not be less than 1.5 m.

Minimum clearance of 0.6 m between the door end of the door frame and the side of the lock and the adjacent perpendicular wall shall be provided for doors intended for people with reduced mobility.

8.5.3 Corridors and passageways.

8.5.3.1 All corridors and passageways shall ensure free movement of persons along them. On passenger ships and special purpose ships carrying more than 60 persons, a lobby, corridor or part of a corridor shall have more than one means of escape.

Cargo ships and special purpose ships carrying not more than 60 persons shall have no dead-end corridors more than 7 m long.

By a dead-end corridor, a corridor or part of a corridor is meant which has only one means of escape.

Corridors used as means of escape on cargo ships shall be at least 700 mm wide and shall be fitted with a handrail on either side. Corridors with a width of 1800 mm and more shall be fitted with handrails on each side. Width of a corridor is determined as a distance between a handrail and opposite bulkhead or as a distance between handrails.

8.5.3.2 The width of main corridors in way of passengers' and crew's accommodation spaces shall not be less than 0,9 m, and that of side corridors shall be at least 0,8 m. Where the number of passengers and crew using the corridor surpasses 50 persons, the widths referred to above shall be increased by 0,1 m.

In ships (including the tugs) below 500 gross tonnage and in tugs of less than 370 kW the width of the main corridors and side corridors may be reduced down to 0,8 and 0,6 m, respectively.

8.5.3.3 The widths of passageways in the cinema hall and in the entrance hall shall not be less than 1,1 m and 1,4 m, respectively.

The width of the main passageways in the restaurant or dining room and also the messroom shall not be less than 0,9 m and that of the side passageways shall be at least 0,65 m.

In ships of less than 500 gross tonnage the width of main passageways in the messroom may be reduced down to 0,65 m.

8.5.3.4 The width of the main passageway in the seating passenger space shall be at least 1 m with number of passengers up to 50 and at least 1,1 m with number of passengers in excess of 50.

8.5.3.5 In passenger ships the main corridors adjacent to engine and boiler casings shall be at least 1,2 m in width, however, in ships of less than 500 gross tonnage this width may be reduced down to 0,9 m.

8.5.3.6 The width of passageway on the bridge shall not be less than 0,8 m in ships of 500 gross tonnage and over and at least 0,6 m in ships of less than 500 gross tonnage.

8.5.3.7 In passenger ships and special purpose ships the width of the deck passageways providing access to the lifeboat and liferaft embarkation deck shall not be less than:

0,9 m if the number of seats in lifeboats is not more than 50 on each side of ship;

1,0 m if the number of seats in lifeboats is 50 and over, but less than 100 on each side of ship;

1,2 m if the number of seats in lifeboats is 100 and over, but less than 200 on each side of ship.

If number of seats in lifeboats is 200 and over on each side, the width of the passageways shall be determined according to the procedure approved by the Register.

In other ships the width of the passageways referred to above shall not be less than 0,8 m.

8.5.3.8 The width of openings for embarkation and disembarkation of people with reduced mobility shall not be less than 1.5 m.

Overall width of areas intended for use by passengers with reduced mobility shall not be less than 1.3 m and shall be free of thresholds greater than 0.025 m high. Walls in passage areas intended for passengers with reduced mobility shall be equipped with handrails at a distance 0.9 m above the floor.

The width of connecting passages intended for people with reduced mobility shall be not less than 1.30 m. Connecting passages with width in excess of 1.5 m shall be provided with handrails on both sides.

Passages to such access routes shall be indicated on other access routes to the ship and in other appropriate places throughout the ship.

8.5.4 Stairways and vertical ladder.

8.5.4.1 All between deck stairways shall be of steel frame construction or of equivalent material on agreement with the Register (refer to **1.2**, Part VI "Fire Protection"). Special requirements for arrangement of stairway enclosures and protection of means of escape are specified in **2.1.4.3**, **2.1.4.5**, **2.2.2.4**, Part VI "Fire Protection".

The back side of the stairways in machinery space is to be provided with metal binder.

8.5.4.2 On passenger ships and special purpose ships carrying more than 60 persons, the following conditions shall be met:

.1 the width of stairways shall be not less than 900 mm, with handrails on each side. The minimum width of stairways shall be increased by 10 mm for every one person in excess of 90 persons. The maximum width between handrails where stairways are wider than 900 mm shall be 1800 mm. The total number of persons to be evacuated by such stairways shall be assumed to be two-thirds of the crew and the total number of passengers in the areas served by such stairways;

.2 all stairways sized for more than 90 persons shall be aligned fore and aft;

.3 the doorways, corridors and intermediate landings included in means of escape shall be sized in the same manner as stairways;

.4 stairways shall not exceed 3,5 m in vertical rise without the provision of a landing and shall not have an angle of inclination greater than 45°;

.5 with the exception of intermediate landings, the landings at each deck level shall not be less than 2 m² in area and shall increase by 1 m² for every 10 persons provided for in excess of 20 persons but need not exceed 16 m², except for those landings servicing public spaces having direct access onto the stairway enclosure;

.6 in any case, the stairway width shall be in accordance with the requirements of the Appendix 1 to this Part;

.7 Stairways intended for people with reduced mobility shall meet the following requirements: the angle of inclination shall not exceed 32°;

the width of stairways shall be not less than 0.9 m;

spiral staircases are not allowed; stairways shall not be located in the direction perpendicular to the ship's center line;

stairways handrails are to extend approximately 0,3 m beyond the limits of its upper and lower parts without any restriction of passage;

handrails, the front parts of at least the first and last steps, as well as the floor covering at the ends of the steps, shall be painted in bright colors;

elevators for people with reduced mobility and lifting equipment, such as escalators or lifting platforms, shall comply with standards approved by the Register.

8.5.4.3 Stairways used as means of escape on cargo ships shall be at least 700 mm wide and shall be fitted with a handrail on either side.

Stairways with a width of 1800 mm and more shall be fitted with handrails on each side. In cargo ships of less than 500 gross tonnage the width of stairways may be 600 mm.

Angle of slope of ladders shall be usually 45° but not greater than 50°, in the machinery and in small spaces - not greater than 60°.

In ships of less than 500 gross tonnage in case of insufficient space at egress from the stairway with angle of slope of ladders of 55° in accommodation and service spaces, with 60° - on decks.

The size of doors providing an access to any stairway shall be of the same size as the stairway.

8.5.4.4 Vertical ladders and ladder steps in cargo holds, tanks, etc. shall be at least 300 mm wide.

8.5.5 Low location lighting (LLL) on passenger ships carrying more than 36 passengers and special purpose ships carrying more than 240 persons.

8.5.5.1 In addition to the emergency lighting stipulated by **19.1.2**, Part XI "Electrical Equipment", the means of escape, including stairways and exits, of passenger ships carrying more than 36 passengers and special purpose ships carrying more than 240 persons shall be marked by LLL at all points of the escape route including angles and intersections.

8.5.5.2 Provision shall be made for the following LLL systems: .1 photoluminescent system which uses photoluminescent material containing a chemical (example: zinc sulfide) that has the quality of storing power when illuminated by visible light;

.2 electrically powered systems which use incandescent bulbs, light emitting diodes, electroluminescent strips or lamps, electrofluorescent lamps, etc. (refer also to **19.1.4**, Part XI "Electrical Equipment").

8.5.5.3 The LLL system shall function at all times for at least 1 h after its activation. All systems, including those automatically activated or continuously operating, shall be capable of being manually activated by a single action from the main control station.

8.5.5.4 In all passageways, the LLL shall be continuous except as interrupted by corridors and cabin doors in order to provide a visible delineation along the escape route. The LLL shall be installed at least on one side of the corridor, either on the bulkhead within 300 mm of the deck, or on the deck within 150 mm of the bulkhead. In corridors more than 2 m wide, LLL shall be installed on both sides. In dead-end corridors, LLL shall have arrows placed at intervals of no more than 1 m, or equivalent direction indicators, pointing away from the dead-end.

8.5.5.5 In all stairways, LLL shall be installed on at least one side at a height less than 300 mm above the steps. LLL shall be installed on both sides if the width of the stairway is two metres or more. The top and bottom of each set of stairs shall be identified to show that there are no further steps.

8.5.5.6 In all passenger cabins, a placard explaining the LLL system shall be installed on the inside of the cabin door. It shall also have a diagram showing the location of, and the way to, the two closest exits with respect to the cabin. Materials used in the manufacture of LLL products shall not contain radioactive or toxic materials.

8.5.5.7 LLL shall indicate the exit door handle; other doors shall not be indicated so.

Sliding, fire-proof and watertight doors shall be provided with LLL sign showing the way of the door opening.

LLL signs shall be also provided at all doors and means of escape. The signs shall be located at a height of 300 mm above the deck or the bottom of the door and be contrast in colour to the background on which they are marked.

All exit door and escape route signs shall be of photoluminescent materials or marked appropriately by lighting.

8.5.5.8 Photoluminescent (PL) material strips shall be not less than 75 mm wide. The strips having a width less than that stated herein shall be used only if their luminance is increased proportionally to compensate for their width. PL materials shall provide at least 15 mcd/m² measured 10 min after removal of all external illuminating sources. The system shall ensure luminance values greater than 2,0 mcd/m² for 1 h. Any PL system shall be provided with not less than the minimum level of ambient light necessary to charge the PL material to meet the above luminance requirements.

8.5.5.9 Electrically powered LLL system shall comply with the requirements of **2.2.8.6.6**, Part VI "Fire Protection".

For ships having length of 120 m or more or having three or more main vertical zones the electrically powered LLL system shall also comply with the requirements of **2.2.7.4.3**, Part VI "Fire Protection".

8.5.5.10 In passenger ships, the passenger and crew cabins shall be fitted with LLL.

8.5.6 Additional requirements for means of escape on ro-ro passenger ships.

8.5.6.1 Handrails or other handholds shall be provided in all corridors along entire escape route, so that a firm handhold is available every step of the way, where possible, to the assembly stations and embarkation stations. Such handrails shall be provided on both sides of longitudinal corridors more than 1,8 m in width and transverse corridors more than 1 m in width. Particular attention shall be paid to the need to be able to cross lobbies, atriums and other large open spaces along escape routes. Handrails and other handholds shall be of such strength as to withstand a distributed horizontal load of 750 N/m applied in the direction of the centre of the corridor or space, and a distributed vertical load of 750 N/m applied in downward direction. There is no need to apply the two loads simultaneously.

8.5.6.2 Means of escape shall not be obstructed by furniture and other obstructions, with the exception of tables and chairs which may be cleared away to provide open space. Cabinets and other heavy pieces of furniture in public spaces and along escape routes shall be secured in place to prevent shifting if the ship rolls or lists. Floor coverings shall also be secured in place. When the ship is underway, means of escape shall be kept clear of obstructions.

8.5.6.3 Means of escape shall be provided from every normally occupied space on the ship. These means of escape shall be arranged so as to provide the shortest route possible to the assembly stations and survival craft embarkation stations and shall be marked with appropriate symbols.

8.5.6.4 Where enclosed spaces adjoin an open deck, openings from the enclosed space to the open deck shall, where it is practicable, be capable of being used as an emergency exit.

8.5.6.5 Decks shall be sequentially numbered, starting with "1" at the tank top or the lowest deck. These numbers shall be prominently displayed at stair landings and lifts in the lobbies. Decks may also be named, but the deck number shall always be displayed along with the name.

8.5.6.6 Simple and clear plans showing the "you are here" position and means of escape marked by arrows shall be prominently displayed on the inside of each cabin door and in public spaces.

8.5.6.7 Cabin and stateroom doors shall not require keys to be unlocked from the inside. Neither shall there be any doors along any designed escape route which require keys to be unlocked.

8.5.6.8 The lowest 0,5 m of bulkheads along escape routes shall be able to sustain a load of 750 N/m to allow them to be used as walking surfaces with the ship at large angles of heel.

8.5.6.9 The escape routes from cabins to stairway enclosures shall be as direct as possible, with a minimum number of direction changes. It shall not be necessary to cross from one side of the ship to the other to reach means of escape. It shall not be necessary to climb more than two decks up or down to reach an assembly station or open deck from any passenger space.

8.5.6.10 External means of escape to the survival craft embarkation stations shall be provided from all open decks, referred to in **8.5.6.9**.

8.5.6.11 Lifting ramps for entering / leaving on decks, platforms, ramps, when they are in the lowered position, shall not block the evacuation routes.

8.5.6.12 On passenger roll-on roll-off ships (such as ro-ro), evacuation routes are to be assessed on the basis of evacuation analysis at the design stage. The analysis is to be used to identify and warn, as far as possible, places of congestion that may occur when the ship is abandoned due to the usual movement of passengers and crew along escape routes, including the possibility that the crew may need to move these routes in the direction, opposite to the movement of passengers. In addition, an analysis is to be used to demonstrate that the organization of evacuation routes is sufficiently flexible to ensure that certain evacuation routes, muster stations, embarkation stations, life-saving appliances themselves may not be accessible due to an emergency.

8.6 GUARD RAILS, BULWARK AND GANGWAYS

8.6.1 All exposed parts of the freeboard decks, superstructure decks and deckhouse tops shall be provided with efficient guard rails or bulwarks; in case of ships intended for carriage of timber deck cargo collapsible railing or storm rails shall be fitted on this cargo.

8.6.2 The height of the bulwark or guard rails above the deck shall not be less than 1 m. However, where this height would interfere with the normal operation of the ship, a lesser height may be approved provided the adequate protection of passengers and crew is ensured to the satisfaction of the Register.

8.6.3 The distance between the stanchions of the guard rails shall be not more than 1,5 m. At least every third stanchion shall be supported by a stay.

Removable and hinged stanchions shall be capable of being locked in the upright position. For deck plating exceeding 20 mm the support may be omitted.

In places of such stanchions weld to the deck, the deck shall be supported by a minimum 100x12 mm stiffener.

It is allowed to use flat steel stanchions with increased breadth at the stanchion weld to the deck.

Fig. 8.6.3 shows the installation diagram and the spacing between the stanchions depending on the breadth of the lower edge to be welded to the deck.

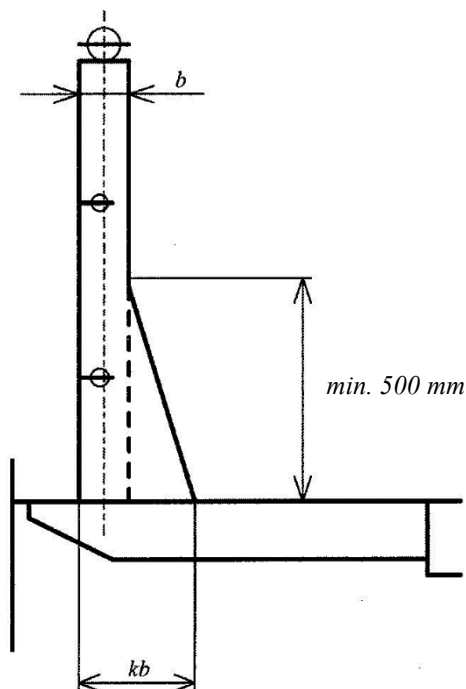

Fig.8.6.3

1. Where $kb \geq 2,9b$ - at least every third stanchion shall be of increased breadth.
 2. Where $2,4b \leq kb < 2,9b$ - at least every second stanchion shall be of increased breadth.
 3. Where $1,9b \leq kb < 2,4b$ - at least every stanchion shall be of increased breadth.
- The stanchion breadth b , shall be chosen according to the design standards.

8.6.4 The gunwale, hand rails and guard rails shall be generally of rigid construction; wire ropes may only be accepted in lieu of guard rails in special circumstances and then only in limited lengths; wire ropes shall be made taut by means of turn-buckles.

Lengths of chains may only be accepted in lieu of rigid guard rails if they are fitted between two fixed stanchions or between the fixed stanchion and bulwark.

8.6.5 The opening below the lowest course of the guard rails shall not exceed 230 mm. The other courses of rails shall not be more than 380 mm apart. An exception is made for the guard rails above the timber deck cargo where the height from the base to the lowest course and other course spacings shall not exceed 330 mm. In the case of ships with rounded gunwale, the guard rail supports shall be placed on the flat of the deck.

8.6.6 Type "A" ships with bulwarks as well as type "B" ships with a freeboard reduced to that required for type "A" ships shall have open rails fitted for at least half the length of the exposed parts of the weather deck, or other effective water freeing arrangements. The upper edge of the sheerstrake shall be kept as low as practicable.

Where superstructures are connected by trunks, open rails shall be fitted for the whole length of the exposed parts of the freeboard deck.

8.6.7 The bulwark, if arranged, shall comply with the requirements of 2.14, Part II "Hull".

8.6.8 Satisfactory means (in the form of life lines, gangways, underdeck passages, etc.) shall be provided for the protection of the crew in getting to and from their accommodation spaces, the machinery space and all other parts used in the necessary work of the ship.

8.6.9 A fore and aft permanent gangway shall be provided on type "A" ships at the level of the superstructure deck between the poop and the midship superstructure or deckhouse, where fitted, or equivalent means of access shall be provided to carry out the purpose of the gangway, such as underdeck passages. The

width of the passages shall be not less than 1 m. The gangways over the entire length of the plating on either side shall be fitted with longitudinal guarding bars. Reliable guard rails, the dimensions of which shall comply with the requirements of **8.6.2**, **8.6.3** and **8.6.5** of this Part, and **3.5.5.2**, Part II "Hull" shall be provided.

The gangways shall be constructed of a fire-resisting material, and the plating shall be made, in addition, of a non-slip material.

The plating may be manufactured of fibre reinforced plastic provided it complies with the requirements of 6.9, Part XIII "Materials".

In ships not having a midship superstructure arrangements to the satisfaction of the Register shall be made to safeguard the crew in reaching all parts of the ship while at sea.

8.6.10 Safe and convenient ladders from the level of the gangways to the deck shall be provided; they shall not be spaced more than 40 m apart.

Where the length of the deck is more than 70 m, special tripartite shelters (bow - sides) shall be provided along the gangways or other means of access for protection of the crew from bad weather. Such shelters shall be designed for at least one person and shall be spaced not more than 45 m apart. Pipes or other deck equipment shall not impede safe passage.

8.6.11 Requirements of Part VI «Fire Protection» and **8.6.1** ÷ **8.6.10** are not applied to the shipborne barges (lighters), barges and other non-self-propelled ships unmanned.

8.6.12 On ships open decks where access of passengers is allowed, bulwarks or guard rails shall be at least 1.1 m high above the deck and be fitted with a structure that prevents passengers from climbing over guard railing and accidental falling off the deck.

Stairways and ladders on such decks are to be equipped with a guard railing of a similar construction.

8.6.13 Deck bulwarks and railings intended for use by persons with reduced mobility shall not be less than 1.1 m high.

The width of openings, which are usually used for embarkation and disembarkation of persons with reduced mobility shall not be at less than 1.5 m.

8.7 HOISTING GEAR OF SHIPBORNE BARGES

8.7.1 The elements of the hoisting gear of the shipborne barges to be lifted by the crane on board the barge carrier (lugs, eye plates, rings, shackles, grips, etc.) shall be designed to withstand the forces resulting from lifting the shipborne barge uniformly loaded with the specification cargo and gripped in two points diagonally positioned. Under these forces the stresses in the elements of the hoisting gear shall not exceed 0,7 times the upper yield stress of material.

8.8 PILOT TRANSFER ARRANGEMENTS, MEANS OF EMBARKATION AND DISEMBARKATION

8.8.1 Ships engaged on voyages in the course of which pilots are likely to be employed shall be provided with pilot transfer arrangements. Construction and position of pilot transfer arrangements shall comply with the requirements specified in regulation V/23 of SOLAS-74, as amended (hereinafter, SOLAS), and IMO resolutions A.1045(27) and A.1108(29).

Interpretation: sub-paragraphs 1 and 2 of SOLAS regulation V/23.3.3 address two different and distinct arrangements

- the former when only a pilot ladder is used;

- the latter when a combined arrangement of "an accommodation ladder used in conjunction with the pilot ladder" is used.

1. SOLAS regulation V/23.3.3.1 limits the length of climb on a single ladder shall be not more than 9 m regardless of the trim or list of the ship.

2. SOLAS regulation V/23.3.3.2 and Section 3 of IMO resolution A.1045(27) apply to a combined arrangement of "an accommodation ladder used in conjunction with the pilot ladder" for "safe and convenient access to, and egress from, the ship" for which a 158 list requirement does not apply.

8.8.2 The construction of means of embarkation and disembarkation shall comply with the requirements of IMO circular MSC.1/Circ.1331 «Guidance on the construction, installation, maintenance and inspection/survey of means of embarkation and disembarkation».

8.8.3 Passenger ships equipped for the carriage of persons with reduced mobility shall be designed and equipped to facilitate embarkation and disembarkation of persons with reduced mobility.

The structure of the accommodation ladders and gangways of passenger ships shall comply with the requirements of the IMO Circular MSC/Circ.735 “Recommendation on the design and operation of passenger ships to respond to elderly and disabled persons' needs”.

8.8.4 Recovery of persons from the water

8.8.4.1 All vessels engaged in international voyages shall be provided with ship specific schemes and procedures for recovery of people from the water, taking into account the guidance developed by IMO (Guidelines for the development of plans and procedures for recovery of persons from the water, MSC.1/Circ.1447).

Schemes and procedures shall specify equipment intended for use in recovery, as well as measures to minimize the risk to ship personnel involved in recovery operations.

Ships constructed before 1 July 2018 shall comply with this requirement before the date of the first periodic survey or the first renewal survey to renew the ship safety equipment certificate, which is to be performed after 1 July 2018, whichever is earlier.

Passenger ships with sign **B-R3-S**, **B-R3-RS**, **C-R3-S**, **C-R3-RS**, **D-R3-S** and **D-R3-RS** constructed before 1 January 2018 shall comply with this requirement before the date of the first periodic survey or the first renewal survey to renew the ship safety equipment certificate after 1 July 2018.

8.8.4.2 Passenger ro-ro ships, shall meet the requirements of **8.8.4.1**.

8.9 NOISE, PRODUCED BY THE SHIP. NOISE PROTECTION.

8.9.1 The noise level on the ship, protection of the crew (personnel) against noise shall comply with requirements applicable to this subsection subject to the provisions of the Code on noise levels on board ships adopted by the Maritime Safety Committee by the Resolution MSC.337(91).

8.9.2 This regulation shall apply:

8.9.2.1 To ships of 1,600 gross tonnage and above:

.1 for which the building contract is placed on or after 1 July 2014; or

.2 in the absence of a building contract, the keels of which are laid or which are at a similar stage of construction on or after 1 January 2015; or

.3 the delivery of which is on or after 1 July 2018,

unless the Administration deems that compliance with a particular provision is unreasonable or impractical;

.4 Passenger ships with sign **B-R3-S**, **B-R3-RS**, **C-R3-S**, **C-R3-RS**, **D-R3-S** and **D-R3-RS** constructed on or after 1 January 2018;

unless the Administration deems that compliance with a particular provision is unreasonable or impractical.

8.9.2.2 On ships of 1,600 gross tonnage and above delivered before 1 July 2018 and:

.1 contracted for construction before 1 July 2014 and the keels of which are laid or which are at a similar stage of construction on or after 1 January 2009 but before 1 January 2015; or

.2 in the absence of a building contract, the keels of which are laid or which are at a similar stage of construction on or after 1 January 2009 but before 1 January 2015 measures shall be taken to reduce machinery noise in machinery spaces to acceptable levels as determined by the Administration. If this noise cannot be sufficiently reduced the source of excessive noise shall be suitably insulated or isolated or a refuge from noise shall be provided if the space required to be manned.

Ear protectors shall be provided for personnel required to enter such spaces, if necessary;

.3 in passenger ships with sign **B-R3-S**, **B-R3-RS**, **C-R3-S**, **C-R3-RS**, **D-R3-S** and **D-R3-RS** of 1600 gross tonnage and over, constructed on or after 1 January 2018, measures shall be taken to reduce machinery noise in machinery spaces to acceptable levels. If this noise cannot be sufficiently reduced the source of excessive noise shall be suitably insulated or isolated or a refuge from noise shall be provided if the space required to be manned.

Ear protectors shall be provided for personnel required to enter such spaces, if necessary.

8.9.3 Requirements **8.9.1** do not apply to:

- .1 dynamically supported craft*;
- .2 highspeed craft;
- .3 pleasure yachts not engaged in trade;
- .4 fishing vessels;
- .5 floating cranes, crane barges;
- .6 mobile offshore drilling units and MSP;
- .7 hopper dredgers/dredgers, dredging ships, ships for piling, pipe-laying barges, ships of the technical fleet, etc;
- .8 ships not propelled by machinery, and
- .9 passenger cabins and other passenger accommodation **, unless they are working premises and fall within the definition: «Accommodation» or «Working places».

* Dynamically supported craft (DSC) - a craft which is operable on or above water and which has characteristics different from those of conventional displacement ships.

Within the aforementioned generality, a craft which complies with either of the following characteristics:

- .1 the weight, or a significant part thereof, is balanced in one mode of operation by other than hydrostatic forces;
- .2 the ships may move at a speed at which the ratio $[V/(gL)^{0.5}] \geq 0,9$,

the craft is able to operate at speeds such that the function where V is the maximum speed;

L is the water-line length;

g is the acceleration due to gravity, all in consistent units.

** The noise level in passenger cabins and other passenger areas shall comply with the requirements of the Sanitary Standards adopted by the Flag State Administration.

8.9.4 The Flag State Administration may, in special circumstances, grant exemption from certain requirements if it is documented that their compliance is not possible, despite the implementation of appropriate technical measures to reduce noise. Such exemptions shall not apply to cabins, except in exceptional circumstances.

When granting exemption from certain requirements, it is to be ensured that the Codex objective on noise levels on ships *** is fulfilled, and the limitation of the influence of noise should be considered together with Chapter 5 of this Code.

*** Refer to IMO A.468(XII), Resolution MSC.338(91).

8.9.5 For ships designed for and employed on voyages of short duration, or on other services involving short periods of operation of the ship, sections 3 and 4 of Table 8.9.9.2 (which are applicable) may be applied only with the ship in the port condition, provided that the periods under such conditions are adequate for seafarers' rest and recreation.

8.9.6 Definitions.

For the purposes of this paragraph, in addition to the definitions and explanations specified in 1.2, Part I "Classification" and in 1.2, Part III "Equipment, arrangements and outfit", the following definitions apply:

.1 *Hearing loss* is hearing loss is evaluated in relation to a reference auditory threshold defined conventionally in ISO Standard 389-1 (1998).

The hearing loss corresponds to the difference between the auditory threshold of the subject being examined and the reference auditory threshold.

A hearing loss, originating in the nerve cells within the cochlea, attributable to the effects of sound.

Occasional exposures: those exposures typically occurring once per week, or less frequently.

Potentially hazardous noise levels those levels at and above which persons exposed to them without protection are at risk of sustaining a noise induced hearing loss.

.2 *Accommodation* are cabins, offices (for carrying out ship's business), hospitals, mess rooms, recreation rooms (such as lounges, smoke rooms, cinemas, libraries and hobbies and games rooms) and open recreation areas to be used by seafarers.

.3 *Ear protector* is a device worn to reduce the level of noise heard by the wearer.

.4 *Sound* is an energy that is transmitted by pressure waves in air or other materials and is the objective cause of the sensation of hearing.

.5 *Existing ship* – a ship which is not a new vessel.

.6 *Voyages of short duration* are voyages where the ship is not generally underway for periods long enough for seafarers to require sleep, or long off-duty periods, during the voyages.

.7 Machinery spaces for the purpose of this paragraph are any spaces containing propulsion machinery, boilers, oil fuel units, steam and internal combustion engines, generators and major electrical machinery, oil filling stations, refrigerating, stabilizing, ventilation and airconditioning machinery and similar spaces, and trunks to such spaces.

.8 Navigation spaces are navigation bridge / wheelhouse, chart room, watch stations, including wings and wheelhouse windows, radio rooms (with radio equipment operating but not generating sound signals), radar.

.9 New ship is a ship to which the requirements of this paragraph apply in accordance with **8.9.2.1**.

.10 Attended spaces are spaces requiring a permanent or prolonged presence of the crew during normal operating periods.

.11 Repair, re-equipment and modification of substantial nature means the re-equipment of the ship, resulting in a substantial change in particulars, power capacity of the ship's engine(s), change in the type of ship, other changes of the ship in such a way that, the relevant provisions would apply to it as for the new ship.

.12 Sound pressure level L_p is the level of sound pressure, expressed in decibels (dB), which is determined by the following formula:

$$L_p = 10 \log(p^2/p_0^2),$$

where: p – sound pressure, in Pa;

$p_0 = 20 \mu\text{Pa}$ (zero level).

.13 Working places are premises where the main navigation equipment, ship radio equipment or emergency source of energy are located or where the means of controlling fire extinguishing systems or fire detection alarms are concentrated, as well as premises used as galley, main refreshments, storerooms (except for isolated cupboards and cabinets), postal offices, storehouses of valuables, workshops, which are not a part of the machinery spaces and other similar premises.

.14 Port condition is the condition in which all machinery solely required for propulsion is stopped.

.15 Noise for the purpose of the Code are all sounds which can result in hearing impairment, or which can be harmful to health or be otherwise dangerous.

8.9.7 Noise produced by the ship.

8.9.7.1 Noise of the ship under way, and in particular the noise produced by the receiving and discharge openings / devices for air and gas exhaust piping / devices shall be limited by appropriate means.

The noise level produced by the ship shall not exceed 75 dB (A) at a distance of 25 m from the ship's side.

8.9.7.2 Without taking into account loading and unloading operations, the noise level produced by the ship at berth should not exceed 65 dB (A) at a distance of 25 m from the ship's side.

8.9.7.3 The noise level is taken into account only from noise sources related to the ship, such as machinery and propulsion system, but no account is taken of wind / wave / ice noise, alarms, public address systems, etc.

8.9.8 Noise protection.

8.9.8.1 Limit values of noise levels shall be set and its impact on the crew shall be reduced to:

.1 ensure safe working conditions, taking into account the need for oral negotiations and audition of sound signals in control stations, navigational spaces and their machinery spaces serviced by the crew;

.2 protect the crew from excessively high levels of noise that may induce hearing loss and

.3 provide necessary degree of comfort in the premises for rest and entertainment and other premises, as well as to provide conditions for the removal of the effects of high-level noise.

8.9.8.2 Where the noise level in machinery spaces (or other spaces) is greater than 85 dB(A), entrances to such spaces should carry a warning notice comprising symbol and supplementary sign in the working language of the ship's crew / English (refer to Fig. **8.9.8.2**).

If only a minor portion of the space has such noise levels the particular location(s) or equipment shall be identified at eye level, visible from each direction of access.

	Warning sign	Symbol
--	--------------	--------

Warning Sign (Symbol)		
Warning inscription	Warning Noise hazard zone	Ear protection must be worn

Fig. 8.9.8.2 Example of warning sign / symbol and the inscription.

The color of the warning sign field and inscription is yellow.

The color of the symbol field and inscription is blue.

8.9.9 Noise exposure limits.

.1 The limits specified in this paragraph shall be considered as maximum permissible levels, but not as desirable levels. Where practicable, it is desirable that the noise level shall be below the specified maximum permissible values.

.2 Noise exposure limits (dB (A)) for different rooms are shown in Table 8.9.9.2.

Table 8.9.9.2

Nos	Spaces	Ship dimension	
		Gross tonnage from 1600 to 10000	Gross tonnage \geq 10000
1	2	3	4
1	Working space ¹		
1.1	Machinery space ²	110	110
1.2	Machinery control stations	75	75
1.3	Workshops which not included in machinery spaces	85	85
1.4	Working spaces not specified separately (other workplaces) ³	85	85
2	Navigation facilities		
2.1	Navigation bridge and chart rooms	65	65
2.2	Radio rooms (with running but not producing audio signals radio equipment)	60	60
2.3	Radar room	65	65
3	Accommodation		
3.1	Hospital cabins and rooms ⁴	60	55
3.2	Mess rooms	65	60
3.3	Rest rooms	65	60
3.4	Open rest areas (outdoor recreation areas)	75	75
3.5	Offices	65	60
4	Service rooms		
4.1	The galley with non-working equipment for processing the products	75	75
4.2	Handouts and buffets	75	75
5	Normally unattended spaces		
5.1	Spaces with high noise levels, where the crew can be exposed to it even for relatively short periods of time, as well as the location of the machinery used periodically	90	90

¹ A limit of 110 dB (A) assumes that hearing protectors are worn to provide protection that meets the requirements for hearing protection set out in 8.9.8.

² If the maximum noise levels are exceeded during operation (only permitted in the case of an exemption in accordance with paragraph 8.9.4), being in the room shall be limited to very short periods or prohibited. This area shall be designated in accordance with 8.9.8.2.

³ For example: working places on open decks that are not machinery spaces, as well as working places on open decks, where communication is important.

⁴ Hospital: facilities for treatment provided with beds.

8.9.10 Noise resting areas.

.1 Alternatively, when designing ships with a gross tonnage of less than 1600 or icebreakers, noise resting areas may be provided.

.2 Noise resting areas shall be provided in the event that no other technical or organizational solution is possible to reduce the excessive noise produced by sound sources.

8.9.11 In the event of repair, reequipment and modification of the essential nature and associated changes in the equipment of existing ships, it shall be ensured that all areas in which the changes are made comply with the requirements of this subsection for new ships to the extent that the Flag State Administration deems practicable and feasible.

8.9.12 Tests of ships for compliance with the noise level limit requirements shall be carried out according to the program and test methodology approved by the Register in the presence of a representative of the Register.

The program and test procedures shall comply with the provisions of the Code on noise levels on board ships.

8.10 ADDITIONAL REQUIREMENTS TO STANDBY VESSELS

8.10.1 Each side shall be provided with evacuation areas (*rescue zones*) of at least 5 m in length with appropriate marking. Evacuation areas shall be spaced sufficiently from the propulsion gear, as well as from any side outlets, which are less than 2 m below the load line.

8.10.2 The sides of the vessel in the area of the rescue zones shall be free from protruding parts (fenders, etc.).

8.10.3 Spaces for the recovered.

8.10.3.1 The ship shall be fitted with a first aid room for the rescued in an emergency (treatment room), a wellness room with beds and a closed room for the rescued. These premises must be equipped with lighting and temperature and humidity controls, taking into account the possible operating area.

8.10.3.2 The space for the rescued shall be calculated at 0.75m² per person. This space includes free space, removable furniture, fixed seats and/or beds. Other stationary furniture, toilets and baths are not included in the specified area.

8.10.3.3 A toilet equipped with a shower and sink shall be provided for each 50 rescued persons.

8.10.4 Passages from rescue areas to rooms for rescued and to the helicopter winching area, if provided, shall be fitted with non-slip or wooden cover.

8.10.5 The deck within the rescue areas should be as clear as possible from obstructions (air pipes, fittings, hatches, etc.). If available, adequate protection against personnel injury should be provided.

8.10.6 The bulwark or railing in the rescue zones area shall be removable or easily opened.

8.10.7 In the area of each rescue zone, a net must be provided for recovery of rescued people from water (scrambling net), which is made of corrosion-resistant and non-slip material with a width of at least five meters and a length exceeding 1 m from the place of deployment in the rescue zone to the water line at the lowest operational draft.

8.10.8 The ship shall be fitted with machinery for the accurate recovery of rescued people with restricted mobility from the water.

8.11 ADDITIONAL REQUIREMENTS TO ANCHOR HANDLING SHIPS

8.11.1 The design loads of the anchor handling winch devices, namely: for the anchor chain stopper, tow bitens and stern rolls, shall be taken in accordance with 5.4.2.2. In this case, the stresses in these elements shall not exceed 0.8 the yield stress of their material.

8.11.2 Anchor handling winch shall be fitted with a cable tension measuring device.

9. REQUIREMENTS TO ESCORT TUGS

9.1 GENERAL APPLICATION

9.1.1 The technical requirements for escort tugs apply to tugs intended for escort service.

These requirements are additional to the relevant requirements of Parts IV "Stability", VII "Machinery Installations" and VIII "Systems and Piping".

Tugs complying with the requirements of 2.2.37 of Part I "Classification" may be assigned the descriptive notation Escort tug added to the character of classification.

9.1.2 Definitions and explanations.

9.1.2.1 Definitions have been adopted in this section, the following (in addition to those indicated in 1.2):

Escort tug means a tug which in addition to towing and ship handling operations is intended for escort services.

Full scale trials mean sea trials of the escort tug to determine escort characteristics.

Escort service means steering, braking and otherwise controlling the assisted ship.

Escort characteristics :

- maximum steering pull of the tug F_s , in t, escort test speed V , in knots, (refer to Fig. 9.1.2.1);

- maneuvering time t , in s.

Maximum steering pull of the tug means the maximum transverse steering force, in t, exerted by the tug on the stern of the assisted ship at the escort test speed of 8 and/or 10 knots.

Assisted ship means the ship being escorted by the escort tug.

Maneuvering time means a minimum manoeuvring time, in s, from maintained oblique position of the tug (from the centerline of the assisted ship) giving the maximum transverse steering force on one side of the assisted ship to mirror position on the other side.

Escort test speed means the speed, in knots, of the assisted ship during full scale trials.

9.1.3 Technical documentation.

9.1.3.1 The following technical documentation (in addition to the requirements of 4.2 and 4.3, Part I "Classification") shall be provided for the approval of the Register:

.1 towing arrangement plan required for escort service including towing line path and minimum breaking strength of towing line components and strength of appropriate structures;

.2 preliminary calculation of maximum steering pull of the tug at the escort test speed of 8 and/or 10 knots including propulsion components of the escort tug for balancing of oblique angular position of the tug.

.3 preliminary tug stability calculations for escorting service;

.4 plan of full scale trials.

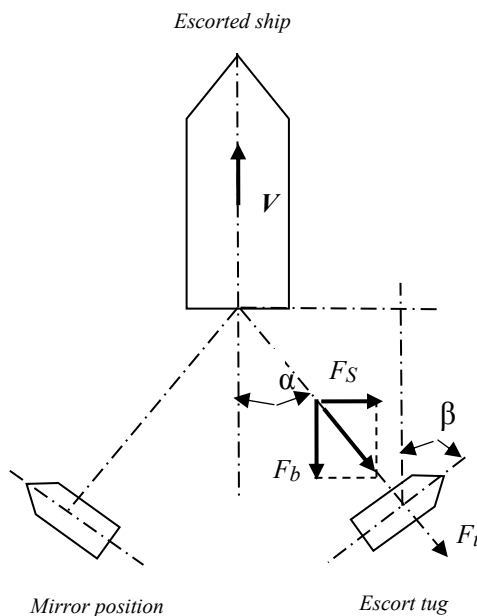

Fig. 9.1.2.1 Typical escort configuration.

F_s – steering force; F_b – braking force;

F_t – towline force; V – assisted ship speed;

α – the angle between the towline and the centreline of the escorted ship.

β – the angle between the centreline of the tug and the centreline of the escorted ship.

9.2 TECHNICAL REQUIREMENTS

9.2.1 Arrangement and design.

9.2.1.1 A bulwark shall be fitted all around the exposed weather deck.

9.2.1.2 The towing winch intended for escort service shall be fitted with a load reducing system in order to prevent overload caused by dynamic oscillation in the towing line, and shall be capable of paying out the towing line if the pull exceeds 50 per cent of the breaking strength of the towing line.

9.2.1.3 The towing line components shall have a minimum breaking strength of at least 2,2 times the maximum towing pull as measured during the full scale trials (refer to **9.3**).

9.2.1.4 In case of escort service of oil tankers and/or oil recovery vessels, supply vessels, ships intended for the carriage of explosives and inflammable cargoes, the requirements of **11.1.3**, Part VIII "Systems and Piping" shall be complied with.

9.2.2 Stability.

9.2.2.1 The escort tug shall comply with the criteria specified in **3.7.4**, Part IV "Stability".

9.3 FULL SCALE TRIALS

9.3.1 Full scale trials program.

9.3.1.1 Prior to the full scale trials the program of trials, the approved Stability Information, as well as preliminary calculations of the ship's escort characteristics and the tug's stability during escort service shall be submitted to the Register.

9.3.1.2 The program of full scale trials shall stipulate determination of the tug's maximum transverse steering force with the assisted ship speed of 8 and/or 10 knots, the maximum angle of static heel at the specified modes, as well as the tug's manoeuvring time.

9.3.1.3 The program shall include a list of measuring instruments, description of mandatory manoeuvres, a towing arrangement scheme for expected escort modes, design loads of strong points of the tug, as well as data of the safe working load of the strong points of the assisted ship.

9.3.2 Trial procedure.

9.3.2.1 The trials shall be carried out in favourable weather (recommended limitation of wind force is 10 m/s, sea state 2), with the operating load of the tug equal to 50 — 10 per cent of provisions.

Current velocity in the area of the trials (if any) shall be measured both upstream and down stream.

9.3.2.2 Displacement of the assisted ship shall be sufficient to maintain the heading and speed with the help of the autopilot during the necessary tug manoeuvring.

9.3.2.3 The following data shall be recorded continuously in real time mode during trials for later analysis:

.1 position of the assisted ship in relation to the escort tug;

.2 towing line tension;

.3 escort test speed;

.4 angle of the tug heel during escort service;

.5 length and angle of the towing line from the centerline of the assisted ship;

.6 manoeuvring time from maintained oblique position of the tug on one side of the assisted ship to mirror position on the other side at the maximum tension value of towing line and the maximum towing line angle from the centerline of the assisted ship (but not more than 60°);

.7 angle of heel due to sudden loss of thrust.

10. REQUIREMENTS FOR THE EQUIPMENT OF SHIPS WITH ICING PROTECTION

10.1 GENERAL. APPLICATION

10.1.1 The requirements for the equipment of ships with icing protection apply to ships the design and equipment of which provide effective icing protection.

These requirements are additional to the requirements of Part VIII "Systems and Piping" and Part XI "Electrical Equipment" of these Rules, as well as Chapters III, IV, V of International Convention for the Safety of Life at Sea, 1974 (SOLAS 74), as amended by 1978 Protocol, 1988 Protocol relating there to with further amendments (SOLAS 74/78/88) and the Convention on the International Regulations for Preventing Collisions at Sea, 1972 (COLREG 72) .

10.1.2 Ships complying with the requirements of the present Section may be assigned with the distinguishing mark **DEICE** added to the character of classification in accordance with **2.2.13**, Part I "Classification".

10.1.3 Definitions and explanations.

10.1.3.1 For the purpose of the present Section the following definitions and explanations have been

adopted (in addition to adopted in 1.2:

De-icing is removal of ice appearing on the ship's hull, structures and equipment.

Icing protection is a set of design and organizational measures aimed at reduction of the ship's icing and reduction of labour input into ice removal during operation of the ship.

Anti-icing is prevention of ice formation on the ship's structures and equipment by means of their heating or relevant covering.

Icing is a process of ice accretion on the ship's hull, structures and equipment due to sea water splashes or freezing of moisture condensing on the hull from the atmosphere.

Icing Protection Manual is a document describing actions of the ship's crew to provide icing protection. The scope of the Manual (content) depend on the ship's type, purpose and area of navigation; they shall be chosen in the most efficient way and agreed with the Register.

10.1.4 Technical documentation.

10.1.4.1 The following technical documentation shall be submitted to the Register for approval (in addition to required in 4.2 and 4.3 Part I "Classification") to assign the distinguishing mark **DEICE** in the class notation:

- .1 arrangement plan of anti-icing means with indication of their heating capacity;
- .2 calculation of heating capacity of anti-icing systems equipment;
- .3 electrical single-line diagram of anti-icing systems with heating cables (if any);
- .4 circuit diagram of steam and/or thermal liquids anti-icing systems (if any);
- .5 arrangement diagram of de-icing means;
- .6 test program for anti-icing systems.

10.1.4.2 Icing Protection Manual approved by the Register shall be kept onboard.

10.2 TECHNICAL REQUIREMENTS FOR ASSIGNING THE DISTINGUISHING MARK DEICE IN THE CLASS NOTATION

10.2.1 Ships with the distinguishing mark **DEICE** in the class notation shall, as a rule, be fitted with a tank of a shape providing effective water flow under all operating loading cases.

Assignment of the distinguishing mark **DEICE** in the class notation to flush deck ships is subject to special consideration by the Register in each particular case.

10.2.2 The following anti-icing means may be used:

- .1 heating of structures and equipment by means of steam, thermal liquid or heating cables;
- .2 use of permanent (awnings, casings) or removable (covers) protective covers;
- .3 the use of lattice structures for platforms, steps of external gangways, walkways, etc.

10.2.3 The following de-icing means may be used besides heating of structures:

- .1 washing and firing of ice by means of hot water or steam;
- .2 anti-icing liquids;
- .3 manual mechanical means including pneumatic instrument.

10.2.4 If steam systems are used for anti-icing the requirements of Section 18, Part VIII "Systems and Piping" shall be complied with.

10.2.5 If thermal liquid systems are used for antiicing the requirements of Section 20, Part VIII "Systems and Piping" shall be complied with.

10.2.6 If systems with heating cables are used for anti-icing the requirements of 15.4, Part XI "Electrical Equipment" shall be complied with.

10.3 EQUIPMENT, ARRANGEMENTS AND OUTFIT

10.3.1 Platforms of outer ladders as well as platforms for servicing arrangements and equipment fitted on open decks shall have a grid structure or be equipped with heating elements.

10.3.2 Outer ladders located on the escape routes to life-saving appliances as well as muster stations to lifesaving appliances (including guard rails) shall be equipped with anti-icing means.

10.3.3 Coamings of outer doors leading to the accommodation superstructure spaces and to spaces providing the ship's operation in accordance with its main purpose shall be heated.

Decks in areas of exit from the said spaces shall be equipped with anti-icing means.

10.3.4 A passage from the accommodation superstructure spaces to the equipment fitted in the fore part of the ship shall be provided on tankers, including chemical tankers and gas carriers. This passage shall be

provided with anti-icing means.

10.3.5 Side scuttles in the wheelhouse providing the arc of visibility required by Chapter V of International Convention for the Safety of Life at Sea, 1974 (SOLAS 74), as amended by 1978 Protocol, 1988 Protocol relating thereto with further amendments (SOLAS 74/78/88) according to the ship's class shall be heated.

Windshield wipers on the said side scuttles (if any) shall be heated as well.

These requirements also apply to side scuttles in cargo operations control stations.

10.3.6 Shell doors, cargo doors and other closing appliances in the fore part of the ship providing the ship's operation in accordance with its main purpose shall be fitted with means for effective ice removal or other means to provide working capacity of the said appliances in case of icing (for example, with ice-breaking hydraulic cylinders).

10.3.7 Design of packing of cargo hatches, shell doors and other closing appliances providing the ship's operation in accordance with its main purpose shall preclude freezing of condensate inside seals.

10.3.8 Anti-icing shall be provided for the following arrangements and equipment:

.1 anchor and mooring equipment including (but not limited to) winches, capstans, windlasses, chain stoppers, drums, control panels;

.2 arrangements for emergency towing of tankers, including chemical tankers and gas carriers;

.3 hook releasing devices of lifeboats;

.4 launching appliances of survival craft (falls on drums, sheaves, winches of launching appliances, winch breaks and other elements engaged in launching);

.5 life rafts, including hydrostatic releasing devices. The Register may require taking measures to prevent icing of additional equipment and arrangements in accordance with the ship's main purpose.

10.3.9 Lifeboats shall be of enclosed type and be equipped with the relevant heating elements to prevent icing and blocking of access hatches and/or doors.

10.3.10 Proper locations shall be provided on board for at-sea storage of removable covers used to prevent icing of equipment and fittings.

10.3.11 In addition to the emergency outfit specified in Section 12, ships with the distinguishing mark **DEICE** in the class notation shall have the necessary de-icing outfit (crowbars, ice-axes, axes, shovels, spades) kept in places of permanent storage and having the relevant marking.

10.4 SYSTEMS AND PIPING

10.4.1 Sufficient number of scuppers and freeing ports shall be provided for the effective water flow from open decks.

Scuppers and freeing ports shall be located so as to preclude water stagnation on decks under all operating loading cases.

10.4.2 Air heads of ballast tanks and fresh water tanks shall be fitted with the relevant heating devices.

10.4.3 Design of air intakes of main, auxiliary and emergency power plants as well as of ventilation of spaces, which are of great importance for the ship's safety, shall preclude their icing that may cause air duct blockage.

10.4.4 Measures shall be taken to preclude freezing of liquid in the pipelines of fire extinguishing systems by means of their effective drying or heating.

Fire hydrants, monitors, valves and other equipment of fire extinguishing systems fitted on open decks shall be protected from icing by means of heating or removable covers.

Cut-off valve of water and foam fire extinguishing systems shall be fitted in enclosed heated spaces or shall be heated.

10.4.5 Hot water or steam supply shall be provided for de-icing on weather decks.

10.4.6 In addition to **10.4.1** ÷ **10.4.5**, the following items shall be heated on tankers, including chemical tankers and gas carriers:

.1 ventilation valves and pressure/vacuum valves (PA/ valves) of cargo tanks and secondary barriers;

.2 level, pressure, temperature gauges and gas analysers in cargo tanks located on open decks, if necessary;

.3 inert gas system elements containing water and located on open decks;

.4 emergency shut-down system (ESD) on gas carriers.

10.4.7 Drives of remotely operated fittings of tankers, including chemical tankers and gas carriers, fitted on open decks shall be equipped with anti-icing devices.

10.4.8 Pipelines equipped with electrical heating shall comply with the requirements of **5.8**, Part VIII "Systems and Piping".

10.5 ELECTRICAL EQUIPMENT, SIGNAL MEANS, RADIO AND NAVIGATIONAL EQUIPMENT

10.5.1 The following electrical equipment, signal means, radio and navigational equipment located on open decks shall be designed so that to prevent icing or shall be heated:

- .1 aerials of radio and navigational equipment (excluding rod aerials), aerial matching devices (if fitted on open decks);
- .2 navigation lights;
- .3 whistles;
- .4 satellite emergency position indicating radio beacons;
- .5 main and emergency lighting of open decks;
- .6 TV cameras used during operation of the ship in accordance with its main purpose;
- .7 aerials of telemetric and dynamic positioning systems;
- .8 means (buttons) for the remote stop of pumps for the discharge of oil-containing and waste water to reception facilities.

10.5.2 If consumers, which according to 9.3.1, Part XI "Electrical Equipment" shall be supplied from the emergency source of electrical power, are fitted with electrical heating, their heating elements shall be also fed from the emergency source of electrical power.

10.6 TESTING

10.6.1 Prior to testing an Ice Protection Manual (only for ships without the additional distinguishing mark **WINTERIZATION (DAT)** in class notation) shall be submitted to the Register.

10.6.2 Anti-icing means are tested with a demonstration of their intended use and taking measurements of heat output.

11. REQUIREMENTS FOR HELICOPTER FACILITIES

11.1 GENERAL. APPLICATION

11.1.1 Requirements for helicopter facilities are additional to those of Part I "Classification", Part II "Hull", Part VI "Fire Protection", Part VIII "Systems and Piping", Part XI "Electrical Equipment" of those Rules as well as Chapter IV of International Convention for the Safety of Life at Sea, 1974 (SOLAS 74), as amended by 1978 Protocol, 1988 Protocol relating there to with further amendments (SOLAS 74/78/88).

Passenger roller ships (ro-ro passenger ships) with a length of 130 m or more with a sign **A, A-R1, A-R2, A-R2-RS, A-R2-S, B-R3-S, B-R3-RS, C-R3-S, C-R3-RS, D-R3-S, D-R3-RS** in the character of classification, shall be fitted with helicopter decks complying with requirements of these Rule.

11.1.2 Ships that meet the requirements of this section, in accordance with **2.2.25**, Part I «Classification», may be assigned with the following distinguishing marks added to the character of classification:

.1 HELIDECK –for ships fitted with helidecks and complying with the requirements specified in **11.2, 11.3, 11.6, 11.7** and **6.1.1** Part IV “Fire Protection”;

.2 HELIDECK-F – for ships fitted with the helicopter refuelling facilities, in addition to those of **11.1.2.1**, complying with the requirements specified in **11.5.1, 11.5.2** (as applicable) and **6.1.2** (as applicable), Part IV “ Fire Protection ”;

.3 HELIDECK - H – – for ships fitted with a hangar and complying with the requirements of the present Section in a full scope..

11.1.3 All ro-ro passenger ships shall be provided with a place for picking up on board the helicopter.

Passenger ro-ro ships of 130 m in length and over shall be fitted with a helicopter landing area.

Ships shall also meet the requirements of the International Civil Aviation Organization (ICAO) and the Flag State (if any) for the safe operation of helicopters, which shall be confirmed by the relevant conclusion or Certificate of the competent civil aviation authority.

11.1.4 Definitions.

11.1.4.1 For the purpose of the present Section the following definitions and explanations have been adopted (in addition to adopted in 1.2):

H a n g a r is a purpose-built space for helicopter storage and/or maintenance and repair.

Helicopter is the largest ship's helicopter, for which a safe take-off and landing operation on board a ship is ensured.

Helideck is a purpose-built helicopter take-off and landing area including all structures, fire-fighting appliances and other equipment necessary for the safe operation of helicopters.

Helicopter facility (helicopter facility) is a complex of technical means including a helideck, helicopter refuelling facilities and compressed gas or special liquid filling facilities (if any), as well as hangars and spaces where helicopter maintenance facilities are located (if any).

Final approach and take-off area (final approach and take-off area, FATO) is the area over which the propeller completes the landing approach maneuver, ending with the transition to the hovering or landing mode, or when performing the maneuver of the take-off begins a progressive flight.

Touchdown and lift-off area (TLOF) (touchdown and lift-off area, TLOF) is a dynamic loadbearing area on which a helicopter may touchdown or lift off. For a helideck it is presumed that the FATO and the TLOF will be coincidental.

Helicopter landing area is an area on a ship designated for occasional or emergency landing of helicopters but not designed for routine helicopter operations.

Winching area is a pick-up area provided for the transfer by helicopter of personnel or stores to or from the ship, while the helicopter hovers above the deck.

11.1.5 Technical documentation.

10.1.5.1 The following technical documentation shall be submitted to the Register for approval (as applicable) to assign distinguishing marks **HELIDECK-F**, **HELIDECK-H** or **HELIDECK**, in the class notation (in addition to required in 4.2 and 4.3, Part I "Classification"):

- .1 helideck and hangar deck plans with indication of design loads;
- .2 scantlings determination of helideck and hangar deck, as well as of deck and bulkhead stiffeners in way of helicopter tie-down points;
- .3 general arrangement plan of a helicopter facility elements with indication of escape routes, tie-down points, location of fire-fighting equipment and lifesaving appliances, arrangement plan and specification of lighting and illumination means;
- .4 drawing of helideck safety net;
- .5 diagram of power driving gear for the helideck safety net hoisting and lowering, if any;
- .6 diagram of helideck drainage system;
- .7 diagram of fuel oil loading, transfer, storage and helicopter refuelling system;
- .8 diagram of off-grade aviation fuel collection, storage and defueling system;
- .9 diagram of nitrogen system for aviation fuel;
- .10 electric diagram of main and emergency lighting in the spaces of helicopter facility arrangement;
- .11 circuit diagram of helideck lighting and illumination means;
- .12 drawings of electrical equipment layout and cable laying on the helideck, in hangar and in other spaces of helicopter facility arrangement;
- .13 documentation on helideck and hangar deck covering;
- .14 helicopter facility test program;
- .15 diagram of obstacle restriction and removal approved by the Flag State Civil Aviation Authority (to be submitted for information);
- .16 drawing of helideck and obstacle marking (colour, dimensions and configuration of marks shall be indicated), approved by the Flag State Civil Aviation Authority (to be submitted for information).

11.1.5.2 A Manual for the operation of helicopter maintenance facilities (hereinafter referred to as the Manual), including a description of the equipment, a list of control checks, safety requirements and equipment maintenance procedures shall be provided on board ships. This Manual shall also include procedures and safeguards to be followed during fueling operations of helicopters designed in accordance with recognized safe practices.

11.1.5.3 The Register may require additional documents to those listed in 11.1.5.1 proceeding from the ship design features.

11.2 HELIDECK DESIGN

11.2.1 Helideck arrangement with regard to provision of horizontal and vertical sectors for helicopter approach, landing and take-off shall comply with the requirements of ICAO and the Flag State (if any).

11.2.2 Helideck arrangement shall provide:

- .1 free helicopter approach to helideck according to **11.2.2**;
- .2 safety of helicopter take-off and landing operations and maintenance personnel;
- .3 helideck location at a maximum possible distance from the ship's hazardous spaces and areas.

11.2.3 Helideck may have any configuration in plan view, generally, circle or regular polygon. In any case FATO shall be of sufficient size to contain an area within which can be drawn a circle of diameter not less than D of the largest helicopter the helideck is intended to serve, where D is the largest dimension of the helicopter when the main and tail rotors are turning.

11.2.4 The helideck shall be provided with both main and emergency means of escape and access for firefighting and rescue personnel. These shall be located as far apart from each other as practicable, and preferably on the opposite sides of the helideck. If more than 50 per cent of the helideck area is projected from the main ship structure, it is recommended to arrange two entrances to helideck within the range of such overhanging parts that is providing at least one exit from helideck to windward side in case of fire.

11.2.5 If the helideck forms the ceiling of a deckhouse or superstructure it shall be of "A-60" class.

11.2.6 Helideck shall be made of steel. Aluminum alloys may be used provided the following:

.1 a helideck, irrespective of its type and location, shall be subject to a survey in case of fire on the helideck or in close proximity;

.2 if a helideck is located above the deckhouse or similar structure, the following conditions shall be additionally satisfied:

.2.1 the deckhouse top and bulkheads below the helideck shall have no openings;

.2.2 windows below the helideck shall be provided with steel covers;

.3 surfaces of the steel and aluminium alloy structures contacting at the point of connection and exposed to sea water shall be separated by gaskets made of nonabsorbent electrically insulating material.

Bolts, nuts and washers connecting the steel and aluminium structures shall be made of stainless steel. Bolts shall be installed in the bushes made of nonabsorbent electrically insulating material which structure shall exclude the contact of aluminium alloy and steel.

The aluminium alloy structure insulated from the steel structure shall be grounded to the ship's hull;

.4 bimetal materials shall be approved by the Register, and certificates shall be issued for them by the Register.

The horizontal component is assumed to be equal to half the vertical component;

.5 bimetallic materials shall be approved and have Certificates of the Register.

11.2.7 Helidecks and helicopter refuelling areas shall be clearly marked and provided with coamings and/or gutters to prevent fuel oil leakage from spreading.

Drainage facilities in way of helidecks shall be constructed of steel or other arrangements providing equivalent fire safety; lead directly overboard independent of any other system; and designed so that drainage does not fall onto any part of the unit.

11.2.8 Helideck plates and supporting structures shall comply with the requirements of **2.12.6**, Part II "Hull".

11.3 EQUIPMENT OF HELIDECKS

11.3.1 The helideck surface shall be smooth, no steps or recesses in FATO are generally allowed. As an exception, the steps on the FATO perimeter line (outside the helideck white perimeter line) shall not exceed 250 mm in height, and within the FATO (within the helideck white perimeter line) shall not exceed 25 mm in height.

Objects the function of which requires that they be located on the helideck within the FATO shall only be present provided they do not cause a hazard to helicopter operations.

As an exception, for ships which keels are laid before 1 January 2012, the steps within the FATO of height not exceeding 60 mm with the edge slop 1/3 are allowed.

11.3.2 The helideck, including its marking, and hangar deck shall have a skid-resistant surface.

11.3.3 For helicopter operation in winter period easily detachable rope net, rather of natural fiber (sisal), diameter of 20 mm and maximum mesh dimensions 200 x 200 mm, shall be provided along the perimeter of the FATO.

Recommended dimensions of the net, depending on the overall helicopter length, are determined by sufficiency to cover the landing area:

6 x 6 m at helicopter length less than 15 m;

12 x 12 m at helicopter length from 15 to 20 m;

15 x 15 m at helicopter length more than 20 m.

The net shall be reliably secured to the deck along the FATO perimeter and fixed to it in any 1,5 m and shall be tightened with a load not less than 2225 N.

The dismounted net shall be kept onboard.

11.3.4 Outboard edges of the helideck shall be provided with fixed or hinged safety net of at least 1,5 m in width, made of fire-resistant flexible material.

For sea-going ships, which keels are laid before 1 January 2012, outboard edge of the fixed safety net shall not rise above the plane of FATO more than 0,25 m, and the net shall be inclined upwards at an angle of at least 10°.

For sea-going ships, which keels are laid on and after 1 January 2012, outboard edge of the fixed safety net shall not rise above the plane of FATO, and the net shall be inclined upwards at an angle of at least 10°.

Hinged safety net in tumble position shall comply with the same requirements.

The safety net shall be strong enough to withstand, without damage, a 75 kg mass being dropped, and the net shall provide hammock effect for person falling into it rather than the trampoline effect produced by some rigid materials.

11.3.5 In addition to the requirements of 11.3.4 the hinged safety net shall comply with the following requirements:

.1 safety net shall be reliably secured in a hoist position;

.2 safety net shall be reliably fixed in a hinged position so as to prevent its hoist due to the effect of airflow from the helicopter rotor;

.3 safety net hoisting and lowering shall be performed so as to minimize the risk of personnel falling overboard during the operations;

.4 any failure of power driving gear for safety net hoisting shall not prevent from its lowering by hand.

11.3.6 To minimize the risk of personnel or equipment sliding from the helideck, the outboard edges of the helideck shall have coamings of recommended height of 50 mm.

The coamings shall also meet the requirements of **11.2.7**.

11.3.7 The helideck in way of helicopter parking place and maintenance areas, as well as the hangar (if any) shall be equipped with the tie-down points and means for fastening of helicopter maintenance facilities (if any), flush type is preferable.

Connection dimensions, arrangement plan and design forces of tie-down points shall be selected for fastening of one or several types of helicopter taking into account the requirements of **11.3.1**.

11.3.8 Where handrails associated with access/escape points exceed the elevation of the FATO by more than 0,25 m, they shall be made collapsible and removable. They shall be collapsed or removed whilst helicopter manoeuvres are in progress.

11.4 FIRE PROTECTION

11.4.1 Fire protection of Helideck, hangars and premises where the equipment for refueling and maintenance of helicopters is located, shall be arranged in accordance with **6.1**, Part IV "Fire Protection".

11.5 SYSTEMS AND PIPING

11.5.1 Helicopter refuelling systems.

11.5.1.1 All the equipment used in refuelling operations shall be effectively earthed.

All the equipment, arrangements, machinery and deck coverings shall be manufactured and installed so as to prevent spark formation.

11.5.1.2 Tanks used for storage of helicopter fuel shall be located on the open deck in specially designed area, which shall be:

.1 as remote as practicable from accommodation and machinery spaces, escape routes and embarkation stations, as well as from locations containing sources of ignition;

.2 isolated from areas containing sources of vapour ignition;

.3 the fuel storage area shall be provided with arrangements whereby fuel spillage may be collected and drained to off-grade fuel tank;

.4 where tanks for storage of helicopter fuel and offgrade fuel tanks are located in enclosed spaces, such tanks shall be surrounded by cofferdams filled with inert gas;

.5 in cofferdams referred to in **11.5.1.2.4** the length of oil fuel line and the number of its detachable joints shall be kept to a minimum, and its valves shall be located in easily accessible places, generally, on the open deck;

.6 cofferdams referred to in **11.5.1.2.4** shall not be connected to any piping system serving other spaces.

11.5.1.3 Helicopter fuel tanks and equipment related to them shall be protected from mechanical damage and fire in adjacent rooms or area.

Tanks shall be protected from direct sunlight.

11.5.1.4 When equipping tanks for the storage of helicopter fuel with facilities for their emergency jettisoning precautions shall be taken to prevent the tank jettisoned from impact against ship's structures. The tanks shall be as remote as practicable from survival craft muster and embarkation stations and survival craft launching stations.

11.5.1.5 If transported fuel tanks are used, their construction, fitting and securing devices shall be designed taking into account the purpose of the tank and the feasibility of its inspections.

Electrical earthing of tanks shall be provided.

11.5.1.6 Helicopter refueling system shall comply with the requirements of **13.13**, Part VIII "Systems and Piping".

11.5.1.7 The fuel tanks shall be made of materials which resist attacks by corrosion and helicopter fuel. Fuel may be stored both in transported and fixed tanks.

Tanks shall be efficiently secured, closed and bonded.

The tanks shall be readily accessible for inspection.

Tanks and piping for anticrystallization fluids shall be made of stainless steels.

11.5.1.8 The operating manual for helicopter maintenance facilities, including equipment description, a checklist, safety requirements and equipment maintenance procedures, shall be provided on board.

This manual shall also include the procedures and precautions to be followed during the helicopter fueling operations developed in accordance with recognized safe practice.

11.5.2 Ventilation system of hangars and spaces where helicopter refuelling and maintenance facilities are located.

11.5.2.1 Ventilation system of hangars and spaces where helicopter refuelling and maintenance facilities are located shall meet the requirements of **12.11**, Part VIII "Systems and Piping".

11.6 ELECTRICAL EQUIPMENT

11.6.1 Electrical equipment and electric wiring of hangars and spaces where helicopter refuelling and maintenance facilities are located shall comply with the requirements of **2.9**, Part XI "Electrical Equipment".

11.6.2 Lighting and illumination means for helidecks shall comply with the requirements of **6.9**, Part XI "Electrical Equipment" of the Rules for the Classification and Construction of Sea-Going Ships and the Flag State Civil Aviation requirements.

11.7 COMMUNICATIONS

11.7.1 To ensure helicopter operation the ship shall be equipped with necessary radio and meteorological equipment in compliance with the Flag State Civil Aviation requirements.

11.7.2 To ensure three-way communication between the helicopter, Helicopter deck and wheelhouse, the required number of portable VHF radio-telephone stations with headphones shall be provided.

11.8 TESTING

11.8.1 All systems and components of the helicopter facilities, after their installation on the ship, shall be tested in accordance with the Register approved Program.

11.8.2 On ships, upon request of the civil aviation authorities of the Flag State, flight tests and overflights may be carried out in accordance with the guidance documents of the Flag State.

12. EQUIPMENT OF SHIPS INTENDED TO FORM A PART OF OF A PUSHED CONVOY

12.1 GENERAL

The requirements of this section apply to tugboats-pushers, pushed barges of all purposes, of mixed "sea - river" navigation, which have a sign **R3-RS** in the class notation.

Tugboats-pushers and pushed barges, shall comply with the requirements of 3.17, Part II "Hull" and Directive (EU) 2016/1629 (ES-TRIN) with amendments.

The anchor gear of the pusher shall comply with the characteristics of provision in accordance with 3.2 (refer also to 3.7).

13. REQUIREMENTS FOR THE EQUIPMENT OF SHIPS TO PROVIDE DURABLE OPERATION AT LOW TEMPERATURES

13.1 GENERAL

13.1.1 Application.

13.1.1.1 Requirements for the equipment of ships to ensure long-term operation at low temperatures apply to ships designed for operation in cold climatic conditions (refer to 2.2.3.1.4 of Part I "Classification"), and are additional to the requirements of Part I "Classification", Part II "Hull", Part VII "Machinery installations", Part VIII "Systems and piping", Part IX "Machinery", part XI "Electrical equipment" and part XIII "Materials" of these Rules, as well as Chapter III, IV, V of International Convention for the Safety of Life at Sea, 1974 (SOLAS 74), as amended by 1978 Protocol, 1988 Protocol relating thereto with further amendments (SOLAS 74/78/88) and Cargo Gear Survey VRS-TWP-ST-005.

13.1.1.2 Ships complying with the specified requirements and the requirements of this Chapter, at the request of the ship-owner, a distinguishing mark **WINTERIZATION (DAT)** may be added to the character of classification (refer to 2.2.30, Part I "Classification").

13.1.2 Definitions, explanations and abbreviations.

For the purpose of the present Section the following definitions, explanations and abbreviations have been adopted.

Accommodation are spaces complying with the requirements of 1.5.2, Part VI "Fire protection".

Pollutant is any substance that is subject to restrictions on discharge into the sea in accordance with MARPOL 73/78.

Enclosed space is a space with access to an open deck and fitted with appropriate closure.

IBC Code is the International Code for the Construction and Equipment of Ships Carrying Dangerous Chemicals in Bulk.

LSA Code is the International Life-saving appliance Code.

MARPOL 73/78 is the International Convention for the Prevention of Pollution from Ships 1973 as amended by the Protocol 1978 .

Open space is a space with access to an open deck, which is not and fitted with closure or must be open for a long time under the operating conditions of the equipment installed in this space.

Design Ambient Temperature, DAT is an outdoor temperature in degrees Celsius, which is used as a criterion for the selection and testing of materials and equipment that are exposed to low temperatures.

Design Structural Temperature is a temperature in degrees Celsius, which is accepted for the choice of structural material. If there are no additional instructions in the Rules or in this section regarding the design temperature of the structure, the design ambient temperature is adopted.

Operating fluids are fuel and lubricating fluids and hydraulic oils, with the exception of marine fuels necessary for the normal operation of the ship and her equipment.

Harmful liquid substance (HLS) – any substance listed in the pollutant category column of Chapter 17 or 18 of the International Bulk Chemical or provisionally assessed in accordance with the provisions of Appendix I of Annex II to MARPOL 73/78 relating to Category X, Y or Z.

13.2 DESIGN AMBIENT TEMPERATURES

13.2.1 The design ambient temperature is set by the ship-owner based on the purpose of the ship and her operating conditions.

13.2.2 The following standard values for the design ambient temperature are provided in this section:

-30°C (distinguishing mark **WINTERIZATION(-30)**);

-40°C (distinguishing mark **WINTERIZATION(-40)**); and

-50°C (distinguishing mark **WINTERIZATION(-50)**).

The application of the requirements of this section for design ambient temperature above -30° C, as well

as for intermediate values, is determined by the Register in agreement with the ship-owner.

13.2.3 Design ambient temperature cannot be accepted higher than specified in 1.2.3.3, Part II “Hull” for the corresponding ice class of the ship.

13.2.4 Design structural temperature shall be adopted in accordance with 1.2.3.4, Part II “Hull”. In this case, design ambient temperature should be taken as the T_A value.

13.2.5 For the equipment and machinery installed on open decks, as well as in open spaces, the design ambient temperature shall be taken as the design structural temperature. For the equipment and machinery installed in enclosed spaces that are not heated and bordering the external environment and adjacent enclosed unheated spaces the design ambient temperature shall be taken as the design structural temperature.

For the equipment and machinery installed in enclosed unheated rooms bordering the external environment and adjacent to enclosed heated spaces, the temperature 20° C higher than the design ambient temperature shall be taken as the design structural temperature.

13.3 GENERAL REQUIREMENTS

13.3.1 Cargo and slop tanks of tankers with a deadweight of less than 5000 tons over the entire length shall be protected by ballast tanks or compartments not intended for the transport of pollutants, located in accordance with the requirements of regulation **19.6.1** (from the bottom plating) and the requirements for distance w of regulation **19.6.2** (from the shell plating) Annex I to MARPOL 73/78.

In ships other than tankers, all cargo tanks designed and intended to carry oil shall be located at a distance of at least 0.76 m from the shell plating.

On type 3 chemical carriers specified in 2.1.2 of the International Code for the Construction and Equipment of Ships Carrying Dangerous Chemicals in Bulk (IBC Code), or on bulk ships for the carriage of HLS cargo tanks shall be located at a distance of at least 0.76 m from the shell plating.

13.3.2 For ships with a total fuel tank capacity of less than 600m³, all fuel tanks shall be located at a distance of at least 0.76m from the shell plating. This requirement does not apply to small fuel tanks, the capacity of which does not exceed 30m³.

13.3.3 All tanks of oil residues (oil-containing sediments), tanks for the storage of operating fluids, as well as tanks of oil-containing bilge water shall be located at a distance of at least 0.76 m from the shell plating. This requirement does not apply to small fuel tanks, the capacity of which does not exceed 30m³.

13.3.4 In addition to the requirements of MARPOL 73/78 Annex I, each ship shall be equipped with a collecting tank (s) for oil residues (sludge), as well as a collecting tank (s) for oil-containing bilge water of sufficient capacity, as agreed with the Register for the complete storage on board ship of accumulated oil residues (oily sediments) and oily bilge water during the voyage in polar waters and their discharge to reception facilities.

13.3.5 Navigating bridge wings shall be enclosed.

The viewing angles shall comply with the requirements of the Regulation 22 “Navigation Bridge Visibility” Chapter V of International Convention for the Safety of Life at Sea, 1974 (SOLAS 74), as amended by 1978 Protocol, 1988 Protocol relating thereto with further amendments (SOLAS 74/78/88). The windows of the front, rear and side windows of the bridge (including wings) shall be tilted outwards from the vertical plane to an angle of not less than 10 ° and not more than 25 ° (except for the door glass).

13.3.6 Exit from the accommodation corridors to the open deck shall be arranged through heated tambours.

13.3.7 A heated deck house shall be provided to cover the crew when performing such functions as monitoring the environment during the movement of the ship or guarding the gangway while in port.

13.4 EQUIPMENT, ARRANGEMENT AND OUTFIT

13.4.1 Anchor gear.

13.4.1.1 Anchor materials shall comply with the requirements of **8**, Part XIII “Materials”.

13.4.1.2 Anchor chain cables materials shall comply with the requirements of **11**, Part XIII «Materials».

13.4.1.3 Casting materials for the manufacture of anchor fairleads shall comply with the requirements of **11**, Part XIII «Materials».

The Register documents that are issued for anchor fairleads, installed on ships with the distinguishing marks **WINTERIZATION (-40)** and **WINTERIZATION (-50)**, shall indicate the permissibility of their use at the corresponding design ambient temperature.

13.4.1.4 Anchor chain stoppers comply with the requirements of **3.6.1** of this Part.

The Register documents that are issued for anchor chain stoppers, installed on ships with the distinguishing marks **WINTERIZATION (-40)** and **WINTERIZATION (-50)**, shall indicate the permissibility of their use at the corresponding design ambient temperature.

13.4.2 Mooring gear.

13.4.2.1 Casting materials for the manufacture of bollards, roller chocks and other mooring equipment shall comply with the requirements of **11**, Part XIII «Materials».

The Register documents that are issued for mooring gear, installed on ships with the distinguishing marks **WINTERIZATION (-40)** and **WINTERIZATION (-50)**, shall indicate the permissibility of their use at the corresponding design ambient temperature.

13.4.2.2 Chain stoppers for single point mooring to offshore terminals shall meet the requirements **14.4.1.4**.

13.4.3 Towing gear.

13.4.3.1 Casting materials for the manufacture of bits, bollards, roller chocks, towing roller fairlead and other towing equipment shall comply with the requirements of **11**, Part XIII «Materials».

The Register documents that are issued for towing gear, installed on ships with the distinguishing marks **WINTERIZATION (-40)** and **WINTERIZATION (-50)**, shall indicate the permissibility of their use at the corresponding design ambient temperature.

13.4.3.2 Emergency towing gear chains shall comply with the requirements of **11**, Part XIII «Materials».

13.4.4 Side scuttles.

13.4.4.1 The side scuttles of the wheelhouse and the cargo operations control station shall be heated in accordance with **10.3.5**.

13.4.4.2 In ships with the distinguishing marks **WINTERIZATION(-40)** and **WINTERIZATION(-50)** double-glazed side scuttles shall be installed in the accommodation.

13.4.4.3 If a view onto the cargo deck is provided through the side scuttles of the Master's cabin, at least one of these side scuttles shall be heated.

13.4.4.4 External access or other equivalent means for cleaning of the bridge and the cargo control station side scuttles shall be provided.

13.4.5 Cargo hatches, shell doors, cargo doors.

13.4.5.1 Materials for the manufacture of cargo holds hatches covers and bulk cargo compartments, shell and cargo doors, including packing, shall comply with the requirements of **11**, Part XIII «Materials».

13.4.5.2 Hydraulic fluids and lubricating oils shall be suitable for use at design ambient temperature.

13.4.5.3 The Register documents that are issued for hatch covers of cargo holds and bulk cargo compartments, shell and cargo doors, installed on ships with the distinguishing marks **WINTERIZATION (-40)** and **WINTERIZATION (-50)**, shall indicate the permissibility of their use at the corresponding design ambient temperature.

14. MANEUVERABILITY

14.1 GENERAL

14.1.1 This section of the Rules sets out the basic minimum requirements for the maneuverability of ships and convoys.

In cases where the convoy consists, for example, of several vessels or of a pusher with one or more barges, the maneuverability requirements apply to the convoy in general according to **2.1.1**.

14.1.2 Ships shall be able to maneuver, that is, be able to change direction and speed quickly, ensuring the safety of navigation or solving operational tasks, both in inland waterways (not offshore) and in sea areas corresponding to the sign of the area restriction in the ship's character of class.

14.1.3 Ships longer than 100 m, and gas and chemical carriers, regardless of the length, shall be maneuverable, complying with the provisions of IMO Resolution MSC.137 (76) "Standards for ship manoeuvrability", taking into account MSC / Circ.1053 "Explanatory notes to the Standards for shipmanoeuvrability".

14.1.4 The main characteristics of the vessel affecting controllability, the characteristics of the steering gear and the steering nozzle are selected at the discretion of the designer and the shipowner, taking into account the need to ensure proper controllability of the vessel, corresponding to its purpose and operating conditions, the need to ensure compliance of the relative rudder areas or steering nozzles of the designed vessel and prototype vessel, provided, however, that the total efficiency of the selected rudders and (or) steering nozzles

shall not be less than assigned in the applicable requirements of **2.10**, Part **III** of these Rules and Directive (EU) 2016/1629 (Chapter 5 of ES-TRIN) with amendments

15. EMERGENCY OUTFIT

15.1 GENERAL

15.1.1 The items listed in Tables 12.2.1, 12.2.2-1, 12.2.2-2 i 12.2.3, may be included into the emergency outfit, provided these items have corresponding markings and their permanent storage places are situated above the bulkhead deck.

15.2 EMERGENCY OUTFIT REQUIRED

15.2.1 All ships except those specified in **15.2.4** and **15.2.6**, shall have emergency outfit in the scope not less than listed in Table 15.2.1.

For the unmanned non-self-propelled ships no emergency outfit is required. The manned non-selfpropelled ships shall be supplied with the emergency outfit in accordance with **15.2.10** like floating docks with no permanent direct communication with the shore.

Table 15.2.1

Nos.	Item, unit	Розмір	Quantity for ships of length <i>L</i> , in m				Quantity for tankers *
			150 and over	from 150 to 70 incl.	from 70 to 24 incl.	below 24	
1	2	3	4	5	6	7	8
1	Armoured collision mat, pc	4,5x4,5 m	1	–	–	–	–
2	Lightened collision mat, pc	3,0x3,0 m	–	1	–	–	1
3	Thrummed collision mat, pc	2,0x2,0 m	–	–	1	–	–
4	Thrummed pad, pc	0,4x0,5 m	4	3	2	1	2
5	Set of rigging tools.	as per Table 12.2.3	1	1	1	1	1
6	Set of fitter's tools	as per Table 12.2.3	1	1	1	1	1
7	Pine bar, pc	150x150x4000 mm	8	6	–	–	–
8	Pine bar, pc	80x100x 2000mm	2	2	4	–	4
9	Pine plank, pc	50x200x 4000mm	8	6	2	–	–
10	Pine plank, pc	50x200x2000mm	4	2	2	–	2
11	Pine wedge, pc	30x200x 200mm	10	6	4	–	4
12	Birch wedge, pc	60x200x 400mm	8	6	4	–	4
13	Pine plugs, pc	10x30x150mm	10	6	4	2	4
14	Pine plugs for ships with side scuttles, pc	side scuttle diameter	6	4	2	2	4
15	Unbleached canvas, m ²	–	10	6	4	2	–
16	Coarse felt, m ²	<i>s</i> = 10mm	3	2	1	–	–
17	Rubber plate, ²	<i>s</i> = 5mm	2	1	0,5	–	0,5
18	Tarred tow, kg	–	50	30	20	10	5
19	Wire (low-carbon steel pc 50 m each), pc	∅ 3mm	2	2	1	–	1
20	Construction shackles, pc	<i>d</i> = 12mm	12	8	4	–	4
21	Hexagon-head bolt, pc	M16x400mm	10	6	2	–	–
23	Hexagonal nut, pc	M16	16	10	6	4	–

24	Washer for bolt, pc	M16	32	20	12	8	–
25	Construction nails, kg	$l = 70\text{mm}$	4	3	2	1	1
26	Construction nails, kg	$l = 150\text{mm}$	6	4	2	1	1
27	Cement (quick setting), kg	–	400	300	100	100	100

End of Table 15.2.1

Nos	Item, unit	Pozmip	Quantity for ships of length L , in m				Quantity for tankers *
			150 and over	from 150 to 70 incl.	from 70 to 24 incl.	below 24	
1	2	3	4	5	6	7	8
28	Sand, natural, kg	–	400	300	100	100	100
29	Accelerator for concrete setting, kg	–	20	15	5	5	5
30	Minium, kg	–	15	10	5	5	5
31	Technical fat, kg	–	15	10	5	–	5
32	Carpenter's axe, pc.	–	2	2	1	1	1
33	Saw, cross-cut, pc	$l = 1200\text{mm}$	1	1	1	–	–
34	Hack-saw, pc	$l = 600\text{mm}$	1	1	1	1	1
35	Shovel, pc	–	3	2	1	1	1
36	Bucket, pc	–	3	2	1	1	1
37	Sledge hammer, pc	5kg	1	1	1	–	–
38	Lantern of explosionproof type, pc	–	1	1	1	1	1
39	Stop of telescopic type, pc	–	3	2	1	1	1
40	Emergency screw clamp, pc	–	2	1	1	–	–

Note. *Whatever the ship length, ice class and navigation area are.

15.2.2 Additional set of emergency outfit, above that listed in Table 15.2.1, shall be provided:
in accordance with Table 15.2.2-1 for passenger and special purpose ships, of 70 m in length and over, except for fiber-reinforced plastic ships;
in accordance with Table 15.2.2-2 for fiber-reinforced plastic ships.

Table 15.2.2-1

Nos	Item	Quantity
1	Portable autogenous cutting torch complete with set of fully charged gas cylinders	1
2	Hand jack, hydraulic	1
3	Blacksmith's sledge hammer	1
4	Forge chisel with haft	1
5	Crowbar	2
6	Jack 9,8 kN	1
7	Jack 19,6 kN	1

Table 15.2.2-2

Nos	Item	Quantity
1	Glass fabric	25m ²
2	Glass fabric	3kg
3	Resin binder with hardener	5kg

15.2.3 The sets of rigging and fitter's tools specified in Table 15.2.1, shall be completed according to Table 15.2.3.

Таблиця 15.2.3

Nos	Item	Size	Quantity per set	
			rigging	fitter's
1	Tape measure	$l = 2000$ mm	1	–
2	Bench hammer	0,5 kg	1	1
3	Sledge hammer	3,0 kg	–	1
4	Rigger's mallet	–	1	–
5	Puncher (dumb iron)	–	1	–
6	Chisel	$b = 20$ mm	1	1
		$l = 200$ mm		
7	Marline spike	$l = 300$ mm	1	–
8	Carpenter's chisel	$b = 20$ mm	1	–
9	Screw auger	$\varnothing 18$ mm	1	–
10	Tongs	$l = 200$ mm	1	–
11	Hollow punch	$\varnothing 18$ mm	–	1
12	Hollow punch	$\varnothing 25$ mm	–	1
13	Triangular file	$l = 300$ mm	–	1
14	Half-round file	$l = 300$ mm	–	1
15	Multi-purpose tongs	$l = 200$ mm	–	1
16	Screw driver	$b = 10$ mm	–	1
17	Adjustable wrench	Jaw width up to 36 mm	–	1
18	Wrench	Jaw width up to 24 mm	–	1
19	Rigger's knife	–	1	–
20	Hack-saw frame	–	–	1
21	Hack-saw blade	–	–	6
22	Kit-bag	–	1	1

15.2.4 For ships of restricted areas of navigation **R1, A-R1, A-R2, A-R2-RS, A-R2-S, R2, R2-S, R2-RS, R3-S, R3-RS, B-R3-S, B-R3-RS, C-R3-S**, except those specified in 15.2.5, equipment with emergency outfit and materials may be laid down as for the nearest lower group of ship's division depending on their length according to Table 15.2.1.

The minimum amount of emergency outfit for ships of restricted areas of navigation **R3, R3-IN** and **D-R3-S, D-R3-RS** shall be determined by the shipowner.

15.2.5 For **Ice5** and **Ice6** ice class ships, Polar class **PC1 ÷ PC6** and Baltic ice class **IA Super** equipment with emergency outfit and materials shall be established as for the nearest higher group of ship's division according to their length as per 15.2.1.

15.2.6 For glass-reinforced plastic ships provision of emergency outfit listed under items 6, 9, 17, 21–24, 26–29, 31, 35, 36, 39 i 40 of Table 15.2.1 is not required.

15.2.7 In ships intended to carry flammable and explosive cargoes tools of emergency outfit shall be made of nonsparking materials wherever practicable.

15.2.8 The tugs of restricted area of navigation **R3** and **R3-IN** need not be equipped with emergency outfit, except for the sets of rigging and fitter's tools required in accordance with Table 15.2.3.

15.2.9 For tugs of unrestricted service and restricted area of navigation **R1** with ice class **Ice5**, category equipment with emergency outfit and materials shall be established as for the nearest higher group according to Table 15.2.1.

15.2.10 The floating docks which are not in permanent direct communication with the shore shall have emergency outfit as indicated under items 5, 6, 19 - 26, 32 - 34 and 37 of Table 15.2.1, length of the floating dock L being taken in this case instead of the ship's length L .

The floating docks which are in permanent direct communication with the shore need not be provided with emergency outfit.

15.2.11 For berth-connected ships, the emergency outfit shall be chosen by the owner.

15.2.12 Ships having a distinguishing mark **FF1**, **FF1WS**, **FF2**, **FF2WS** and **FF3WS** in the class notation shall have two searchlights capable of providing an efficient horizontal and vertical range of illumination of a surface not less than 10 m in diameter at a distance up to 250 m at the minimum illumination intensity up to 50 lx at dark time and clear atmosphere.

15.3 STORAGE OF EMERGENCY OUTFIT

15.3.1 The emergency outfit indicated in 15.2 shall be stored at least in two emergency stations, one of which shall be situated in the machinery space.

Emergency stations may be special spaces, boxes or places allocated on the deck or in spaces.

In the emergency station of the machinery space the outfit necessary for carrying out the emergency operations inside the space shall be stored; the rest of the emergency outfit shall generally be stored in the emergency stations located above the bulkhead deck;

in ships of less than 45 m in length it is allowed to locate the emergency station below the bulkhead deck on condition that free access to this station is provided at all times.

In ships of 31 m in length and below it is allowed to store the emergency outfit only in one emergency station.

15.3.2 A free passage shall be provided in front of the emergency station; the passage width shall be selected depending on the overall dimensions of the outfit stored in the station but not less than 1,2 m. In ships of less than 70 m in length the passage width is allowed to be reduced to 0,8 m and in ships of 31 m in length and below to 0,6 m.

The passages to the emergency stations shall be as straight and short as practicable.

15.4 MARKING

15.4.1 Items of the emergency outfit and cases for their storage (apart from collision mats) shall be painted blue either entirely or in a stripe.

The cases for emergency equipment storage shall have the distinct inscription to indicate the name of the material, weight and warranted storage period.

15.4.2 The emergency stations shall be provided with distinct inscriptions "Emergency Station". Moreover, in the passages and on the decks notices shall be posted showing location of the emergency stations.

15.5 COLLISION MATS

15.5.1 Collision mats shall be made of water-resistant canvas or other equivalent fabric and be provided with either a soft or wire interlayer depending on the type of the collision mat. The collision mats shall be edged by a leech rope with four thimbles fitted into its corners. Moreover, cringles shall be provided according to the number of ropes specified in Table 15.5.1.

Basic data on the collision mats are given in Table 15.5.1 and Fig. 15.5.1.

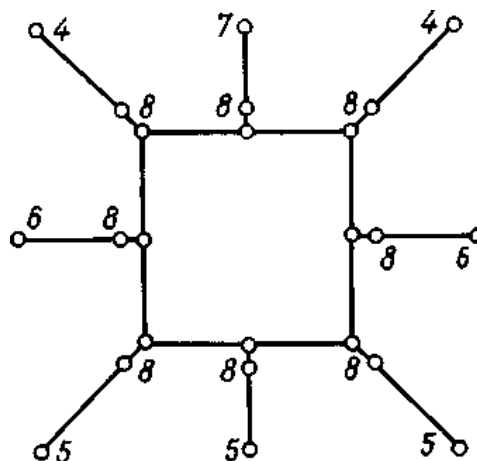

Fig.15.5.1

Table 15.5.1

Nos	Item	Quantity		
		Armoured collision mat, 4,564,5 m	Lightened collision mat, 3,063,0 m	Thrummed collision mat, 2,062,0 m
1	Canvas layers	4	2	2
2	Interlayer	wire net with leech rope	felt padding	1 pad
3	Fastening of stiffeners	–	In pockets (pieces of wire rope or pipes)	–
4	Sheets	2	2	2
5	Hogging lines	3	2	2
6	Guys	2	2	–
7	Control lanyard with marking	1	1	1
8	Shackles	12	9	6
9	Tackles (safe working load)	4 (14,7 kN)	2 (9,8 kN)	2 (9,8 kN)
10	Snatch blocks (safe working load)	4 (14,7 kN)	2 (9,8 kN)	2 (9,8 kN)

15.5.2 The pads shall be made of natural fibre rope strands and be thrummed with natural fibre spun yarn. A canvas shall be sewn on the bottom side of the pad.

15.5.3 Sheets and guys of armoured collision mats shall be made of flexible steel wire ropes, control lanyards - of natural fibre ropes and hogging lines for all collision mats - of flexible steel wire ropes or chains having suitable diameter.

Wires of steel ropes shall have heavy zinc coating in accordance with the national standards.

The length of the sheets shall be chosen so that a hole may be shut up in any place of the shell plating and the ends of the ropes may be efficiently secured on the deck.

Breaking strength of the whole sheets shall exceed that of the leech ropes by not less than 25 %.

15.5.4 The blocks of emergency outfit may have hooks as hangers. The permissible load of the shackles joining the ropes shall not be less than 0,25 times the breaking load of the whole ropes referred to above.

APPENDIX 1

CALCULATION OF THE WIDTH OF STAIRWAYS SORMING MEANS OF ESCAPE ON PASSENGER SHIPS AND ON SPECIAL PURPOSE SHIPS CARRYING MORE THAN 60 PERSONS

1. The calculation method considers evacuation from enclosed spaces within each main vertical zone individually and takes into account all of the persons using the stairway enclosures in each zone, even if they **enter that stairway from another main vertical zone.**

2. For each main vertical zone the calculation shall be completed for the night time (case 1) and day time (case 2) and the largest dimension from either case used for determining the stairway width for each deck under consideration.

3. For multi-deck ships, the total stairway width W , in mm, which allows for the timely flow of persons evacuating from adjacent decks is determined using the following calculation method:

when joining two decks:

$$W = (N_1 + N_2) \cdot 10; \quad (3-1)$$

when joining three decks

$$W = (N_1 + N_2 + 0,5N_3) \cdot 10; \quad (3-2)$$

when joining four decks

$$W = (N_1 + N_2 + 0,5N_3 + 0,25N_4) \cdot 10, \quad (3-3)$$

where: N_1 – the number of persons to be evacuated from deck with the largest number of persons using the stairway;

N_2 – the number of persons to be evacuated from the deck with the next largest number of persons directly entering the stairway etc., i.e. $N_1 > N_2 > N_3 > N_4$.

When joining five or more decks, the total stairway width shall be determined by Formula (3-3) with regard for the number of tiers and their capacity (refer to Fig. 3-1).

The calculated value of W may be reduced where available landing area is provided in stairways at the deck level (refer to Fig. 3-2).

The doors to the muster station shall have an aggregate width of at least

$$D = 900 + 9355 = 10255$$

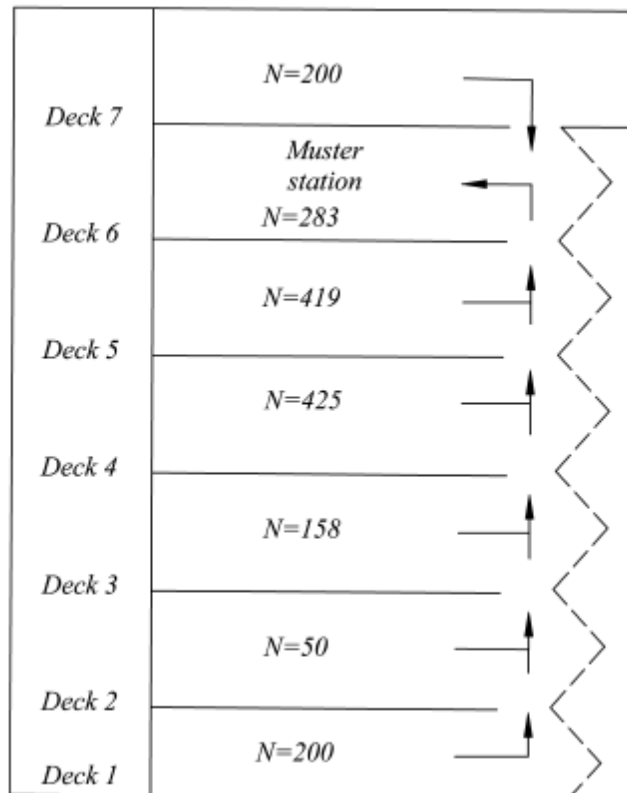

Fig.3-1 Minimum stairway width calculation example:

Deck 1:

$$N_1 = 200, W = 200 \cdot 10 = 2000 ;$$

Deck 2:

$$N_1 = 200, N_2 = 50,$$

$$W = (200 + 50) \cdot 10 = 2500 ;$$

Deck 3:

$$N_1 = 200, N_2 = 158, N_3 = 50,$$

$$W = (200 + 158 + 0,5 \cdot 50) \cdot 10 = 3830 ;$$

Deck 4:

$$N_1 = 425, N_2 = 200,$$

$$N_3 = 158, N_4 = 50,$$

$$W = (425 + 200 + 0,5 \cdot 158 + 0,25 \cdot 50) \cdot 10 = 7165 ;$$

Deck 5:

$$N_1 = 425, N_2 = 419, N_3 = 158, N_4 = 50,$$

$$W = (425 + 419 + 0,5 \cdot 158 + 0,25 \cdot 50) \cdot 10 = 9355 ;$$

Deck 7:

$$N_1 = 200, W = 900 .$$

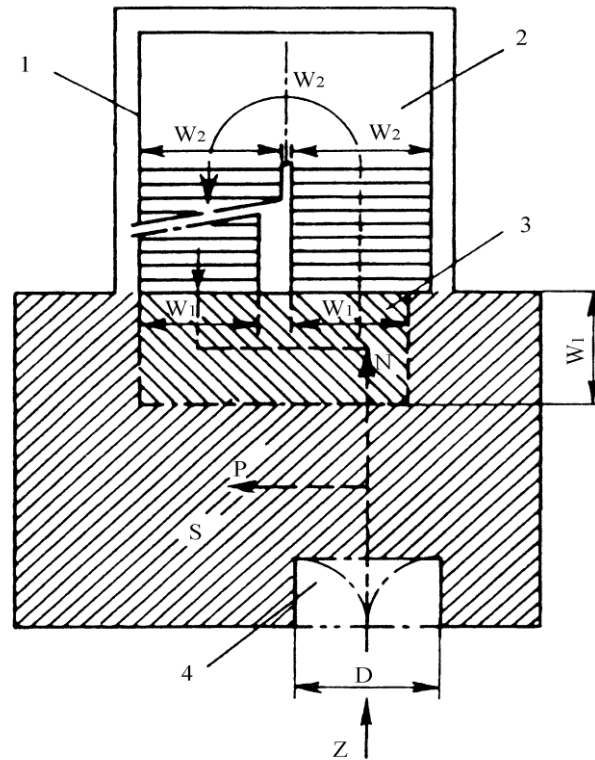

Fig.3-2 Landing calculation for stairway width reduction:

- 1 – handrail on both sides of the stairway;
- 2 – intermediate landing;
- 3 – necessary flow area for accessing the flow on the stairs;
- 4 – door area;

$P = S \times 3 \text{ persons/m}^2$ – the number of persons taking refuge on the landing to a maximum value of $P_{\max} = 0,25Z$;

$N = Z - P$ – the number of persons directly entering the stairway flow from a given deck;

Z – the number of persons to be evacuated from the deck considered;

S – available landing area, in m^2 , after subtracting the surface area necessary for movement and subtracting the space taken by the door swing area;

D – width of exit doors to the stairway landing area, in mm.

4. The stairway shall not decrease in width in the direction of evacuation to the muster station, except in the case of several muster stations in one main vertical zone the stairway width shall not decrease in the direction of the evacuation to the most distant muster station.

5. Where the passengers and crew are held at a muster station which is not at the survival craft embarkation position the dimensions of stairway width and doors from the muster station to this position shall be based on the number of persons in the controlled groups. The width of these stairways and doors need not exceed 1500 mm unless larger dimensions are required for evacuation from these spaces under normal conditions.

6. The calculations of stairway width shall be based upon the crew and passenger load on each deck. For the purpose of the calculation the maximum capacity of a public space shall be defined by either of the following two values: the number of seats or similar arrangements, or the number obtained by assigning 2 m^2 of gross deck surface area to each person.

7. The dimensions of the means of escape shall be calculated on the basis of the total number of persons expected to escape by the stairway and through doorways, corridors and landing (refer to Fig. 7).

Calculations shall be made separately for the two cases of occupancy of the spaces specified below. For each component part of the escape route, the dimension taken shall not be less than the largest dimension determined for each case.

Case 1:

passengers in cabins with maximum berthing capacity fully occupied;

members of the crew in cabins occupied to 2/3 of maximum berthing capacity;
 service spaces occupied by 1/3 of the crew.

Case 2:

passengers in public spaces occupied to 3/4 of maximum capacity;
 members of the crew in public spaces occupied to 1/3 of maximum capacity;
 service spaces occupied by 1/3 of the crew;
 crew accommodation occupied by 1/3 of the crew.

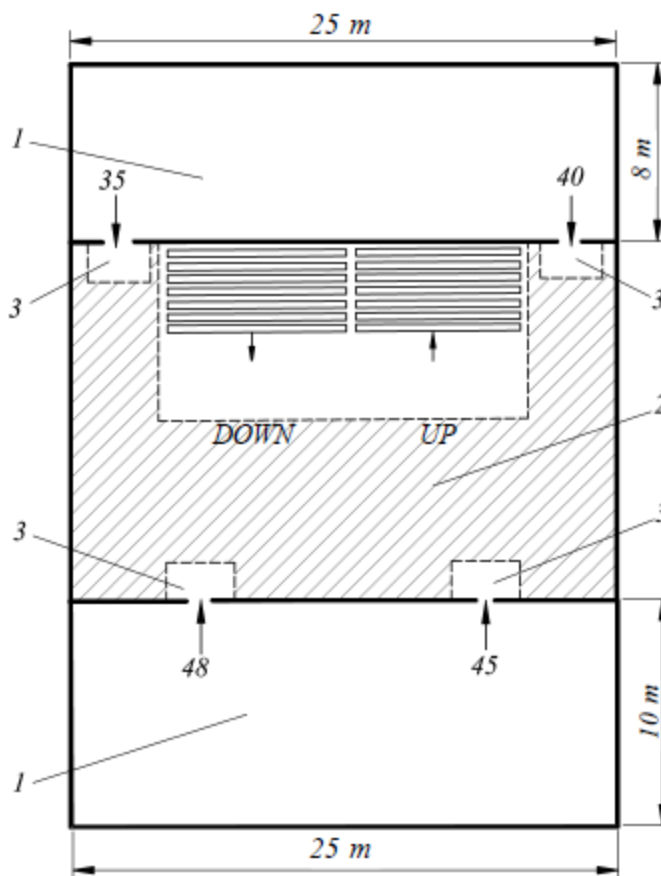

Fig.7 Occupant loading calculation example:

- 1 – public space;
- 2 – landing credit area;
- 3 – door area;

DOWN, UP – stairway flow path for upper space:

$$Z_{(pers.)} = \frac{25 \text{ m} \cdot 8 \text{ m}}{2 \text{ m}^2} = 100; N_{(pers.)} = 100 \cdot 0,75 = 75;$$

for lower space:

$$Z_{(pers.)} = \frac{25 \text{ m} \cdot 10 \text{ m}}{2 \text{ m}^2} = 125; N_{(pers.)} = 125 \cdot 0,75 = 93$$

8. The maximum number of persons contained in a vertical zone including persons entering stairways from another main vertical zone shall not be assumed to be higher than the maximum number of persons authorized to be carried on board for the calculation of the stairway width only.

ADDITIONAL REQUIREMENTS

1. The aggregate width of stairway exit doors to the muster station shall not be less than the aggregate

width of stairways serving this deck.

2. Means of escape plans shall be provided indicating the following:

.1 the number of crew and passengers in all normally occupied spaces;

.2 the number of crew and passengers expected to escape by the stairway and through doorways, corridors and landing;

.3 muster stations and survival craft embarkation positions;

.4 primary and secondary means of escape;

.5 width of stairways, doors, corridors and landing areas.

3. Means of escape plans shall be accompanied by detailed calculations for determining the width of escape stairways, doors, corridors and landing areas.

APPENDIX 2

SAFE ENTERING INTO CARGO HOLDS, CARGO AND BALLAST TANKS AND OTHER SPACES

1. Safe access¹ to cargo holds, cargo and ballast tanks and other premises of the cargo area shall be directly from the open deck and shall be such as to ensure full inspection of these premises.

Safe access to the double bottom or forepeak is possible through the pump room, deep cofferdam, pipeline tunnel, cargo hold, double hull or similar compartment, which is not intended for the carriage of oil or hazardous goods.

2. Tanks and tank compartments of 35 m in length or more shall be equipped with at least two access hatches and access ladders, located as far as possible from each other.

Tanks less than 35m in length shall be equipped with at least one hatch and ladder for access.

If a tank is divided by one or more baffle bulkheads or similar obstacles that do not provide easy access to other parts of the tank, it shall be fitted with at least two access hatches and ladders.

3. Each cargo hold shall be equipped with at least two access means, as far as practicable, as far apart as possible.

As a rule, these means for access are located diagonally, for example, one in the nasal forward bulkhead from the port side, and the second in the aft bulkhead from the starboard side.

¹ Refer to IMO A.1050(27) – «Revised Recommendations for Entering Enclosed Spaces aboard Ships».



Veritas Register of Shipping LTD

Rules for Classification and Construction of Sea Going Ships
Part III
Equipment, arrangements and outfit

Veritas Register of Shipping LTD
Office №19, Tower "A", Chavchavadze Str. №5,
Batumi 6000, Georgia
Tel.: +995 422 227427
E-mail: headoffice@vrsclass.com