

VERITAS REGISTER OF SHIPPING

**RULES FOR THE CLASSIFICATION AND
CONSTRUCTION OF SEAGOING SHIPS**

**Part II
Hull**



BATUMI 2024

Veriras Register of Shipping Ltd

Rules for classification and construction of seagoing ships

Part II "Hull"

These Rules developed on the basis of the Rules for classifications and constructions of seagoing ships on Ukrainian Register of Shipping with taking into account the experience of their application, changes in the applicable International conventions, Codes and Resolutions adopted by the International Maritime Organization (IMO) with applicable amendments and changes in the applied resolutions of the United Nations Economic Commission for Europe and directives of the European Parliament and Council.

Rules for classification and construction of sea-going ships consist of following parts:

Part I Classification;

Part II "Hull";

Part III "Equipment, Arrangements and Outfit";

Part IV "Stability";

Part V "Subdivision";

Part VI "Fire Protection";

Part VII "Machinery Installations";

Part VIII "Systems and Piping";

Part IX "Machinery";

Part X "Boilers, Heat Exchangers and Pressure Vessels";

Part XI "Electrical Equipment";

Part XII "Refrigerating Plants";

Part XIII "Materials";

Part XIV "Welding";

Part XV "Automation";

Part XVI "Structure and Strength of Fiber-Reinforced Plastic Ships";

Documents have been approved in accordance with the established approval procedure and come into force on 1st July of 2024.

The Rules are published in English. Official version of Rules for classifications and constructions of seagoing ships located on the official web site of Veritas Register of Shipping on the link <https://vrsclass.com/>

Official edition of the Veritas Register of Shipping

© **Ukrainian Register of Shipping**

PART II HULL

1. DESIGN PRINCIPLES

1.1 GENERAL

1.1.1 Application.

1.1.1.1 Unless provided otherwise, requirements of the present Part of the Rules apply to steel ships of welded construction, from 12 to 350 m in length whose proportions are taken within the limits given in Table 1.1.1.1.

Table 1.1.1.1

Proportions of main dimensions	Navigation area					
	Unrestricted, A	R1, A-R1	R2, A-R2	R2-S, R2-RS, A-R2-S, A-R2-RS	R3-S, R3-RS, B-R3-S, B-R3-RS	R3, R3-IN, C-R3-S, C-R3-RS, D-R3-S, D-R3-RS
The length of the ship to the depth L/D	18	19	20	21	22	23
The breadth of the ship to the depth B/D	2,5	2,5 ¹	3 ²	3	3	4 ³
¹ For vessels of dredging fleet, not more than 3. ² For vessels of industrial fleet, not more than 4. ³ For floating cranes, not less than 4,5.						

The requirements of the present Part of the Rules do not apply to oil tankers of 150 m in length and above and to bulk carriers of 150 m in length and above, of unrestricted navigation area, which design includes one deck, topside tanks and side hopper tanks in cargo areas excluding ore carriers and combined ships:

- contracted for construction on or after 1 July 2016;
- in the absence of a contract for construction, which keels were laid or which were at a similar stage of construction on July 1, 2017 or after that date; or
- which were commissioned on July 1, 2020¹ or after that date.

The scantlings of hull members, essential to the strength of hull and the construction of the said ships are regulated by IACS Common Rules for Bulk Carriers and Oil Tankers. The requirements of this part may be used if it is stipulated in these parts.

1.1.1.2 The scantlings of hull members, essential to the strength of ships whose construction and main dimensions are not regulated by the present Rules are subject to special consideration by the Register.

1.1.1.3 Draft fore of mixed (sea – river) navigation ships, in all load conditions, shall not be less than:

- .1** for ships with sign **R2-RS(6,0)** – 2,9 m with $L \geq 60,0$ m and not less than 1,6 m with $L \leq 25,0$ m;
- .2** for ships with sign **R2-RS(4,5)** – 2,2 m with $L \geq 60,0$ m and not less than 1,2 m with $L \leq 25,0$ m;
- .3** for ships with sign **R3-RS** – 1,7 m with $L \geq 60,0$ m and not less than 0,9 m with $L \leq 25,0$ m;

For the intermediate values of L and intermediate wave height values, among specified in **.1** and **.2**, the minimum allowable draft fore is determined by linear interpolation.

¹ Refer to IMO Resolution MSC.290(87)

1.1.1.4 Ships of mixed (sea – river) navigation, having in class notation signs **R2-RS** or **R3-RS**, namely: self-propelled cargo ships, tugs, towed barges, and pushed barges, shall be fitted with double sides and double bottom.

Double sides shall be provided within cargo holds (cargo tanks). Double bottom shall be arranged from collision (forepeak) bulkhead to after peak bulkhead. On towing vessels double sides may not be provided and double bottom shall be arranged from forepeak to after peak bulkhead, as far as practicable and compatible with the design and normal operation of the vessel.

In this case, any part of the towing vessel not fitted with a double bottom shall be capable of withstanding the damage to the bottom referred to in 2, Part V "Subdivision".».

1.1.2 General.

1.1.2.1 All hull structures regulated by this Part are subject to the Register survey. For this purpose an access shall be provided for their survey.

1.1.2.2. The structures regulated by this Part shall comply with the requirements of Part XIII "Materials" and Part XIV "Welding" and with the approved technical documentation listed in **4.2.3** Part I "Classification" of the Rules for the Classification and construction of Sea-going Ships².

1.1.2.3 Tightness test of ship's hull shall be carried out according to the provisions of Appendix 1.

1.1.3 Definitions and explanations.

The definitions and explanations relating to the general terminology of the Rules are given in Part I "Classification".

For the purpose of the present Part of the Rules the following definitions and explanations have been adopted.

Moulded depth D is the vertical distance measured amidships from the top of the plate keel or from the point where the inner surface of shell plating abuts upon the bar keel, to the top of the upper deck beam at side. In ships having a rounded gunwale, the depth is measured to the point of intersection of the moulded lines of upper deck and side, the lines extending so as if the gunwale were of angular design.

Length L is the distance, in m, on the summer load waterline from the forward side of the stem to the after side of the rudder post or to the centre of the rudder stock if there is no rudder post, or the distance equal to 96 per cent of the length on the summer load waterline from the forward side of the stem to the after side of after end of the ship, whichever is the greater.

However, *L* need not be greater than 97 per cent of the ship's length on the summer load waterline.

Ship's ends are portions of the ship's length beyond the midship region.

Block coefficient C_b is the block coefficient at draught *d* corresponding to summer load waterline, based on length *L* and breadth *B*, determined by the formula

$$C_b = \frac{\text{Moulded displacement (m}^3\text{)}}{LBd}$$

After perpendicular is a vertical line run through the ship centreline, which limits the ship length *L* at the aft end.

Summer load waterline is the waterline on the level of the centre of the load line ring for the ship's position without heel and trim.

Engine room aft corresponds to the position of the mid-length of the engine room beyond 0,3*L* aft of amidships.

Midship section is the hull section at the middle of ship's length *L*.

Superstructure is a decked structure on the upper deck extending from side to side of the ship or with the side plating not being inboard of the shell plating more than 4 % of the breadth of the ship.

Tight structure is a structure impervious to water and other liquids.

Forward perpendicular is a vertical line run through the ship centreline at a point where the summer loadline and the fore side of stem intersect.

Draught d is the vertical distance measured amidships from the top of the plate keel, or the point where the inner surface of the shell plating abuts upon the bar keel, to the summer load waterline. In ships with timber freeboard the draught shall be measured at side to the summer timber load waterline.

Upper deck is the uppermost continuous deck extending the full length of the ship.

²Hereinafter – Part I «Classification».

Superstructure deck is a deck forming the top of a tier of superstructure.

Where the superstructure has several tiers, the superstructure decks are called as follows: first tier superstructure deck, second tier superstructure deck, etc., counting from the upper deck.

Freeboard deck is the deck from which the freeboard is calculated.

Lower decks are the decks located below the upper deck.

Where the ship has several lower decks, they are called: second deck, third deck, etc., counting from the upper deck.

Freeboard deck is the deck from which the freeboard is calculated.

Strength deck is the deck forming the upper flange of hull girder. The uppermost continuous deck, long bridge deck, long forecastle or long poop deck outside end regions, or quarter deck outside the transition area may be considered as the strength deck (refer to **2.12.1.2**).

Deckhouse top is a deck forming the top of a tier of a deckhouse.

Where the deckhouse has several tiers, the deckhouse tops are called as follows: first tier deckhouse top, second tier deckhouse top, etc., counting from the upper deck. If a deckhouse is fitted on a superstructure deck of first tier, second tier, etc., the deckhouse top is called accordingly the top of second tier deckhouse, third tier deckhouse, etc.

Platform is a lower deck extending over portions of the ship's length or breadth.

Deckhouse is a decked structure on the upper deck or superstructure deck with its side plating, on one side at least, being inboard of the shell plating by more than 4 % of the breadth of the ship.

Midship region is the part of the ship's length equal to $0,4L$ ($0,2L$ forward and aft of amidships), unless expressly provided otherwise.

Specified speed of ship v_0 is the maximum speed of the ship, in knots, at the summer load waterline in still water at rated engine speed of propulsion plant.

$g = 9,81 \text{ m/s}^2$ - acceleration due to gravity;

$\rho = 1,025 \text{ t/m}^3$ - density of sea water.

Moulded breadth B is the greatest moulded breadth, in m, measured amidships from outside of frame to outside of frame.

Main frames are vertical side framing members fitted in the plane of floors or bilge brackets within a spacing of each other.

Intermediate frames are additional frames fitted between main frames.

Spacing is the distance between primary members, determined on the basis of the value of standard spacing a_0 , in m, determined by the formula

$$a_0 = 0,002L + 0,48.$$

Deviation from normal spacing may be permitted. In this case, it is recommended to assume the spacing of more than $0,6a_0$ and less than $1,25a_0$.

In the fore and after peaks it is not recommended to assume the spacing of more than 0,6 m, between the fore peak bulkhead and $0,2L$ aft of the forward perpendicular - of more than 0,7 m.

1.1.4 Basic provisions for determining the scantlings of hull members.

1.1.4.1 The scantlings of hull members are regulated based on the design loads, calculation methods and safety factors specified in this Part with due regard to corrosion allowance (refer to **1.1.5**).

1.1.4.2 Derivation of the scantlings of hull members in these Rules is based on structural idealization using beam models subject to bending, shear, longitudinal loading and torsion having regard to the effect of adjacent structures.

1.1.4.3 For the purpose of these Rules, the design characteristics of the material used for hull structures shall be as follows:

R_{eH} – upper yield stress, in MPa;

σ_n – design specified yield stress for normal stresses, in MPa, determined by the formula

$$\sigma_n = 235/\eta, \quad (1.1.4.3-1)$$

where: η – application factor of mechanical properties of steel, determined from Table 1.1.4.3;

τ_n – design specified yield stress for shear stresses, in MPa, determined by the formula

$$\tau_n = 0,57\sigma_n. \quad (1.1.4.3-2)$$

Table 1.1.4.3

R_{eH}	235	315	355	≥ 390
η	1,0	0,78	0,72	0,68
σ_n	235	301	326	346

1.1.4.4 The requirements for strength of structural members and structures as a whole aiming at determining their scantlings and strength characteristics are set forth in these Rules by assigning the specified values of permissible stresses for design normal $\sigma_p = k_\sigma \sigma_n$ and shear $\tau_p = k_\tau \tau_n$ stresses (where k_σ and k_τ – factors of permissible normal and shear stresses respectively).

The values of where k_σ and k_τ are given in the relevant chapters of this Part.

1.1.4.5 The buckling strength requirements are imposed upon the structural members subject to considerable compressive normal and/or shear stresses (refer to **1.6.5**).

1.1.4.6 The thickness of hull structural members determined according to the requirements of this Part shall be the minimum thickness specified for particular structures in the relevant chapters of this Part.

Minimum thickness are given for structural elements of usual carbon steel. When using high-strength steel minimum thickness may be reduced in proportion to the value of $\sqrt{\eta}$. This decrease is not subject to the minimum thickness of the vertical keel, bottom stringers and floors of Group I ships and the minimum thickness of the structures inside the cargo and ballast tanks of Group II ships (the division of ships into groups according to the terms of corrosion wear - refer to **1.1.5.2**), as well as plating and members of tanks framing.

For ships of restricted areas of navigation **R2, R2-S, R2-RS, A-R2, A-R2-S, A-R2-RS, B-R3-S, B-R3-RS, C-R3-S, C-R3-RS, R3-S, R3-RS, R3, R3-IN, D-R3-S, D-R3-RS** a reduction in the thickness of hull members is permitted, but not in excess of the values given in Table 1.1.4.6.

Table 1.1.4.6 Permissible reduction of minimum hull member thickness

Hull members	Район плавания	
	R2, R2-S, R2-RS, A-R2, A-R2-S, A-R2-RS, B-R3-S, B-R3-RS, C-R3-S, C-R3-RS	R3-S, R3-RS, R3, R3-IN, D-R3-S, D-R3-RS
Primary support members in way of ballast tanks	15%	30%
Other hull members	10%	20%

In all cases, unless expressly provided otherwise, the hull member thickness shall not be less than 4 mm.

1.1.4.7 In this Part, the requirements for determining the hull member scantlings are based on the assumption that during the construction and service of a ship measures are taken for the corrosion prevention of the hull in accordance with current standards and other current normative documents.

1.1.4.8 On agreement with the shipowner, a reduction in the scantlings of certain hull members may be permitted.

The reduced scantlings as well as scantlings determined in accordance with the requirements of these Rules for the 25-years service life of the ship shall be expressly indicated in the hull structural drawings submitted to the Register for review. A special entry shall be made in the Classification Certificate of such ships (refer to **2.3.1**, Part I "Classification").

1.1.5 Corrosion allowance.

1.1.5.1 Corrosion allowance Δs , in mm, is set for the structures whose planned service life exceeds 12 years and is determined by the formula:

$$\Delta s = u(T - 12), \quad (1.1.5.1)$$

where u average annual reduction in thickness of the member, in mm per annum, due to corrosion wear or tear according to 1.1.5.2;

T – planned service life of structure, in years;

if service life is not specially prescribed, T shall be taken equal to $T = 25$.

For the structures whose planned service life is less than 12 years, $\Delta s = 0$.

In the drawings of hull structures, which planned service life has been taken to be less than 25 years, scantlings determined at $T = 25$ shall be additionally indicated.

A special entry shall be made in the Classification Certificate of such ships (refer to **2.3.1**, Part I "Classification").

1.1.5.2 When there are no special requirements for service conditions and means of corrosion prevention

of the hull for determining the scantlings of hull members according to the Rules one shall be guided by the data on the average annual reduction in thickness u , of structural member given in Table 1.1.5.2-1 and 1.1.5.2-2, depending on the group of ships and the designation of the space.

Tables 1.1.5.2-1 and 1.1.5.2-2 provide for division of all ships into two groups depending on corrosion wear conditions:

I – dry cargo ships and similar ships as regards the service conditions;

II – tankers, bulk carriers, combination carriers and similar ships as regards the service conditions.

For the webs separating the different purpose compartments, u is determined as the average value for adjacent compartments.

In sound cases, in agreement with the shipowner thickness of some hull structural members may be reduced to values, agreed with the Register.

The average structural members thickness reduction of restricted navigation area ships operated in fresh water for 50 and more per cent of the service life is specified in the Table 1.1.5.2-2. If the ship is operated in fresh water at least 50% of operational service life, average structural hull members thickness reduction shall be determined by linear interpolation between Tables 1.1.5.2-1 and 1.1.5.2-2 depending on the percentage of ship in fresh water. For ships of restricted service, intended to operate only in fresh water basins, the value of u may be reduced 2,5 times for group I and 1,2 times for group II relative to the corresponding values specified in the Table 1.1.5.2-1.

In the drawings of hull structures, which scantlings have been adopted with regard to the reduced value of u , the reduced scantlings determined at u according to Tables 1.1.5.2-1 and 1.1.5.2-2. shall be additionally indicated.

A special entry shall be made in the Classification Certificate of such ships (refer to 2.3.1, Part I "Classification").

Table 1.1.5.2-1 Average annual reduction in thickness of structural members

Nos.	Structural member	u , in mm per annum	
		Group I	Group II
1	2	3	4
1	Plating of decks and platforms		
1.1	Upper deck	0,10	0,20 ^{1,2}
1.2	Lower deck	0,11	–
1.3	Deck in accommodation and working spaces	0,14	0,14
2	Side plating		
2.1	Side (no inner skin is provided):		
2.1.1	freeboard	0,10	0,13 ²
2.1.2	in the region of alternating waterlines	0,17	0,19 ²
2.1.3	below the region of alternating waterlines	0,14	0,16
2.2	Side (inner skin is provided) (compartments of double skin side are not designed to be filled):		
2.2.1	freeboard	0,10	0,10
2.2.2	in the region of alternating waterlines	0,17	0,17
2.2.3	below the region of alternating waterlines	0,14	0,14
2.3	Side (inner skin is provided) (compartments of double skin side are designed for the of carriage cargo, fuel oil or water ballast):		
2.3.1	freeboard:		
	.1 tanks filled with fuel oil	0,19	0,19
	.2 tank for reception of water ballast	0,21	0,21
2.3.2	in the region of alternating waterlines:		
	.1 tanks filled with fuel oil	0,18	0,18
	.2 tank for reception of water ballast	0,21	0,21
2.3.3	below the region of alternating waterlines:		
	.1 tanks filled with fuel oil	0,17	0,17
	.2 tank for reception of water ballast	0,18	0,18
3	Bottom plating		
3.1	Bottom (inner bottom is not provided):		
3.1.1	including bilge	0,14	–
3.1.2	in way of cargo tanks	–	0,17

Nos.	Structural member	u , in mm per annum	
		Group I	Group II
3.1.3	in way of fuel oil tanks	0,17	0,17
3.1.4	in way of ballast compartments	0,20	0,20
3.1.5	flat keel	0,23	0,25
3.2	Bottom (inner bottom is provided):		
3.2.1	including bilge	0,14	0,14
3.2.2	in way of cargo tanks	0,15	0,15
3.2.3	in way of ballast compartments	0,20	0,20
3.2.4	flat keel	0,20	0,20
4	Plating of inner bottom, hopper tank and trapezoidal stools under transverse bulkheads		
4.1	Inner bottom in the area of cargo holds (tanks):		
4.1.1	in way of fuel oil tanks	0,12	0,17
4.1.2	in way of ballast compartments	0,15	0,20
4.1.3	in way of boiler room	0,30	0,30
4.1.4	in way of engine room	0,20	0,20
4.1.5	with no wood sheathing in holds if cargo is expected to be discharged by grabs	0,30	0,30
4.2	Hopper tanks, trapezoidal stools under transverse bulkheads, margin plate:		
4.2.1	plating of hopper tanks and trapezoidal stools:		
	bottom strake	0,25	0,30
	other strakes	0,12	0,17
4.2.2	margin plate (inclined and horizontal)	0,20	0,22
4.2.3	margin plate in boiler room:		
	inclined	0,28	0,30
	horizontal	0,23	0,28
5	Plating of longitudinal and transverse bulkheads of inner skin		
5.1	Watertight bulkheads:		
5.1.1	top strake	0,10	–
5.1.2	middle strake	0,12	–
5.1.3	bottom strake	0,13	–
5.2	Bulkheads between holds loaded with bulk cargoes:		
5.2.1	top strake (0,1 D from the upper deck)	–	0,13
5.2.2	other strakes	–	0,18
5.3	Bulkheads between holds loaded with oil cargo or bulk cargo:		
5.3.1	top strake (0,1 D from the upper deck)	–	0,16
5.3.2	other strakes	–	0,18
5.4	Bulkheads between cargo tanks:		
5.4.1	top strake (0,1 D from the upper deck)	–	0,20 ²
5.4.2	middle strake	–	0,13 ²
5.4.3	bottom strake	–	0,18
5.5	Bulkheads between cargo and ballast compartments:		
5.5.1	top strake (0,1 D from the upper deck)	0,13	0,30
5.5.2	middle strake	0,15	0,25
5.5.3	bottom strake	0,16	0,20
5.6	Topside tanks	0,12	0,20
6	Framing of decks and platforms		
6.1	Deck longitudinals and beams of decks and platforms forming boundaries of:		
6.1.1	holds loaded with general cargoes	0,12	–
6.1.2	holds loaded with bulk cargoes	–	0,15
6.1.3	holds loaded with crude oil and petroleum products or bulk cargoes	–	0,18
6.1.4	cargo tanks	–	0,25 ²
6.1.5	fuel oil tanks	0,15	0,17
6.1.6	ballast compartments	0,18	0,20
6.2	Deck girders, transverses of decks and platforms forming boundaries of:		
6.2.1	holds loaded with general cargoes	0,12	–
6.2.2	holds loaded with bulk cargoes	–	0,13
6.2.3	holds loaded with crude oil and petroleum products or bulk cargoes	–	0,15

Nos.	Structural member	u , in mm per annum	
		Group I	Group II
6.2.4	cargo tanks	–	0,20 ²
6.2.5	fuel oil tanks	0,19	0,19
6.2.6	ballast compartments	0,21	0,21
6.3	Cargo hatch coamings	0,10	0,12
7	Framing of sides and bulkheads		
7.1	Longitudinals, main and web frames, cross ties, vertical stiffeners and horizontal girders of sides and bulkheads forming boundaries of:		
7.1.1	holds loaded with general cargoes	0,10	–
7.1.2	holds loaded with bulk cargoes	–	0,13
7.1.3	holds loaded with crude oil and petroleum products or bulk cargoes	–	0,15
7.1.4	cargo tanks	–	0,20 ^{2,3}
7.1.5	fuel oil tanks	0,18 ³	0,18 ³
7.1.6	ballast compartments	0,21	0,21
8	Framing of bottom and inner bottom		
8.1	Bottom centre girder, side girders, floors and bottom longitudinal girders (inner bottom is omitted):		
8.1.1	in general cargo compartments	0,14	–
8.1.2	in cargo tanks	–	0,20
8.1.3	in ballast compartments	0,20	0,20
8.1.4	under the boilers	0,30	0,30
8.2	Bottom centre girder, side girders, floors, bottom and inner bottom longitudinals in double bottom compartments:		
8.2.1	not intended to be filled	0,14	0,14
8.2.2	in oil fuel tanks	0,15	0,15
8.2.3	in water ballast tanks	0,20	0,20
8.2.4	under the boilers	0,25	0,25
9	Superstructures, deckhouses and bulwarks		
9.1	Shell plating	0,10	0,10
9.2	Framing	0,10	0,10

Table 1.1.5.2- Average annual reduction in thickness of structural members for ships intended for operation in fresh water for 50 and more percent of operational service life

Nos	Structural member	u , in mm per annum	
		Group I	Group II
1	2	3	4
1	Plating of decks and platforms		
1.1	Upper deck	0,08	0,13 ¹
1.2	Lower deck	0,08	–
1.3	Deck in accommodation and working spaces	0,08	0,08
2	Side plating		
2.1	Side (no inner skin is provided):		
2.1.1	freeboard	0,08	0,08
2.1.2	in the region of alternating waterlines	0,12	0,12
2.1.3	below the region of alternating waterlines	0,12	0,12
2.2	Side (inner skin is provided) (compartments of double skin side are not designed to be filled):		
2.2.1	freeboard	0,08	0,08
2.2.2	in the region of alternating waterlines	0,12	0,12
2.2.3	below the region of alternating waterlines	0,12	0,12
2.3	Side (inner skin is provided) (compartments of double skin side are designed for the of carriage cargo, fuel oil or water ballast):		
2.3.1	freeboard:		
	.1 tanks filled with fuel oil	0,15	0,15

	.2 tank for reception of water ballast	0,15	0,15
2.3.2	in the region of alternating waterlines:		
	.1 tanks filled with fuel oil	0,15	0,15
	.2 tank for reception of water ballast	0,15	0,15
2.3.3	below the region of alternating waterlines:		
	.1 tanks filled with fuel oil	0,15	0,15
	.2 tank for reception of water ballast	0,15	0,15
3	Bottom plating		
3.1	Bottom (inner bottom is not provided):		
3.1.1	including bilge	0,12	–
3.1.2	in way of cargo tanks	–	0,15
3.1.3	in way of fuel oil tanks	0,15	0,15
3.1.4	in way of ballast compartments	0,15	0,15
3.2	Bottom (inner bottom is provided):		
3.2.1	including bilge	0,12	0,12
3.2.2	in way of cargo tanks	0,15	0,15
3.2.3	in way of ballast compartments	0,15	0,15
4	Plating of inner bottom, hopper tank and trapezoidal stools under transverse bulkheads		
4.1	Inner bottom in the area of cargo holds (tanks):		
4.1.1	in way of fuel oil tanks	0,12	0,15
4.1.2	in way of ballast compartments	0,15	0,15
4.1.3	in way of boiler room	0,17	0,17
4.1.4	in way of engine room	0,10	0,17
4.1.5	with no wood sheathing in holds if cargo is expected to be discharged by grabs	0,17	0,17
4.2	Hopper tanks, trapezoidal stools under transverse bulkheads, margin plate:		
4.2.1	plating of hopper tanks and trapezoidal stools:		
	bottom strake	0,17	0,17
	other strakes	0,12	0,15
4.2.2	margin plate (inclined and horizontal)	0,17	0,17
4.2.3	margin plate in boiler room:		
	inclined	0,17	0,17
	horizontal	0,17	0,17
5	Plating of longitudinal and transverse bulkheads of inner skin		
5.1	Watertight bulkheads:		
5.1.1	top strake	0,10	–
5.1.2	middle strake	0,12	–
5.1.3	bottom strake	0,13	–
5.2	Bulkheads between holds loaded with bulk cargoes:		
5.2.1	top strake (0,1 <i>D</i> from the upper deck)	–	0,13
5.2.2	other strakes	–	0,15
5.3	Bulkheads between holds loaded with oil cargo or bulk cargo:		
5.3.1	top strake (0,1 <i>D</i> from the upper deck)	–	0,16
5.3.2	other strakes	–	0,18
5.4	Bulkheads between cargo tanks:		
5.4.1	top strake (0,1 <i>D</i> from the upper deck)	–	0,13 ¹
5.4.2	middle strake	–	0,10 ¹
5.4.3	bottom strake	–	0,13
5.5	Bulkheads between cargo and ballast compartments:		
5.5.1	top strake (0,1 <i>D</i> from the upper deck)	0,13	0,15
5.5.2	middle strake	0,15	0,15
5.5.3	bottom strake	0,15	0,17
5.6	Topside tanks	0,12	0,15
6	Framing of decks and platforms		
6.1	Deck longitudinals and beams of decks and platforms forming boundaries of:		
6.1.1	holds loaded with general cargoes	0,12	–
6.1.2	holds loaded with bulk cargoes	–	0,15
6.1.3	holds loaded with crude oil and petroleum products or bulk cargoes	–	0,15 ¹

6.1.4	cargo tanks	–	0,15
6.1.5	fuel oil tanks	0,15	0,15
6.1.6	ballast compartments	0,15	0,15
6.2	Deck girders, transverses of decks and platforms forming boundaries of:		
6.2.1	holds loaded with general cargoes	0,08	–
6.2.2	holds loaded with bulk cargoes	–	0,12
6.2.3	holds loaded with crude oil and petroleum products or bulk cargoes	–	0,15
6.2.4	cargo tanks	–	0,15 ¹
6.2.5	fuel oil tanks	0,10	0,10
6.2.6	ballast compartments	0,10	0,10
6.3	Cargo hatch coamings	0,08	0,10
7	Framing of sides and bulkheads		
7.1	Longitudinals, main and web frames, cross ties, vertical stiffeners and horizontal girders of sides and bulkheads forming boundaries of:		
7.1.1	holds loaded with general cargoes	0,10	–
7.1.2	holds loaded with bulk cargoes	–	0,13
7.1.3	holds loaded with crude oil and petroleum products or bulk cargoes	–	0,15
7.1.4	cargo tanks	–	0,15 ¹
7.1.5	fuel oil tanks	0,15	0,15
7.1.6	ballast compartments	0,15	0,15
8	Framing of bottom and inner bottom		
8.1	Bottom centre girder, side girders, floors and bottom longitudinal girders (inner bottom is omitted):		
8.1.1	in general cargo compartments	0,14	–
8.1.2	in cargo tanks	–	0,15
8.1.3	in ballast compartments	0,15	0,15
8.1.4	under the boilers	0,17	0,17
8.2	Bottom centre girder, side girders, floors, bottom and inner bottom longitudinals in double bottom compartments:		
8.2.1	not intended to be filled	0,12	0,12
8.2.2	in oil fuel tanks	0,15	0,15
8.2.3	in water ballast tanks	0,15	0,17
8.2.4	under the boilers	0,17	0,17
9	Superstructures, deckhouses and bulwarks		
9.1	Shell plating	0,06	0,06
9.2	Framing	0,06	0,06

¹ – for tankers carrying crude oil, u is increased by 50 %.

1.1.5.3 The factors ω_k and j_k , taking into account corrosion allowance with regard to the cross-sectional area of the web and to the section modulus of members of rolled section are determined by the formulae:

.1 for rolled tee, angular and symmetrical flat bulb profile members:

$$\omega_k = \left(2,15 / \sqrt[3]{W'}\right) + \sqrt[3]{\Delta s / 2},$$

$$\omega_k = 0,1\Delta s + 0,96;$$

.2 for band and flat profile members

$$\omega_k = \left(0,85 / \sqrt[3]{W'}\right) + \sqrt[3]{\Delta s / 2},$$

but at least 1,05,

where W' – section modulus of the member under consideration in accordance with 1.6.4.2;

Δs – refer to 1.1.5.1;

$$j_k \approx \omega_k$$

1.1.6 Compliance with statutory requirements (for ships of gross tonnage 500 t and over).

1.1.6.1 In passenger ships, the keels of which were laid or which were at a similar stage of construction before 1 January 2009, the peak and machinery space bulkheads, shaft tunnels, etc. shall comply with the following requirements³.

.1 a fore peak or collision bulkhead shall be fitted which shall respectively be watertight up to the bulkhead deck. This bulkhead shall be located at a distance from the forward perpendicular of not less than 5 per cent of the length of the ship and not more than 3 m plus 5 per cent of the length of the ship. Where the stem forms the external contour of the hull from the forward end with no protruding parts except the bulbous bow, the forward perpendicular shall coincide with the forward edge of the stem on the level of the deepest subdivision load line;

.2 where any part of the ship below the waterline extends forward of the forward perpendicular, e.g. a bulbous bow, the distances stipulated in 1.1.6.1.1, shall respectively be measured from a point either at the midlength of such extension, or at a distance 1,5 per cent of the length of the ship forward of the forward perpendicular, or at a distance 3 m forward of the forward perpendicular, whichever gives the smallest measurement.

.3 where a long forward superstructure is fitted, the fore peak or collision bulkhead on all passenger ships shall respectively be extended weathertight to the next full deck above the bulkhead deck. The extension shall be so arranged as to preclude the possibility of the bow door causing damage to it in the case of damage to, or detachment of, the bow door.

.4 The extension required in 1.1.6.1.3 need not be fitted directly above the bulkhead below, provided that all parts of the extension are not located forward of the forward limit specified in 1.1.6.1.1 or 1.1.6.1.2.

However, in ships constructed before 1 July 1997:

.4.1 where a sloping ramp forms part of the extension, the part of the extension which is more than 2,3 m above the bulkhead deck may extend no more than 1 m forward of the forward limits specified in 1.1.6.1.1 or 1.1.6.1.2; and

.4.2 where the existing ramp does not comply with the requirements for acceptance as an extension to the collision bulkhead and the position of the ramp prevents the siting of such extension within the limits specified in 1.1.6.1.1 or 1.1.6.1.2, the extension may be sited within a limited distance aft of the aft limit specified in 1.1.6.1.1 or 1.1.6.1.2. The limited distance aft shall be no more than is necessary to ensure noninterference with the ramp.

The extension to the collision bulkhead shall open forward. The extension shall comply with the requirements of 1.1.6.1.3 and shall be so arranged as to preclude the possibility of the ramp causing damage to it in the case of damage to, or detachment of, the ramp.

.5 ramps that do not comply with the above requirements shall be disregarded as an extension of the collision bulkhead.

.6 in ships constructed before 1 July 1997, the requirements of 1.1.6.1.3 and 1.1.6.1.4 shall apply not later than the date of the first periodical survey after 1 June 1997.

.7 an after peak bulkhead dividing the engine room from the cargo and passenger spaces forward and aft, shall also be fitted and made watertight up to the bulkhead deck.

The after peak bulkhead may, however, be stepped below the bulkhead deck, provided the degree of safety of the ship as regards subdivision is not thereby diminished.

.8 in all cases sterntubes shall be enclosed in watertight spaces of moderate volume. The stern gland shall be situated in a watertight shaft tunnel or other watertight space separate from the sterntube compartment and of such volume that, if flooded by leakage through the stern gland, the margin line will not be submerged.

1.1.6.2 In cargo ships, other than tankers, the keels of which were laid or which were at a similar stage of construction before 1 January 2009, as well as in tankers irrespective of the construction date the peak and machinery space bulkheads, stern tubes shall comply with the following requirements⁴.

³ For the purpose of this paragraph, "length of ship" is the length measured between perpendiculars from the extreme points of the ship on the level of the deepest subdivision load line. For the definitions of the deepest subdivision load line refer to 1.2, Part V "Subdivision".

⁴ For the purpose of the present paragraph "freeboard deck", "length of ship" and "forward perpendicular" have the meanings as defined in the International Convention on Load Lines, 1966 (LL-66), as modified by the Protocol of 1988 relating thereto (revised in 2003) Rule 3 Annex I.

.1 a collision bulkhead shall be fitted which shall be watertight up to the freeboard deck. This bulkhead shall be located at a distance from the forward perpendicular of not less than 5 per cent of the length of the ship or 10 m, whichever is the less, in separate cases other value may be permitted, but not more than 8 per cent of the length of the ship.

.2 where any part of the ship below the waterline extends forward of the forward perpendicular, e.g. a bulbous bow, the distances stipulated in 1.1.6.2.1 shall be measured from a point either at the midlength of such extension, or at a distance 1,5 per cent of the length of the ship forward of the forward perpendicular, or at a distance 3 m forward of the forward perpendicular, whichever gives the smallest measurement.

.3 the bulkhead may have steps or recesses provided they are within the limits prescribed in 1.1.6.2.1 or 1.1.6.2.2.

.4 where a long forward superstructure is fitted, the collision bulkhead shall be extended weathertight to the deck next above the freeboard deck. The extension need not be fitted directly above the bulkhead below provided it is located within the limits prescribed in 1.1.6.2.1 or 1.1.6.2.2 with the exemption permitted by 1.1.6.2.5 and the part of the deck which forms the step is made effectively weathertight.

.5 where bow doors are fitted and a sloping loading ramp forms part of the extension of the fore peak bulkhead above the freeboard deck, the part of the ramp which is more than 2,3 m above the freeboard deck may extend forward of the limit specified in 1.1.6.2.1 or 1.1.6.2.2. The ramp shall be weathertight over its complete length.

.6 the number of openings in the extension of the fore peak bulkhead above the freeboard deck shall be restricted to the minimum compatible with the design and normal operation of the ship.

.7 bulkheads shall be fitted separating the engine room from cargo and passenger spaces forward and aft and made watertight up to the freeboard deck.

.8 sterntubes shall be enclosed in a watertight space (or spaces) of moderate volume. Other measures may be taken to minimize the danger of water penetrating into the ship in case of damage to sterntube arrangements.

1.1.6.3 In passenger ships and cargo ships, other than tankers, the keels of which were laid or which were at a similar stage of construction on 1 January 2009 or after that date, the peak and machinery space bulkheads, shaft tunnels, etc. shall comply with the following requirements.

.1 a collision bulkhead shall be fitted which shall be watertight up to the bulkhead deck. This bulkhead shall be located at a distance from the forward perpendicular of not less than 5 per cent of the length of the ship or 10 m, whichever is the less, and if other value is not permitted, not more than 8 per cent of the length of the ship or 3 m plus 5 per cent of the length of the ship, whichever is the greater.

.2 where any part of the ship below the waterline extends forward of the forward perpendicular, e.g. a bulbous bow, the distance stipulated in 1.1.6.3.1, shall be measured from a point either at the midlength of such extension, or at a distance 1,5 per cent of the length of the ship forward of the forward perpendicular, or at a distance 3 m forward of the forward perpendicular, whichever gives the smallest measurement.

.3 the bulkhead may have steps or recesses provided that they are within the limits prescribed in 1.1.6.3.1 or 1.1.6.3.2.

.4 no doors, manholes, access openings, ventilators or any other openings shall be fitted in the collision bulkhead below the bulkhead deck.

.5 except as provided in 1.1.6.3.6, the collision bulkhead may be pierced below the bulkhead deck by not more than one pipe for dealing with the forepeak tank, provided that the pipe is fitted with a screwdown valve capable of being operated from above the bulkhead deck, the valve chest being secured inside the forepeak tank to the collision bulkhead. This valve may be fitted on the after side of the collision bulkhead provided that the valve is readily accessible under all service conditions and the space in which it is located is not a cargo space. All valves shall be of steel, bronze or other approved ductile material. Valves of ordinary cast iron or similar material are not acceptable.

.6 if the forepeak is divided to hold two different kinds of liquids, the collision bulkhead to be pierced below the bulkhead deck by two pipes, each of which is fitted as required by 1.1.6.3.5, provided that there is no practical alternative to the fitting of such a second pipe and that, having regard to the additional subdivision provided in the forepeak, the safety of the ship is maintained.

.7 where a long forward superstructure is fitted, the collision bulkhead shall be extended weathertight to the deck next above the bulkhead deck. The extension of the collision bulkhead need not be fitted directly above the bulkhead below provided it is located within the limits prescribed in 1.1.6.3.1 or 1.1.6.3.2, with the exemption permitted by 1.1.6.3.8, and the part of the deck which forms the step is made effectively weathertight. The extension shall be so arranged as to preclude the possibility of the bow door causing damage to it in the

case of damage to, or detachment of, the bow door.

.8 where bow doors are fitted and a sloping loading ramp forms part of the extension of the collision bulkhead above the bulkhead deck, the ramp shall be weathertight over its complete length. In cargo ships, the part of the ramp which is more than 2,3 m above the bulkhead deck may extend forward of the limit specified in **1.1.6.3.1** or **1.1.6.3.2**. Ramps not meeting the above requirements shall be disregarded as an extension of the collision bulkhead.

.9 the number of openings in the extension of the collision bulkhead above the freeboard deck shall be restricted to the minimum compatible with the design and normal operation of the ship. All such openings shall be capable of being closed weathertight.

.10 bulkheads shall be fitted separating the machinery space from cargo and accommodation spaces forward and aft and made watertight up to the bulkhead deck.

In passenger ships, an afterpeak bulkhead shall also be fitted and made watertight up to the bulkhead deck. The afterpeak bulkhead may, however, be stepped below the bulkhead deck, provided the degree of safety of the ship as regards subdivision is not thereby diminished.

.11 in all cases stern tubes shall be enclosed in watertight spaces of moderate volume.

In passenger ships, the stern gland shall be situated in a watertight shaft tunnel or other watertight space separate from the stern tube compartment and of such volume that, if flooded by leakage through the stern gland, the bulkhead deck will not be immersed.

In cargo ships, other measures to minimize the danger of water penetrating into the ship in case of damage to stern tube arrangements may be taken.

.12 The ship shall be so designed that the factor s_i calculated in accordance with **2.5**, Part V is not less than 1 under load conditions at the highest draft of subdivision, under load conditions at trim or any forward trim, if any the part of the ship ahead of the collision bulkhead has been flooded without vertical borders.

1.1.6.4 In passenger ships, the keels of which were laid or which were at a similar stage of construction before 1 January 2009, the double bottom shall comply with the following requirements:

.1 a double bottom shall be fitted extending from the fore peak bulkhead to the after peak bulkhead as far as this is practicable and compatible with the design and proper working of the ship.

In ships of 50 m and upwards but less than 61 m in length a double bottom shall be fitted at least from the engine room to the fore peak bulkhead, or as near thereto as practicable.

In ships of 61 m and upwards but less than 76 m in length a double bottom shall be fitted at least outside the engine room, and shall extend to the fore and after peak bulkheads, or as near thereto as practicable.

In ships of 76 m in length and upwards, a double bottom shall be fitted amidships, and shall extend to the fore and after peak bulkheads, or as near thereto as practicable.

.2 where a double bottom is required to be fitted, its depth shall be in accordance with the requirements of **2.4.4.1**, and the inner bottom shall be continued out to the ship's sides in such a manner as to protect the bottom to the turn of the bilge. Such protection will be deemed satisfactory if the line of intersection of the outer edge of the margin plate with the bilge plating is not lower at any part than a horizontal plane passing through the point **A** at midship section, as shown in Fig. 1.1.6.4.2.

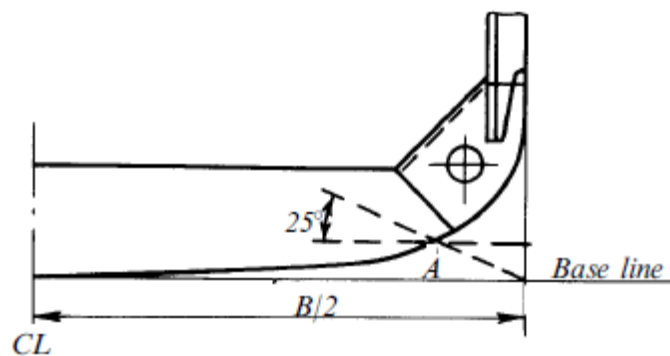

Fig. 1.1.6.4.2

.3 small wells constructed in the double bottom in connection with drainage arrangements of holds, etc. shall not extend downwards more than necessary. The depth of the well shall in no case be more than the depth less 460 mm of the double bottom at the centreline, nor shall the well extend below the horizontal plane referred to in 1.1.6.4.2. A well extending to the outer bottom is, however, permitted at the after end of the shaft tunnel. Other wells (e.g., for lubricating oil under main engines) may be permitted if the arrangements give protection equivalent to that afforded by a double bottom complying with the requirements of present paragraph.

.4 a double bottom need not be fitted in way of watertight compartments of moderate size used exclusively for the carriage of liquids, provided the safety of the ship, in the event of bottom or side damage, is not thereby impaired.

.5 In ships of restricted navigation area «**B-R3-S, B-R3-RS, C-R3-S, C-R3-RS and D-R3-S, D-R3-RS**» the Register may permit not to arrange a double bottom in any part of the ship, with subdivision index less than 0.50 if the arrangement of double bottom in this part of the ship is not compatible with her design and normal operation.

1.1.6.5 In cargo ships other than tankers, the keels of which were laid or which were at a similar stage of construction before 1 January 2009, the double bottom shall comply with the following requirements:

.1 a double bottom shall be fitted extending from the collision bulkhead to the after peak bulkhead, as far as this is practicable and compatible with the design and proper working of the ship.

.2 the double bottom depth shall be in conformity with 2.4.4.1, and the inner bottom shall be continued out to the ship's side in such a manner as to protect the bottom to the turn of the bilge.

.3 small wells constructed in the double bottom, in connection with the drainage arrangements of holds, shall not extend in depth more than necessary. A well extending to the outer bottom may, however, be permitted at the after end of the shaft tunnel of the ship. Other wells may be permitted if the arrangements give protection equivalent to that afforded by a double bottom complying with the present paragraph.

.4 a double bottom need not be fitted in way of watertight compartments used exclusively for the carriage of liquids, provided the safety of the ship in the event of bottom damage is not thereby impaired.

1.1.6.6 In passenger ships and cargo ships, other than tankers, the keels of which were laid or which were at a similar stage of construction on 1 January 2009 or after that date, the double bottom shall comply with the following requirements:

.1 a double bottom shall be fitted extending from the collision bulkhead to the after peak bulkhead, as far as this is practicable and compatible with the design and proper working of the ship.

.2 the double bottom depth shall be in accordance with the requirements of 2.4.4.1 and the inner bottom shall be continued out to the ship's sides in such a manner as to protect the bottom to the turn of the bilge.

But in any case the height of double bottom shall be at least 0.76 m, and is not required more than 2.0 m.

.3 small wells constructed in the double bottom, in connection with the drainage arrangements of holds, etc. shall not extend downward more than necessary.

In no case shall the vertical distance from the bottom of such a well to a plane coinciding with the keel line be not less than $h/2$ or 500 mm whichever is greater, or whether the requirements of 2.9, Part V, for this part of the ship have been established.

.3. Other wells (e.g., for lubricating oil under main engines) may be permitted if the arrangements give protection equivalent to that afforded by a double bottom complying with the present paragraph.

.3.2 For a cargo ship with a length of 80 m and over or for a passenger ship it shall be demonstrated that the ship is capable of withstanding bottom damages as specified in **2.9**, Part V.

Alternatively, lubricating oil wells under main engines may extend into the double bottom below the boundary line, which is determined by the distance h , provided, the vertical distance from the bottom of such a well to a plane coinciding with the keel line be not less than $h/2$ or 500 mm whichever is greater.

.3.3 For a cargo ship with a length of 80 m such devices shall provide a level of safety satisfactory to the Administration.

.4 a double bottom need not be fitted in way of watertight compartments of moderate size used exclusively for the carriage of liquids, provided the safety of the ship, in the event of bottom or side damage, is not thereby impaired.

.5 any part of a passenger ship or a cargo ship that is not fitted with a double bottom in accordance with **1.1.6.6.1** or **1.1.6.6.4** shall comply with the requirements of **2.9**, Part V "Subdivision".

.6 in case of unusual bottom arrangement in a passenger ship or a cargo ship it shall be demonstrated that the ship is capable of withstanding bottom damages as specified in **2.9.3**, Part V "Subdivision".

1.1.6.7 The freeing ports in bulwarks shall be assigned proceeding from **3.2.13** of the Load Line Rules for Sea-Going Ships.

The lower edges of freeing ports shall be arranged as near to the deck as practicable, but they shall not bear upon the sheerstrake.

In ships of 65 m in length and upwards a continuous slot shall generally be provided between the freeboard and sheerstrake edge instead of freeing ports.

1.1.6.8 In passenger ships and cargo ships, the design of watertight decks, trunks, etc. shall comply with the following requirements.

.1 watertight decks, trunks, tunnels, duct keels and ventilation ducts shall have a strength equal to that of watertight bulkheads fitted on the same level. Watertight ventilation ducts and trunks shall be carried at least to the bulkhead deck in passenger ships and at least to the freeboard deck in cargo ships.

.2 where a ventilation trunk passing through a structure penetrates the bulkhead deck, the trunk shall be capable of withstanding the water pressure that may be present within the trunk, after having taken into account the maximum heel angle allowable during intermediate stages of flooding, in accordance with **3.3.3**, Part V "Subdivision".

.3 where all or part of the penetration of bulkhead deck is on the main ro-ro deck, the trunk shall be capable of withstanding impact pressure due to internal water motions of the trapped water on the vehicle deck.

1.2 MATERIALS

1.2.1 General.

The materials used for hull structures regulated by this Part of the Rules shall comply with the requirements of Part XIII "Materials".

1.2.2 Steel grades for hull structures.

1.2.2.1 Hull members shall be fabricated of mild steel grades A, B, D and E with the upper yield stress $R_{eH} = 235$ MPa and of AH, DH, EH and FH high tensile steel grades A32, D32, E32 and F32 with the upper yield stress $R_{eH} = 315$ MPa; A36, D36, E36 and F36 steel grades with the upper yield stress $R_{eH} = 355$ MPa, and A40, D40, E40 and F40 steel grades with the upper yield stress $R_{eH} = 390$ MPa.

The application of high strength steel grades D, E, F with the upper yield stress of 420 MPa and above is subject to special consideration by the Register in each case.

1.2.2.2 In case of high local stresses in the thickness direction, Z-steel (refer to **3.14**, Part XII I "Materials") shall be used for the fabrication of structural members having a thickness in excess of 18 mm unless no measures are taken to structurally prevent lamellar tearing.

1.2.2.3 Where clad steel is used, the mechanical properties of the base material shall not be lower than those required for the steel grade specified in **1.2.3.1**.

Hull structural steel stated in **3.17**, Part XIII "Materials" shall be used as the base material.

1.2.3 Selection of steel grades for hull structures.

1.2.3.1 Steel grades for hull structural members shall be selected according to **1.2.3.7**, whereas steel grades for structural members designed for prolonged exposure to low service temperatures according to Figs. 1.2.3.1-1 _ 1.2.3.1-3 shall be selected for various Classes of structural members proceeding from the actual thickness adopted for the member concerned and the design temperature of structures to be determined by a procedure agreed with the Register.

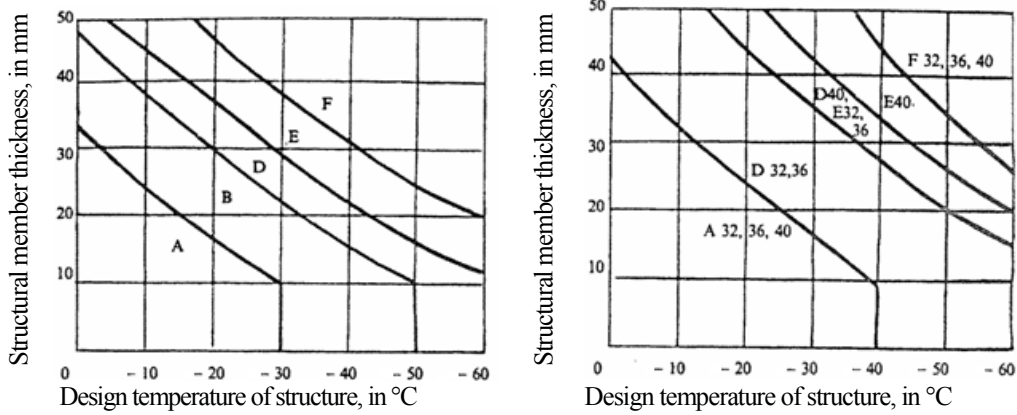

Fig. 1.2.3.1-1 Structural members of Class I

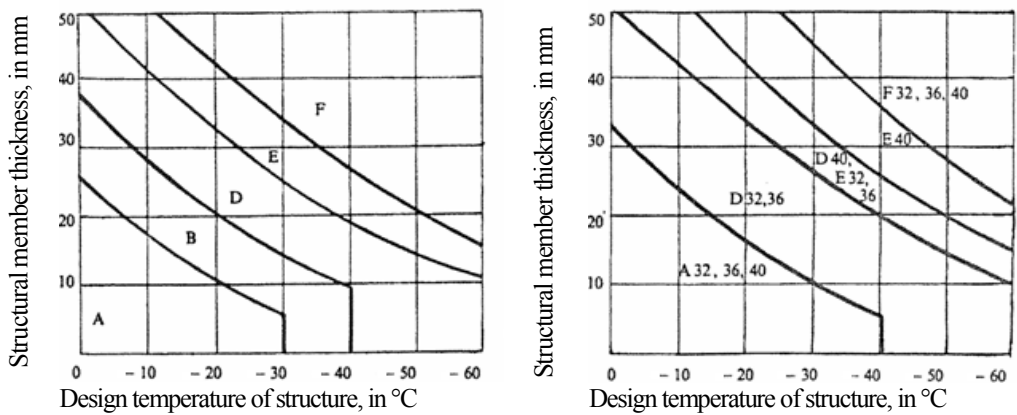

Fig. 1.2.3.1-2 Structural members of Class II

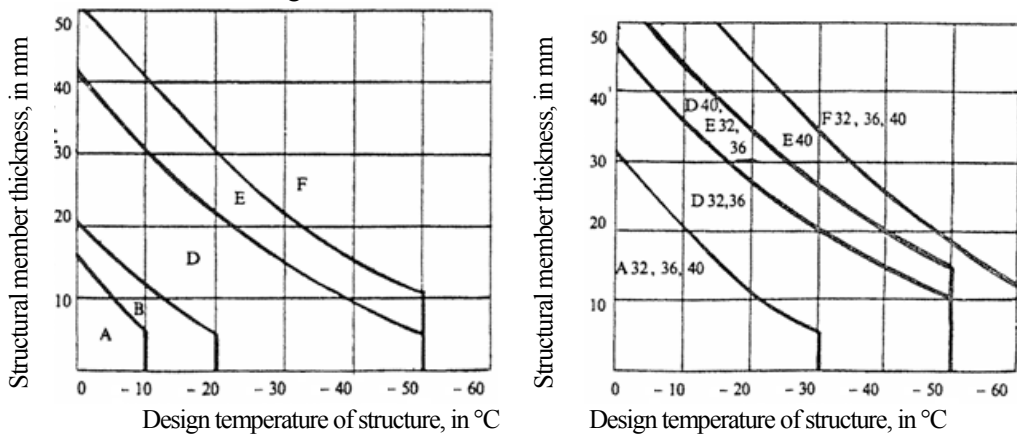

Fig. 1.2.3.1-3 Structural members of Class III

1.2.3.2 The design temperature of the structures which come constantly or periodically in contact with ambient air are expressed in terms of minimum design temperature of ambient air T_A .

In the absence of any other provisions, for the value of T_A the minimum average daily air temperature is adopted which can take place during a five-year period of operation on the routes passing in the most unfavourable waters as regards cooling conditions.

1.2.3.3 In all cases the value of T_A shall not exceed:

- 40 °C⁵ – for icebreakers of ice classes **Icebreaker2**, **Icebreaker3**, **Icebreaker4** and ships of ice classes **Ice6**, **Ice5**;
 – 30 °C – for icebreakers of ice class **Icebreaker1** and ships of ice class **Ice4**;
 – 10 °C – for ships of ice classes **Ice3**, **Ice2**.

For ships of polar classes, Baltic ice classes **IC** ÷ **IA Super** and other ice classes equipped to provide continuous operation at low temperatures with assigning **WINTERIZATION(DAT)** sign, the value of T_A is set according to the estimated outside temperature according to the sign (refer to 3.16.2).

1.2.3.4 An approximate determination of temperatures of structures is permitted based on the values of T_A obtained by this method in accordance with the recommendations given in Table.

Table 1.2.3.4

Hull structure	Operation conditions		Design temperature t_p		
	Insulation	Heating	Cargo space region		Region of spaces other than cargo spaces
			tanks	holds	
Exposed part of strength deck, side plating portion above summer load waterline (for ice class ships — above ice belt) as well as adjacent framing and portions up to 1,0 m wide of bulkhead structures, decks, platforms, topside tanks, etc.	Fitted	Not provided	T_A		
	–	Fitted	$0,50 T_A$		
	Not provided	Not provided	$0,70 T_A$	$T_A + 5$ °C	$0,60 T_A$
Strength deck portion under unheated superstructures.	–	Not provided	–10 °C		
External structures of superstructures and deckhouses.	Fitted	Fitted	$0,50 T_A$		
		Not provided	$0,70 T_A$		
Structures cooled on both sides with ambient air	Not provided	Not provided	T_A		
Side plating portion in the region of alternating waterline. Ice belt of ice class ships	Fitted	Not provided	$0,55 T_A$		
	–	Fitted	$0,35 T_A$		
	Not provided	Not provided	$0,40 T_A$		

Notes to Table 1.2.3.4 :

1. For external structures of underwater portion of the hull $t_p = 0$ °C.
2. "–" means that the isolation does not affect the design temperature T_p .

1.2.3.5 At the design tensile stresses in the upper deck and side longitudinals (of sheerstrake) due to the still water hogging moment (σ_{sw}), exceeding the value $65/\eta$, the design temperature of longitudinals may be corrected by the value of

$$\Delta T_p = -10(\sigma_{sw}/65 - 1), \text{ °C.}$$

1.2.3.6 The design temperature of hull structures located within the refrigerated cargo spaces shall be assumed equal to the temperature in the refrigerated cargo space.

The design temperature of the structures forming boundaries of the refrigerated cargo spaces shall be

⁵ When operating with calls at the mouth of the northern rivers the value of T_A shall not exceed –50 °C.

assumed as follows:

with no insulation fitted on the side of the refrigerated cargo space, the temperature in this space;

with insulation fitted on the side of the refrigerated cargo space and with no insulation on the other side, the temperature on the uninsulated side of the boundary in the space;

with insulation fitted on both sides, arithmetical mean of the temperatures in the adjacent spaces.

1.2.3.7 Depending on the level and type of applied stress, presence of stress concentrations, complexity of structural design of the assemblies and the workmanship, the assumed damage consequences for safety of the ship as a whole, the structural members are grouped into three Classes according to Table 1.2.3.7-1.

The steel grade of structural members shall not be below the grade specified in Tables 1.2.3.7-1 _ 1.2.3.7-6. Additional requirements:

for single deck ships with length exceeding 150 m, excluding those covered in Table 1.2.3.7-3, are given in Table 1.2.3.7-2;

for membrane type liquefied gas carriers with length exceeding 150 m are given in Table 1.2.3.7-3;

for ships with length exceeding 250 m are given in Table 1.2.3.7-4;

for ships with ice strengthening are given in Table 1.2.3.7-5.

The steel grade depending on the structural member thickness is determined in accordance with Table 1.2.3.7-6.

Table 1.2.3.7-1

Nos	Structural member category	Material class/grade	
1	2	3	
1	Longitudinal bulkhead strakes, other than that given in para 7	Class I throughout the length of a ship	
2	Deck plating exposed to weather, other than that given in paras 5, 12, 13, 15 and 16		
3	Side plating		
4	Bottom plating, including keel plate	Class II amidships. Class I outside of amidships.	
5	Strength deck plating, excluding that given in paras 12, 13, 14, 15 and 16		
6	Continuous longitudinal plating of strength members above strength deck, excluding hatch coamings		
7	Uppermost strake in longitudinal bulkhead		
8	Vertical strake (hatch side girder) and uppermost sloped strake in top wing tank		
9	Longitudinal hatch coamings of length less than $0,15L$		
10	External longitudinal members, plating and framing of long superstructures and plating of sides of short superstructures and deckhouses (first tier)		
11	Sheerstrake ¹ .		Class III amidships Class II outside of amidships Class I outside $0,6L$ amidships
12	Stringer plate in strength deck ¹ .		
13	Deck strake at longitudinal bulkhead, excluding deck plating in way of inner-skin bulkhead of double-hull ship ¹ .		
14	Lower deck strakes at cargo hatch corners in refrigerated spaces ² .		
15	Strength deck plating at outboard corners of cargo hatch openings in container carriers and other ships with similar hatch opening configurations	Class III amidships Class II outside of amidships Class I outside $0,6L$ amidships Class III within cargo region.	
16	Strength deck plating at corners of cargo hatch openings in bulk carriers, ore carriers, combination carriers and other ships with similar hatch opening configurations.		
17	Trunk deck and inner deck plating at corners of openings for liquid and gas domes in membrane type liquefied gas carriers	Class III within $0,6L$ of the ship Class II within rest of cargo region.	
18	Bilge strake in ships with double bottom over the full breadth and		

	length less than 150 m ¹	Class I outside 0,6L amidships.
19	Bilge strake in other ships ¹	Class III amidships Class II outside of amidships Class I outside 0,6L amidships.
20	Longitudinal hatch coamings of length greater than 0,15L, including coaming top plate and flange.	Class III amidships Class II outside of amidships Class I outside 0,6L amidships. ³
21	End brackets and deck house transition of longitudinal cargo hatch coamings.	
22	Side plating at cargo port corners	Class II throughout the length of a ship
23	Plating and framing (welded members) in ice-strengthening region I (refer to Figs. 3.10.1.3.2 and 3.10.1.3.3), welded plate stems and stern frames of: .1 ships of ice classes Ice4, Ice3, Ice2, Ice1 .2 ships of ice classes Ice6, Ice5 and icebreakers irrespective of ice class	Class I throughout the length of a ship Class II throughout the length of a ship
24	Rolled section framing of: .1 ships irrespective of ice class and icebreakers of ice class Icebreaker1 .2 icebreakers of ice classes Icebreaker2, Icebreaker3, Icebreaker4	Class I throughout the length of a ship Class II throughout the length of a ship

¹ Single strakes required to be of Class III within 0,4Z amidships shall have breadths not less than 800+ 5L mm, need not be greater than 1800 mm, unless limited by the geometry of the ship's design.
² The boundaries of areas for members related to this category correspond to Fig. 1.2.3.7.
³ Not to be less than Grade D/D H

Table 1.2.3.7-2

Structural member category	Material grade
Longitudinal plating of strength deck where contributing to the longitudinal strength.	Grade B/AH amidships.
Continuous longitudinal plating of strength members above strength deck.	Grade B/AH amidships.
Single side strakes for ships without inner continuous longitudinal bulkhead(s) between bottom and the strength deck.	Grade B/AH within cargo region

Table 1.2.3.7-3*

Structural member category	Material class/grade	
Longitudinal plating of strength deck where contributing to the longitudinal strength.	Grade B/AH amidships.	
Continuous longitudinal plating of strength members above the strength deck	Trunk deck plating	Class II amidships.
	Inner deck plating. Longitudinal strength member plating between the trunk deck and inner deck	Grade B/AH amidships.

* Table is applicable to similar ship types with a "double deck" arrangement above the strength deck

Table 1.2.3.7-4

Structural member category	Material grade
Sheerstrake at strength deck ¹ .	Grade E/EH amidships
Stringer plate in strength deck ¹ .	Grade E/EH amidships
Bilge strake ¹	Grade D/DH amidships

¹ Single strakes required to be of Grade E/EH and have breadths not less than $800 + 5L$ mm, need not be greater than 1800 mm, unless limited by the geometry of the ship's design.

Table 1.2.3.7-5

Structural member category	Material grade
Shell strakes in way of ice strengthening area for plates.	Grade B/AH.

Table 1.2.3.7-6

Structural member thickness S , in mm	Class, hull member is related to					
	I		II		III	
	Mild steel	High tensile steel	Mild steel	High tensile steel	Mild steel	High tensile steel
$S \leq 15,0$	A	AH	A	AH	A	AH
$15 < S < 20$			B	DH		
$20 < S < 25$			B	DH		
$25 < S < 30$			D	DH		
$30 < S < 35$	B	DH	E	EH	E	EH
$35 < S < 40$					D	DH
$40 < S < 50$	D	DH	E	EH		

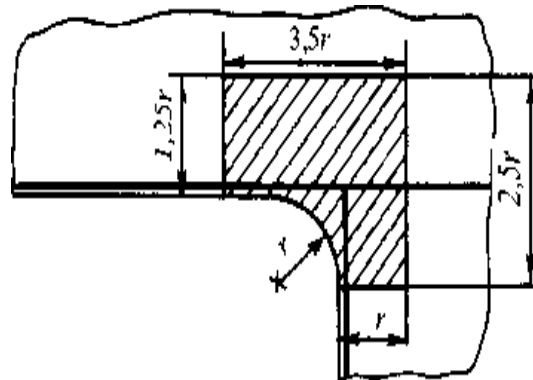

Fig. 1.2.3.7. Areas of cargo hatch corners (lined) belonging to members referred to Class III.

1.2.3.8 Structural members not mentioned in Tables 1.2.3.7-1 - 1.2.3.7-5, whose scantlings are regulated by this Part, shall be referred to Class I.

The steel grade shall correspond to the as-built plate thickness and material class.

1.2.3.9 For structures with high level of stress concentration, subject to dynamic loads (e.g. when mooring at sea) or being in combined stress state, the use of steel grade D or grade E may be required.

Steel grade A is not permitted.

1.2.3.10 Single strakes required to be of Class III or steel grade E/EH and have breadths not less than $800 + 5L$ mm, need not be greater than 1800 mm.

1.2.3.11 For ships less than 40 m in length, steel specified for Classes of structural members outside amidships according to Table 1.2.3.7-1 may be used throughout the length of the ship.

1.2.3.12 Plating materials for stern frames supporting the rudder and propeller boss, rudders, rudder horns and shaft brackets shall in general not be of lower grades than corresponding to Class II.

For rudder and rudder body plates subjected to stress concentrations (e.g. in way of lower support of semi spade rudders or at upper part of spade rudders), Class III shall be applied.

1.2.3.13 Steel grades for hull structural members of ships of 90 m in length and above, contributing to the hull strength may be selected in accordance with IACS unified requirement (UR) S6 taking into account **1.2.3.3**.

1.2.4 Aluminium alloys.

1.2.4.1 This Part of the Rules admits the following applications of aluminium alloys:

hull, superstructures and deckhouses, if $12 < L \leq 40$ m;

superstructures and deckhouses, if $L > 40$ m.

1.2.5 Anticorrosive protection and coatings.

1.2.5.1 Effective protective coatings complying with the requirements of **6.5.1.1**, Part XIII "Materials" shall be applied to the inner surfaces of ballast tanks. It is recommended to protect the inner spaces of cofferdams, duct keels, supports of transverse bulkheads and other similar void spaces of oil tankers and bulk carriers with protective coatings in accordance with **6.5.1.2**, Part XIII "Materials".

1.2.5.2 Anti-fouling coatings of ship hulls, in case of their application, shall comply with the requirements of **6.5.2**, Part XIII "Materials".

1.2.5.3 For cargo tanks of oil tankers of 5000 t deadweight and over carrying crude oil, one of the following effective measures on corrosion protection shall be implemented:

applying protective coatings in compliance with IMO resolution MSC.288(87) (refer to **6.5.1.2**, Part XIII "Materials");

using alternative means of protection or corrosion resistant materials to maintain the required structural integrity for 25 years in accordance with IMO resolution MSC.289(87) (refer to **3.16.1.2**, Part XIII "Materials").

1.3 DESIGN LOADS

1.3.1 General..

1.3.1.1 This Chapter contains the basic formulae for determining the design weather loads on hull, ship acceleration at motions as well as loads from dry and liquid cargoes.

1.3.1.2 Wave induced loads on the forward portion of the bottom and flare, loads from vehicles and deck heavy cargo as well as emergency loads are given in the chapters of this Part pertaining to the appropriate structures.

1.3.1.3 Rules of determining the load value and the load point are specified in the appropriate chapters pertaining to particular structures. In the absence of such provisions the load is assumed to be on the lower edge of the plate, at the middle of design span of the member or at the centre of the area taking up distributed load.

1.3.1.4 The basic parameter of design load and accelerations on ship's hull exposed to weather is the wave factor c_w , determined by the formulae:

$$c_w = 0,0856L \quad \text{for} \quad L \leq 90\text{m},$$

$$c_w = 10,75 - \{(300 - L) / 100\}^{3/2} \quad \text{for} \quad 90 < L < 300\text{m}, \quad (1.3.1.4)$$

$$c_w = 10,75 \quad \text{for} \quad 300 \leq L \leq 350\text{m}.$$

1.3.1.5 For ships of restricted area of navigation the wave factor c_w , shall be multiplied by the reduction factor φ_r , obtained from Table 1.3.1.5.

Table 1.3.1.5

Area of navigation	Factor φ_r ,
1	2
R1, A-R1	1
R2, A-R2	$1,25 - 0,25L \cdot 10^{-2} \leq 1$
R2-S**, R2-RS**, A-R2-S, A-R2-RS	$1,0 - 0,20L \cdot 10^{-2}$
R2-S (4,5), R2-RS (4,5)	$0,94 - 0,19L \cdot 10^{-2}$
R3-S, R3-RS, B-R3-S*, B-R3-RS*, C-R3-S, C-R3-RS	$0,86 - 0,18L \cdot 10^{-2}$
R3, R3-IN, D-R3-S, D-R3-RS	$0,75 - 0,18L \cdot 10^{-2}$
* For ships with a sign B-R3-S and B-R3-RS subject to the establishment of the area of operation with a wave	

height of at 3% provided between 3.5 m and 6.0 m, φ_r is determined by linear interpolation between the values for **R2-S** and **R2-RS** and **R3-S** and **R3-RS**, respectively to a specific waves height values.

** For ships with a sign **R2-S** and **R2-RS** subject to the establishment of the area of operation with a wave height of at 3% provided between 4,5 m and 6,0 m, φ_r is determined by linear interpolation between the values for **R2-S** and **R2-RS** and **R2-S(4,5)** and **R2-RS(4,5)**, respectively to a specific waves height values.

1.3.2 Wave loads.

1.3.2.1 The design pressure p , in kPa, acting on the ship's hull exposed to weather is determined by the following formulae:

for the points of application of the loads below the summer load waterline,

$$p = p_{st} + p_w ; \quad (1.3.2.1-1)$$

for the points of application of the loads above the summer load waterline,

$$p = p_w , \quad (1.3.2.1-2)$$

where p_{st} – static pressure, in kPa, determined by the formula

$$p_{st} = 10z_i;$$

z_i – distance form the point of application of the load to the summer load waterline, in m;

p_w – as defined in **1.3.2.2**.

1.3.2.2 The design pressure p_w , kPa, due to ship's hull motion about the wave contour is determined by the following formulae:

for the points of application of the loads below the summer load waterline:

$$p_w = p_{w0} \cdot [1 - 4,75 \cdot (d / L + B / 4L) \cdot (z_i / d)] \geq 0,5 \cdot p_{w0} \quad (1.3.2.2-1)$$

for the points of application of the loads above the summer load waterline:

$$p_w = p_{w0} - 7,5 a_x z_i \quad (1.3.2.2-2)$$

where: $p_{w0} = 5 c_w a_v a_x$;

c_w – refer to **1.3.1.4** i **1.3.1.5**;

$a_v = [0,8 \cdot v_0 \cdot (L / 10^3 + 0,4) / \sqrt{L}] + 1,5$;

$a_x = k_x (1 - 2 x_1 / L) \geq 0,267$;

k_x – factor equal to 0,8 and 0,5 for hull sections forward and aft of the midship section respectively;

x_1 – distance of the considered section from the nearest fore or after perpendicular, in m;

for z_i – refer to **1.3.2.1-2**;

v_0 – specific speed of the ship, in knots, see **1.1.3.6.3**.

In any case, the product $a_v a_x$ shall not be taken as less than 0,6.

Distribution of load p_w over the hull section contour is shown in Fig. 1.3.2.2.

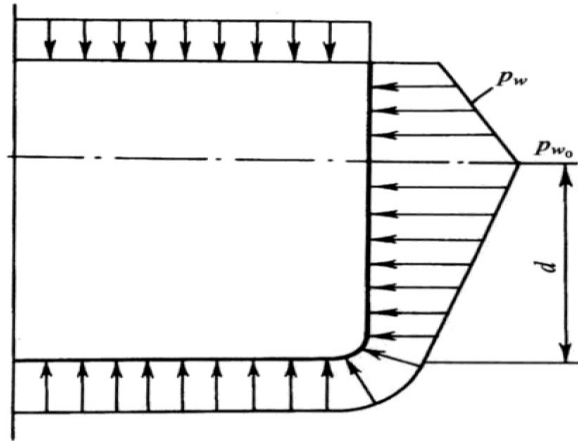

Fig. 1.3.2.2

1.3.3 Acceleration at motions.

1.3.3.1 Design acceleration a , in m/s^2 , at motions in waves is determined by the formula:

$$a = \sqrt{a_c^2 + a_K^2 + 0,4a_0^2}, \quad (1.3.3.1-1)$$

where: a_c – projection of ship's centre of gravity acceleration on the appropriate direction;

a_K, a_0 – projections of pitching and rolling acceleration on the appropriate directions at the point under consideration.

Acceleration projections for the considered member on the vertical (index z), horizontal-transverse (index y) and horizontal-longitudinal (index x) directions are determined by the following formulae:

$$\begin{aligned} a_{cx} &= 0,1(100/L)^{1/3}g\varphi_r; \\ a_{cy} &= 0,2(100/L)^{1/3}g\varphi_r; \\ a_{cz} &= 0,2(100/L)^{1/3}g\varphi_r; \\ a_{px} &= (2\pi/T_p)^2\psi z_0; \\ a_{py} &= 0; \\ a_{pz} &= (2\pi/T_p)^2\psi x_0; \\ a_{rx} &= 0; \\ a_{ry} &= (2\pi/T_r)^2\theta z_0; \\ a_{rz} &= (2\pi/T_r)^2\theta y_0 \end{aligned} \quad (1.3.3.1-2)$$

where: φ_r is given in Table 1.3.1.5 ($\varphi_r = 1$ – for ships of unrestricted service);

x_0 – distance of the considered point from the transverse plane passing through the ship's centre of gravity, in m;

y_0, z_0 – distance of the considered point from the centreline and the horizontal plane passing through the ship's centre of gravity respectively, in m;

T_p and T_r – pitching and rolling periods, in s, determined by the formulae:

$$\begin{aligned} T_p &= \frac{0,8\sqrt{L}}{1 + 0,4 \frac{v_0}{\sqrt{L}} \left(\frac{L}{10^3} + 0,4 \right)}; \\ T_r &= cB/\sqrt{h} \end{aligned} \quad (1.3.3.1-3)$$

3)

where: c – numerical factor determined on the basis of the data for the ship of similar type. As a first approximation, $c = 0,8$;

h – metacentric height for the most unfavourable conditions of operation; for a ship in fully loaded condition, $h \approx 0,07B$.

For a tanker in ballast condition T_r as a first approximation, can be determined by the formula:

$$T_r \approx 3\sqrt[3]{B};$$

ψ – design angle of trim, in rad, determined by the formula:

$$\psi = \varphi \frac{0,23}{1 + L \cdot 10^{-2}} \quad (1.3.3.1-4)$$

φ – refer to Table 1.4.4.3 ($\varphi = 1$ for ships of unrestricted service);

θ – design angle of heel, in rad., determined by the formula:

$$\theta = \varphi_r \frac{0,60}{1 + 0,5L \cdot 10^{-2}}, \quad (1.3.3.1-5)$$

If $L \leq 40$ m in Formulae (1.3.3.1-4) and (1.3.3.1-5), L shall be taken equal to $L = 40$ m.

At all types of motions, the total acceleration in the vertical direction a_z , in m/s^2 , can be determined by the formula:

$$a_z = g \frac{0,9}{\sqrt[3]{L}} (1 + k_a), \quad (1.3.3.1-6)$$

where $k_a = 1,6 (1 - 2,5x_1/L) \geq 0$ in the forward region;

$k_a = 0,5 (1 - 3,33x_1/L) \geq 0$ in the aft region;

x_1 – refer to 1.3.2.2.

If $L \leq 80$ m in Formula (1.3.3.1-6) shall be taken equal to tensile 80 m.

1.3.4 Cargo, fuel and ballast loads.

1.3.4.1 Design pressure p_c , kPa, on the grillages of cargo decks, platforms and double bottom from package cargo is determined having regard to inertia forces by the formula:

$$p_c = h \rho_c g \cdot (1 + a_z/g), \quad (1.3.4.1)$$

but not less than 20 kPa,

where h – design stowage height, in m;

ρ_c – density of the cargo carried, in t/m^3 ;

a_z – design acceleration in the vertical direction determined in accordance with **1.3.3.1**, in m/s^2 .

1.3.4.2 The design pressure on the structures forming boundaries of the compartments intended for the carriage of liquid cargoes and ballast in tankers, the ballast tanks in dry cargo ships as well as the tanks for ballast and fuel oil is determined depending on their dimensions, the extent of filling and the height of air pipe.

By compartment is meant a tank or a part of a tank confined between the effective bulkheads. Both watertight and wash bulkheads with the total area of openings not over 10 % of the bulkhead area are considered as effective bulkheads.

1.3.4.2.1 The design pressure p_c , in kPa, on the structures of fully loaded compartments is determined by the following formulae:

$$p_c = \rho_c g (1 + a_z/g) z_i, \quad (1.3.4.2.1-1)$$

$$p_c = \rho_c g (z_i + b \theta), \quad (1.3.4.2.1-2)$$

$$p_c = \rho_c g (z_i + l \psi), \quad (1.3.4.2.1-3)$$

$$p_c = 0,75 \rho_c g (z_i + \Delta z), \quad (1.3.4.2.1-4)$$

$$p_c = \rho_c g z_i + p_v, \quad (1.3.4.2.1-5)$$

where ρ_c – cargo, ballast or fuel density, in t/m^3 , whichever is appropriate;

a_z – design acceleration in the vertical direction according to 1.3.3.1;

z_i – distance, in m, from the member concerned to the deck level (tank top) as measured at the centreline;

θ and ψ – as determined by Formulae (1.3.3.1-4) and (1.3.3.1-5).

Δz – height, in m, of air pipe above deck (tank top), but shall not be less than: 1,5 m for the ballast tanks of dry cargo ships and for fresh water tanks, 2,5 m for the tanks of tankers and for fuel oil and lubricating oil tanks; for small expansion tanks and for lubricating oil tanks of less than 3 m^3 capacity, the minimum values of Δz are not stipulated;

p_v – pressure, in kPa, for which the safety valve is set, if fitted, but shall not be less than: 15 kPa for the ballast tanks of dry cargo ships and for fresh water tanks, 25 kPa for the tanks of tankers and for fuel oil and lubricating oil tanks; for small expansion tanks and for lubricating oil tanks of less than 3 m^3 capacity, the minimum values of p_c are not stipulated;

l and b – length and breadth, in m, of a compartment as measured at mid-height; if the values of l and/or b change abruptly over the compartment height, l and/or b are measured at midheight of each compartment section where their variation is not appreciable; the Formulae (1.3.4.2.1-2) and (1.3.4.2.1-3) are used for each measured value of l and b accordingly.

whichever is the greater.

1.3.4.2.2 Where a compartment shall be partially filled proceeding from service conditions, with the compartment length $l \leq 0,13L$ and compartment breadth $b \leq 0,6B$, the design pressure p_c , in kPa, for the structures mentioned below shall not be less than:

for the side, longitudinal bulkheads and adjoining compartment top within $0,25b$ of the line of compartment top and side intersection, or of the longitudinal bulkhead

$$p_c = \rho_c(5 - B/100)b; \quad (1.3.4.2.2-1)$$

for transverse bulkheads and adjoining compartment top within $0,25l$ of the line of compartment top and transverse bulkhead intersection

$$p_c = \rho_c(4 - L/200)l. \quad (1.3.4.2.2-2)$$

l and b shall be measured on the level of the free surface of liquid.

For compartments where $l > 0,13L$ and/or $b > 0,6B$, the design pressure for the case of partial flooding is determined in accordance with a special procedure approved by the Register.

1.3.4.3 The design pressure p_c , in kPa, on structures bounding the bulk cargo hold is determined by the formula:

$$p_c = \rho_c \cdot g \cdot k_c \cdot (1 + a_z/g) \cdot z_i, \quad (1.3.4.3)$$

but not less than 20 kPa.

where for: ρ_c – refer to **1.3.4.1**, t/m³;

$k_c = \sin^2\alpha \cdot \operatorname{tg}^2(45 - \varphi_{i.f}/2) + \cos^2\alpha$, or $k_c = \cos 2\alpha$, whichever is the greater;

α – angle of web inclination to the base line, in deg.;

$\varphi_{i.f}$ – internal friction angle of bulk cargo, in deg.;

a_z – design acceleration in the vertical direction according to **(1.3.3.1-6)**, in m/s²;

z_i – vertical distance from the load application point to the free surface level of cargo, in m.

The pressure on the inner bottom is determined by Formula (1.3.4.3) where $k_c = 1$.

1.3.4.4 The design pressure from package cargo acting upon the structures in horizontal plane is determined with regard for inertia forces. In Formula (1.3.3.1-1) the acceleration in the horizontaltransverse direction is determined by the formula

$$a_y = \sqrt{a_{cy}^2 + (a_{ry} + g \sin \theta)^2}; \quad (1.3.4.4-1)$$

and in the horizontal-longitudinal direction

$$a_x = \sqrt{a_{cx}^2 + (a_{px} + g \sin \psi)^2}, \quad (1.3.4.4-2)$$

where θ , ψ – are determined by Formulae (1.3.3.1-4) and (1.3.3.1-5);

a_{cy} , a_{ry} , a_{cx} , a_{px} – refer to **1.3.3.1**.

1.4 LONGITUDINAL STRENGTH

1.4.1 General and definitions.

1.4.1.1 The requirements of this Chapter apply to ships of unrestricted service, including with A sign, and of restricted areas of navigation **R1**, **A-R1**, **R2** and **A-R2**, 65 m in length and upwards, as well as to ships of restricted areas of navigation **R2-S**, **R2-RS**, **A-R2**, **A-R2-S**, **A-R2-RS**, **B-R3-S**, **B-R3-RS**, **C-R3-S**, **C-R3-RS**, **R3-S**, **R3-RS**, **R3**, **R3-IN**, **D-R3-S** and **D-R3-RS**, 60 m in length and upwards, whose proportions are stated in **1.1.1.1**.

Ships with large deck openings and vessels of dredging fleet shall comply additionally with the requirements of **3.1** and **3.6** respectively.

The requirements of the this Chapter shall not apply to container ships and ships, dedicated primarily to carry their cargo in containers, both of 90 m in length and upwards and operated in unrestricted service. When assessing the longitudinal strength, the requirements of AICS UR S11A «Longitudinal strength standard for container ships» taking into account S34 (May 2015).

1.4.1.2 Hull structures of ships having:

.1 proportion:

$$L/B \leq 5,$$

$B/D \geq 2,5$ ((for ships of restricted areas of navigation **R2-S**, **R2-RS**, **A-R2**, **A-R2-S**, **A-R2-RS**, **B-R3-S**, **B-R3-RS**, **C-R3-S**, **C-R3-RS**, **R3-S**, **R3-RS**, **R3**, **R3-IN**, **D-R3-S** and **D-R3-RS** the ratio B/D is obtained from Table 1.1.1.1);

.2 block coefficient

$$C_b < 0,6;$$

.3 specified speed v_0 , exceeding the value of v , in knots, determined by the formula

$$v = k\sqrt{L},$$

where $k = 2,2$ if $L \leq 100$ m;

$$k = 2,2 - 0,25(L-100)/100 \text{ if } L > 100 \text{ m,}$$

as well as of ships carrying heated cargoes and ships of unusual design and/or type shall be subject to direct strength calculation according to the agreed procedur.

1.4.1.3 For longitudinal strength calculation, design loads shall include still water bending moments and shear forces, wave bending moments and shear forces, and for ships with large flare, bending moments due to wave impacts on the flare as well.

Design wave and impact loads may be calculated both from formulae given in these Rules and according to the approved procedure taking into consideration the rolling in waves, long-term distribution of wave conditions and area of navigation.

1.4.1.4 Downward shear forces are assumed to be taken as positive values and upward shear forces - as negative values.

The hogging bending moments are assumed to be taken as positive values and sagging bending moments - as negative values.

For the calculation of still water bending moment and shear force, transverse loads shall be integrated in the forward direction from the aft end of L ;

in this case, downward loads are assumed to be taken as positive values.

The sign conventions of still water bending moment and shear force are as shown in Fig. 1.4.1.4.

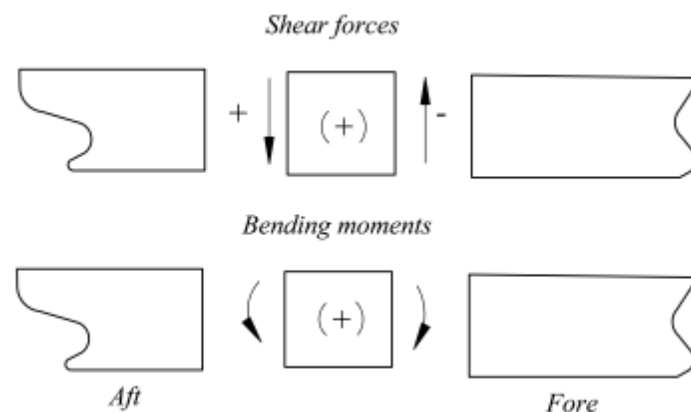

Fig.1.4.1.4

1.4.2 Symbols.

L_1 – length of the compartment considered, in m;

B_1 – breadth of the compartment considered, in m;

A_F - difference between the area of horizontal upper deck projection (including forecastle deck) and summer load waterline on a length up to $0,2L$ aft from the forward perpendicular, in m^2 ;

z_F – vertical distance from the summer load waterline to the upper deck (forecastle deck included), as measured on the forward perpendicular, in m;

I – actual inertia moment of the hull about the horizontal neutral axis of the hull section under consideration, in cm^4 ;

S – actual statical moment, about the neutral axis, of the portion of the considered hull section, located above or below the level at which the thickness of the web is determined, in cm^3 ;

x – distance of the considered hull section from the after perpendicular, in m.

1.4.3 Still water bending moments and shear forces.

1.4.3.1 The still water bending moments and shear forces shall be calculated for all actually possible cases of weight distribution over the length of the ship including full-load and ballast conditions for departure and arrival of the ship.

The bending moments and shear forces in the course of consuming the contents of each tank with ship's stores (fuel oil, water, lubricating oil) during voyage shall be also calculated if the above moments and forces exceed those for departure or arrival of the ship. The same applies to ship's ballasting/ deballasting at sea. In so doing, partially filled ballast tanks, including peak tanks, shall be ignored in the consideration excepting the following cases:

calculated bending moments and shear forces do not exceed the maximum design values at all levels of ballast tanks filling from an empty condition to full filling;

for bulk carriers, all intermediate conditions of ballast tanks filling from an empty condition to full filling with each cargo hold flooded are considered (refer to **3.3.5**).

As a rule, when determining the scantlings of framing members, consideration shall be given to the following loading conditions:

.1 for dry cargo ships, ships with large deck opening, roll-on/roll-off ships, refrigerated cargo ships, bulk carriers and ore carriers:

homogeneous loading conditions at maximum draught;

ballast condition;

special loading conditions:

light load conditions at less than the maximum draught, heavy cargo, empty holds or non-homogeneous cargo conditions, deck cargo conditions, etc., where applicable;

short voyage, where applicable;

loading and unloading transitory conditions;

docking condition (afloat);

.2 for oil tankers:

homogeneous loading conditions (excluding dry and clean ballast tanks);

partly loaded and ballast conditions for both departure and arrival;

any specified non-uniform distribution of loads;

mid-voyage conditions relating to tank cleaning or other operations where these differ significantly from the ballast conditions;

loading and unloading transitory conditions;

docking condition afloat;

.3 for combination carriers:

loading conditions as specified for dry cargo ships and oil tankers;

.4 ballast loading conditions where forepeak, afterpeak and/or other ballast tanks are partly filled at the departure, arrival or mid-voyage, shall not be considered as the design loading conditions. The exception shall be the cases where any partial filling of the tank does not exceed the permissible strength limitations. A notion "any partial filling" in the present paragraph assumes loading condition, which corresponds to an empty tank, fully loaded tank and a tank filled up to the prescribed level.

Where there are several partly loaded tanks, then all the combinations comprising empty, full and partly filled tanks shall be considered.

For ore carriers with large side ballast tanks in cargo area for the case where empty or full loading of one or maximum two pairs of these ballast tanks causes a trim exceeding at least one of the values mentioned below, then it shall be sufficient to demonstrate compliance with maximum, minimum and assigned partial filling levels of these one or maximum two pairs of side tanks, so that actual trim does not exceed any of these trim values. Fill up levels for the rest side ballast tanks shall be considered between full and empty. The above-mentioned trim values are as follows:

- trim by the stern for 3 % of ship length;

- trim by the bow for 1,5 % of ship length;

- any trim, at which propeller depth axis constitutes 25 % of its diameter.

Maximum and minimum filling levels of the above-mentioned one or maximum two pairs of side ballast tanks shall be included to the Loading Manual.

In cargo loading conditions, the requirements of the present paragraph apply to the peak tanks only.

The requirements of the present paragraph do not apply to ballast water exchange at sea using the sequential method. However, bending moment and shear force calculations for each ballasting or deballasting

stage in the ballast water exchange sequence shall be included in the Loading Manual or the Guidelines for Safe Ballast Water Exchange at Sea of any ship that intends to employ the sequential ballast water exchange method acty.

1.4.3.2 The maximum absolute values of sagging and hogging bending moments M_{sw} , and shear force N_{sw} shall be determined for any section along the ship's length for all the still water loading conditions, which are possible in service.

The values M_{sw} and N_{sw} are regarded further as design values for the section under consideration.

1.4.3.3 For ships without effective longitudinal bulkheads, with non-uniform distribution of loads, i.e. alternation of loaded and empty holds, the still water shear force curve may be corrected by reducing its ordinates on transverse bulkheads by a value equal to the total of bottom longitudinal responses in way of those bulkheads in the event of bottom bending (refer to Fig. 1.4.3.3).

The bottom longitudinal responses in way of transverse bulkheads shall be determined on the basis of the bottom grillage calculation in accordance with 3.3.4.1. The design loads to be considered shall not include the wave loads mentioned under 1.3.2.2, the angles of heel, trim and accelerations at motions determined in accordance with 1.3.3.1.

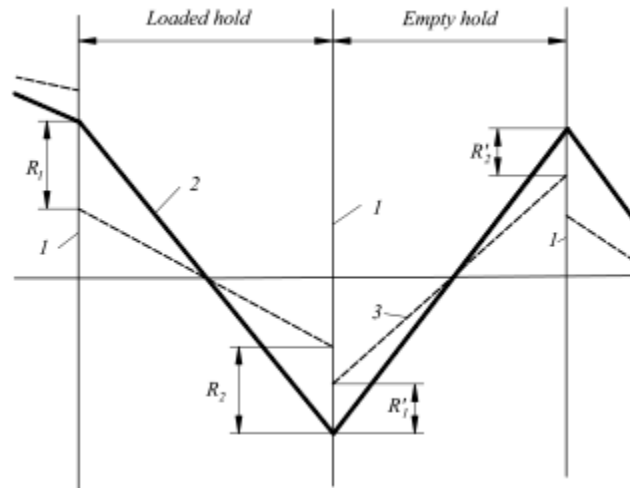

Fig.1.4.3.3. Shear force curve correction diagram

1 – transverse bulkhead; 2 – uncorrected curve; 3 – corrected curve;

R_1 and R_2 – total of bottom longitudinal responses for a loaded hold in way of aft bulkhead and forward bulkhead accordingly;

R'_1 and R'_2 – same for an empty hold.

1.4.3.4 Where provision is made in ship's design for loading conditions resulting in regular change of a sign of the still water bending moment (in fully loaded and ballast conditions on direct and return voyages), its components at the section with the maximum range of bending moment (refer to Fig. 1.4.3.4) shall be determined for use in the calculation under 1.4.6.3.

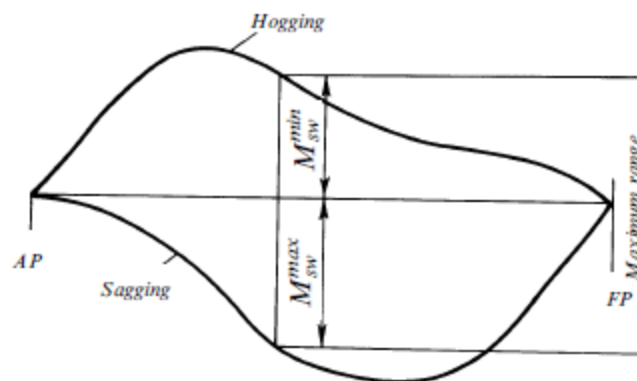

Fig. 1.4.3.4

1.4.4 Wave bending moments and shear forces.

1.4.4.1 The wave bending moment M_w , in kN/m, acting in the vertical plane at the section under consideration shall be determined by the formulae:

hogging bending moment

$$M_w = 190 c_w B L^2 C_b \alpha \cdot 10^{-3}; \quad (1.4.4.1-1)$$

sagging bending moment

$$M_w = -110 c_w B L^2 (C_b + 0,7) \alpha \cdot 10^{-3}, \quad (1.4.4.1-2)$$

where: c_w – as determined from 1.3.1.4;

α – coefficient determined from Table 1.4.4.1 and Fig. 1.4.4.1;

C_b – as defined in 1.1.3, but not less than 0,6.

Table 1.4.4.1

Position of section along the ship's length	α
$x/L < 0,4$	$2,5 x/L$
$0,4 \leq x/L \leq 0,65$	1
$x/L > 0,65$	$(1 - x/L) / 0,35$

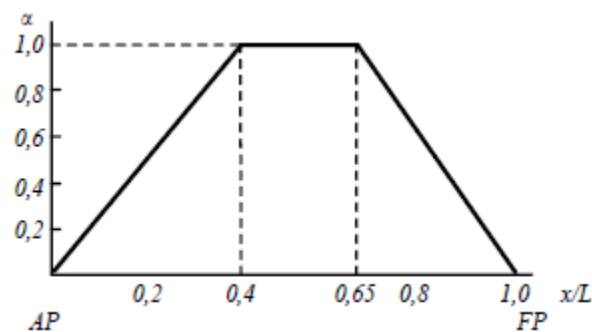

Fig. 1.4.4.1

1.4.4.2 The wave shear force N_w , in kN, at the section concerned shall be determined by the formulae: positive

$$N_w = 30 c_w B L (C_b + 0,7) f_1 \cdot 10^{-2}, \quad (1.4.4.2-1)$$

negative

$$N_w = -30 c_w B L (C_b + 0,7) f_2 \cdot 10^{-2}, \quad (1.4.4.2-2)$$

where c_w – as determined from 1.3.1.4;

C_b – as defined in 1.1.3, but not less than 0,6;

f_1 and f_2 – coefficients determined from Table 1.4.4.2, Figs. 1.4.4.2-1 and 1.4.4.2-2.

Table 1.4.4.2

Position of section along the ship's length	f_1	f_2
1	2	3
$0 \leq x/L < 0,2$	$4,6 f_0 x/L$	$4,6 x/L$
$0,2 \leq x/L \leq 0,3$	$0,92 f_0$	0,92

$0,3 < x/L < 0,4$	$0,7 + (9,2f_0 - 7)(0,4 - x/L)$	$1,58 - 2,2x/L$
$0,4 \leq x/L \leq 0,6$	0,7	0,7
$0,6 < x/L < 0,7$	$0,7 + 3(x/L - 0,6)$	$0,7 + (10f_0 - 7)(x/L - 0,6)$
$0,7 \leq x/L \leq 0,85$	1,0	f_0
$0,85 < x/L \leq 1,0$	$6,67(1 - x/L)$	$6,67(1 - x/L)f_0$
$f_0 = 190C_b / 110(C_b + 0,7)$		

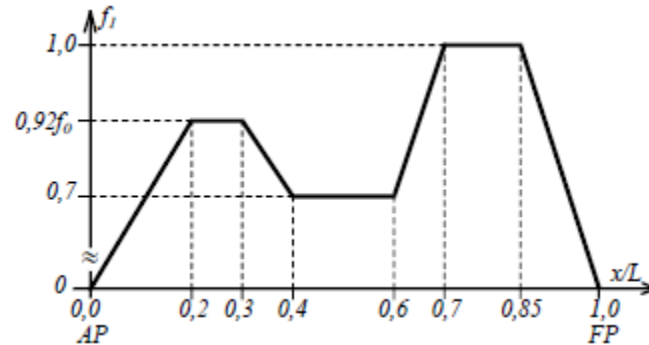

Fig.1.4.4.2-1

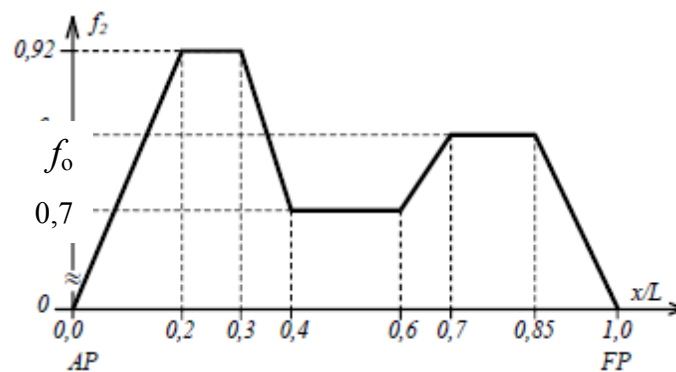

Fig.1.4.4.2-2

1.4.4.3 For ships of restricted area of navigation, the wave bending moments and shear forces determined in accordance with 1.4.4.1 and 1.4.4.2, shall be multiplied by the reduction factor ϕ , obtained from Table 1.4.4.3 as well as by the factors ψ and ν , determined by the following formulae:

$$\psi = (1 + \rho_n \cdot f \cdot 10^{-2}); \quad (1.4.4.3-1)$$

$$\nu = 1/(1+\Delta), \quad (1.4.4.3-2)$$

where: $\rho_n = \alpha^2 \cdot (0,5 + 2,5 \cdot \sin\beta_0) \geq \alpha -$ for conventional bow shape (no bulb);

$\rho_n = \alpha^2 \cdot (1 + \alpha^2) \geq 1 -$ for a bulbous bow;

α – waterplane area coefficient for summer load waterline;

β_0 – angle, in deg., between a frame tangential and a vertical at the level of summer load waterline at the section within $0,4 \cdot (1 - C_b) \cdot L \leq 0,1L$ from the fore perpendicular;

$$f = \left\{ \frac{Lv_0}{430D_1\eta\phi} \left[\frac{2,5}{\phi^{0,3}} + 1,5 \left(\frac{L}{100} \right)^{2/3} \right] \right\}^{1,5} \left(\frac{L}{100} \right)^{0,75},$$

where: $D_1 = D + h_c$;

h_c – height of continuous hatch side coamings, in m (where these are not fitted $h_c = 0$);

$\Delta = 0,045(\alpha - 0,25)^2 \cdot [L/(20 \cdot D_1 \cdot \phi \cdot \eta)] \cdot (L/100)$;

η – refer to 1.1.4.3;

ϕ – determined from Table 1.4.4.3.

The above requirements apply to ships of restricted area of navigation, from 60 to 150 m in length.

Table 1.4.4.3

Area of navigation	φ
1	2
R1, A-R1	$1,1-0,23 L \cdot 10^{-2} \leq 1$
R2, A-R2	$1,0-0,25 L \cdot 10^{-2}$
R2-S**, R2-RS**, A-R2-S, A-R2-RS	$0,94-0,26 L \cdot 10^{-2}$
R2-S (4,5), R2-RS (4,5)	$0,92-0,29 L \cdot 10^{-2}$
R3-S, R3-RS, B-R3-S*, B-R3-RS*, C-R3-S, C-R3-RS	$0,71-0,22 L \cdot 10^{-2}$
R3, R3-IN, D-R3-S, D-R3-RS	$0,60-0,20 L \cdot 10^{-2}$

*,** refer to Table 1.3.1.5.

1.4.5 Bending moment due to wave impacts on the flare.

1.4.5.1 The bending moment due to wave impacts on the flare shall be calculated only for ships of length from 100 to 200 m where the relationship $A_F/(L \cdot z_F) \geq 0,1$ is satisfied.

A_F and z_F as determined from **1.4.2**.

1.4.5.2 The sagging bending moment due to wave impacts on the flare, M_F , shall be calculated as follows:

$$M_F = -k_F \cdot c_w \cdot B \cdot L^2 \cdot (C_b + 0,7) \cdot \alpha_F \cdot 10^{-3}, \quad (1.4.5.2)$$

where: $k_F = 7 \cdot (1 + 1,25 \cdot v_0/L) \cdot c_1 \cdot c_2$, but not more than 23;

$c_1 = (L - 100)/30$, for $100\text{m} \leq L < 130\text{m}$;

$c_1 = 1$, for $130\text{m} \leq L < 170\text{m}$;

$c_1 = 1 - (L - 170)/30$, for $170\text{m} \leq L \leq 200\text{m}$;

$c_2 = [5 \cdot A_F/(L \cdot z_F)] - 0,5$, at $0,1 \leq A_F/(L \cdot z_F) \leq 0,3$;

$c_2 = (A_F/L \cdot z_F) + 0,7$, at $0,3 < A_F/(L \cdot z_F) < 0,4$;

$c_2 = 1,1$, at $A_F/(L \cdot z_F) \geq 0,4$;

for c_w — refer to **1.3.1.4**;

v_0 — refer to **1.4.1.2.3**;

α_F — is obtained from Table 1.4.5.2 and Fig. 1.4.5.2.

Table 1.4.5.2

Position of section along the ship's length	α_F
$x/L \leq 0,15$	$0,667x/L$
$0,15 < x/L < 0,45$	$0,1 + 3(x/L - 0,15)$
$0,45 \leq x/L \leq 0,75$	1
$x/L > 0,75$	$1 - 4(x/L - 0,75)$

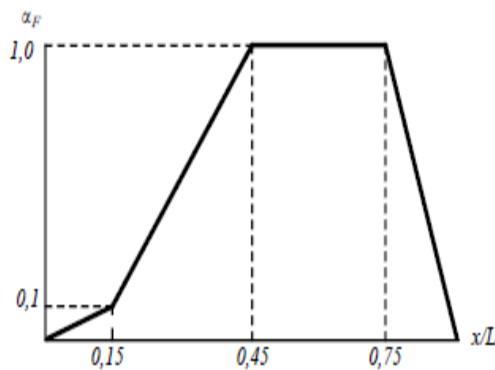

Fig.1.4.5.2

1.4.5.3 For ships of restricted area of navigation, the bending moment due to wave impacts on the flare M_F calculated in accordance with 1.4.5.2 shall be multiplied by the reduction factor φ determined from Table 1.4.4.3.

For ships of restricted areas of navigation **R3-S, R3-RS, B-R3-S and B-R3-RS** with restricted navigation at a wave height of 3% probability of not more than 3,5 m, **C-R3-S, C-R3-RS, R3, R3-IN, D-R3-S, D-R3-RS** $M_F=0$.

1.4.6 Hull section modulus and moment of inertia.

1.4.6.1 The requirements of this paragraph regulate the hull section modulus and moment of inertia about the horizontal neutral axis.

1.4.6.2 The hull section modulus (for deck and bottom) W , in cm^3 , at the section concerned shall not be less than

$$W = M_T \cdot 10^3 / \sigma, \quad (1.4.6.2)$$

where: $M_T = |M_{sw} + M_w|$ – design bending moment, in $\text{kN}\cdot\text{m}$, at the section concerned equal to the maximum absolute value of algebraic sum of M_{sw} and M_w components at this section;

M_{sw} – refer to 1.4.3, in $\text{kN}\cdot\text{m}$;

M_w – refer to 1.4.4;

$\sigma = 175 / \eta$, MPa.

1.4.6.3 In cases specified by 1.4.3.4, the section modulus W , determined in accordance with 1.4.6.2, shall be multiplied by the factor shall be multiplied by the factor m determined by the formula:

$$m = 1 + \frac{M_{sw}^{\min}}{10M_{sw}^{\max}} \left(\frac{M_{sw}^{\min} + M_{sw}^{\max}}{0,076c_w B L^2 (C_b + 0,7)} - 1 \right), \quad (1.4.6.3)$$

but not less than 1,

where: M_{sw}^{\min} , M_{sw}^{\max} – absolute values of hogging and sagging bending moments at the maximum range section, in kNm (refer to Fig. 1.4.3.4).

1.4.6.4 For ships for which the bending moment due to wave impacts on the flare (refer to 1.4.5) shall be considered the section modulus W , in cm^3 , at the section concerned shall not be less than:

$$W = \frac{M_T \cdot 10^{-3}}{\sigma}, \quad (1.4.6.4)$$

where: $M_T = |M_{sw} + M_w + M_F|$ – design bending moment, in $\text{kN}\cdot\text{m}$, at the section concerned equal to the maximum absolute value of algebraic sum of M_{sw} , M_w and M_F components at this section;

M_{sw} - maximum still water sagging bending moment or minimum hogging bending moment if solely the hogging bending moments occur at this hull section, in $\text{kN}\cdot\text{m}$;

M_w - wave sagging bending moment (refer to 1.4.4);

M_F - as determined from 1.4.5;

σ - refer to 1.4.6.2.

1.4.6.5 The hull section modulus determined from 1.4.6.2 ÷ 1.4.6.4 for maximum value of design bending moment shall be maintained within $0,4L$ amidships. However, if the maximum design bending moment occurs outside $0,4L$ amidships, the steady section modulus requirement is applicable over the ship's length up to the section where maximum design bending moment acts.

1.4.6.6 The hull section modulus shall be gradually reduced towards the ship's ends outside the region in which it is being maintained.

1.4.6.7 In any case, the hull section modulus, in cm^3 , within the midship region (for deck and bottom) shall not be less than

$$W_{\min} = c_w B L^2 (C_b + 0,7) \eta, \quad (1.4.6.7-1)$$

where: for c_w – refer to 1.3.1.4.

For ships of restricted area of navigation, the minimum hull section modulus, in cm^3 , within the midship

region (for deck and bottom) shall not be less than $W_{\min 1}$ or $W_{\min 2}$, whichever is the greater, determined by the following formulae:

$$W_{\min 1} = \varphi W_{\min}; \quad (1.4.6.7-2)$$

$$W_{\min 2} = 0,95\psi v\varphi W_{\min}, \quad (1.4.6.7-3)$$

where: φ – refer to Table 1.4.4.3;

ψ – refer to Formula (1.4.4.3-1);

v – refer to Formula (1.4.4.3-2).

1.4.6.8 Scantlings of all continuous longitudinal members of hull girder based on the section modulus requirement in **1.4.6.7** shall be maintained within $0,4L$ amidships. However, in special cases, based on consideration of type of ship, hull form and loading conditions, the scantlings may be gradually reduced towards the ends of the $0,4L$ part, bearing in mind the desire not to inhibit the ship's loading flexibility.

1.4.6.9 The moment of inertia of hull section I , in cm^4 , within the midship region shall not be less than:

$$I_{\min} = 3c_w B L^3 (C_b + 0,7), \quad (1.4.6.9-1)$$

where: c_w – as determined from **1.3.1.4**.

For ships of restricted area of navigation, I_{\min} shall be multiplied by the reduction factor j_0 determined by the formula:

$$\varphi_0 = 18\varphi\eta/(L/D)_{\max}, \quad (1.4.6.9-2)$$

where: for φ – refer to Table 1.4.4.3;

η – refer to **1.1.4.3**;

$(L/D)_{\max}$ – maximum permissible value of L/D for the area of navigation under consideration, obtained from Table 1.1.1.1.

1.4.6.10 As a minimum, hull longitudinal strength checks shall be carried out at the following locations outside amidships:

in way of the forward end of the engine room;

in way of the forward end of the foremost cargo hold;

where there are significant changes in the hull cross-section;

where there are changes in the framing system.

The following shall be made outside amidships: buckling strength of members contributing to the longitudinal strength and subjected to compressive and shear stresses shall be checked, in particular in regions where changes in the framing system or significant changes in the hull cross-section occur in compliance with **1.6.5**;

continuity of structure shall be maintained throughout the length of the ship. Where significant changes in structural arrangement occur adequate transitional structure shall be provided;

for ships with large deck openings such as a containerships, sections at $0,25L$ or near to the aft and forward quarter length positions shall be checked. For such ships with cargo holds aft of the superstructure, deckhouse or engine room, strength checks of sections in way of the aft end of the aft-most holds, and the aft end of the deckhouse or engine room shall be performed.

1.4.7 Thickness of side shell plating and continuous longitudinal bulkhead plating.

1.4.7.1 The thickness of side shell plating s , in mm, at the considered section over the length and depth of the ship where longitudinal bulkheads are not fitted shall not be less than:

$$s = S (N_{sw} + N_w) \cdot 10^2 / (2 \tau I), \quad (1.4.7.1)$$

where: N_{sw} – as defined in **1.4.3.2**, kN;

for N_w – refer to **1.4.4.2** and **1.4.4.3**;

$\tau = 110/\eta$, MPa.

1.4.7.2 The thickness of side shell plating s_s , s and thickness of longitudinal bulkhead plating s_l , in mm, at the section under consideration for ships with two plane longitudinal bulkheads shall not be less than:

$$s_s = S \alpha_s (N_{sw} + N_w) \cdot 10^2 / (\tau I); \quad (1.4.7.2-1)$$

$$s_l = S \alpha_l (N_{sw} + N_w) \cdot 10^2 / (\tau I); \quad (1.4.7.2-2)$$

where: for N_{sw} , N_w , τ – refer to 1.4.7.1;

$$\alpha_s = 0,27;$$

$$\alpha_l = 0,23.$$

1.4.7.3 For ships having one or more than two continuous plane longitudinal bulkheads as well as longitudinal bulkheads with horizontal corrugations the required thickness of side plating and members in question shall be calculated according to the procedure approved by the Register.

Appropriate calculation may also be required for ships with two continuous longitudinal bulkheads if the transverse distribution of load is substantially different from uniform distribution.

1.4.8 Calculation of actual hull section modulus.

1.4.8. The hull section modulus is determined:

for strength deck W_d^ϕ – at moulded deck line at side (lower edge of deck stringer);

for bottom W_b^ϕ – at moulded base line (top of plate keel).

For ships with continuous longitudinal strength members above strength deck including trunk and continuous hatch side coamings, W_b^ϕ is calculated by dividing the moment of inertia of hull section about the horizontal neutral axis by the value of z_T , determined by the formula:

$$z_T = z(0,9 + 0,2 y/B), \quad (1.4.8.1)$$

where: z – distance from neutral axis to the top of continuous strength member above deck included in the calculation of W_d^ϕ , in m;

y – horizontal distance from the centreline of the ship to the top of continuous strength member above deck included in the calculation of W_d^ϕ , in m.

z and y shall be measured to the point giving the largest value of z_T .

1.4.8.2 When calculating the hull section modulus, all continuous longitudinal strength members shall be taken into account, including continuous hatch side coamings, and, where the ship's design provides for multiple hatchways - the longitudinal deck strips between them on condition the deck strips are effectively supported by longitudinal bulkheads, including the topside tank bulkheads (inner skins).

The sectional area of long bridges or deckhouses shall be included with the reduction coefficient which similarly to stresses in the ship's hull and superstructure (deckhouse) is determined according to the procedure agreed with the Register.

Continuous hatch side coamings in ships with single hatches not above the mentioned structures may be included in the calculation of the hull section modulus only if the calculation has been specially approved to this effect.

The sectional area of longitudinal deck strips, each being of a uniform width throughout the length, including deck plating with longitudinal framing and hatch side coamings not supported by longitudinal bulkheads, is included with the reduction coefficient ζ , determined by the formula:

$$\zeta = m + \frac{0,65 + C_b}{3} \frac{L}{\Sigma l_H + \Delta l_1 + \Delta l_2}, \quad (1.4.8.2)$$

where:

$$m = \begin{cases} - 0,10 & \text{at } n = 1; \\ - 0,12 & \text{at } n = 2; \end{cases}$$

n – number of longitudinal strips over ship's breadth;

Σl_H – total length of longitudinal deck strips, in m;

$\Delta l_1, \Delta l_2$ – length of end attachments of longitudinal deck strips aft and forward, in m.

If the end of the longitudinal deck strip is effectively attached to continuous deck and/or longitudinal bulkhead (refer to Fig. 1.4.8.2):

$$\Delta l_{1,2} = 4f / B_{1,2} s_{d_{1,2}},$$

where: f – sectional area of one longitudinal deck strip, in cm²;

$B_{1,2}$ – breadth of ship in way of longitudinal deck strip termination, in m;

$s_{d_{1,2}}$ – average thickness of the portion of deck plating between the extension of longitudinal deck strip and ship's

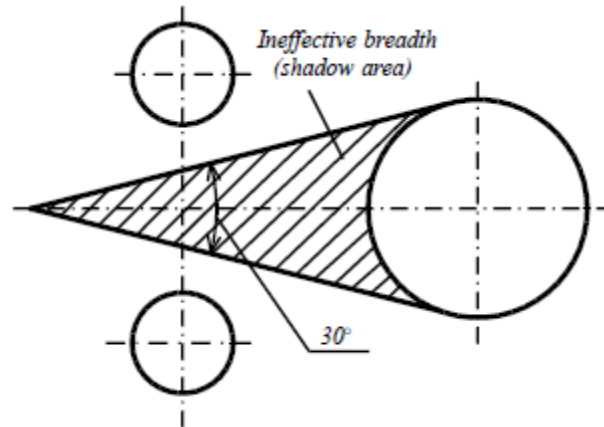

Fig.1.4.8.3. Design section.

1.4.8.4 Where continuous longitudinal members are built of higher tensile steel, they shall extend so far beyond amidships towards the ends as to provide a hull section modulus in way where the yield stress changes not less than required for an identical hull of ordinary steel.

1.4.8.5 The continuous longitudinal members at a distance from horizontal neutral axis of hull section greater than

$$\frac{z}{\eta} \frac{W_a}{W_{\eta=1}}, \quad (1.4.8.5)$$

where: z – distance of strength deck (upper face plate of continuous hatch side coaming) or bottom from neutral axis, in m;

η – factor given in Table 1.1.4.3 for the members of the remainder of hull section;

W_a , $W_{\eta=1}$ – actual section modulus and required section modulus with $\eta = 1$ for the deck (continuous hatch coaming or bottom respectively, shall be made of steel with the same yield stress as the strength deck (continuous hatch coaming).

1.4.9 Loading control facilities.

1.4.9.1 By loading control facilities are meant Loading Manual and loading instrument by means of which it can be ascertained that the still water bending moments, shear forces, and the still water torsional and lateral loads, where applicable, in any load or ballast condition will not exceed the specified permissible values.

1.4.9.2 Ships to be provided with loading control facilities are categorized as follows.

Category I:

ships with large deck opening, for which combined stresses due to vertical and horizontal hull girder bending, as well as torsional and lateral loads, shall be considered;

ships for which uneven loading, i.e. uneven distribution of cargo and/or ballast, is possible;

chemical tankers and gas carriers.

Category II:

ships with arrangement giving small possibilities for variation in cargo and ballast distribution;

ships on regular and fixed trading pattern where the Loading Manual gives sufficient guidance;

ships not falling under category **I** including ships of less than 120 m in length, which design takes uneven distribution of cargo or ballast into account.

1.4.9.3 Loading Manual is a document approved by the Register which describes:

the loading conditions on which the design of the ship has been based;

permissible limits of still water bending moment and shear force and, where applicable, limitations due to torsional and lateral loads;

the results of the calculations of still water bending moments, shear forces for loading conditions stated in **1.4.3.1**;

the allowable local loadings for the structure (hatch covers, decks, double bottom, etc.).

The Loading Manual shall be prepared in a language understood by the users and in English.

1.4.9.4 A loading instrument is an instrument approved by the Register, which is either analog or digital by means of which the still water bending moments, shear forces and torsional and lateral loads, where required, in any load or ballast condition can be easily and quickly checked at specified readout points.

The number and position of sections and permissible still water bending moments and shear forces as well as the limitations due to torsional and lateral loads shall be approved by the Register.

Single point loading instruments are not acceptable.

An approved Operational Manual shall be provided for the loading instrument.

The Operational Manual and calculation results shall be prepared in a language understood by the users and in English.

1.4.9.5 All ships other than category **II** ships of less 90 m in length, which deadweight is not greater than 30 % of summer load line displacement, shall be provided with the Loading Manual approved by the Register.

In addition to the Loading Manual, all ships of category **I** having length of 100 m and more shall carry a loading instrument approved by the Register (requirements for loading instruments are given in Appendix 2).

1.4.9.6 For ore carriers, ore-oil carriers and oil-bulk carriers having a length of 150 m and more, additional requirements for strength control during loading are given in **3.3.6**.

1.4.9.7 The stability and strength Booklet at carriage of non-grain bulk cargoes.

To prevent excessive hull stresses, provision shall be made for the Booklet as per SOLAS regulation VI/7.2 to be carried on board, including the following as a minimum:

.1 stability data required in **1.4.11**, Part IV "Stability";

.2 data on the capacity of ballast tanks and of equipment for their filling and emptying;

.3 maximum permissible load upon a unit of double-bottom plating surface;

.4 maximum permissible cargo hold load;

.5 general instructions concerning loading and unloading and pertinent to hull strength, including any limitations due to the worst operating conditions during loading, unloading, handling of water ballast, and during the voyage;

.6 any special limitations, for instance, those due to the worst operating conditions, where applicable;

.7 where necessary - strength calculations: maximum permissible forces and moments affecting the hull during loading, unloading and the voyage.

The Booklet shall be prepared in a language understood by the ship officers, and in English.

1.5 VIBRATION OF HULL STRUCTURES

1.5.1 General.

1.5.1.1 The present Chapter shall establish the highest permissible vibration levels (hereinafter, vibration standards) of hull structures in sea-going displacement ships.

1.5.1.2 The vibration standards are set down proceeding from the condition of ensuring the strength of hull structures and the dependability of machinery, instruments and equipment installed on board the ship.

1.5.1.3 The application of standards stipulated in this Chapter does not release one from compliance with sanitary norms and requirements of health Authorities and other requirements for permissible vibration parameters at work places in the accommodation, service and other spaces of ships.

1.5.1.4 Vibration standards for ship machinery and equipment are specified in Section 9, Part VII "Machinery Installations".

1.5.1.5 Regardless of vibrations measurements results in the first ship of a series and in single buildings vibration measurements to assess their vibration characteristics based on the standards of acceptable vibration parameters specified in **1.5.3** of this unit shall be carried out.

1.5.1.6 The procedure, scope and sequence of vibration measurement shall be approved by the Register.

1.5.2 Technical documentation.

After mooring tests and sea trials, a report on vibration measurement shall be submitted to the Register, which shall be approved by the management of the firm having carried out the evaluation of the vibration characteristics of the ship. Where additional measures are taken to reduce vibration, the report shall contain those measures as well as the results of a second measurement of vibrations to confirm the efficiency of measures taken.

1.5.3 Measured vibration parameters.

1.5.3.1 For the purpose of the present Chapter, the following vibration parameters have been adopted:

root mean square value of vibration velocity measured in one-third octave bands and, where necessary, in octave bands;

root mean square value of vibration acceleration and, in well-grounded cases, the root mean square or peak value of vibratory displacement.

1.5.3.2 Vibration parameters shall be measured in absolute units or in logarithmic units (decibels) with regard to standard threshold values of vibration velocity or acceleration equal to $5 \cdot 10^{-5}$ mm/s i $3 \cdot 10^{-4}$ m/s² accordingly.

1.5.3.3 Measurements shall be carried out in the following directions:

in each of the inter-perpendicular directions with regard to the ship: vertical, horizontal-transverse and horizontal-longitudinal direction, when measuring the main hull vibration;

in the direction normal to the plane of ship structures (deck, side, bulkheads, etc.) or in the lowest-rigidity direction of the hull girder, when measuring local vibration.

1.5.3.4 The permissible root mean square values of vibration velocity and vibration acceleration of the hull and superstructures as well as hull structures are mentioned in Table 1.5.3.4 and in Fig. 1.5.3.4.

Table 1.5.3.4

Mean geometric values of octave ranges, in Hz	Hull and superstructure, rigid members ¹				Hull structures							
					frames ²				plates			
	Permissible root mean square values											
	vibration velocity		vibration acceleration		vibration velocity		vibration acceleration		vibration velocity		vibration acceleration	
mm/s	dB	m/s ²	dB	mm/s	dB	m/s ²	dB	mm/s	dB	m/s ²	dB	
1,6	5,6	101	0,054	45	5,6	101	0,054	45	5,6	101	0,054	45
2	5,6	101	0,067	47	5,6	101	0,067	47	5,6	101	0,067	47
2,5	5,6	101	0,084	49	5,6	101	0,084	49	5,6	101	0,084	49
3,15	5,6	101	0,106	51	7,1	103	0,135	53	7,1	103	0,135	53
4	5,6	101	0,135	53	8,9	105	0,21	57	8,9	105	0,21	57
5	5,6	101	0,17	55	11	107	0,34	61	11	107	0,34	61
6,3	5,6	101	0,21	57	11	107	0,43	63	14	109	0,54	65
8	5,6	101	0,27	59	11	107	0,54	65	16	110	0,75	68
10	5,6	101	0,34	61	11	107	0,65	67	16	110	0,94	70
12,5	5,6	101	0,43	63	11	107	0,84	69	16	110	1,2	72
16	5,6	101	0,54	65	11	107	1,06	71	16	110	1,5	74
20	5,6	101	0,67	67	11	107	1,35	73	16	110	1,9	76
25	5,6	101	0,84	69	11	107	1,7	75	16	110	2,4	78

40	5,6	101	1,35	73	11	107	2,7	79	16	110	3,8	82
50	5,6	101	1,7	75	8,9	105	2,7	79	12,5	108	3,8	82
63	5,6	101	2,1	77	7,1	103	2,7	79	10	106	3,8	82
80	5,6	101	2,7	79	5,6	101	2,7	79	8	104	3,8	82

¹ Hull and superstructures, rigid members are the intersections of decks with main transverse and longitudinal bulkheads, sides, transom, superstructure walls, etc.

² Girders supporting the foundations of ship machinery and equipment are included.

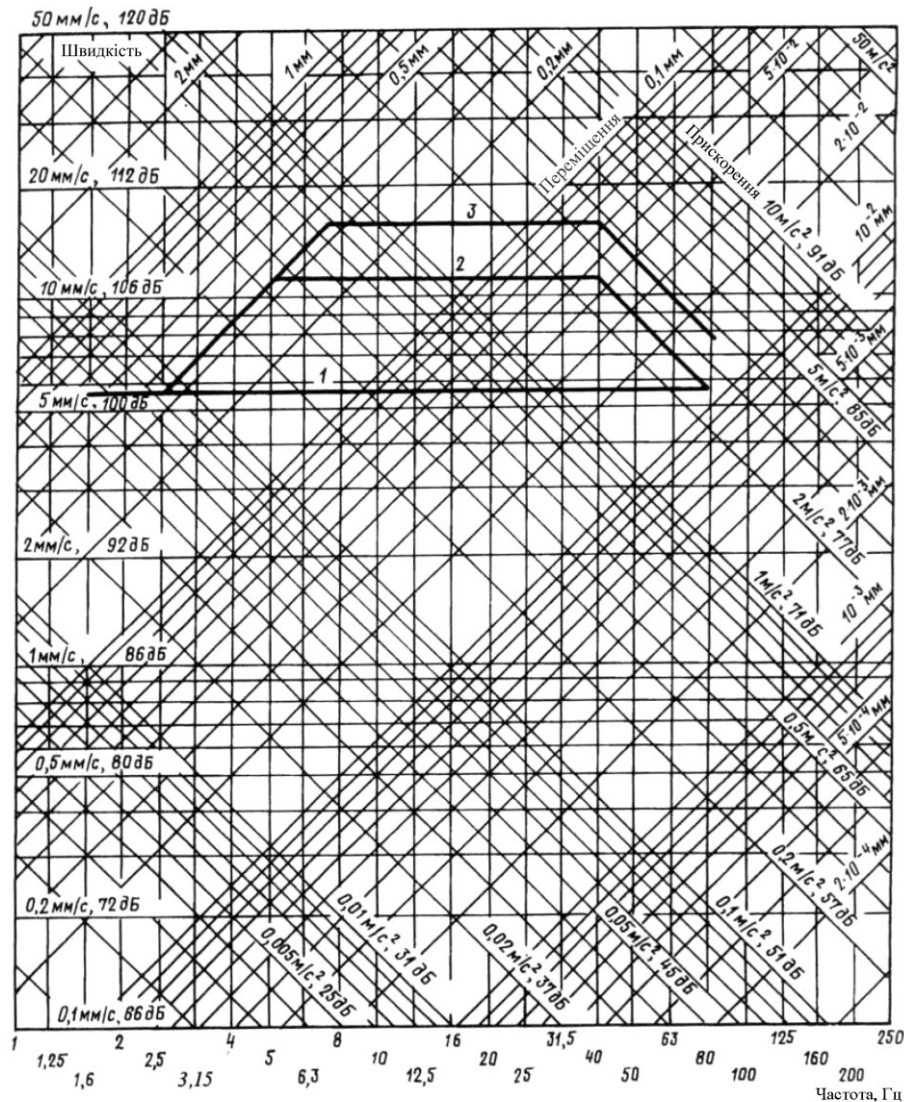

Fig.1.5.3.4. Permissible mean root values of vibration velocity and vibrational acceleration: 1 — hull, superstructures and rigid members; 2 — framing members including the girders by which the foundations of ship machinery and equipment are supported; 3 — plates.

1.5.3.5 When measuring the parameters in octave bands, the permissible values stated in Table 1.5.3.4 for mean geometric frequencies of 2, 4, 8, 16, 31,5 and 63 Гц, may be increased $1,41(\sqrt{2})$ times or by 3 dB as compared to tabulated values.

1.5.3.4 Permissible values given in Table 1.5.3.4 and in Fig. 1.5.3.4 shall not be exceeded at specified ship speeds and at zero speed, if specified.

1.6 REQUIREMENTS FOR SCANTLINGS OF HULL STRUCTURAL MEMBERS

1.6.1 General.

1.6.1.1 This Chapter contains general requirements for plating and framing.

1.6.1.2 Plate structure means a portion of plating bounded by stiffening members. By plate structures are meant portions of the deck, platform and inner bottom plating and portions of the bottom, side, bulkhead plating as well as webs of deep member.

1.6.1.3 In this Part the term "framing" includes primary members and deep members strengthening the plate structures. Deep members also serve as supporting structures for primary members. Primary members are deck longitudinals, side longitudinals, bulkhead longitudinals, inner bottom plating and bottom longitudinals, as well as vertical and horizontal stiffeners of bulkheads, frames, beams, reverse and bottom frames of bracket floors, etc. Deep members are deck transverses, deck girders, web frames, side stringers, floors, side girders, centre girder, vertical webs and horizontal girders of bulkheads, etc.

1.6.1.4 The scantlings of primary and deep members are based on the required section modulus, moment of inertia, web sectional area, thicknesses of web and face plate, as well as width of the face plate. Geometric properties of the member section, unless stated otherwise, are determined taking into account the effective flange. If the member is so arranged that it is not normal to the effective flange, the section modulus shall be increased in proportion to $1/\cos\alpha$ (where α – is the angle, in deg., between the member web and the perpendicular to the effective flange at the section considered). If $\alpha \leq 15^\circ$ no increase of section modulus is required.

1.6.1.5 Rounding off the required scantlings of structural members generally shall be made in the direction of increase. Plate thickness shall be rounded off to the nearest 0,5 or integer of millimetres.

The values of negative rolling tolerances for plates shall comply with the requirements of **3.2.8**, Part XIII "Materials".

1.6.2 Symbols.

z_i – vertical distance from horizontal neutral axis of ship to the centre of section area of the longitudinal considered, in m;

i – actual moment of inertia of the longitudinal taking into account the effective flange, in cm^4 ;

I – actual moment of inertia of the hull about the horizontal neutral axis, in cm^4 ;

W – section modulus of the member taking into account the effective flange, cm^3 ;

f – actual section of the member without the effective flange, in cm^2 ;

f_c – section of the member rib taking into account openings, net, cm^2 ;

h – depth of the member web, in cm;

l – span of concerned member, determined from **1.6.3.1**, in m;

a – spacing, in m, of concerned primary or deep members of longitudinal or transverse framing system; where this varies, a is a half-sum of distances of adjacent members from the member concerned;

a_f – primary member effective flange width, in m;

c_f – deep member effective flange breadth, in m;

p – design pressure at the point of load application, determined in the relevant Chapters of this Part, in kPa.

σ_n – design specified yield stress for normal stresses, in MPa, determined from **1.1.4.3**;

τ_n – design specified yield stress for shear stresses, in MPa, determined from **1.1.4.3**;

Δs – corrosion allowance, in mm, determined from **1.1.5.1**.

1.6.3 Span and effective flange of member.

1.6.3.1 The span of primary and deep member l is measured along the member face plate as the distance between its span points.

Unless provided otherwise, where the end brackets are fitted, the span points shall be taken at the mid-length of the bracket. In this case, the span point position shall be such that the height of the end bracket in it does not exceed the web depth of the member considered (refer to Fig. **1.6.3.1**).

For curvilinear members the span shall be taken equal to the chord connecting the span point centres.

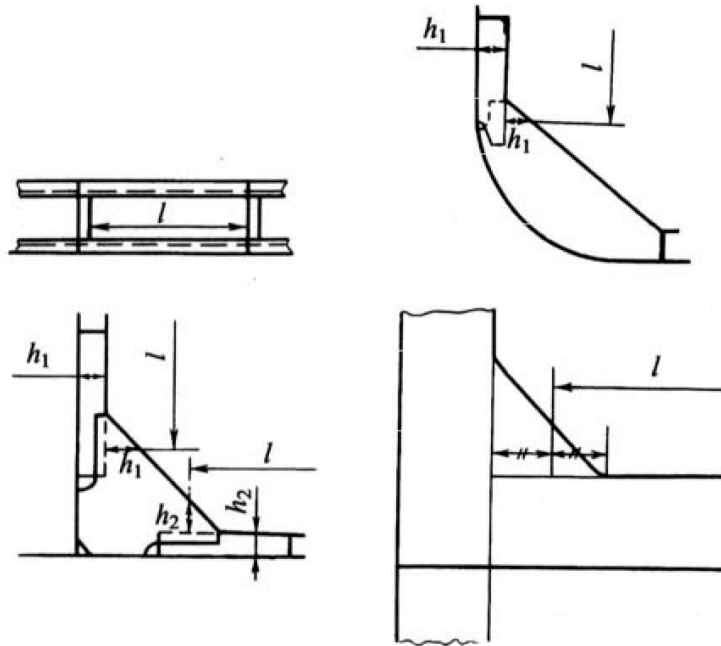

Fig. 1.6.3.1

1.6.3.2 The thickness of the effective flange is taken equal to its mean thickness in the considered section of the member.

1.6.3.3 The width of the effective flange a_f , in m, of primary members shall be determined by the formulae:

$$a_f = l / 6; \quad (1.6.3.3-1)$$

$$a_f = 0,5(a_1 + a_2), \quad (1.6.3.3-2)$$

where a_1, a_2 – distance of the considered member from the nearest members of the same direction located on both sides of the considered member, in m.

1.6.3.4 The width of the effective flange of deep members c_f , in m, is determined by the formula:

$$c_f = k c, \quad (1.6.3.4)$$

where: $c = 0,5(c_1 + c_2)$;

c_1, c_2 – distance of the considered deep member from the nearest deep members of the same direction located on both sides of the considered member, in m;

k – factor obtained from Table 1.6.3.4 depending on c , given span l_{sp} and number n of members supported by considered deep members.

For simply supported deep members the given span $l_{sp} = l$, and for fixed deep members $l_{sp} = 0,6l$.

For intermediate values l_{sp}/c and n factor k is determined by linear interpolation.

The way in which the framing members shall be supported (simple supporting or fixing) is determined proceeding from the general engineering principles with regard for the actual structure (presence of brackets, welding of webs, face plates, etc.) and is characterized by the presence or absence of bending moment effects in the span point of the member.

Table 1.6.3.4

Number of members n	k values at l_{sp}/c						
	1	2	3	4	5	6	7 and more
≥ 6	0,38	0,62	0,79	0,88	0,94	0,98	1
≤ 3	0,21	0,4	0,53	0,64	0,72	0,78	0,8

1.6.3.5 The width of the hatch coaming effective flange shall be equal to one-twelfth of their span but not more than half the distance between the cargo hatch and the ship's side for the side coaming and, accordingly, half the distance between a cargo hatch and a transverse bulkhead (or the beam nearest to the cargo hatch) for the hatch end coaming.

1.6.3.6 The width of the effective flange of deep members located normal to the direction of corrugations shall be taken equal to $15s$ and $20s$ for trapezoidal and wave-shaped corrugations respectively (s = thickness of corrugated plates, in mm) or $0,1c$ (for c , refer to 1.6.3.4), in mm, whichever is less.

1.6.3.7 Where primary members parallel to deep members are fitted over the width of the effective flange of the latter, full cross-sectional areas of the above primary members shall be adopted for calculation when determining the inertia moment and section modulus of the deep members.

1.6.4 Scantlings of structural members.

1.6.4.1 The section modulus W , in cm^3 and moment of inertia i , in cm^4 , of primary members of rolled section shall not be less than:

$$\begin{aligned} W &= W' \omega_k, \\ i &= i' j_k; \end{aligned} \quad (1.6.4.1-1)$$

for built-up welded members

$$\begin{aligned} W &= W' + \Delta W, \\ i &= i' + \Delta i, \end{aligned} \quad (1.6.4.1-2)$$

where W' – section modulus of member considered, in cm^3 , in the middle of service life, determined from **1.6.4.2**;

i' – moment of inertia of the member considered, in cm^4 in the middle of service life, determined in the relevant sections of these Rules;

ω_k, j_k – multipliers taking into account corrosion allowance, determined in accordance with **1.1.5.3**;

$\Delta W, \Delta i$ – part of the section modulus and moment of inertia, which is determined by subsequent increase in thickness of profile elements by the value Δs .

1.6.4.2 The section modulus of member considered, in cm^3 , without taking into account corrosion allowance is determined by the formula:

$$W' = Ql \cdot 10^3 / (m k_\sigma \sigma_n), \quad (1.6.4.2)$$

where $Q = pal$ – transverse load on member considered, in kN;

m, k_σ – factors of bending moment and permissible stresses to be found in the relevant Chapters of this Part;

σ_n – estimated normative yield stress at normal stresses, in MPa, determined from **1.1.4.3**.

1.6.4.3 The net sectional area (excluding openings) f_w , cm^2 , of primary and deep member webs shall not be less than:

.1 for members of rolled section

$$f_c = \frac{10N_{\max}}{k_\tau \tau_n} \omega_k, \quad (1.6.4.3-1)$$

.2 for built-up welded members

$$f_c = \frac{10N_{\max}}{k_\tau \tau_n} + 0,1h\Delta s, \quad (1.6.4.3-2)$$

where N_{\max}, k_τ – maximum shear force value and permissible shear stress factor as defined in the relevant Chapters of this Part;

h – general height of the member profile, in cm;

ω_k – refer to **1.1.5.3**;

τ_n – refer to **1.1.4.3**;

Δs – refer to **1.1.5.1**.

1.6.4.4 The thickness s , in mm, of the plates under transverse load shall not be less than

$$s = mak \sqrt{\frac{p}{k_{\sigma} \sigma_n}} + \Delta s, \quad (1.6.4.4)$$

where: m, k_{σ} – bending moment and permissible stress factors as defined in the relevant chapters of this Part;
 $k = 1,2 - 0,5 \cdot a/a_1$, but not greater than 1;

a, a_1 – smaller and greater sizes, in m, of supporting contour sides of plate structure;

Δs – corrosion allowance, in mm, determined from **1.1.5.1**.

1.6.4.5 The scantlings of the corrugated structures shall comply with the following requirements:

.1 the thickness of the trapezoidal corrugations shall be determined by Formula (1.6.4.4), taken a equal to b or c , whichever is the greater (refer to Fig. 1.6.4.5.1).

The following relationship shall be satisfied

$$b/s \leq 0,06\sqrt{\eta} \quad (1.6.4.5.1)$$

where β_0 – half-angle of spread of corrugation (refer to Fig. 1.6.4.5.1);

s – thickness, mm, (Fig. 1.6.4.5.1).

Angle φ (refer to Fig. 1.6.4.5.1, a) shall be assumed not less than 40° .

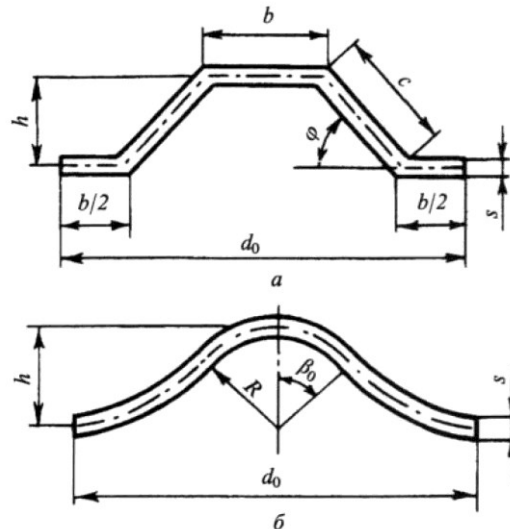

Fig. 1.6.4.5.1

.2 the thickness of the wave-shaped corrugations s , in mm, shall not be less than:

$$s = 22\beta_0 R \sqrt{\frac{p}{k_{\sigma} \sigma_n}} + \Delta s, \quad (1.6.4.5.2-1)$$

where: β_0 – half-angle of spread of corrugation (refer to Fig. 1.6.4.5.1, b), in rad;

R – radius of corrugation, in m;

k_{σ} – radius of corrugation, in m determined in the relevant Chapters of this Part;

σ_n – estimated normative yield stress at normal stresses, in MPa, determined from **1.1.4.3**;

Δs – corrosion allowance, in mm, determined from **1.1.5.1**.

In this case, the following relationship shall be satisfied:

$$R/s \leq 17/R_{eH}. \quad (1.6.4.5.2-2)$$

where: R_{eH} – upper yield stress, in MPa;

s – thickness, mm, (refer to Fig. 1.6.4.5.1).

.3 the section modulus of the corrugation is determined according to **1.6.4.1**:

$Q = pd_0 l$, (d_0 – refer to Fig.1.6.4.5.1).

The spacing and section modulus of corrugations can be determined by the formulae given in Table 1.6.4.5.3. (Linear dimensions are expressed in cm, φ , β_0 – in deg.).

Factor γ is determined by the formula:

$$\gamma = 2 \frac{\beta_0 + 2\beta_0 \cos^2 \beta_0 - 1,5 \sin 2\beta_0}{1 - \cos \beta_0} \quad (1.6.4.5.3)$$

In calculating the factor γ , the angle β_0 shall be taken in rad.

Table 1.6.4.5.3

Type of corrugation	Spacing of corrugations	Section modulus
Trapezoidal	$d_0 = 2(b + c \cos \varphi)$	$W = hs(b + c / 3)$
Wave-shaped	$d_0 = 4R \sin \beta_0$	$W = \gamma s R^2$

1.6.4.6 Permissible stress factors k_σ and k_τ , defined in the relevant chapters of this Part may be increased for ships of restricted areas of navigation:

R2, A-R2, R2-S, R2-RS, A-R2-S, A-R2-RS, B-R3-S and **B-R3-RS** with restriction of navigation at a wave height of 3% probability of 4,5m or more, by 5 %;

R3-S, R3-RS, B-R3-S and **B-R3-RS** with restriction of navigation at a wave height of 3% probability of 4,5m or less, **C-R3-S, C-R3-RS, R3, R3-IN, D-R3-S, D-R3-RS** by 10%,

unless dependent upon the factors k_B and k_D determined by Formula (2.2.4.1).

1.6.5 Buckling strength of hull structural members.

1.6.5.1 The buckling strength of longitudinals, shell plates and hull structure plating shall be ensured in ships of unrestricted service, including sign **A**, and ships of restricted areas of navigation **R1, A-R1** and **R2, A-R2** 65 m and greater in length, of restricted areas of navigation **R2-S, R2-RS, A-R2-S, A-R2-RS, B-R3-S, B-R3-RS, C-R3-S, C-R3-RS, R3-S, R3-RS, R3, R3-IN, D-R3-S, D-R3-RS** 60 m and greater in length subject to compressive stresses due to longitudinal bending of the hull girder.

Effective compressive stresses σ_c , in MPa, shall be determined by the following formul:

$$\sigma_c = M_T z_i \cdot 10^5 / I \geq 30 / \eta, \quad (1.6.5.1-1)$$

where M_T – design bending moment, in kN·m, at the section under consideration equal to the maximum absolute value of algebraic sum of the moment components; $M_T = |M_{sw} + M_w|$ - for longitudinal members arranged below the neutral axis;

$M_T = |M_{sw} + M_w + M_F|$ - for longitudinal members arranged above the neutral axis;

M_{sw} – as defined in 1.4.3, in kN·m;

M_w – as determined from 1.4.4, in kN·m.

M_F – refer to 1.4.5, in kN·m.

The maximum hogging bending moment shall be assumed as design value M_T for longitudinal members arranged below the neutral axis, and the maximum sagging bending moment — for longitudinal members arranged above the neutral axis.

The buckling strength of side shell and longitudinal bulkheads at the section considered shall be ensured under shear stresses τ_c , in MPa, calculated by the following formulae:

for side shell plating in ships without effective longitudinal bulkheads

$$\tau_c = \frac{N_{sw} + N_w}{2s} \frac{S}{I} \cdot 10^2, \quad (1.6.5.1-2)$$

for side shell plating in ships with two effective longitudinal bulkheads

$$\tau_c = \frac{N_{sw} + N_w}{s_s} \frac{S}{I} \alpha_s \cdot 10^2, \quad (1.6.5.1-3)$$

for longitudinal bulkhead plating in ships with two effective longitudinal bulkheads

$$\tau_c = \frac{N_{sw} + N_w}{s_l} \frac{S}{I} \alpha_l \cdot 10^2, \quad (1.6.5.1-4)$$

where N_{sw} – still water shear force at the section considered, defined in 1.4.3, in kN;

N_w – wave vertical shear force determined from 1.4.4.2;

s – actual thickness of side shell plating in ships without longitudinal bulkheads, in mm;

s_s, s_l – actual thicknesses of side shell plating and longitudinal bulkhead plating at the section considered in ships with two longitudinal bulkheads, in mm;

S, I – as defined in 1.4.2;

for α_s, α_l – refer to 1.4.7.2.

Where one or more than two continuous longitudinal plane bulkheads or longitudinal bulkheads with horizontal corrugations are fitted, the shear stresses are determined by a procedure approved by the Register.

1.6.5.2 The buckling strength of longitudinal members is considered sufficient if the following conditions are met:

$$k \sigma_c \leq \sigma_{cr}; \quad \tau_c \leq \tau_{cr}, \quad (1.6.5.2-1)$$

where $k = 1,0$ – for plating and for web plating of stiffeners;

$k = 1,1$ – for stiffeners;

for σ_c i τ_c – refer to 1.6.5.1;

for σ_{cr} i τ_{cr} – refer to 1.6.5.3.

For plate panels, the factor k may be reduced in respect of ships of restricted navigation areas:

R1, A-R1 – by 10%;

R2, A-R2, R2-S, R2-RS, A-R2-S, A-R2-RS (refer to 1.6.4.6) – by 15%;

B-R3-S, B-R3-RS (refer to 1.6.4.6), **C-R3-S, C-R3-RS, R3-S, R3-RS, R3, R3-IN, D-R3-S, D-R3-RS** and for berth-connected ships – by 20%.

In this case, when determining the actual section modulus of hull in accordance with 1.4.8 the strength reduction of compressed plate shall be considered, i.e. where $\sigma_{cr} < \sigma_c$ the plates shall be included in the hull girder section, except for the areas adjoining the longitudinals and having a breadth equal to 0,25 of the shorter side of supporting contour, with the reduced factor ψ_n , to be determined by the formula:

$$\psi_n = \sigma_{cr} / \sigma_c. \quad (1.6.5.2-2)$$

1.6.5.3 Critical stresses σ_{cr} and τ_{cr} , in MPa, shall be determined by the formulae:

$$\begin{aligned} \sigma_{cr} &= \sigma_e \quad \text{when} \quad \sigma_e \leq 0,5 R_{eH}; \\ \sigma_{cr} &= R_{eH} (1,00 - R_{eH}/4\sigma_e) \quad \text{when} \quad \sigma_e > 0,5 R_{eH}; \\ \tau_{cr} &= \tau_e \quad \text{when} \quad \tau_e \leq 0,29 R_{eH}; \\ \tau_{cr} &= R_{eH} (0,58 - 0,08 R_{eH}/\tau_e) \quad \text{when} \quad \tau_e > 0,29 R_{eH}, \end{aligned}$$

where σ_e and τ_e – Euler normal and shear stresses to be determined in accordance with 1.6.5.4 and 1.6.5.5.

1.6.5.4 When checking the buckling strength, the Euler stresses σ_e , in MPa, for primary and deep longitudinal members shall be determined by the following formulae:

.1 for column buckling of primary longitudinal members without rotation of the cross section,

$$\sigma_e = 206 i / f l^2, \quad (1.6.5.4.1)$$

where i – moment of inertia, in cm^4 , of longitudinal, including plate flange and calculated with thickness reduced by the value of Δs (for Δs – refer to Table 1.6.5.5-2);

f – cross-sectional area, in cm^2 , of longitudinal, including plate flange and calculated with a thickness reduced by the value of Δs (for Δs refer to Table 1.6.5.5-2); a plate flange equal to the frame spacing may be included;

.2 for torsional buckling of primary longitudinal members

$$\sigma_e = (203/l^2)(i_w/i_p)(m^2+k/m^2)+79310 i_l/i_p, \quad (1.6.5.4.2)$$

where: $k = 0,05 c l^4 / i_w$;

m – number of half waves, given by Table 1.6.5.4.2;

Table 1.6.5.4.2

k	$0 < k < 4$	$4 < k < 36$	$36 < k < 144$	$(m-1)^2 m^2 < k < m^2(m+1)^2$
m	1	2	3	m

i_t – moment of inertia, in cm^4 , of profile under simple torsion (without plate flange), determined as follows:

$i_t = h_c s_c^3 / 30000$ – for flat bars;

$i_t = [h_c s_c^3 + b_n s_n^3 (1 - 0,63 s_n / b_n)] / 30000$ – for angles, bulb, symmetrical bulb and T-profiles;

i_p – polar moment of inertia, in cm^4 , of profile about connection of stiffener to plate, determined as follows:

$i_p = h_c^3 s_c / 30000 - 4$ for flat bars;

$i_p = (h_c^3 s_c + 3 h_c^2 b_n s_n) / 30000$ – for angles, bulb, symmetrical bulb and T-profiles;

i_w – sectional moment of inertia, in cm^6 , of profile about connection of stiffener to plate, determined as follows:

$i_w = h_c^3 s_c^3 \cdot 10^{-6} / 36$ – for flat bars;

$i_w = s_n b_n^3 h_c^2 \cdot 10^{-6} / 12$ – for T- and symmetrical bulb profiles;

$i_w = \frac{b_n^3 h_c^2}{12(b_n + h_c)^2} [s_n (b_n^2 + 2b_n h_c + 4h_c^2) + 3s_c b_n h_c] \cdot 10^{-6}$ – for angles and bulb profiles;

h_c – web height, in mm;

s_c – web thickness, in mm, reduced by the value of Δs (for Δs – refer to Table 1.6.5.5-2);

b_f – flange width, in mm, for angles and T-profiles or bulb width, in mm, for bulb and symmetrical bulb profiles;

s_f – flange thickness or bulb thickness, in mm, reduced by the value of Δs for Δs – refer to Table 1.6.5.5-2). For bulb and symmetrical bulb profiles, s_f may be adopted equal to the mean thickness of the bulb;

c – spring stiffness exerted by supporting plate panel, determined by the formula:

$$c = \frac{68,7 k_p s^3}{\left(1 + \frac{1,33 k_p h_c s^3}{a s_c^3} \cdot 10^{-3}\right) a} ;$$

$k_p = 1 - \sigma_c / \sigma_e \geq 0$ (to be taken not less than 0,1 for angles, bulb, symmetrical bulb and T-profiles);

σ_c – compressive stress according to 1.6.5.1;

σ_e – Euler stress of supporting plate according to 1.6.5.5;

s – supporting plate thickness, in mm, reduced by the value of Δs for Δs – refer to Table 1.6.5.5-2);

a – distance between longitudinals.

.3 for web and flange buckling:

$$\sigma_e = 7,83 (s_f / h_c)^2 \cdot 10^5; \quad (1.6.5.4.3)$$

for flanges of deep longitudinal members buckling is taken care by the following requirement

$$b_n / s_n \geq 15 ,$$

where b_f – flange width, in mm, for angles, half the flange width for T-sections;

s_f – flange thickness, in mm.

1.6.5.5 Euler normal σ_e and shear τ_e stresses, in MPa, for plate structures shall be determined as for rectangular plates by the formulae:

$$\sigma_e = 0,1854 n (s' / b)^2; \quad (1.6.5.5-1)$$

$$\tau_e = 0,1854 n (s' / b)^2, \quad (1.6.5.5-2)$$

where n factor depending on the load type of the plate and the ratio of sides (Table 1.6.5.5-1);

s' – as-built thickness of the plate reduced by the value of Δs , obtained from Table 1.6.5.5-2;

b – plate side located normal to the direction of normal compressive stresses; when the plate is exposed to shear stresses, b is the smaller side of the plate, in m.

Table 1.6.5.5-1

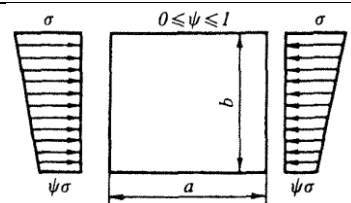
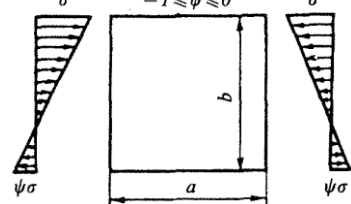
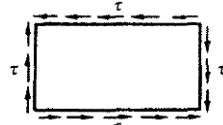
Type of load	$\gamma = a/b$	n
	$\gamma > 1$	$\frac{8,4}{\psi + 1,1}$
	$\gamma \leq 1$	$\varepsilon \left(\gamma + \frac{1}{\gamma} \right)^2 \frac{2,1}{\psi + 1,1}$
	$\gamma > 1$	$10 \psi^2 - 6,4 \psi + 7,6$
	$\gamma \leq 1$	$\varepsilon \left[10 \psi^2 - 14 \psi + 1,9 (1 + \psi) (\gamma + 1/\gamma)^2 \right]$
	$\gamma > 1$	$5,34 + 4 / \gamma^2$

Notes:

- ψ – ratio between smallest and largest compressive stress when linear variation across panel;
- $\varepsilon = 1,3$ – when plating is stiffened by floors or deep girders;
1,21 – when stiffeners are angles, symmetrical bulbs or T-sections;
1,1 – when stiffeners are bulb flats;
1,05 – when stiffeners are flat bars.

Table 1.6.5.5-2

Structure	Δs , in mm
Compartments carrying dry bulk cargoes. Vertical surfaces and surfaces sloped at an angle greater than 258 to the horizontal line. One side exposure to ballast and/or liquid cargo	0,05 s (0,5 ≤ Δs ≤ 1)
Horizontal surfaces and surfaces sloped at an angle less than 258 to the horizontal line. One side exposure to ballast and/or liquid cargo	0,10 s (2 ≤ Δs ≤ 3)
Vertical surfaces and surfaces sloped at an angle greater than 258 to the horizontal line. Two side exposure to ballast and/or liquid cargo	0,15 s (2 ≤ Δs ≤ 4)
Horizontal surfaces and surfaces sloped at an angle less than 258 to the horizontal line. Two side exposure to ballast and/or liquid cargo	0,15 s (2 ≤ Δs ≤ 4)
otherwise	$\Delta s = 0$

where: s – as-built thickness, in mm, of the structural member under consideration.

1.6.5.6 The moment of inertia i , in cm^4 , of the stiffeners on deep girder webs (refer to 1.7.3.2) shall not be less than determined by the formulae:

for the stiffeners fitted normal to the girder face plate

$$i = \gamma a s^3 \cdot 10^{-3}; \quad (1.6.5.6-1)$$

for the stiffeners parallel to the girder face plate

$$i = 2,35(f + 0,1 a s)^2 / \eta, \quad (1.6.5.6-2)$$

where γ – coefficient obtained from Table 1.6.5.6 depending on the ratio of the girder web depth h to the spacing of stiffeners a ;

- a – spacing of stiffeners, in cm;
- s – actual thickness of the web, in mm;
- f – actual cross-sectional area of the stiffener, in cm²;
- l – span of the stiffener, in m;
- η – as determined according to 1.1.4.3.

Table 1.6.5.6

h/a_1	1 and less	1,2	1,4	1,6	1,8	2,0	2,5	3,0	3,5	4,0
γ	0,3	0,6	1,3	2,0	2,9	4,1	8,0	12,4	16,8	21,2

Note: The intermediate values of γ are determined by linear interpolation.

1.6.6 Aluminium alloy structures.

1.6.6.1 The scantlings of aluminium alloy structures shall be determined by conversion of the scantlings relating to the corresponding steel structures.

The conversion shall be made using the formulae of Table 1.6.6.1 without considering the limits by minimum scantlings of steel structures.

Table 1.6.6.1

Parameter	Requirement
Thickness of plating for the shell, decks (without covering), bulkheads, enclosures and other details made of plates	$s_1 = s \sqrt{R_{eH} / R_{p0,2}}$ – for superstructures; $s_1 = 0,9s \sqrt{R_{eH} / R_{p0,2}}$ – for main hull
Section modulus of framing members	$W_1 = W \cdot R_{eH} / R_{p0,2}$
Cross-sectional area of pillars	$f_1 = f \cdot R_{eH} / R_{p0,2}$
Moment of inertia of pillars and framing members	$I_1 = 3I$

Note. $R_{p0,2}$ – proof stress of aluminium alloy, in MPa.

The values of s, W, f, I , as stipulated by the Rules may be adopted without corrosion allowance.

1.6.6.2 The sectional area of sternframe, stem, bar keel and propeller shaft brackets shall be 1,3 times that required for steel application.

1.6.6.3 Where continuous welds (fillets, butt welds) are located in most stressed positions, account shall be taken of the reduction in strength at the welded joint location depending on the given aluminium alloy and the process of welding.

1.6.6.4 The bimetallic (steel — aluminium) pressed elements for connection of steel and aluminium alloy structures may be used based on appropriate technical background.

1.7 WELDED STRUCTURES AND JOINTS

1.7.1 General.

1.7.1.1 Any change in the shape or section of the members of welded hull structure shall take place gradually. All openings shall have rounded corners and smooth edges.

1.7.1.2 The scantlings of sections and the thicknesses of plates used for longitudinal members shall change gradually throughout the ship's length.

Any change of framing system and plating thicknesses used for the strength deck, bottom, side shell and longitudinal bulkheads shall not be permitted in areas where mechanical properties of steel change.

1.7.1.3 Continuity shall be ensured for as many of main longitudinal members as possible, and a gradual change of their sections is required in way of the ends together with other arrangements, contributing to the reduction of stress concentration.

1.7.1.4 In tight structures, as well as in non-tight structures subject to intense vibration, stiffeners and similar details shall be fitted to prevent hard spots in the plating at the toes of brackets and in way of face plates of the members passing through, or terminating at the above-mentioned structures.

1.7.1.5 The length of unsupported plating between the end of a longitudinal and the nearest web normal

to direction member shall be as short as possible, however, not more than $4s$ or 60 mm, whichever is less (s = plate thickness, in mm).

1.7.1.6 For the purpose of this Part, the hull structures subject to intense vibration are those situated in way of machinery and equipment which constitute a source of vibration.

Considered as regions with high level of vibration in all ships are the regions situated below the lower platform continuous within the engine room and bounded:

at aft end, by a section forward of the edge of propeller boss at twice the propeller diameter, but not less than to the after peak bulkhead;

in the engine room, by the bulkheads of this space.

The bulkheads forming boundaries of engine room, the after peak bulkhead and the lower continuous platform in the above regions throughout the length of the ship are considered to be structures subject to intense vibration.

1.7.1.7 In way of the ends of bulwark, bilge keels, and other details welded to the hull, as well as generally of gutterway bars, their height shall decrease on a length of at least 1,5 times the height of these members. The ends of bulwarks shall be tapered. This is also recommended for the portions of the ends of the gutter bars.

1.7.1.8 Welded joints, welding consumables and procedures, testing and inspection methods of welded joints shall comply with requirements of Part XIV "Welding".

1.7.2 Connections of framing members.

1.7.2.1 The framing members shall have butt-welded joints, brackets shall be fitted in line with the members connected. Overlapping joints may be permitted, except for in regions with high level of vibration, deep member connections and in way of heavy concentrated loads.

Overlapping brackets may be fitted in line with the members connected in regions where the bending moment in the span point is less than the bending moment in span of the member, for example, in upper section of frames and vertical stiffeners of bulkheads.

Brackets shall be made of material having generally the same yield strength as the connections of framing members.

1.7.2.2 Connections of primary members.

1.7.2.2.1 Unless provided otherwise, the size of brackets c , in cm, measured in accordance with Fig. 1.7.2.2.1 shall be determined by the formula:

$$c = 5 \cdot \sqrt{W/s}, \quad (1.7.2.2.1)$$

where: W – required section modulus of the member attached, in cm^3 ;
 s – thickness of bracket, in mm.

The thickness of bracket is taken equal to that of the member web.

Where the web thickness is more than 7 mm the bracket thickness may be reduced by 1 mm;

where the web thickness is more than 12 mm, the bracket thickness may be reduced by 2 mm.

Where a bracket connects two members of different profile, the characteristics of the smaller profile shall be used for determining the bracket size.

The bracket height h (refer to Fig. 1.7.2.2.1) shall be not less than 0,7 times the required size c .

The size of brackets determined as indicated above, refers to the case when the members to be interconnected are not welded to each other or the member butts are not welded to the plating. The allowable gap shall not exceed 40 mm or 25 % of size c , whichever is less. Otherwise, c may be required to be increased.

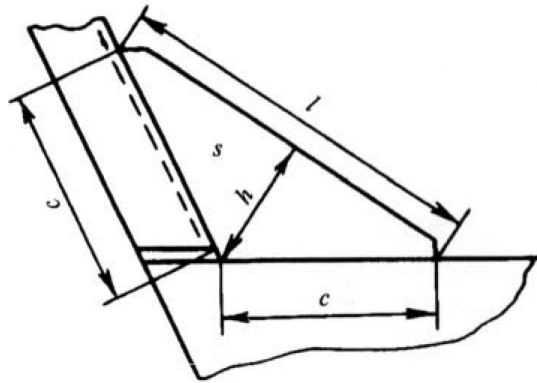

Fig. 1.7.2.2.1

1.7.2.2.2 If the free edge l in mm, of a bracket (refer to Fig. 1.7.2.2.1) is longer than $45s$ (s – thickness of the bracket, in mm) the bracket shall have a flange (face plate).

The width of the flange shall be not less than 50 mm, the width of the face plate, not less than 75 mm. The thickness of the face plate shall not be less than that of the bracket. The width of the flange (face plate) shall be in accordance with the requirements of **1.7.3.1**.

1.7.2.2.3 The size of brackets may be reduced:

by 10 per cent, where the framing members are welded to each other or to the plating;

by 15 per cent, where a face plate or flange is provided;

by 25 per cent, where the framing members are welded to each other and the brackets are provided with a face plate or flange.

1.7.2.2.4 In regions with high level of vibration the butt ends of framing members shall generally be connected, with the minimum dimensions of the plating portions unsupported by the framing (refer to Fig. 1.7.2.2.4).

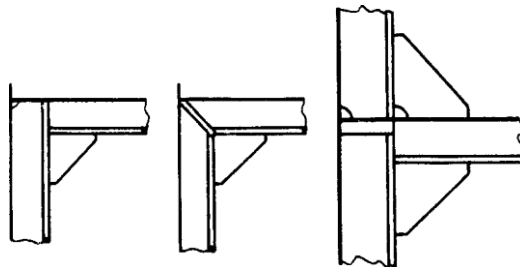

Fig. 1.7.2.2.4

1.7.2.2.5 Where there is a gap between the butt of beam and the frame in way of side strengthening of ships mooring at sea, in region **I** of ships of ice classes **Ice6**, **Ice5**, **Ice4**, in areas between *USWL* and *LSWL* ships of polar classes **PC1** ÷ **PC6**, ships of Baltic ice classes **IA Super** – **IB**, and in region **AI** of ships of ice class **Ice3** ice strengthening and in areas **B** and **BI** polar class ships **PC7**, and in bow area of Baltic ice class ships **IC**, the beam bracket shall have a face plate or flange.

1.7.2.3 Deep members are recommended to be connected by rounded brackets with smooth change of web depth and face plate size.

1.7.2.3.1 The height and width of brackets interconnecting the members, or attaching them to bulkheads are, unless provided otherwise, to be not less than the members web depth (or the lesser web depth of the members connected). The bracket thickness is assumed equal to the lesser of the member web thicknesses. In member connections no gaps are permissible.

1.7.2.3.2 The brackets connecting the members shall have a face plate or flange along the free edge. In places of transition from the face plates of brackets to those of members, the width and thickness of the face plate along the free edge at different sizes of the member face plates shall change smoothly. The area of face plate (or flange) of tripping bracket shall be taken not less than 0,8 times the area of lesser face plate of the members connected.

If the distance, in mm, between bracket ends exceeds $l \geq 160s\sqrt{\eta}$, in mm, (s = thickness of bracket, in mm), a stiffener shall be fitted parallel to the line connecting bracket ends at the distance a equal to 1/4 of the bracket height or 35 times its thickness (whichever is less). The inertia moment of the stiffener shall be determined by Formula (1.6.5.6-2). Brackets shall be additionally stiffened depending on their size and configuration (refer to 1.7.3.2.2).

1.7.2.3.3 The radius of rounding shall not be less than the depth of the smaller members connected.

The webs and face plates shall be supported by stiffeners and tripping brackets in way of rounding (refer to Fig. 1.7.2.3.3).

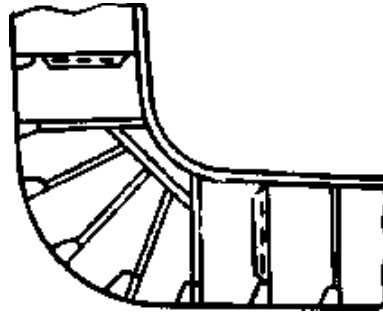

Fig. 1.7.2.3.3

1.7.2.4 The constructions used for the attachment of primary members to supporting members shall comply with existing standards.

1.7.3 Construction of deep members.

1.7.3.1 The depth h and thickness s_w of member webs (as well as of built-up primary members) and their sectional area are regulated by the relevant Chapters of this Part. The width of member face plate b , in mm, as measured from its web, shall not be more than

$$b = 200s_{fp} / \sqrt{R_{eH}}, \quad (1.7.3.1)$$

where s_{fp} – thickness of member face plate, in mm.

The thickness of face plate shall not normally exceed a triple thickness of the web plate.

1.7.3.2 Where $h/s_c \geq 160\sqrt{\eta}$, (for h and s_w , in mm, refer to 1.7.3.1), the webs of members (except for those whose buckling strength shall be checked in accordance with 1.6.5) shall be stiffened by tripping brackets and stiffeners (refer to Fig. 1.7.3.2).

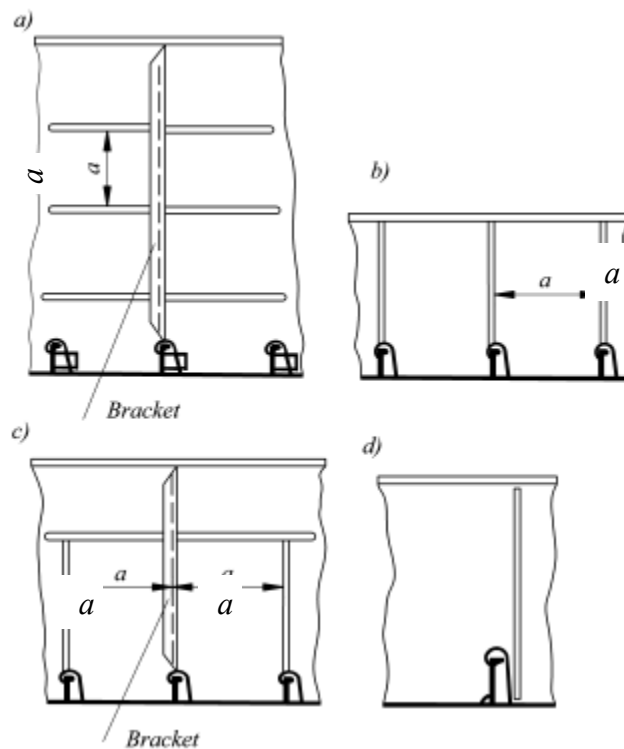

Fig. 1.7.3.2

1.7.3.2.1 Where $h/s_c \geq 160\sqrt{\eta}$, the webs of members shall be stiffened with the stiffeners fitted parallel to the member face plate (refer to Fig. 1.7.3.2, *a*). Where $h/s_c < 160\sqrt{\eta}$, stiffening may be carried out as shown in Figs. 1.7.3.2, *b*, *c*.

The spacing of stiffeners (width of non-stiffened web area), in mm, shall not be greater than $a = 90 \cdot s_c \cdot \sqrt{\eta}$.

In some cases, the structure shown in Fig. 1.7.3.2, *d* may be permitted

In way of portions equal to $0,2l$, but not less than $1,5h$ from supports (l and h are the span and depth of member web respectively), the spacing shall be reduced 1,5 times.

Stiffeners fitted normal to the face plate of the member supporting primary members (e.g. longitudinals, bulkhead stiffeners, frames, etc.) shall be fitted not further than in line with every second member in question.

Variation from the above spacing of stiffeners may be permitted on the basis of the results of direct strength calculation.

1.7.3.2.2 The thickness of stiffener shall not be less than $0,8s_w$. Moment of inertia of the stiffeners is determined according to 1.6.5.6.

1.7.3.2.3 The tripping brackets stiffening deep members shall be fitted at the toes of brackets securing the members in way of rounding and struts as well as in way of span of the member (refer to Figs. 1.7.3.2, *a*, *b*). In any case, the spacing of brackets shall not exceed $3,0m$ or $15b_{f,p}$ ($b_{f,p}$ – full width of face plate, in mm), whichever is less.

The thickness of the tripping brackets shall be not less than required for the member web. The brackets shall be extended to the member face plate and be welded to it if the width of the face plate exceeds 150 mm, as measured from the member web to the free edge of face plate. The width of the bracket section being welded shall be at least 10 mm smaller than the face plate width. Where the width of face plates symmetric to the member web exceeds 200 mm, small brackets shall be fitted at the opposite side of the web in line with the tripping bracket.

The width of the tripping brackets, measured at the base shall not be less than half their depth.

The bracket shall have a face plate or flange if the length of free edge $l > 60s$ (s – thickness of bracket, in mm). The width of the face plate or flange shall not be less than l/s .

Face plates or flanges ends of the tripping brackets shall be sniped.

1.7.3.3 Lightening holes, cut-outs for the passage of framing members, etc. are permitted in the member webs.

The total depth of openings in the same section shall not exceed 0,5 of the member depth. For deck transverses, deck girders, webs and girders of watertight bulkheads in dry cargo ships, this value may be increased to 0,6 of the member depth.

The distance from the edges of all openings in deep members to the edges of cut-outs for the passage of primary members shall not be less than the depth of these members. The openings in deep member webs, except for cut-outs for the passage of primary members, shall be located at a distance not less than half the deep member depth from the toes of brackets attaching this member. Where it is impossible to satisfy this requirement, compensation shall be provided by local thickening of the web, fitting of collars, etc.

In all cases, the sectional area of a deep member (excluding openings) shall not be less than required in the relevant chapters of this Part.

For requirements regarding openings in floors, side girders and centre girder, refer to **2.4.2.7**.

1.7.4 Details of welded structures.

1.7.4.1 The face plates and/or webs shall be sniped at the member ends depending on the construction used for attachment of members.

1.7.4.2 The width of flange (face plate) of brackets shall not be less than 8 bracket thicknesses unless expressly provided otherwise in the relevant chapters of this Part.

1.7.4.3 The edges of brackets, face plates and webs of the members shall be welded all round and shall have no craters. This requirement also applies to air and drain holes and cut-outs for the passage of framing members and welded joints.

Where these openings are carried to the deck or bottom shell plating, their length as measured at the plating, shall comply with the requirements of **1.7.5.8**.

1.7.4.4 Welded joints shall be arranged in least stressed structural sections, as far as practicable from abrupt changes of sections, openings and details which were subject to cold forming.

1.7.4.5 The butt joints of face plates of the intersection girders under variable dynamic loads (e.g. in regions with high level of vibration) shall be made with smooth transition by means of diamond plates.

1.7.4.6 It is recommended that local concentration of welds, crossings of welds at an acute angle, as well as close locations of parallel butts or fillet welds and butt welds, be avoided. The distance between parallel welded joints, whatever their direction, shall not be less than:

200 mm between parallel butt welds;

75 mm between parallel fillet and butt welds;

50 mm between parallel fillet and butt welds on a length not exceeding 2 m.

The distance between welded joints may be reduced on the basis of appropriate technical background, which includes tests and strength calculations taking into account welding stresses and deformations.

The angle between two butt welds shall not be less than 60° (refer to Fig. 1.7.4.6).

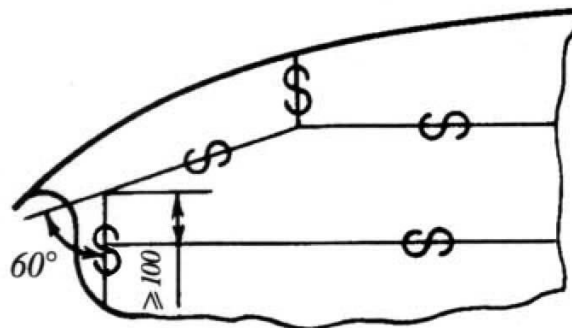

Fig. 1.7.4.6

1.7.4.7 The butts (seams) in assembling joints of the plating shall be located at a distance not less than 200 mm from the bulkheads, decks, inner bottom plating, deep members fitted parallel to the above-mentioned joints.

In assembling joints, the welded butts of built-up members shall be arranged so that the butts of a member web are not less than 150 mm clear of the butts of this member face plate.

The butts of webs and face plates may be arranged in the same plane provided that:

full penetration welding is ensured at the connection of the web to face plate on a length of at least 100 mm each side of the butt by non-destructive testing (NDT) (ultrasonic or radiographic testing) of the welded butt in every third member;

overlapping of the butt by the framing elements (knees, brackets, etc., fitted in line with the web) is ensured on a length not less than the face plate width each side of the butt.

1.7.5 Types and dimensions of fillet welds.

1.7.5.1 The design throat thickness a , in mm, of fillet welds for tee-connections for manual and semiautomatic welding shall not be less than:

$$a = \alpha\beta s, \quad (1.7.5.1)$$

where α – weld factor given in Table 1.7.5.1-1. For structures inside cargo tanks of tankers α shall be increased by 0,05;

β – factor given in Table 1.7.5.1-2 depending on the ratio of weld pitch t , in mm, to weld length l , in mm (refer to Fig. 1.7.5.1-1);

s – thickness of the lesser of the parts joined.

The relationship between the leg length of the fillet weld and the height of the isosceles triangle inscribed into the cross section of the weld (refer to Fig. 1.7.5.1-2) shall be assumed as $k = 1,4a$ or $a = 0,7k$. When automatic welding is employed instead of the proposed manual welding, the weld throat or leg length, whichever is adopted in calculation, may be reduced in height for single-run welds by not more than 30 per cent.

The throat thickness a of a fillet weld shall not be less than:

2,5 mm for $s \leq 4$ mm;

3,0 mm for $4 < s \leq 10$ mm;

3,5 mm for $10 < s \leq 15$ mm;

0,25s mm for $s > 15$ mm.

The dimensions of fillet welds taken from calculations shall not exceed $a \leq 0,7s$ ($k \leq s$).

Table 1.7.5.1-1

Nos.	Connection of structural members	Weld factor α
1	2	3
1	Double bottom	
1.1	Centre girder and duct keel to plate keel	0,35
1.2	Ditto to inner bottom plating	0,25
1.3	Ditto to inner bottom plating in the engine room and in way of thrust bearings	0,35
1.4	Floors to centre girder and duct keel under engines, boilers, thrust bearings and within 0,25L from F.P.	0,35
1.5	Floors to centre girder and duct keel elsewhere	0,25
1.6	Floors to margin plate and inner bottom plating under the corrugated bulkhead plates	0,35
1.7	Watertight floors, portions of side girders or centre girder round the boundaries of tanks, plating of bilge wells to their bottom plates and to inner bottom, floors and side girders	0,35
1.8	Floors and side girders to shell plating within 0,25L from F.P.	0,25
1.9	Ditto, elsewhere	0,20
1.10	Floors and side girders to inner bottom plating under engines, boilers and thrust bearings	0,25
1.11	Ditto, elsewhere	0,15
1.12	Floors to side girders within 0,25L from F.P.	0,25
1.13	Ditto, elsewhere	0,20
1.14	Margin plate to shell plating	0,35
1.15	Inclined margin plate to inner bottom plating	0,35
1.16	Bracket floors: bottom frames and brackets to shell plating	0,15
1.17	Reverse frames and brackets to inner bottom plating	0,10
1.18	Brackets, frames (refer to 2.4.4.5) to duct keel, plate keel, shell and inner bottom	0,35

	plating	
1.19	With longitudinal framing, bottom transverses to shell, inner bottom plating, centre girder and duct keel, margin plate where the floor spacing is less than 2,5 m outside the regions defined in 1.4 and 1.7	0,25
1.20	Ditto, with floor spacing 2,5 m and more, in all regions	0,35
1.21	Longitudinals to shell plating within 0,25L from F.P.	0,17
1.22	Ditto, with floor spacing 2,5 m and more, in all regions	0,35
1.23	Longitudinals to inner bottom plating	0,10
1.24	Brackets (refer to 2.4.2.5.2) to shell plating, margin plate, inner bottom plating and longitudinals	0,25
2	Single bottom	
2.1	Centre girder to plate keel	0,35
2.2	Centre girder to face plate	0,25
2.3	Floors to centre girder and longitudinal bulkheads	0,45
2.4	Floors and side girder webs to their face plates and to shell plating under engines, boilers and thrust bearings, as well as in the after peak	0,25
2.5	Floors and side girder webs to shell plating elsewhere	refer to 1.8, 1.9, 1.19 i 1.20
2.6	Floors and side girder webs to their face plates elsewhere	0,15
2.7	Side girder webs to floors	0,20
2.8	Bottom longitudinals to shell plating	refer to 1.21 i 1.22
3	Side framing	
3.1	Frames (including web frames) and side stringers to shell plating within 0,25L from F.P. in tanks, in the engine room, in way of ice strengthening and strengthening of sides of ships mooring at sea alongside other ships or offshore units	0,17
3.2	Ditto, elsewhere	0,13
3.3	Frames (including web frames) and side stringers to their face plates in regions defined in 3.1	0,13
3.4	Ditto, elsewhere	0,10
3.5	Frames (including web frames) and side stringers to shell plating in the after peak	0,25
3.6	Ditto to their face plates	0,17
3.7	Side stringers to web frames	0,25
3.8	Side longitudinals to shell plating	0,17
3.9	Ditto to face plates	0,13
3.10	Bilge brackets to margin plate and face plates of floors outside double bottom	0,35 ¹
3.11	Ditto to shell plating	0,25
4	Deck framing and decks	
4.1	Deck transverses and girders to deck plating	0,17
4.2	Ditto to their face plates	0,13
4.3	Cantilever beams to deck plating and to their face plates	0,25
4.4	Webs of deck transverses to girder webs and bulkheads	0,25
4.5	Beams in way of tanks, fore and after peaks, as well as hatch end beams, to deck plating	0,15
4.6	Ditto, elsewhere	0,10
4.7	Deck longitudinals to deck plating and their face plates	0,10
4.8	Stringer plate of strength deck to shell plating	0,45 ²
4.9	Ditto for other decks and platforms	0,35 ¹
4.10	Hatch coamings to deck plating at hatch corners	0,45 ²
4.11	Ditto, elsewhere	0,35 ³
4.12	Face plates of hatch coamings to vertical plates of same	0,25
4.13	Stays, horizontal and vertical stiffeners to vertical plates of hatch coamings	0,20
4.14	Side and end bulkheads of superstructures and deckhouses to deck plating	0,35
4.15	Other bulkheads of superstructures and deckhouses to deck plating	0,25
4.16	Bulwark stays to bulwark plating	0,20
4.17	Bulwark stays to deck and guard rails	0,35
4.18	Pillars to deck and inner bottom, pillar brackets to pillars, decks, inner bottom and other structures	0,35
5	Bulkheads and partitions	
5.1	Fore and after peak bulkheads, tank (cargo oil tank) boundaries, bulkheads (including	0,35

	wash bulkheads) inside after peak around the perimeter	
5.2	Other watertight bulkheads (including wash bulkheads) to bottom shell or inner bottom plating, shell plating in way of the bilge	0,35
5.3	Ditto to sides and deck	0,25
5.4	Vertical box corrugations of corrugated bulkheads to inner bottom plating or upper strake of lower stool	0,35
5.5	Shaft tunnel plating all round	0,35
5.6	Vertical and horizontal stiffeners to bulkhead plates under 5.1, and to wash bulkheads	0,15
5.7	Ditto of other bulkheads	0,10
5.8	Vertical webs and horizontal girders to bulkhead plates according to 5.1, and to wash bulkheads	0,17
5.9	Ditto to their face plates	0,13
5.10	Vertical webs and horizontal girders to plating of other bulkheads	0,13
5.11	Ditto to their face plates	0,10
5.12	Transverse bulkheads to wash bulkheads	0,35 ¹
6	Brackets and stiffeners	
6.1	Brackets for interconnection of structural members	0,35 ³
6.2	Stiffeners and tripping brackets (refer to 1.7.3.2) of deep members, floors, etc	0,10
7	Foundations for main engines, boilers and other machinery	
7.1	Vertical plates to shell, inner bottom and deck plating	0,35 ⁴
7.2	Top plates (face plates) to longitudinal girders, brackets, knees	0,45 ²
7.3	Brackets and knees of foundations to vertical plates, shell plating, inner bottom (floor face 0,353 plates) and to deck plating	0,35 ⁴
7.4	Brackets and knees to their face plates	0,25

¹ Double continuous weld shall be applied.

² Welding through the entire thickness is to be provided.

³ Fillet welds attaching face plates to member webs shall be welded in way of brackets with weld factor 0,35. The face plates shall be welded to the brackets by the same weld as that of the face plate of the member in the span between the bracket.

⁴ The structures under the girder webs, brackets and knees of foundations shall be welded to the inner bottom and decks by double continuous fillet welds with factor 0,35.

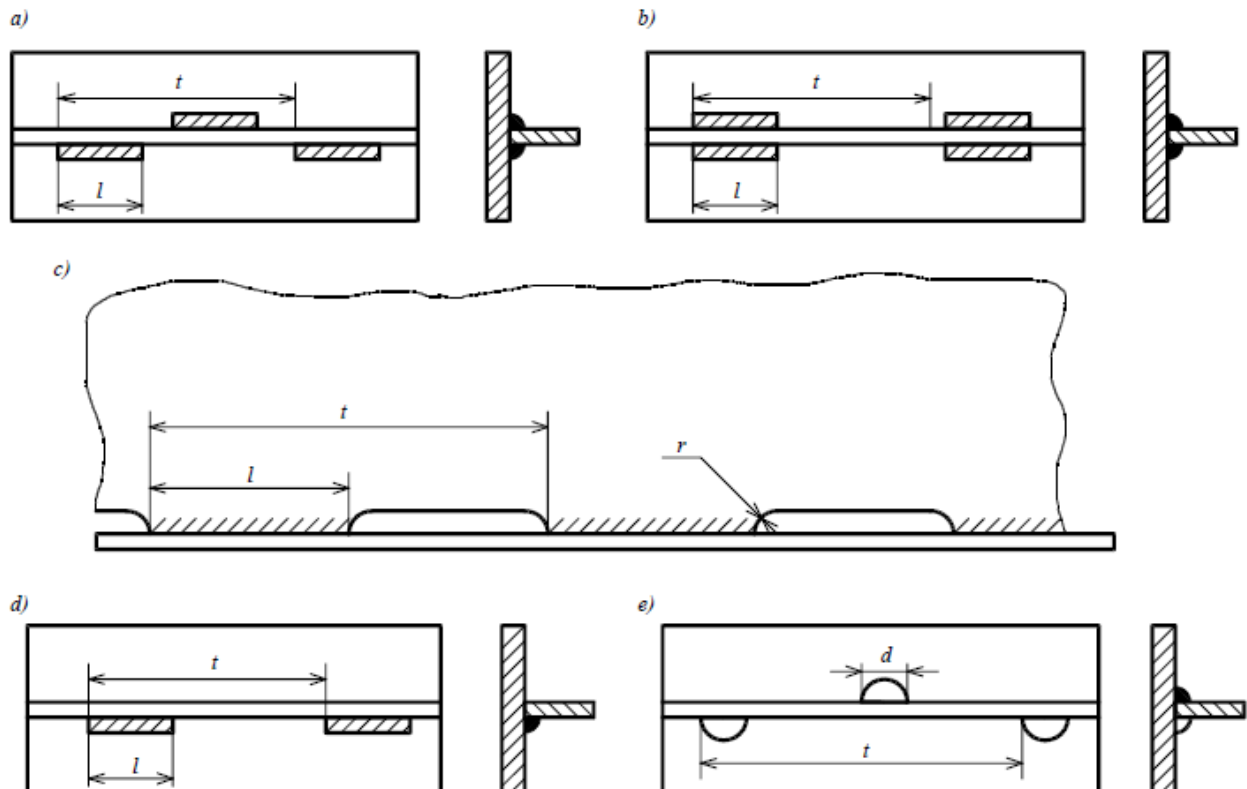

Fig. 1.7.5.1-1

Weld types: *a* - staggered intermittent; *b* - chain intermittent; *c* - scalloped; *d* - single intermittent; *e* - staggered spot

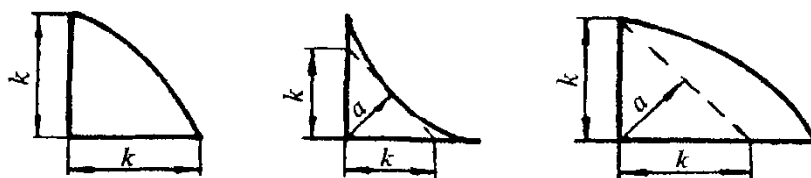

Fig.1.7.5.1-2.

Table 1.7.5.1-2

Type of fillet weld	β
	1
Double continuous	1,0
Staggered, chain and scalloped	t/l
Single continuous	2,0
Single intermittent	$2t/l$

1.7.5.2 Overlapping connections, if allowed (refer to **1.7.2.1**), shall be welded all round by continuous weld with factor 0,4. The length of overlap, in mm, shall be not less than $b = 2s + 25$, but not more than 50 mm (s =thickness of the thinner of the plates joined).

1.7.5.3 The primary members (beams, deck longitudinals, frames, bulkhead stiffeners, etc.) shall be connected to supporting members (deck girders, deck transverses, side stringers, horizontal girders, etc.) by welds with factor 0,35.

The sectional area f , in cm^2 , of the welds connecting the primary members to supporting members shall not be less than determined by the formula:

$$f = 25pa / \sigma_n, \quad (1.7.5.3)$$

where p – pressure, in kPa, specified in appropriate Chapters of this Part;

a – spacing of members, in m;

l – span of member, in m;

for σ_n – refer to **1.1.4.3**.

The weld sectional area f , in cm^2 , is determined by summing up the results obtained by multiplying the throat thickness by the weld length of each portion of the connection of member web to supporting member.

1.7.5.4 The framing members cut at intersection with other structures shall be in good alignment. A non-alignment shall not exceed half the thickness of the member. Where continuity is obtained by directing welding of the members to the structure involved, the throat thickness of the weld shall be determined considering the thickness of the member concerned. Otherwise, through penetration welding shall be performed. If the thickness of the thinner of the parts joined is less than 0,7 of the thickness of the other part, the throat thickness shall be calculated with regard to the particular loads in way of the intersection.

Where longitudinals are cut at transverse bulkheads, the construction used for their attachment shall comply with the following requirements:

1 when the brackets are fitted in line on both sides of the bulkhead, the area f_1 , in cm^2 , of the weld connecting the brackets (and the longitudinal butt ends, if they are welded) to transverse bulkheads (refer to Fig. 1.7.5.4.1 *a*) shall not be less than determined by the formula:

$$f_1 = 1,75S_0, \quad (1.7.5.4.1)$$

where S_0 – cross-sectional area of the longitudinal (effective flange excluded), in cm^2 .

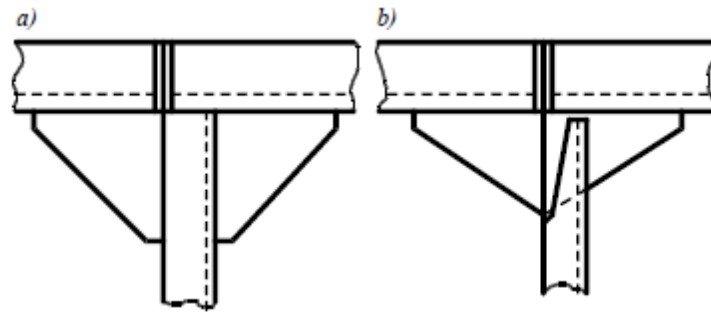

Fig. 1.7.5.4.1

.2 if one continuous bracket plate welded in the appropriate slot cut in the bulkhead plating is fitted (refer to Fig. 1.7.5.4.1 *b*), the sectional area of the bracket at the bulkhead shall not be less than $1,25S_0$.

.3 the arm length l_{br} , in mm, of the bracket, in mm, over the longitudinals shall not be less than determined by the formula:

$$l_{br} = \frac{1,75S_0 - S_1}{2a} \cdot 10^2 \quad (1.7.5.4.3)$$

where S_1 – area of weld connecting longitudinal butt ends to transverse bulkheads, in cm^2 ;

a – accepted design thickness of fillet weld connecting bracket to longitudinal, in mm.

1.7.5.5 Where plate thickness exceeds 18 mm, for connections made by fillet welds in which excessive stress in Z-direction may be caused by welding process or by external loads, Z-steel (refer to **1.2.2.2**) shall be used or structural measures shall be taken to prevent lamellar tearing. In all cases, reducing of residual stress level shall be provided.

1.7.5.6 Double continuous welds shall be used in the following regions (refer also to Footnote ¹ to Table 1.7.5.1-1):

.1 within $0,25L$ from the forward perpendicular in ships with length $L \geq 30$ m, for connection of framing members to bottom shell, and in case of only a single bottom in this region, also for welding of the webs of centre girder, side girders and floors to face plates of these members;

.2 in region **I** of ships of ice classes **Ice6**, **Ice5**, **Ice4**, in areas between *USWL* and *LSWL* ships of polar classes **PC1** ÷ **PC6**, ships of Baltic ice classes **IA Super** – **IB**, and in region **AI** of ships of ice class **Ice3** ice strengthening and in areas **B** and **BI** polar class ships **PC7**, and in bow area of Baltic ice class ships **IC**, for connection of side framing to shell plating

.3 in way of foundations for machinery and equipment which may constitute a source of vibration (refer to **1.7.1.6**), for connection of framing members to bottom and inner bottom platings, deck framing to deck plating;

.4 for the structures in the after peak;

.5 in way of supports and member ends, for connection of framing members to the plating (refer to **1.7.5.8**);

.6 in tanks (including double bottom tanks), exclusive the tanks for fuel oil or lubricating oil;

.7 for structures providing tightness.

1.7.5.7 Single continuous welds shall not be used:

.1 within $0,2L$ from F.P. for connection of side framing to shell plating, and within $0,25L$ from F.P. for connection of bottom framing to shell plating;

.2 for structures subject to intense vibration (refer to 1.7.1.6);

.3 in region **I** of ice strengthening of ships;

.4 for welding of side framing in ships mooring alongside other ships at sea or offshore units;

.5 for connections where the angle between a member web and the plating differs by more than 10° from a right angle.

1.7.5.8 For all types of intermittent joints the weld length l (refer to Fig. 1.7.5.1-1) shall not be less than $15a$ (for a , refer to 1.7.5.1) or 50 mm, whichever is the greater. The spacing of welds ($(t - l)$ – for chain welds and scalloped framing, and $(t - 2l) / 2$ for staggered welds) shall not exceed $15s$ (s – plate thickness or web thickness, whichever is less). In any case, the spacing of welds or scallop length, where scalloped frames are used, shall not exceed 150 mm.

Intermittent or single continuous welds connecting the framing members to the plating shall be substituted in way of supports and member ends by double continuous welds having the same throat thickness as the intermittent or single continuous welds of the remaining part of the members. The length of joints welded from both sides shall be not less than the sum of bracket arm and the web depth, if a bracket is fitted, and shall be twice the web depth if no bracket is fitted. Where the framing members pass through supporting structures (deck transverses, deck girders, floors, etc.), the aforesaid reinforcement shall be provided on both sides of supporting member. Where single continuous welds are used, back runs at least 50 mm long and spaced not more than 500 mm apart shall be welded on the reverse side of the detail joined.

The throat thickness of back weld shall be the same as that of the single continuous weld.

1.7.5.9 Staggered spot welds and single intermittent welds (refer to Fig. 1.7.5.1-1, d and e) may be used in the structures of deckhouses and superstructures of the second tier and above, on decks inside first tier superstructures, casings, enclosures inside the hull, not subject to intense vibration and impact loads and not affected by active corrosion, provided that the maximum plate or member web thickness is not more than 7 mm. The spot diameter d , in mm, shall not be less than:

$$d = 1,12\sqrt{\alpha ts}, \quad (1.7.5.9)$$

where t – pitch of spot weld (refer to Fig. 1.7.5.1-1);

$t_{\max} = 80$ mm;

for α , s – refer to **1.7.5.1**.

If $d > 12$ mm, as determined by the Formula (1.7.5.9), the weld pitch shall be increased or another type of weld shall be chosen.

1.7.5.10 Scalloped construction shall not be used:

.1 for side framing within $0,2L$ from F.P. and for connection of framing members to bottom shell plating within $0,25L$ from F.P.;

.2 in regions with high level of vibration (refer to **1.7.1.6**);

.3 for side and bottom framing in region **I** of ice belt and for side framing in ships mooring at sea alongside other ships or offshore units;

.4 for connection of bottom centre girder to plate keel;

.5 for deck and inner bottom framing in locations where containers, trailers and vehicles may be stowed and for upper deck framing under deckhouses in way of their ends at a distance less than $0,25$ of the deckhouse height from the intersection of deckhouse side and end bulkhead.

1.7.5.11 In scalloped construction (refer to Fig. 1.7.5.1-1) the welding shall be carried round the ends of all lugs. The depth of scallop in member web shall not exceed $0,25$ of the member depth or 75 mm, whichever is less. The scallops shall be rounded with radius not less than 25 mm. The spacing of lugs l shall be not less than the length of the scallop. Scallops in frames, beams, stiffeners and similar structures shall be kept clear of the ends of structures, as well as intersections with supporting structures (decks, side stringers, deck girders, etc.) by at least twice the member depth, and from the toes of the brackets by at least half the member depth.

1.7.5.12 In the framing of tanks (including double-bottom tanks and the tanks of tankers), provision shall be made for openings to ensure free air flow to air pipes, as well as an overflow of liquid.

It is recommended that openings in longitudinals shall be elliptical with a distance from the edge of opening to deck plating or bottom shell plating not less than 20 mm.

In way of air and drain holes, cut-outs for the passage of framing members and welded joints the joints shall be welded as double welds on a length of 50 mm on both sides of the opening.

1.7.5.13 Where welding of tee-joints by fillet welds is impracticable, plug welds (refer to Fig. 1.7.5.13 **a**) or tenon welds (refer to Fig. 1.7.5.13 **b**) may be used.

The length l and pitch t shall be determined as for scalloped frames under **1.7.5.11**.

For plug welding, the slots shall be of circular or linear form, with throat thickness of weld equal to $0,5$ of plate thickness. In general, the ends of slots in plug welding shall be made semicircular. The linear slots

shall be arranged with longer side in the direction of the parts to be joined (refer to Fig. 1.7.5.13, **a**).

Complete filling of slot is not permitted.

In regions of high level of vibration (refer to **1.7.1.6**) welded joints with complete root penetration and permanent backing ring (refer to Fig. 1.7.5.13 **c**) are recommended instead of tenon welds or plug welds.

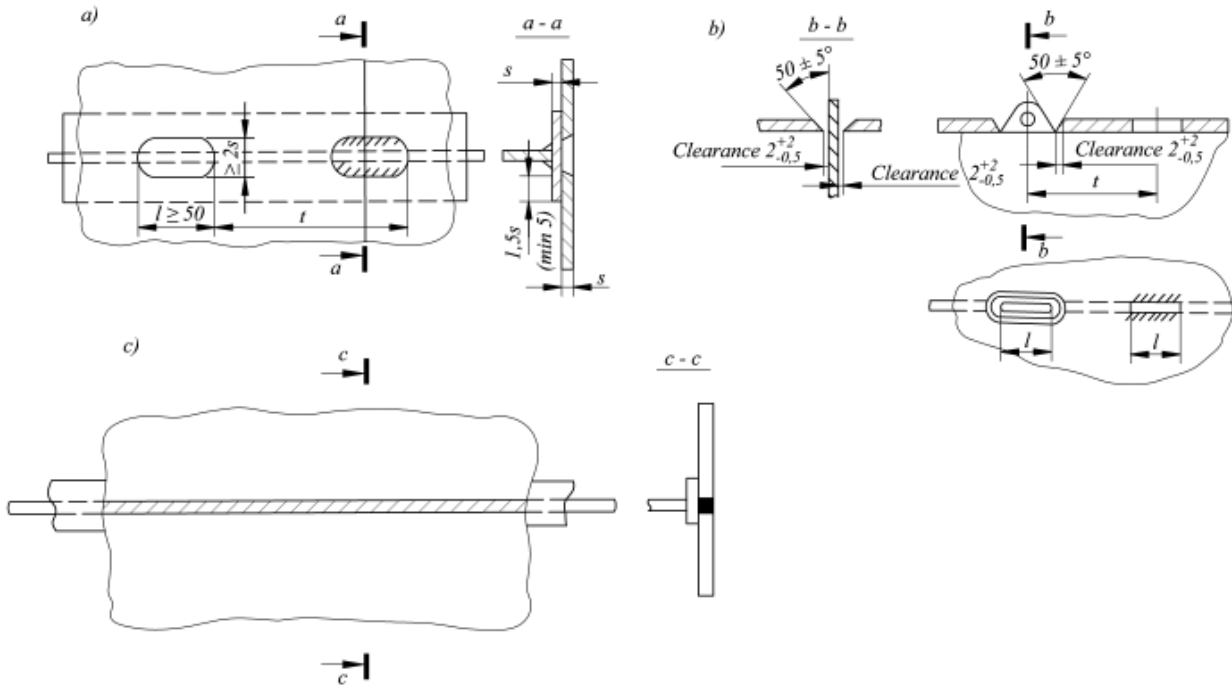

Fig. 1.7.5.13

1.7.5.14 Where aluminium alloy structures are welded according to Table 1.7.5.1-1, it is not permitted:

- .1 to use intermittent welds (except in scalloped construction);
- .2 to use scalloped construction in regions of high level of vibration (refer to **1.7.1.6**).

The throat thickness of welds shall be not less than 3 mm, but not more than $0,5s$ (for s , refer to **1.7.5.1**).

2. GENERAL REQUIREMENTS FOR HULL STRUCTURES

2.1 GENERAL

2.1.1 Application.

The requirements given in this Section apply to sea-going ships of all types and purposes, having regard to additional provisions of Section 3. This Section contains the requirements for hull structures: shell plating, platings, primary and deep members, pillars, stems, sternframes, seatings, etc.

2.1.2 Symbols.

L_1 – length of the compartment, in m, measured as follows:

with plane bulkheads, as the distance between bulkhead platings;

with corrugated bulkheads, as the distance between corrugation axes or the axes of trapezoidal stools at the inner bottom level;

with cofferdam bulkheads, as the distance between middle cofferdam axes;

B_1 – breadth of the compartment, in m, measured at its mid-length as follows:

for single skin construction, as the distance between the sides or between the side and the longitudinal bulkhead at the upper edge of the floor;

for double skin construction, as the distance between inner skins or between the inner skin and the longitudinal bulkhead;

where hopper side tanks are fitted, as the distance between hopper tanks at the inner bottom level or between the longitudinal bulkhead and the hopper side tank;

where several longitudinal bulkheads are fitted, as the spacing of longitudinal bulkheads or as the distance between the longitudinal bulkhead nearest to the side and the appropriate side;

l – span of the member, in m, defined in **1.6.3.1**, unless provided otherwise;

h – depth of the member web, in cm;

a – spacing of primary or deep members concerned (longitudinal or transverse framing); where the spacing varies, a is the half-sum of the distances of adjacent members from the member concerned;

s – plate thickness, in mm;

W – section modulus of members, in cm³;

I – moment of inertia of members, in cm⁴;

Δs – corrosion allowance to the plate thickness, in mm (refer to **1.1.5.1**);

ω_k – corrosion allowance to the plate thickness, in mm (refer to **1.1.5.3**);

j_k – factor taking account of corrosion allowance to the section modulus of members (refer to **1.1.5.3**).

2.2 SHELL PLATING

2.2.1 General and symbols.

2.2.1.1 Requirements are given in this Chapter for the thickness of bottom and side shell plating, thickness and width of sheerstrake, plate keel, garboard strakes, as well as the requirements for the minimum structural thicknesses of these members and construction of openings therein. The requirements are applicable to all regions over the ship's length and depth unless additional requirements for shell plating thickness are put forward.

Special requirements to reinforcement of the bottom and side plating in the end parts are specified in **2.8**, and special requirements to shell plating of ice class ships – in **3.10**.

2.2.1.2 For the purpose of this Chapter the following symbols have been adopted.

p_{st} – design static pressure according to 1.3.2.1;

p_w – design pressure due to the motion of ship hull about wave contour according to 1.3.2.2;

p_c – design pressure from carried liquid cargo, ballast or oil fuel according to 1.3.4.2.1;

r – opening radius, in m.

2.2.2 Construction.

2.2.2.1 No openings shall be cut in the upper edge of sheerstrake or in the side shell plating if the distance between the upper edge of opening and the strength deck is less than half the opening depth.

Rectangular openings cut in the side shell plating shall have their corners rounded with the radius equal to 0,1 of the opening depth or width, whichever is less, but not less than 50 mm.

In all cases when the openings may result in considerable reduction of longitudinal or local strength of the ship, provision shall be made for reinforcement of such areas.

Reinforcement by means of thickened insert plates is required for openings located within $0,35L$ from the midship region, the distance from their upper edge to the strength deck being less than the depth of opening. The minimum width of thickened insert plates, as measured from the upper or lower edge of opening, shall be equal to $0,25$ of the depth or length of the opening, whichever is less; the total width measured outside the opening shall be greater than the minimum thickness by at least $0,25$ of the depth or length of the opening, whichever is less. The minimum distance from the end of the thickened insert plate to the nearest edge of opening, as measured along the length, of the ship shall be equal to at least $0,35$ of the depth or length of opening, whichever is less. The corners of the thickened insert plate shall be rounded. The thickness of the thickened insert plate shall not be less than:

$1,5 s$ when $s < 20$ mm;

30 mm when $20 \leq s \leq 24$ mm;

$1,25 s$ when $s > 24$ mm,

where s — thickness of shell plating in way of the opening.

A thickened insert plate may be fitted around the perimeter of the opening.

In ships of restricted areas of navigation **R2-S, R2-RS, A-R2-S, A-R2-RS, B-R3-S, B-R3-RS, C-R3-S, C-R3-RS, R3-S, R3-RS, R3, R3-IN, D-R3-S, D-R3-RS**, with shelter upper decks or deck stringers of a longitudinal cargo hatch coamings or the like, all the top free edges of the above structures, as well as free edges of large cutouts in shell plating shall be smooth in the ship's hull longitudinal direction and rounded in the transverse one.

2.2.2.2 The area of transition from sheerstrake to deck stringer may be rounded. In this case, the radius of curvature of sheerstrake shall not be less than 15 times the sheerstrake thickness.

No openings are permitted in the rounded area.

2.2.3 Loads on shell plating.

The external pressure p , in kPa, on the bottom and side shell plating is determined by the formula:

$$p = p_{st} + p_w. \quad (2.2.3-1)$$

For ships with double bottom and double skin side construction intended for liquid ballast and for tankers with neither double bottom nor double skin side construction, the internal pressure $p = p_c$ shall be determined additionally by Formulae **1.3.4.2.1**.

Where $p_{st} > p_w$, counterpressure shall be considered:

$$p = p_c - (p_{st} - p_w). \quad (2.2.3-2)$$

For ships with double bottom and double skin side construction p_{st} and p_w shall be determined in accordance with **1.3.2** as in the case of the ballasted ships.

As the design pressure, both external and internal pressure may be adopted, whichever is the greater.

The pressure p_w above the summer load waterline shall not be less than p_{min} , in kPa, determined by the formula:

$$p_{min} = 0,03L + 5 \quad (2.2.3-3)$$

Where $L > 250$ m L shall be taken equal to 250 m.

For ships of restricted area of navigation, the value of p_{min} may be reduced by multiplying by the factor φ_r , obtained from Table 1.3.1.5.

2.2.4 Scantlings of plate structures of shell plating.

2.2.4.1 The thickness of bottom and side shell plating shall not be less than determined by Formula (1.6.4.4) taking:

$m = 15,8$;

for bottom shell plating:

$k_\sigma = 0,3 \cdot k_b \leq 0,6$ in the midship region for $L \geq 65$ m and transverse framing system;

$k_\sigma = 0,6$ in the midship region for $L = 12$ m and transverse framing system.

Where $12 \text{ m} < L < 65 \text{ m}$ k_σ shall be determined by linear interpolation taking $k_\sigma = 0,45$ for $L = 65 \text{ m}$;

$k_{\sigma} = 0,6$ in the midship region for longitudinal framing system;

$k_{\sigma} = 0,7$ at the ends of the ship within $0,1L$ from the fore or after perpendicular.

For regions between the midship region and the above portions of ship's ends k_{σ} shall be determined by linear interpolation;

for side shell plating in way of $(0,4 - 0,5) \cdot D$ from the base line:

$k_{\sigma} = 0,6$ in the midship region;

$k_{\sigma} = 0,7$ at the ends of the ship within $0,1L$ from the fore or after perpendicular.

For regions between the midship region and the above portions of ship's ends k_{σ} shall be determined by linear interpolation.

For region below $0,4D$ from the base line, k_{σ} is determined by linear interpolation between the values of k_{σ} for bottom shell plating and those for side shell plating in way of $(0,4 - 0,5) \cdot D$ from the base line.

For region above $0,5D$ from the base line, k_{σ} is determined by linear interpolation between k_s for upper deck level and k_s for side shell plating in way of $(0,4 - 0,5) \cdot D$ from the base line;

k_{σ} for upper deck level is determined in the same way as k_s for bottom shell plating, parameter k_b being substituted for parameter k_d .

$$k_b = W_b^{\Phi} / (\eta \cdot W); \quad k_d = W_d^{\Phi} / (\eta \cdot W), \quad (2.2.4.1)$$

where: W – required hull section modulus amidships in accordance with 1.4.6 and assuming $\eta = 1$;

W_b^{Φ} i W_d^{Φ} – actual section moduli for bottom and deck amidships according to 1.4.8;

η - factor indicating application of the steel mechanical properties for the member for which k_{σ} is determined, to be established on the basis of 1.1.4.3.

2.2.4.2 The buckling strength of bottom plating, strake above bilge, sheerstrake and strake below in the midship region of ships over 65 m in length shall be verified in accordance with 1.6.5.

2.2.4.3 The thickness of bilge strake shall be adopted equal to that of bottom or side shell plating, whichever is the greater.

2.2.4.4 The width of plate keel b_k , in mm, shall not be less than:

$$b_k = 800 + 5L, \quad (2.2.4.4)$$

in this case, b_k need not exceed 2000 mm.

The thickness of plate keel shall be 2 mm greater than that of bottom shell plating.

2.2.4.5 The sheerstrake width b_s , in mm, shall not be less than determined by Formula (2.2.4.4) taking b_s not greater than 2000 mm.

The sheerstrake thickness amidships shall not be less than that of adjoining strakes of side shell or deck plating (stringer plate), whichever is the greater.

At ends, the sheerstrake thickness may be equal to that of side shell plating in this region.

2.2.4.6 The shell plates adjoining the sternframe, as well as the plates to which the arms of propeller shaft brackets are attached, shall have a thickness s , in mm, of not less than:

$$s = 0,1L + 4,4, \quad \text{for } L < 80\text{m}; \quad (2.2.4.6-1)$$

$$s = 0,055L + 8, \quad \text{for } L \geq 80\text{m}. \quad (2.2.4.6-2)$$

Where $L > 200$ m, L shall be taken equal to 200 m.

The aforesaid thickness shall be ensured after hot bending, if applied.

2.2.4.7 The thickness of garboard strakes directly adjoining the bar keel shall not be less than that required for the plate keel, and their width shall not be less than half the width required for the plate keel in accordance with 2.2.4.4.

2.2.4.8 In any case, the thickness of shell plating s , in mm, shall not be less than:

$$s_{\min} = 0,12L + 3,1 \text{ mm}, \quad \text{for } L < 30\text{m}; \quad (2.2.4.8-1)$$

$$s_{\min} = (0,04L + 5,5) \sqrt{\eta} \text{ mm}, \quad \text{for } L \geq 30\text{m}, \quad (2.2.4.8-2)$$

where: where for η – refer to **1.1.4.3**.

Where $L > 300$ m, L shall be taken equal to 300 m.

Where the adopted spacing is less than the standard one (refer to **1.1.3**) for ships of unrestricted service **A** and restricted area of navigation **R1** and **A-R1**, a reduction of minimum thickness of shell plating is permitted in proportion to the ratio of adopted spacing to standard spacing but not more than 10 per cent 10%.

For other ships restricted service – refer to **1.1.4.6**.

2.2.5 Special requirements.

2.2.5.1 The grade of steel used for the sheerstrake shall be the same as that used for the strength deck. The upper edge of sheerstrake shall be smooth, and their corners shall be well rounded in the transverse direction.

Requirement to the edge design covers also free edges of continuous longitudinal structures located above the sheerstrake and ensuring longitudinal strength of the ship's hull.

2.2.5.2 For ships of 65 m and above, within $0,6L$, amidships no parts shall be welded to the upper edge of sheerstrake or to the sheerstrake rounding.

2.2.5.3 Bilge keels shall be attached to the shell plating by means of an intermediate member, i. e. a flat bar welded to the shell plating with an allround continuous fillet weld. Connection of the bilge keel to this member shall be weaker than that of the member to the shell plating. However, the connection shall be strong enough to keep the bilge keels under the ordinary operating conditions of the ship. The intermediate member shall be made continuous over the length of bilge keel.

Bilge keels shall terminate in the stiffened area of shell plating and shall be gradually tapered at ends. The bilge keel and the intermediate member shall be of the same steel grade as the shell plating in this region.

2.3 SINGLE BOTTOM

2.3.1 General and symbols.

2.3.1.1 Requirements are given in this Chapter for the bottom framing of ships having no double bottom and in way where it is omitted, as well as for the floors, centre girder, bottom longitudinals and the brackets by which they are connected.

2.3.1.2 For the purpose of this Chapter the following symbols have been adopted:

L_1 – length of the compartment concerned (hold, tank, engine room, etc.), in m;

B_1 – breadth of the compartment concerned, in m, refer to **2.1.2**;

B_x – breadth of ship, in m, in way of considered section at the level of summer load waterline.

2.3.2 Construction.

2.3.2.1 In tankers of 80 m and above, longitudinal framing shall be provided for single bottom.

2.3.2.2 The structure of centre girder shall satisfy the following requirements:

1 the centre girder shall extend throughout the ship's length as far as practicable. In ships greater than 65 m in length, a continuous centre girder is recommended between transverse bulkheads;

2 when the bottom is framed longitudinally, the centre girder shall be stiffened on both sides with flanged brackets fitted between the bottom transverses and between bottom transverse and transverse bulkhead. The distance between brackets, between bracket and bottom transverse or between bracket and transverse bulkhead shall not exceed 1,2 m.

The brackets shall be carried to the face plate of the centre girder if the web of the latter is stiffened vertically or to the second horizontal stiffener from below if the centre girder web is stiffened horizontally.

In way of bottom plating, the brackets shall extend to the nearest bottom longitudinal and shall be welded thereto.

2.3.2.3 When the bottom is framed transversely, floors shall generally be fitted at every frame.

Where the floors are cut at the centre girder, their face plates shall be butt-welded to the face plate of the centre girder. If the actual section modulus of floors exceeds the value required by **2.3.4.1.2** less than 1,5 times, the width of their face plates shall be doubled, where attached to the centre girder face plate, or horizontal brackets of adequate size shall be fitted.

The floor face plates may be replaced by flanges.

Flanged floors are not permitted in way of engine room, in the after peak, and in ships of 30 m and above; they are not permitted within $0,25L$ from the fore perpendicular, either.

2.3.2.4 When the bottom is framed longitudinally, brackets shall be fitted in line with the bottom transverse web on both sides of the centre girder where the girder is higher than the bottom transverse at the place of their connection. A bracket shall be welded to bottom transverse face plate and to centre girder web

and face plate. The free edge of the bracket shall be stiffened with a face plate, and the angle of its inclination to bottom transverse face plate shall not exceed 45° .

Similar requirements apply to the connections of the stringer to bottom transverse where the stringer is higher than the bottom transverse at the place of connection.

2.3.2.5 In dry cargo ships, when the bottom is framed longitudinally, the spacing of side girders and the distance from the centre girder or ship's side to the side girder shall not exceed 2,2 m.

The side girder plates shall be cut at floors and welded thereto.

The face plates of side girders shall be welded to those of floors.

2.3.2.6 In tankers, the side girders, if fitted, shall form a ring system together with vertical stiffeners of transverse bulkheads and deck girders.

Deep side girders having the same depth as the centre girder, as well as conventional side girders having the same depth as bottom transverses, shall run continuous from one transverse bulkhead to another with $L_1/B_1 < 1$.

2.3.2.7 In the engine room, the centre girder may be omitted if the longitudinal girders under engine seating extend from the fore to the after bulkhead of the engine room and terminate with brackets beyond the bulkhead according to **2.3.5.1**.

2.3.2.8 In ships having a length of 65 m and more, the buckling strength of centre girder and side girders in the midship region shall be ensured in accordance with **1.6.5**.

The webs of centre girder, side girders and floors shall be stiffened in accordance with **1.7.3**.

2.3.2.9 Connections of bottom longitudinals to transverse bulkheads shall be such that the effective sectional area of the longitudinals is maintained.

2.3.2.10 When the bottom is framed longitudinally floors shall be fitted within the plane of side web frames, the spacing between floors or the distance between floors and transverse bulkhead shall be multiple to spacing and shall not exceed five spacings or 2,4m, whichever is less.

2.3.2.11 For hulls of a pontoon shape an alternative design and arrangement of the deck girders and transverses may be permitted, provided the additional longitudinal bulkheads are installed and strength of double bottom structures is verified by direct calculation according to the Register-agreed procedures.

2.3.3 Single bottom loads.

2.3.3.1 The design pressure on single bottom structures of dry cargo ships is the external pressure determined by Formula (2.2.3-1) for a ship in the ballast condition. When determining p_{st} in Formula (2.2.3-1), the ballast draught may be taken as 0,6 of the summer draught.

If a dry cargo ship is designed to operate in a fully loaded condition with some holds empty the static pressure p_{st} in Formula (2.2.3-1) for these holds shall be determined at summer draught.

2.3.3.2 As the design pressure on single bottom structures of tankers, external pressure determined by Formula (2.2.3-1) at summer draught is adopted, or the total pressure determined by Formula (2.2.3-2), whichever is the greater.

2.3.4 Scantlings of single bottom members.

2.3.4.1 The bottom with transverse framing shall satisfy the following requirements:

.1 the depth of floors at the centreline shall not be less than $0,055B_1$. In any case, B_1 shall not be taken less than $0,6B_x$.

Allowable reduction of floor depth shall not be more than 10 per cent, the required floor section modulus being maintained.

In the engine room, the height of floor web between longitudinal girders under the seating shall not be less than 0,65 of the required depth at the centreline. A reduction of floor section modulus by more than 10 % as compared to that required by **2.3.4.1.2** is not permitted.

At a distance of $3/8 B_x$ from the centreline, the depth of floors shall not be less than 50 per cent of the required depth of the centreline floors;

.2 at the centreline, the section modulus of floors shall not be less than determined according to **1.6.4.1** and **1.6.4.2** taking:

for p , refer to **2.3.3.1**, but it shall not be less than 35 kPa for dry cargo ships and not less than 85 kPa for tankers;

$l = B_1$, but at least $0,6B_x$;

$m = 13$;

$k_\sigma = 0,6$.

On portions equal to $0,05B_x$ from ship's side, the floor web sectional area shall not be less than determined according to 1.6.4.3 taking:

$$N_{\max} = 0,4pal;$$

$$k_{\tau} = 0,6.$$

When determining p and l , the above limitations shall be used;

.3 in accordance with **2.3.4.1.2**, the section modulus of centre girder shall be at least 1,6 times greater than the section modulus of a floor at the centreline. The depth of centre girder shall be equal to that of a floor at the place of their connection;

.4 the section modulus of a side girder shall not be less than the section modulus of a floor at the centreline in accordance with **2.3.4.1.2**.

The depth of side girder shall be equal to that of the floor at the place of their connection.

2.3.4.2 If longitudinal system of framing is adopted, the bottom members in way of the cargo tanks in tankers shall satisfy the following requirements:

.1 the section modulus of bottom longitudinals shall not be less than determined in accordance with **1.6.4.1** and **1.6.4.2** taking:

p – as defined in **2.3.3.2**;

$$m = 12;$$

$$k_{\sigma} = 0,45k_b \leq 0,65 \text{ in the midship region};$$

$$k_{\sigma} = 0,65 \text{ at the ends of the ship within } 0,1L \text{ from the fore or after perpendicular.};$$

k_b – shall be determined by Formula (2.2.4.1).

For regions between the midship region and the above portions of ship's ends, k_{σ} shall be determined by linear interpolation;

.2 the section modulus of a bottom transverse shall not be less than determined from **1.6.4.1** and **1.6.4.2**. Bottom transverse web sectional area, excluding openings, shall not be less than stipulated under **1.6.4.3** taking:

p – as defined in **2.3.3.2**;

$$l = B_1;$$

$$k_{\sigma} = k_{\tau} = 0,6;$$

for a wing tank

$$m = 18;$$

$$N_{\max} = 0,35pal;$$

for a centre tank

$$m = m_{b,t};$$

$$N_{\max} = 0,7n_{\phi}pal;$$

$m_{b,t}$ and $n_{b,t}$ shall be obtained from Table 2.3.4.2.2 depending upon the parameter m and the number of bottom transverses within a tank:

$$\mu = \alpha^{4/3}(L_1/B_1)^3;$$

$$\alpha = W_{b,t}/W_{c,g};$$

Table 2.3.4.2.2

μ	Number of transverses within a tank															
	2	3	4	5	2	3	4	5	2	3	4	5	2	3	4	5
	$m_{b,t}$				$m_{c,g}$				$n_{b,t}$				$n_{c,g}$			
0,01	96,0	95,9	95,9	95,8	27,3	21,7	25,5	23,3	0,253	0,255	0,256	0,257	0,329	0,370	0,393	0,409
0,02	95,8	95,6	95,4	95,1	27,6	22,1	26,0	23,9	0,256	0,260	0,261	0,264	0,326	0,367	0,387	0,401
0,04	95,4	95,4	93,9	92,7	28,3	22,8	27,1	25,0	0,261	0,269	0,271	0,277	0,318	0,355	0,375	0,387
0,06	94,7	92,7	91,8	89,3	28,9	23,5	28,1	26,2	0,267	0,277	0,281	0,289	0,311	0,346	0,364	0,374

0,08	93,9	90,5	89,2	85,5	29,6	24,3	29,1	27,4	0,272	0,286	0,290	0,301	0,304	0,337	0,354	0,363
0,1	92,9	88,1	86,3	81,5	30,2	25,0	30,2	28,6	0,276	0,293	0,298	0,311	0,298	0,329	0,344	0,352
0,2	86,5	75,1	72,1	64,0	33,4	28,9	35,5	34,7	0,298	0,326	0,333	0,352	0,269	0,294	0,304	0,307
0,3	79,6	64,0	61,1	52,3	36,6	32,8	40,9	41,0	0,316	0,352	0,359	0,382	0,246	0,266	0,273	0,274
0,4	73,3	55,7	53,1	44,7	39,8	36,9	46,5	47,6	0,330	0,373	0,380	0,404	0,226	0,243	0,249	0,249
0,6	63,2	44,9	43,3	36,1	46,2	45,4	58,0	61,6	0,354	0,404	0,409	0,436	0,195	0,206	0,213	0,214
0,8	56,1	38,5	37,6	31,5	52,6	54,4	70,1	76,6	0,371	0,426	0,429	0,457	0,171	0,184	0,188	0,189
1,0	51,0	34,4	34,0	28,6	59,0	64,0	82,8	93,1	0,386	0,443	0,445	0,471	0,153	0,165	0,170	0,171
1,2	47,2	31,6	31,6	26,9	65,4	74,2	96,6	110,8	0,397	0,456	0,456	0,482	0,138	0,150	0,155	0,158
1,5	43,1	28,8	29,1	25,0	75,0	90,7	117,0	141,1	0,410	0,471	0,469	0,492	0,120	0,132	0,139	0,142

$W_{b,t}$ – bottom transverse section modulus satisfying the present requirements;

$W_{c,g}$ – centre girder section modulus satisfying the requirements of 2.3.4.2.3.

The value of the parameter α is optional, but shall not exceed 0,6; the value of the parameter m shall not exceed 1,5.

Bottom transverse section modulus shall not be less than $\alpha W_{c,g}$;

.3 centre girder section modulus shall not be less than determined from 1.6.4.1 and 1.6.4.2. The sectional area of centre girder web shall not be less than stipulated under 1.6.4.3 taking:

p – as defined in 2.3.3.2;

$l = L_1$;

$m = m_{c,g}$;

$N_{\max} = 0,7n_{c,g}pal$;

$m_{c,g}$ and $n_{c,g}$ shall be obtained from Table 2.3.4.2.2 depending upon the parameter μ and the number of floors within a tank;

μ shall be determined in accordance with 2.3.4.2.2;

$k_{\sigma} = 0,35k_b \leq 0,6$ in the midship region;

$k_{\sigma} = 0,6$ at the ends of the ship within $0,1L$ from the fore or after perpendicular;

k_b – shall be determined by Formula (2.2.4.1).

For regions between the midship region and the above portions of ship's ends, k_{σ} shall be determined by linear interpolation.

$k_{\tau} = 0,6$.

The section modulus of centre girder shall not be less than $W_{b,t}/\alpha$, where $W_{b,t}$ – is bottom transverse section modulus satisfying the requirements of 2.3.4.2.2; α – shall be as stipulated under 2.3.4.2.2;

.4 in ships of 200 m and above, provision shall be made for side girders midway between longitudinal bulkhead and centre girder, as well as between longitudinal bulkhead and ship's side, in centre and wing tanks.

The section modulus of deep side girders, when fitted in accordance with 2.3.2.6, shall not be less than 0,5 of centre girder section modulus. The centre girder section moduli may be reduced in conformity with 2.3.4.2.3 and those of bottom transverse, in conformity with 2.3.4.2.2 by 15%.

The section modulus of conventional side girders, when fitted in accordance with 2.3.2.6, shall not be less than bottom transverse section modulus;

.5 alternatively to the requirements of 2.3.4.2.2 - 2.3.4.2.4, the scantlings of bottom transverses, centre girder and side girders may be selected proceeding from the calculation of bottom grillage, using beam models. In this case, design loads shall be chosen in accordance with 2.3.3.2, permissible stress factors, in accordance with 2.3.4.2.2 and 2.3.4.2.3, boundary conditions, proceeding from cargo distribution over the length and breadth of the ship and the type of structures adjoining the calculated one. The effect of brackets shall be considered.

2.3.4.3 in the engine room, the bottom transverse and side girder web thickness shall not be less than the centre girder web thickness.

If a girder acts as the vertical plate of engine seating, the girder thickness shall not be less than the vertical plate thickness as required by 2.11.3.

The depth of bottom transverse shall be increased in proportion to the height at which engine seatings are fitted.

2.3.4.4 The thickness, in mm, of single bottom members shall not be less than:

$$s_{\min}=5,3 + 0,04L \quad \text{for } L < 80\text{m}; \quad (2.3.4.4-1)$$

$$s_{\min}=6,5 + 0,025L \quad \text{for } L \geq 80\text{m}. \quad (2.3.4.4-2)$$

Where $L > 250$ m, L shall be taken equal to 250 m.

For the centre girder, s_{\min} shall be increased by 1,5 mm, but shall not exceed the plate keel thickness; floor web thickness need not exceed the bottom shell plating thickness.

In tankers, the minimum thickness of single bottom members shall also satisfy the requirements of **3.5.4**, whichever is the greater.

2.3.5 Special requirements.

2.3.5.1 End attachments of bottom members and deep member web stiffening shall satisfy the following requirements:

.1 centre girder and side girders shall be attached to transverse bulkheads by brackets. For size of brackets, refer to **1.7.2.3**.

.2 in dry cargo ships, the height of brackets may be reduced to half the centre girder depth if the face plate of centre girder is welded to the transverse bulkhead. In case the centre girder face plate is widened to at least twice the normal value in way of abutting upon the transverse bulkhead, the brackets need not be fitted. If the centre girder is not fitted in the engine room, then at discontinuities beyond bulkheads it shall be terminated in gradually tapered brackets of a length equal to twice the centre girder depth, but not less than three spacings.

.3 in tankers, the bottom transverses shall be attached to side transverses and/or vertical webs of longitudinal bulkheads by brackets. For size of brackets, refer to **1.7.2.3**.

The bottom transverses shall be attached to centre girder by brackets.

2.3.5.2 If transverse system of framing is adopted, the holes cut in floors shall have a diameter not exceeding half the floor depth in this location. The distance between the hole edge and floor face plate shall not be less than 0,25 times the floor depth in this location. The distance between the edges of adjacent holes shall not be less than the floor depth. Floor plates provided with holes shall be strengthened with vertical stiffeners.

2.3.5.3 The webs of side girders and floors shall be provided with drain holes.

2.4 DOUBLE BOTTOM

2.4.1 Загальні положення.

Requirements are given in this Chapter for double bottom structures including bottom framing up to the top of bilge rounding, inner bottom plating and framing, centre girder and duct keel, side girders and half-height girders, margin plate with stiffeners, brackets, knees and intermediate vertical stiffeners in the double bottom space, sea chests and drain wells.

Additional requirements for double bottoms are given in:

1.1.6.4 and **1.1.6.6** (passenger ships);

1.1.6.5 and **1.1.6.6** (cargo ships, other than tankers);

3.1 (container ships);

3.3 (bulk carriers and oil/bulk dry cargo carriers);

3.4 (ore carriers and ore/oil carriers);

3.10 (icebreakers).

2.4.2 Construction.

2.4.2.1 In tankers of 80 m in length, bulk carriers and ore carriers, as well as in oil/bulk dry cargo carriers and ore/oil carriers, the double bottom shall be framed longitudinally.

2.4.2.2 The centre girder shall extend fore and aft as far as practicable to the stem and sternframe and shall be attached to them whenever possible. The centre girder shall generally be continuous within at least $0,6L$ amidships. Where longitudinal framing is adopted in the double bottom, brackets shall be fitted on both sides of centre girder, which shall be spaced not more than 1,2 m apart, extended to the nearest longitudinal or lighthened side girder and welded thereto. The distance between brackets shall not exceed 1,2 m.

2.4.2.3 In lieu of centre girder, a duct keel may be fitted consisting of two plates arranged on both sides of the centreline. The duct keel shall be wide enough for the access to all its structures to be ensured.

Transverse members with brackets shall be fitted at every frame in way of the bottom and inner bottom plating between the side plates of the duct keel.

If longitudinal system of framing is adopted, brackets shall be fitted at every frame on both sides of the duct keel, similar to those used for the centre girder.

Where the duct keel fitted only over a part of the ship's length terminates and is transformed into the centre girder, the duct keel and centre girder plates shall overlap over a length of at least one frame spacing and shall terminate in brackets with face plates.

In this case, the length of the brackets shall not be less than three spacings if the transition areas lie within $0,6L$ amidships, and not less than two spacings elsewhere.

2.4.2.4 The design of side girders and margin plate shall satisfy the following requirements:

.1 the spacing of side girders and the distance between a side girder and centre girder or margin plate, as measured at the level of the double bottom plating, shall not exceed 4,2 m for transversely framed double bottom and 5,0 for longitudinally framed double bottom;

.2 if longitudinal framing is adopted in the double bottom, lightened side girders may be fitted on bottom and double bottom instead of longitudinals (for panels with large openings, refer to **2.4.2.7.2** and **2.4.2.7.4**);

.3 in the engine room, the arrangement of side girders shall be consistent with that of the engine, boiler and thrust block seatings, so that at least one of the longitudinal girders under the seating is fitted in line with the side girder. In this case, an additional side girder shall be provided under the seating in line with the second longitudinal.

Where side girders cannot be arranged under the seatings in line with longitudinal girders, additional side girders shall be fitted under each longitudinal girder.

Additional side girders may be replaced by half height side girders welded to the inner bottom plating and floors only;

.4 inclined margin plate, if fitted, shall extend throughout the double bottom length.

2.4.2.5 The arrangement and design of floors shall satisfy the following requirements:

.1 if transverse framing is adopted in the double bottom, plate floors shall be fitted at every frame:

in engine and boiler rooms;

at the fore end within $0,25L$ from the fore perpendicular;

in the holds intended for the carriage of heavy cargo and ore, as well as in holds from which cargo is regularly discharged by grabs;

in ships which may happen to be aground due to the ebb-tide in ports.

In other regions, plate floors may be fitted five spacings or 3,6 m apart, whichever is less.

In this case, provision shall be made for open floors (bracket or lightened).

Bracket floors consist of bottom and reverse frames connected with brackets at centre girder, side girders and margin plate (refer to Fig. 2.4.2.5.1-1).

Lightened floors consist of plate panels having large openings of a smooth shape between side girders (refer to Fig. 2.4.2.5.1-2);

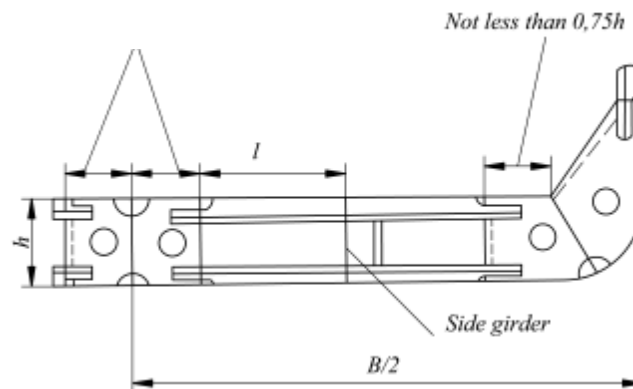

Fig. 2.4.2.5.1-1

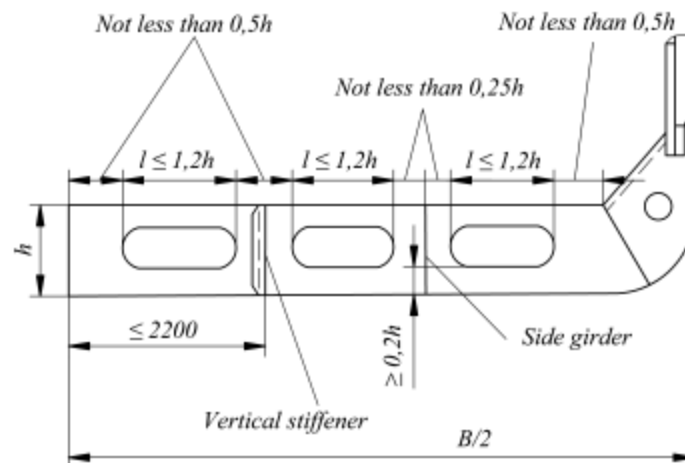

Fig. 2.4.2.5.1-2

.2 if longitudinal framing is adopted in the double bottom, plate floors shall generally be fitted at a distance not exceeding two spacings from each other:

in engine and boiler rooms; at the fore end within $0,25L$ from the fore perpendicular;

in the holds intended for the carriage of heavy cargo and ore, as well as in holds from which cargo is regularly discharged by grabs;

in ships which may happen to be aground due to the ebb-tide in ports.

In other regions, plate floors may be fitted five spacings or $3,6$ m apart, whichever is less. Where lightened side girders are fitted in lieu of bottom and double bottom longitudinals (refer to **2.4.2.4.2**), the above spacing may be increased, but not more than twice.

When the ship's side is framed transversely and double bottom is framed longitudinally, brackets shall be fitted at every frame between plate floors to stiffen the margin plate, which shall be carried to the nearest bottom and inner bottom longitudinals or to the nearest additional side girder, and welded thereto (refer to Fig. 2.4.2.5.2).

Under the seating of main engine, plate floors shall be fitted at every frame and carried to the nearest side girder outside the main engine seating;

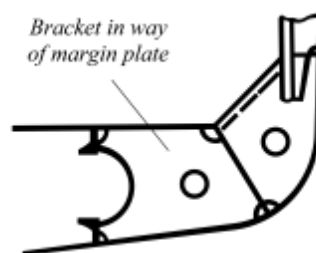

Fig. 2.4.2.5.2

.3 irrespective of the requirements of **2.4.2.5.1** and **2.4.2.5.2**, plate floors shall be fitted:

under pillars and ends of longitudinal partial bulkheads; under bearers and boiler bearer ends;

under transverse bulkheads and sloping plates of low trapezoidal stools of corrugated bulkheads;

under bracket toes of deep tank bulkhead stiffeners in transversely framed double bottom;

under block bearing seatings. In the above cases, the floors need not be fitted throughout the ship's breadth.

Partial floors may be fitted and carried to the side girder nearest to the structure being stiffened.

2.4.2.6 Arrangement of stiffeners on centre girder and duct keel, side girders and floors shall satisfy the following requirements:

.1 stiffeners shall be provided where transverse system of framing is adopted and plate floors are more than 900 mm in depth. The spacing of stiffeners shall not exceed $1,5$ m. The spacing of stiffeners of lightened floors shall not exceed $2,2$ m.

If longitudinal system of framing is adopted, the stiffeners on plate floors shall be fitted in line with bottom and inner bottom longitudinals. The stiffeners shall be carried to the longitudinals, and either welded thereto or attached by the brackets.

The stiffeners shall be fitted under the pillars, at bracket toes of end stiffeners of longitudinal partial bulkheads, etc;

.2 watertight floors shall be fitted with vertical stiffeners spaced not more than 0,9 m apart.

2.4.2.7 Holes (manholes) shall satisfy the following requirements:

.1 an adequate number of holes (manholes) shall be provided in the inner bottom plating, side girders and floors for access to all portions of double bottom.

The size of the holes, including lightening holes, shall satisfy the requirements of standards or other normative documents recognized by the Register. Air and drain holes, cut-outs for the passage of welded joints, refer to **1.7.5.12**);

.2 the holes in centre girder, side girders and floors shall have a smooth rounded shape. The minimum allowable height of the plate adjoining bottom shell plating or inner bottom plating is indicated in Table 2.4.2.7.2.

Besides, the minimum height of the plate in way of the hole shall not be less than 1 /8 of the length of the hole.

The plate height indicated in Table 2.4.2.7.2 may be reduced if suitable stiffening is provided.

Besides, lightened side girder and floor plates shall satisfy the requirements of 2.4.4.5.5, and if the plate height h_0 , in mm, exceeds $25s\sqrt{\eta}$, the free edge of the plate shall be stiffened.

Where: s – lightened side girder or floor height, in mm;

for η – refer to **1.1.4.3**;

Table 2.4.2.7.2

Member	Minimum allowable plate height (in parts of member height)
Centre girder	0,3
Side girders	0,25
Lightened side girders	0,15
Floors:	
plate	0,25
lightened	0,2

.3 the distance between the edges of adjacent openings in centre girder, side girders and plate floors shall not be less than half the length of the largest opening.

The distance of the edges of openings in the floors from longitudinal bulkheads, centre girder, side girders, inclined margin plate and inner edges of hopper side tanks shall not be less than half the centre girder depth in this region.

The distance of the edge of opening in a lightened floor from the side girder shall not be less than one-quarter of centre girder depth.

In exceptional cases, deviation from the above requirements is permitted;

.4 one or more consecutive openings may be permitted in a lightened side girder web between adjacent floors or in a lightened floor web between adjacent side girders. In the latter case, vertical stiffeners shall be fitted between openings. The length of one opening shall not exceed 1,2 times the accepted depth of centre girder or 0,7 times the distance between floors (side girders) or between a floor (side girder) and vertical stiffener, whichever is less (refer to Fig. 2.4.2.5.1-2). The distance of the edges of openings in lightened side girders and floors from each other shall not be less than half the centre girder depth in this regio;

.5 normally, openings are not permitted:

in centre girder over a length of 0,75L from the fore perpendicular;

in centre girder and side girders (lightened side girders) under pillars and in sections adjoining transverse bulkheads (between the bulkhead and extreme floor for double bottom with transverse framing and on a length equal to the depth of double bottom with longitudinal framing);

in floors under pillars and in way of partial longitudinal bulkheads;

in floors at the toes of brackets transversely supporting main machinery seatings;

in floors between the side (inner side) and the nearest lightened side girder, provided the spacing of floors is increased in accordance with **2.4.2.5.2**.

In exceptional cases, openings are permitted in the above members provided the webs in way of the openings are suitably stiffened;

.6 circular lightening openings are permitted for brackets, having a diameter not greater than 1/3 of the width or height of the bracket, whichever is less.

2.4.2.8 Where double skin side construction is provided, the inner bottom plating shall extend through the inner skin as far as the shell plating.

A side girder shall be fitted in line with the inner skin. Festoon plates may be fitted in lieu of the inner bottom plating inside the double skin side or additional side girder in line with the inner skin.

2.4.2.9 Connections of bottom and inner bottom longitudinals to watertight floors shall be such that the effective sectional area of these members is maintained.

2.4.3 Double bottom loads.

2.4.3.1 The external pressure on double bottom structures is determined by Formula 2.2.3-1.

For design ballast condition, the value of z_i according to 1.3.2.1-2 shall be counted from the design ballast waterline.

2.4.3.2 Double bottom loads from inside:

.1 design pressure on the double bottom from general cargo is determined according to **1.3.4.1**;

.2 design pressure on the double bottom from liquid cargo or ballast is determined according to **1.3.4.2**;

.3 design pressure on the double bottom from bulk cargo is determined according to **1.3.4.3**;

.4 test loads

$$p = 7,5h_p, \quad (2.4.3.2.4)$$

where h_p – vertical distance, in m, from inner bottom plating to the top of air pipe;

.5 loads due to the emergency flooding of double bottom compartments:

$$p = 10,5 (d - h), \quad (2.4.3.2.5)$$

where h - actual depth of double bottom, in m.

2.4.3.3 The total design pressure on the double bottom is defined as a difference between the external pressure p and the cargo (ballast) pressure from inside p_c .

In this case, the value of p_c is defined as the smallest value of counterpressures determined from **2.4.3.2.1–**

2.4.3.2.3 with $p > p_c$, and as the greatest of the above values with $p < p_c$.

If a hold may be empty during service, the external pressure p shall be taken as the design pressure.

2.4.4 Scantlings of double bottom members.

2.4.4.1 At centre girder, the depth of double bottom h , m, shall not be less than:

$$h = (L - 40) / 570 + 0,04 \cdot B + 3,5 \cdot d / L, \quad (2.4.4.1)$$

but not less than 0,65 m, unless a greater value is indicated in other sections of these Rules and the Rules for the Prevention of Pollution from Ships.

2.4.4.2 The centre girder and side girders shall satisfy the following requirements:

.1 the thickness, in mm, of centre girder (duct keel) shall not be less than

$$s = (\alpha_k \cdot h^2 \cdot \sqrt{\eta} / h_\phi) + \Delta s, \quad (2.4.4.2.1)$$

where: h – height of centre girder, in m, required by **2.4.4.1**;

h_ϕ – actual height of centre girder, in m;

for η – refer to **1.1.4.3**;

for Δs – refer to **1.1.5.1**;

$\alpha_k = 0,03L + 8,3$, but not greater than 11,2.

In any case, the thickness of centre girder shall be 1 mm greater than that of a plate floor.

The thickness of side girders shall not be less than that of plate floors;

.2 the buckling strength of centre girder web and of side girders, as well as of longitudinal stiffeners fitted along them shall be ensured in accordance with **1.6.5**;

.3 at ends within $0,1L$ from the fore and after perpendiculars, the centre girder web thickness may be 10 % less than that in the midship region, as determined for steel used at ends, but not less than the minimum thickness stipulated under **2.4.4.9**.

The thickness of side plates of the duct keel shall not be less than 0,9 of that required for the centre girder in this region;

.4 the thickness of watertight sections of centre girder and side girders shall not be less than determined by Formula (1.6.4.4) taking:

p – as determined by Formulae (1.3.4.2.1-4) and (1.3.4.2.1-5) for the mid-depth of centre girder (side girder), whichever is the greater (where no safety valve is fitted

$p_v = 0$);

$m = 15,8$;

if the centre girder (side girder) is stiffened with vertical brackets or stiffeners:

$k_\sigma = 0,6k_b \leq 0,75$ for $L \geq 65\text{m}$;

$k_\sigma = 0,75$ for $L = 12\text{m}$.

For $12 < L < 65\text{m}$ k_σ shall be determined by linear interpolation taking $k_\sigma = 0,68$ at $L = 65\text{m}$;

if the centre girder (side girder) is stiffened with horizontal stiffeners, in the midship region:

$k_\sigma = 0,75$;

at the ends of the ship within $0,1L$ from the fore or after perpendicular:

$k_\sigma = 0,85$.

For regions between the midship region and above portions of ship's ends, k_σ shall be determined by linear interpolation;

k_b shall be determined by Formula (2.2.4.1).

The thickness of the watertight sections of centre girder and side girders need not be greater than that of adjacent shell plating.

2.4.4.3 Floors shall satisfy the following requirements:

.1 the thickness, in mm, of floors shall not be less than

$$s = \alpha \cdot k \cdot a \cdot \sqrt{\eta} + \Delta s, \quad (2.4.4.3.1)$$

where: $\alpha = 0,12L - 1,1$, but not greater than 6,5 for transversely framed double bottom;

$\alpha = 0,023L + 5,8$ for longitudinally framed double bottom;

$k = k_1 \cdot k_2$;

k_1, k_2 – coefficients given in Tables 2.4.4.3-1 and 2.4.4.3-2 respectively;

a – spacing, in m, of stiffeners, but not greater than the actual depth of double bottom;

for η – refer to **1.1.4.3**;

for Δs – refer to **1.1.5.1**;

Table 2.4.4.3-1 Coefficient k_1

Framing system	a_f/a				
	1	2	3	4	5
Transverse	1	1,15	1,20	1,25	1,30
Longitudinal	-	1,25	1,45	1,65	1,85

Symbols:
 a_f – distance, in m, between plate floors;
 a – spacing, in m.

Table 2.4.4.3-2 Coefficient k_2

Framing system	Кількість стрингерів на один борт			
	0	1	2	3 і більше
Transverse	1	0,97	0,63	0,88
Longitudinal	1	0,93	0,86	0,80

.2 the floors shall be stiffened in accordance with **1.7.3.2**.

Between the fore peak bulkhead and $0,25L$ from the forward perpendicular, in the engine room and peaks, and in the holds of ships which may happen to be aground due to ebb-tide or from which cargo is regularly discharged by grabs, the thickness of plate floors s_{min} , in mm, shall not be less than:

for transverse framing system

$$s_{min} = 0,035L + 5\text{mm}; \quad (2.4.4.3.2-1)$$

for longitudinal framing system

$$s_{min} = 0,035L + 6\text{mm}; \quad (2.4.4.3.2-2)$$

.3 the thickness of watertight floors shall not be less than determined by Formula (1.6.4.4) taking:

p – as determined by Formulae (1.3.4.2.1-4) and (1.3.4.2.1-5) for the middepth of the floor, whichever is the greater in the absence of a safety valve:

$$p_v = 0;$$

$$m = 15,8;$$

$$k_\sigma = 0,85.$$

In any case, the thickness of watertight floors shall not be less than that required for plate floors in this region.

2.4.4.4 Inner bottom plating and margin plate shall satisfy the following requirements:

.1 the thickness of inner bottom plating, including margin plate, shall not be less than determined by Formula (1.6.4.4) taking:

$$m = 22,4;$$

p – maximum design pressure as stipulated under **2.4.3.2**;

$k_\sigma = 0,6k_b \leq 0,8$ in the midship region for $L \geq 65$ m and transverse framing system;

$k_\sigma = 0,8$ in the midship region for $L = 12$ m and transverse framing system.

For $12 < L < 65$ m k_σ , is determined by linear interpolation taking $k_\sigma = 0,7$ for $L = 65$ m,

$k_\sigma = 0,8$ in the midship region for longitudinal framing system;

$k_\sigma = 0,9$ at the ends of the ship within $0,1L$ from the fore or after perpendicular.

For regions between the midship region and the above portions of ship's ends, k_σ shall be determined by linear interpolation;

k_b shall be determined by Formula (2.2.4.1);

.2 in any case, the thickness of inner bottom plating s_{min} , in mm, shall not be less than:

$$s_{min} = (0,05L + 3,8)\sqrt{\eta}, \quad \text{for } L < 80\text{m}, \quad (2.4.4.4.2-1)$$

$$s_{min} = (0,035L + 5)\sqrt{\eta}, \quad \text{for } L \geq 80\text{m}, \quad (2.4.4.4.2-2)$$

where: η – as stated in Table 1.1.4.3.

For $L > 260$ m, L shall be taken equal to 260 m.

Where the adopted spacing is less than the standard one (refer to **1.1.3**) for ships of unrestricted service and restricted area of navigation **R1** and **A-R1**, the minimum thickness of inner-bottom plating may be reduced

in proportion to the ratio of adopted spacing to the standard spacing, but not more than by 10 %. In any case, the minimum thickness shall not be less than 5,5 mm.

The thickness of inner bottom plating in holds into which water ballast may be taken, as well as in the cargo (ballast) tanks of tankers shall not be less than stipulated under **3.5.4**.

In the engine room and holds under cargo hatches where no wood sheathing is provided, s_{\min} shall be increased by 2 mm.

In holds where no wood sheathing is provided and cargo is discharged by grabs, s_{\min} shall be increased by 4 mm.

.3 in the midship region of ships of 65 m and greater in length, the buckling strength of inner bottom plating and margin plate shall be ensured in accordance with **1.6.5**.

2.4.4.5 Primary members of bottom and inner bottom shall satisfy the following requirements:

.1 the section modulus of bottom and inner bottom longitudinals, as well as of the bottom and reverse frames of bracket floors and duct keel shall not be less than stipulated under **1.6.4.1** taking:

p – design pressure, in kPa, determined for bottom longitudinals and the bottom frames of bracket floors and duct keel in accordance with **2.4.3.1**, and for inner bottom longitudinals and the reverse frames of bracket floors and duct keel, in accordance with **2.4.3.2**;

$$m = 12;$$

l – = design span, in m, of longitudinal, defined as the spacing of floors for bottom and inner bottom longitudinals, as the distance between bracket toes or between a bracket toe and side girder for the bottom and reverse frames of bracket floors, as the spacing of webs for duct keel;

for bottom longitudinal:

$$k_{\sigma} = 0,45k_b \leq 0,65 \text{ in the midship region};$$

$$k_{\sigma} = 0,65 \text{ at the ends of the ship within } 0,1L \text{ from the fore or after perpendicular.}$$

For regions between the midship region and the above portions of ship's ends, k_{σ} shall be determined by linear interpolation;

for inner bottom longitudinals:

$$k_{\sigma} = 0,6k_b \leq 0,75 \text{ in the midship region};$$

$$k_{\sigma} = 0,75 \text{ at the ends of the ship within } 0,1L \text{ from the fore or after perpendicular.}$$

For regions between the midship region and the above portions of ship's ends, k_{σ} shall be determined by linear interpolation;

for bottom frames of bracket floors and duct keel:

$$k_{\sigma} = 0,65;$$

for reverse frames of bracket floors and duct keel:

$$k_{\sigma} = 0,75;$$

k_b shall be determined by Formula (2.2.4.1);

.2 if intermediate struts are fitted at midspan between bottom and inner bottom longitudinals, the section modulus of such longitudinals may be reduced by 35%;

.3 if the ratio of the span of a bottom or inner bottom longitudinal to its depth is less than 10, the sectional area of the longitudinal web shall not be less than determined by Formula (1.6.4.3-1) taking $N_{\max} = 0,5pal$ (p , l – design pressure and design span of longitudinal as stipulated under **2.4.4.5.1**), $k_{\tau} = k_{\sigma}$, where k_{σ} is as determined from **2.4.4.5.1** with $k_b = 1,25$;

.4 in the midship region of ships of 65 m in length and above, the buckling strength of bottom and inner bottom longitudinals shall be ensured in accordance with **1.6.5**;

.5 at the centre of openings in lightened side girders and floors, the section modulus of the plate adjoining the shell plating or inner bottom plating shall comply with the requirements of **2.4.4.5.1** for bottom and inner bottom longitudinals and transverses respectively. In this case, the design span l shall be taken equal to the greatest opening length minus its rounding-off radius. The plate section shall include the effective flange of shell plating (inner bottom plating), as described under **1.6.3.2** and **1.6.3.3**, as well as the flange or horizontal stiffener of the free edge of the plate, if these are fitted.

2.4.4.6 The stiffeners on the watertight sections of centre girder (duct keel), side girders and floors shall satisfy the following requirements:

.1 the section modulus of vertical stiffeners on the watertight sections of centre girder (duct keel), side girders and floors shall not be less than stipulated under **1.6.4.1** taking:

p – as determined by Formula (1.3.4.2.1-5) for mid-height of vertical stiffener;

l – span, in m, of stiffener, defined as the spacing of longitudinals to which the stiffener is welded or as double bottom depth if the stiffener is not in line with bottom or inner bottom longitudinals;

$m = 8$ and 10 – for stiffeners sniped at ends and welded to the bottom and inner bottom longitudinals respectively;

$k_{\sigma} = 0,75$;

.2 the section modulus of horizontal stiffeners on the centre girder (duct keel) and side girders shall not be less than stipulated under **1.6.4.1** taking:

p – as determined by Formula (1.3.4.2.1-5) for the level of the horizontal stiffener considered;

l – distance, in m, between floors or between floors and brackets (refer to **2.4.2.2**);

$m = 12$;

$k_{\sigma} = 0,5k_b \leq 0,75$ in the midship region;

$k_{\sigma} = 0,75$ at the ends of the ship within $0,1L$ from the fore or after perpendicular.

For regions between the midship region and the above portions of ship's ends, k_{σ} shall be determined by linear interpolation;

k_b shall be determined by Formula (2.2.4.1);

.3 in the midship region of ships of unrestricted service **A**, and of restricted areas of navigation **R1**, **A-R1** and **R2**, **A-R2** 65 m and greater in length, as well as of ships of restricted areas of navigation **R2-S**, **R2-RS**, **A-R2-S**, **A-R2-RS**, **B-R3-S**, **B-R3-RS**, **C-R3-S**, **C-R3-RS**, **R3-S**, **R3-RS**, **R3**, **R3-IN**, **D-R3-S**, **D-R3-RS** 60 m and greater in length, the buckling strength of horizontal stiffeners on the centre girder (duct keel) and side girders shall be ensured in accordance with **1.6.5**.

2.4.4.7 The intermediate struts between bottom and inner bottom longitudinals, as well as between bottom and reverse frames of bracket floors shall satisfy the following requirements:

.1 the sectional area f , cm², of intermediate struts shall not be less than

$$f = [5pal / (k_{\sigma}\sigma_n)] + 0,1h\Delta s, \quad (2.4.4.7.1)$$

where p – design pressure, in kPa, defined as the greater of the values of p or p_c according to **2.4.3.1** or **2.4.3.2**, whichever is the greater;

l – design span, in m, of stiffened longitudinals;

$k_{\sigma} = 0,5$;

h – height, in cm, of the strut cross section;

for Δs – refer to **1.1.5.1**;

.2 the inertia moment i , in cm⁴, of intermediate struts shall not be less than:

$$i = 0,01 f l^2 \sigma_n, \quad (2.4.4.7.2)$$

where f – sectional area of intermediate struts as given in **2.4.4.7.1**;

l – length, in m, of intermediate strut.

2.4.4.8 The thickness of brackets of centre girder (duct keel) and margin plate, as well as of the brackets of bracket floors and the brackets connecting bottom and inner bottom longitudinals to watertight floors, if the longitudinals are cut at the floors, shall not be less than the thickness of plate floors adopted in this region.

In way of centre girder and margin plate, the thickness of brackets fitted in line with the bracket floor shall not be less than 0,75 of the centre girder depth. The free edges of brackets shall be provided with flanges or face plates. The side girder fitted in line with the bracket floor shall be provided with a vertical stiffener whose profile shall be selected in the same way as that of the reverse frame of the floor.

The arm length of brackets connecting longitudinals on the bottom and inner bottom plating to watertight floors shall not be less than 2,5 times the bottom longitudinal depth (refer to Fig. 2.4.4.8).

The scantlings of knees by which bottom and reverse frames of the duct keel are secured shall be determined in accordance with 1.7.2.2.

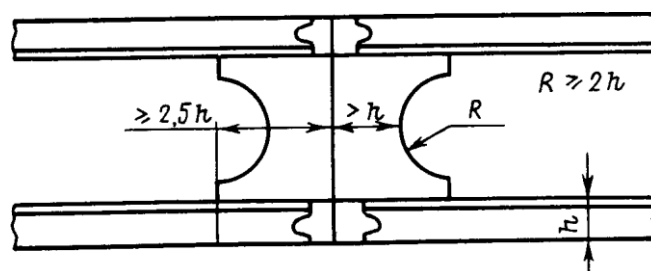

Fig.2.4.4.8

2.4.4.9 Structural members inside the double bottom shall have a thickness s_{min} , in mm, not less than:

$$s_{min} = 0,045L + 3,9 \text{ mm for } L < 80 \text{ m,} \quad (2.4.4.9-1)$$

$$s_{min} = 0,025L + 5,5 \text{ mm for } L \geq 80 \text{ m.} \quad (2.4.4.9-2)$$

Where $L > 250$ m, L shall be taken equal to 250 m.

For centre girder, s_{min} shall be increased by 1,5 mm.

2.4.4.10 In way of holds designed for the carriage of heavy cargoes, the strength of double bottom structure shall be verified by the calculation of the bottom grillage strength using design loads stated in 2.4.3, as required by 3.3.4.1.1.

2.4.5 5 Special requirements.

2.4.5.1 Partial double bottom and stiffening in way of variable double bottom depth shall satisfy the following requirements:

.1 where the double bottom terminates, gradual transition from longitudinal members of double bottom to those beyond it shall be ensured.

The inner bottom plating shall be gradually tapered (on a length of at least three frame spaces) into the face plates of centre girder and side girders of single bottom. In way of the double bottom boundary, the width of these face plates shall be not less than half the distance between adjacent side girders.

The margin plate shall extend beyond the double bottom as a bracket with the height equal to the margin plate width and the length equal to at least three frame spaces, with a face plate or flange along its free edge;

.2 where the double bottom depth changes in the form of a knuckle, one end of the knuckle shall be in way of a transverse bulkhead and the other, on the fplate floor. However, both the knuckles may be arranged on plate floors; in this case the strength of the structure shall be verified by calculation;

.3 where the double bottom depth changes in the form of a step, the latter shall normally be arranged on a transverse bulkhead.

At the step, the inner bottom plating of the lower section should extend for a length of three frame spaces when $L \geq 80$ m and for two frame spaces when $L < 80$ m. Forward (or aft) of the end of the extension the general requirements for partial double bottom shall be complied with.

If the step is arranged beyond $0,5L$ amidships or, if the height of the step is less than 660 mm, the extension may be reduced;

.4 continuity and reduction of stress concentrations shall be ensured in way of the step where a variation of the depth of centre girder, side girders, margin plate and inner bottom longitudinals takes place (if longitudinal system of framing is adopted).

2.4.5.2 Bilge wells, sea chests and ice boxes shall satisfy the following requirements:

.1 in cargo ships, the bilge wells shall, as far as practicable, satisfy the requirements of 1.1.6.5.3 or 1.1.6.6.3.

The capacity of bilge wells is specified in Part VIII "Systems and Piping".

The thickness of the walls and bottom plates of a bilge well shall exceed that of watertight floors by not less than 2 mm;

.2 the thickness of the floors, side girders and inner bottom plating forming the walls of sea chests shall be 2 mm greater than that required by 2.4.4.2 ÷ 2.4.4.4.

In any case, the thickness of sea chest and ice box walls shall be not less than that required by 2.2.4.1 for the shell plating in the region under consideration.

2.4.5.3 When oil fuel tanks are arranged in the double bottom, the manholes in the tank tops arranged within the engine and boiler rooms for access to the tanks shall be provided with coamings not less than 0,1 m in height, besides the general provisions for the arrangement of fuel oil tanks.

2.4.5.4 Where the bed plate of main engine and the thrust block are seated directly on the inner bottom plating, insert plates having a thickness not less than stipulated under **2.11.3.1** shall be welded to the plating under the supporting parts of bed plate and thrust block. The size of welded inserts shall be such as to ensure an adequate arrangement of supports and the attachment of machinery, and shall in any case be not less than that of the supporting parts of bed plate. Where the engine bed plate and thrust block are fitted on the inner bottom plating, two girders, or one girder and a half-height girder shall be provided in way of their arrangement along each welded insert plate. The upper part of the girder webs shall have the same thickness as the welded insert for at least 0,2 of the girder depth, or alternatively, the thickness of the webs throughout their depth shall be as required by **2.11.3** for the vertical plates of seatings.

Between the girders, a horizontal stiffener of the size required in the foregoing for the upper part of girder webs shall be fitted, account being taken of the holes for the holddown bolts of the bed plate.

Only one side girder may be fitted under the welded insert plate for small power engines.

2.4.5.5 The plating of the recess under the engine crankcase, as well as the side girders and floors by which it is confined, shall have a thickness 2 mm greater than that of the inner bottom plating in this region.

The minimum distance from the recess plating to the bottom shell plating shall not be less than 460 mm.

2.5 SIDE FRAMING

2.5.1 General and definitions.

2.5.1.1 Requirements are given in this Chapter for side frames, web frames (side transverses), side longitudinals, side stringers, cross ties connecting side transverses to vertical webs on longitudinal bulkheads in tankers, as well as for specific structures of double skin side.

2.5.1.2 By the double skin side construction, a side structure is meant which consists of watertight side shell plating and inner skin, both either strengthened with frames and longitudinals or not, and connected with plate structures perpendicular thereto: vertical (diaphragms) and/or horizontal (platforms). If no diaphragms or platforms are fitted, the inner skin together with framing shall be considered as longitudinal bulkhead and shall comply with the requirements of **2.7**.

2.5.2 Construction.

2.5.2.1 When the ship's side is framed transversely, side stringers may be provided. In tankers with two or more longitudinal bulkheads, fitting of cross ties is recommended between the side stringers and horizontal girders of longitudinal bulkheads.

Web frames may be fitted if the ship's side is framed transversely, and they shall be fitted, if the ship's side is framed longitudinally.

They shall be fitted in line with plate floors, as well as with deep beams, if any.

In tankers with two or more longitudinal bulkheads, fitting of cross ties is recommended between side transverses and vertical webs of longitudinal bulkhead.

2.5.2.2 Structures of double skin side shall satisfy the following requirements:

.1 if the same framing system is adopted for side shell and inner skin, fitting of frames or longitudinals of both side shell and inner skin in line with each other is recommended. In this case, cross ties may be fitted between the frames or longitudinals of the side shell and inner skin, which shall be arranged at midspan of relevant members ;

.2 diaphragms or platforms shall be stiffened in accordance with **1.7.3.2**. In this case, the shorter side, in mm, of panel of the diaphragm or platform being stiffened shall not exceed $100s\sqrt{\eta}$, where s is the thickness, in mm, of the diaphragm or platform;

For η – refer to **1.1.4.3**;

.3 an appropriate number of openings (manholes) shall be provided in the diaphragms and platforms for access to all the structures of double skin side.

The total breadth of openings in a diaphragm or platform section shall not exceed 0,6 of the double skin side breadth. The edges of openings in diaphragms and platforms, arranged within 1/4 of the span from their supports, shall be reinforced with collars or stiffeners.

The distance between the edges of adjacent openings shall not be less than the length of the openings.

Normally, openings are not permitted, with the exception of air and drain holes:

in platforms on a length not less than three frame spaces or 1,5 times the double skin side breadth, whichever is less, from transverse bulkheads or partial bulkheads, which serve as platform supports;

in diaphragms on a length not less than 1,5 times the double skin side breadth from deck plating and/or double bottom, which serve as diaphragm supports.

2.5.2.3 In the engine room, the side framing shall be strengthened by fitting of web frames and side stringers.

The web frames shall be fitted not more than 5 standard spacings or 3 m apart, whichever is the greater.

The web frames shall be arranged taking into account the location of main engine, i.e. they shall be fitted at the extremities of the engine at least. In the engine room, the web frames shall be carried to the nearest continuous platform.

Deep beams shall be fitted in line with web frames.

In the engine room, the side stringers shall be fitted so that the vertical distance between them, as well as between a side stringer and deck or tank top (upper edge of floor) at side does not exceed 2,5 m.

2.5.3 Side loads.

2.5.3.1 The design pressure on the side shell shall be determined in accordance with **2.2.3**.

In way of tanks, the pressure determined in accordance with **1.3.4.2** shall additionally be taken into consideration.

2.5.3.2 The design pressure on double skin side structures shall be determined as follows:

.1 the design pressure on the inner skin and framing shall be determined in accordance with **1.3.4.2** or **1.3.4.3** depending on the kind of cargo carried and on whether the double side space is used as tank space, but shall not be less than the design pressure on watertight bulkhead structures, as stipulated under **2.7.3.1**;

.2 the scantlings of cross sections of diaphragms and platforms are determined using the design pressure specified in **2.2.3**;

.3 the design pressure on the watertight sections of diaphragms and platforms bounding the tanks in the double side space shall be determined in accordance with **1.3.4.2**.

2.5.4 Member scantlings of side structures.

2.5.4.1 If transverse system of framing is adopted, the section modulus of hold frames in dry cargo ships and of side frames in tankers shall not be less than determined from **1.6.4.1** and **1.6.4.2**. taking:

p – as defined in **2.5.3**; the value of p for the side shell shall not be less than

$$p_{\min} = 10z + 0,3L + 1, \quad \text{for } L < 60 \text{ m}; \quad (2.5.4.1-1)$$

$$p_{\min} = 10z + 0,15L + 10, \quad \text{for } L \geq 60 \text{ m}; \quad (2.5.4.1-1)$$

where: z – distance, in m, from the mid-span of the frame to the summer load waterline;

l – in m, between adjacent supports, as measured in accordance with **1.6.3.1**; unless expressly provided otherwise, the supports of a frame are bottom, deck or platform, side stringers;

$m = 12$ for single skin side construction when determining the section modulus of the supporting section of the frame taking into consideration the bracket, if any, included in the section, as well as for frames of the side shell and inner skin forming double skin side construction;

$m = 18$ for single skin side construction when determining the section modulus in the frame span;

$k_{\sigma} = 0,65$ for frames of the side shell;

$k_{\sigma} = 0,75$ for frames of the inner skin.

For ships of restricted service p_{\min} may be reduced by multiplying by a factor φ_r , determined in accordance with Table 1.3.1.5.

2.5.4.2 The section modulus of tween deck frames shall not be less than determined according to **1.6.4.1** taking:

p – as defined in **2.5.3**;

l – average spacing of web frames or diaphragms, in m determined in accordance with **1.6.3.1**; supporting section of the frame are decks and platforms;

$m = 10$ for single skin side construction;

$m = 12$ for frames of the side shell and inner skin within the double-side construction;

$k_{\sigma} = 0,65$ for frames of the side shell;

$k_{\sigma} = 0,75$ for frames of the inner skin.

The above applies in case the lower end of 'tween deck frame is not stiffened by a bracket. If the lower end of the frame is stiffened by a bracket of a height not less than $0,11$ and the section modulus of the frame in way of deck is not less than $1,75$ of the section modulus determined above, taking the bracket into consideration, the section modulus of 'tween deck frame may be reduced by 30% .

2.5.4.3 The section modulus of side longitudinals of all ships shall not be less than determined according to **1.6.4.1** taking:

p – as defined in **2.5.3**;

a – spacing of longitudinals, in m;

l – average spacing of web frames or diaphragms, in m;

$m = 12$;

for side shell:

$k_{\sigma} = 0,65$ within $(0,4 \div 0,5)D$ from the base line.

For regions below $0,4D$ from the base line, k_{σ} shall be determined by linear interpolation between k_{σ} for bottom longitudinals in accordance with **2.4.4.5.1** and k_{σ} within $(0,4 \div 0,5)D$ from the base line.

For regions above $0,5D$ from the base line k_{σ} shall be determined by linear interpolation between k_{σ} s for strength deck longitudinals in accordance with **2.6.4.2** and k_{σ} within $(0,4 \div 0,5)D$ from the base line.

For the inner skin, k_{σ} shall be determined as in the case of horizontal stiffeners of longitudinal bulkheads in tankers in accordance with **2.7.4.2**.

The buckling strength of three upper and three lower longitudinals in the midship region of ships 65 m and greater in length shall be ensured in accordance with **1.6.5**.

2.5.4.4 In a transversely framed side, the section modulus of side stringers shall not be less than stipulated under **1.6.4.1** taking:

$k_{\sigma} = 0,65$ is determined in the same way as for side shell longitudinals mentioned under **2.5.4.3**;

p – as defined in **2.5.3.1**;

l – spacing, in m, of web frames and where these are not fitted, between transverse bulkheads, including end brackets;

a – spacing, in m, of side stringers;

$m = 18$ without cross ties;

$m = 27,5$ with cross ties.

The cross-sectional area, in cm^2 , of a side stringer web shall not be less than determined according to **1.6.4.3** taking:

$N_{\text{max}} = npal$;

$n = 0,5$ without cross ties;

$n = 0,4$ with one cross tie;

$n = 0,375$ with two cross ties;

$n = 0,35$ with three cross ties;

$k_{\tau} = 0,65$.

If web frames are fitted, the scantlings of side stringer section may be determined on the basis of the calculation of the side grillage using beam models.

The design loads shall be determined in accordance with **2.5.3.1**, permissible stress factors shall be selected in accordance with this paragraph.

Where cross ties are fitted, the calculation shall consider the interaction between side grillage and grillage of the longitudinal bulkhead being connected with the cross ties.

2.5.4.5 The section modulus of web frames (side transverses) fitted in the holds and 'tween decks of dry cargo ships, as well as in the tanks of tankers, shall not be less than stipulated under **1.6.4.1** and **1.6.4.2** taking:

p – as defined in **2.5.3.1**;

l – distance, in m, from the upper edge of a single bottom floor or from inner bottom plating to the lower edge of a deep beam;

a – spacing of web frames, in m;

$m = 10$ for 'tween deck frames;

$m = 11$ for holds and tanks without cross ties;

$m = 18$ with one or two cross ties;

$m = 27,5$ with three cross ties;

$k_{\sigma} = 0,65$.

The cross-sectional area, in cm^2 , of a side transverse (web frame) web, excluding openings, shall not be less than stipulated under **1.6.4.3** taking:

$$N_{\max} = npal;$$

$$n = 0,5 \text{ without cross ties;}$$

$$n = 0,375 \text{ with one cross tie;}$$

$$n = 0,35 \text{ with two or more cross ties;}$$

$$k_{\tau} = 0,65.$$

When the side is transversely framed, the scantlings of web frames may be determined on the basis of the side grillage calculation in accordance with the requirements of **2.5.4.4**.

In this case, the permissible stress factors shall be selected in accordance with the requirements of this paragraph.

In single-deck ships, the depth of web frame (side transverse) webs may be taken variable over the ship's depth with reducing at the top end and increasing at the bottom end. Variation of web depth shall not exceed 10 % of its mean value.

For stiffening of web frames (side transverses), refer to **1.7.3**.

2.5.4.6 The sectional area f , in cm^2 , of a cross tie fitted between deep members of side framing and of longitudinal bulkhead shall not be less than

$$f = (10kpaai/\sigma_{cr}) + 0,05\sum h_i\Delta s, \quad (2.5.4.6)$$

where: p – design pressure, in kPa, at mid-length of a cross tie, as determined from **2.2.3** or **2.7.3.2**, whichever is the greater;

a – spacing of web frames connected with cross ties, in m;

a_i – mean depth, in m, of side area supported by a cross tie;

$\sum h_i$ – perimeter of cross section, in cm, of a cross tie;

$k = 2,5$ – buckling strength margin;

σ_{cr} – critical stresses in accordance with **1.6.5.3** corresponding to the Euler stresses, in MPa, as determined by the formula:

$$\sigma_e = 206i/(l^2),$$

where: i – minimum moment of inertia, in cm^4 , of a cross tie;

l – cross tie length, in m, as measured between the inner edges of deep members of side framing and of longitudinal bulkhead;

f – as determined by Formula (2.5.4.6).

2.5.4.7 The side framing of the engine room and tanks shall satisfy the following requirements:

.1 scantlings of main frames in the engine room shall be determined in accordance with **2.5.4.1** taking

l – span measured between side stringers or between the lower side stringer and inner bottom plating (upper edge of floor), or between the upper side stringer and the lower edge of beam.

The scantlings of longitudinals shall be determined in accordance with **2.5.4.3**.

The scantlings of web frames (side transverses) shall be determined in accordance with **2.5.4.5** taking:

l – span measured between inner bottom plating (upper edge of floor) and the lower edge of deep beam;

.2 in the engine room of ships less than 30 m in length, the web frames and side stringers required by **2.5.2.3** may be omitted on condition that the main frame has a section modulus W , in cm^3 , not less than:

$$W = 1,8 W_1, \quad (2.5.4.7.2)$$

where: W_1 – section modulus of main frame, as stipulated under **2.5.4.7.1**;

.3 in way of the ballast and fuel oil tanks of dry cargo ships 30 m and greater in length, the scantlings of side framing shall satisfy the requirements of **2.5.4.1**, **2.5.4.3**, **2.5.4.5** for side framing in way of tanks in tankers.

If transverse system of framing is adopted, the section modulus of side stringers shall not be less than determined according to **1.6.4.1** and **1.6.4.2** taking:

$$m = 10;$$

$$k_{\sigma} = 0,65.$$

In all other respects, the requirements of **2.5.4.4** shall be complied with;

.4 in the engine room, the web frames shall have a depth not less than 0,1 of the span, and a web thickness not less than 0,01 of the web depth plus 3,5 mm;

.5 in the engine room, the web depth of a side stringer shall be equal to that of a web frame.

The web thickness of a side stringer may be 1 mm less than that of a web frame.

The side stringer face plate thickness shall be equal to the face plate thickness of a web frame.

2.5.4.8 The diaphragms and platforms of the double skin side shall satisfy the following requirements:

.1 the section moduli and cross-sectional areas of diaphragms and platforms shall satisfy the requirements for the section moduli and cross-sectional areas of side stringer webs, as specified in **2.5.4.4**, and of web frames, as specified in **2.5.4.5**, using the design pressure determined in accordance with **2.5.3.2.2**.

In any case, the thickness, in mm, of diaphragm and platform shall not be less than

$$s_{\min} = 0,018L + 6,2; \quad (2.5.4.8.1)$$

.2 the stiffeners of diaphragms and platforms shall satisfy the requirements of **1.7.3.2.2**;

.3 the platforms in the midship region and their continuous longitudinal stiffeners, if any, shall comply with the requirements for the buckling strength of longitudinal framing members, as specified in **1.6.5.2**, within 0,25D above the base line and 0,25D below the strength deck;

.4 the thickness of watertight sections of diaphragms and platforms shall not be less than that determined by Formula (**1.6.4.4**) taking:

p – as defined in **2.5.3.2.3**;

$m = 15,8$;

$k_{\sigma} = 0,65$;

.5 the section modulus of stiffeners of the watertight sections of diaphragms and platforms shall not be less than determined from **1.6.4.1** taking:

p – as defined in **2.5.3.2.3**;

l – = span of stiffener, in m, equal to: the diaphragm spacing, for stiffeners parallel to the shell plating; the distance between the inner edges of primary members of side shell and inner skin if the stiffener is welded thereto, for stiffeners perpendicular to the shell plating; the double skin side breadth if the stiffener ends are sniped;

$m = 12$ for continuous stiffeners parallel to the side plating;

$m = 10$ for stiffeners perpendicular to the side plating and welded to primary framing members;

$m = 8$ elsewhere;

$k_{\sigma} = 0,75$.

2.5.4.9 If there are large openings (exceeding 0,7 times the ship's breadth in width) in the deck, stiffening of the diaphragms and frames of the side shell and inner skin may be required in connection with the upper deck pliability, which shall be determined by calculation (refer also to **3.1.4**).

2.5.4.10 The thickness of inner skin shall comply with the requirements for the thickness of longitudinal bulkhead plating in tankers, as specified in **2.7.4.1**, using the design pressure determined in accordance with **2.5.3.2.1**. In any case, this thickness shall not be less than determined by Formula (2.7.4.1-1).

2.5.4.11 The cross ties between frames and longitudinals of side shell and inner skin, as mentioned under **2.5.2.2.1**, shall comply with the requirements for the intermediate struts of double bottom, as mentioned in **2.4.4.7** using the design pressure determined from **2.5.3.1** or **2.5.3.2.1**, whichever is the greater.

If cross ties are fitted, the section modulus of frames complying with **2.5.4.1** and **2.5.4.2**, as well as of longitudinals complying with **2.5.4.3**, may be reduced by 35 %.

2.5.4.12 In the cargo and ballast tanks of tankers, in holds into which water ballast can be taken and in tanks, the thickness of structural members of side framing shall not be less than that required by **3.5.4**.

2.5.5 Special requirements.

2.5.5.1 If transverse system of framing is adopted, efficient connection of lower ends of frames to bottom structures shall be ensured by means of bilge brackets or other structures of equivalent strength.

The bilge brackets shall comply with the following requirements:

.1 the depth of bilge brackets shall not be less than that of the bilge as a whole. The free edge of a bilge bracket shall be flanged or stiffened with a face plate the dimensions of which shall be in compliance with 1.7.2.2.2.

The thickness of a bilge bracket is taken equal to that of plate floors in the hull region under consideration, but it need not exceed the frame web thickness more than 1,5 times.

Holes cut in bilge brackets shall be such that the width of plating outside the hole is nowhere less than 1/3 of the bracket width.

In any case, the size of bilge brackets shall not be less than that required by 1.7.2.2;

.2 the end attachments of a frame to bilge bracket shall be designed so that at no section the section modulus is less than required for a frame;

.3 where an inclined margin plate is fitted in the double bottom, the bilge bracket shall be carried to the inner bottom plating, and its face plate (flange) shall be welded to the plating;

.4 where a horizontal margin plate is fitted in the double bottom or transverse system of framing is adopted in the single bottom, the width of bilge brackets shall be determined proceeding from the condition that their section moduli at the point of connection to the inner bottom plating or upper edge of floor shall be at least twice those of the frame.

The face plate (flange) of a bilge bracket may be welded to either the inner bottom plating or the face plate (flange) of a floor, or it may be sniped at ends. If the face plate (flange) is welded, the floor web shall be stiffened with a vertical stiffener or a bracket at the point of welding, also welded to the inner bottom plating or to the floor face plate (flange).

The depth of a bilge bracket shall not be less than its width;

.5 if longitudinal system of framing is adopted in the single bottom, the bilge bracket shall be carried at least to the bottom longitudinal nearest to the side and shall be welded thereto. The section modulus of the bracket at the section perpendicular to the shell plating where the bracket width is the greatest shall be at least twice the section modulus of the frame.

2.5.5.2 In all the spaces, the upper ends of frames shall be carried to the decks (platforms) with minimum gaps if they are cut at the decks (platforms). The beams of transversely framed decks (platforms) shall be carried to the inner edges of frames with minimum gaps.

The uppermost decks of ships (except for those secured alongside other ships at sea) may be designed with beams carried to the shell plating with minimum gaps, and frames carried to the beams.

The brackets by which the upper ends of frames are attached shall be sized in accordance with the requirements of ram 1.7.2.2.

If the deck is framed longitudinally, the bracket shall be carried at least to the deck longitudinal nearest to the deck and welded to that longitudinal.

2.5.5.3 If the frame is cut at deck, its lower end shall be attached by a bracket complying with the requirements of 1.7.2.2.

The bracket may be omitted if the ends of this frame are welded to the deck plating from above and below, and full penetration is ensured.

2.5.5.4 Side stringers shall be attached to web frames by brackets carried to the web frame face plate and welded thereto.

2.5.5.5 If cross ties are fitted in the wing tanks of tankers, the side transverse and side stringer webs in way of the cross tie attachments shall be provided with stiffeners which shall be an extension of the cross tie face plates. Cross tie attachments to side transverse (side stringer) shall comply with the requirements of 1.7.2.3.

2.5.5.6 Double-side attachment to double-bottom shall comply with 2.4.2.8.

2.6 DECKS AND PLATFORMS

2.6.1 General.

Requirements are given in this Chapter for the deck and platform structures of ships where the width of opening for a single cargo hatch does not exceed 0,7 times the ship's breadth abreast of the opening. Additional requirements for the decks and platforms of ships having greater width of openings and their length exceeding 0,7 times the spacing of centres of transverse deck strips between the openings, as well as for the decks and platforms of ships with twin or triple hatch openings, are specified in 3.1.

Requirements for cantilever beams shall also be found there.

For decks and platforms of ro-ro ships, refer to 3.2.

Requirements for the cargo hatch coamings of bulk carriers are given in 3.3.

Requirements of this Chapter cover plating and framing members of decks and platforms: deck longitudinals, beams, deck transverses, deck girders, hatch end beams, hatch side coamings and hatch end coamings, wash plate in the tanks of tankers.

Additional requirements for the areas of upper deck situated below the superstructures are given in 2.12.5.1 ÷ 2.12.5.3.

2.6.2 Construction..

2.6.2.1 In tankers of 80 m and above, bulk carriers and ore carriers, as well as in oil/dry bulk cargo carriers, and ore/oil carriers, longitudinal system of framing shall be adopted for the strength deck in way of cargo holds (tanks).

Where longitudinal system of framing is adopted, the spacing of deck transverses shall not exceed that of bottom transverses.

2.6.2.2 Provision shall be made for the structural continuity of deck girders of the strength deck in the midship region. If the deck girders are cut at transverse bulkheads, their web plates shall be welded to the transverse bulkheads and attached thereto by brackets.

The web plates of hatch end coamings, deck transverses, hatch end beams and wash plates shall be strengthened by stiffeners and brackets (refer to 1.7.3).

The face plates of deck girders shall be connected to the face plates of hatch end beams by means of diamond plates (refer to 1.7.4.5) whose thickness shall be equal to the greater face plate thickness.

2.6.2.3 On the strength deck, the ends of side coamings at the corners of hatchways shall be either bent along the line of hatch corner rounding and butt-welded to the hatch end coaming or extended, in the form of a bracket, beyond the corner of the hatchway. Provision shall be made for a gradual termination of the bracket above the deck girder web.

The upper edges of coamings acting as deck girders shall be stiffened with face plates and the lower edges of the coamings shall be rounded.

The upper edge of hatch side coaming shall be smooth and their corners shall be well rounded in the transverse direction.

2.6.2.4 The deck girders and deck transverses in way of pillars shall be strengthened by stiffeners or tripping brackets.

Where deck girders are connected to deck transverses and their web height is different, the deck girder web shall be strengthened by brackets fitted in line with the deck transverse. The brackets shall be welded to the face plate of deck transverse, to the web and face plate of deck girder.

Where deck girders are attached to conventional beams, the web of deck girder shall be strengthened by vertical stiffeners.

2.6.2.5 In the case of connection of deck longitudinals to transverse bulkheads, the effective sectional area of the longitudinals shall be maintained.

2.6.2.6 In tankers with two effective longitudinal bulkheads, provision shall be made for a wash plate at the centreline.

2.6.3 Deck loads.

2.6.3.1 The design pressure on the weather deck shall not be less than

$$p = 0,7p_w \geq p_{\min}, \quad (2.6.3.1)$$

where: p_w – wave load at the deck level, as defined in 1.3.2.2;

$p_{\min} = 0,1L + 7$ at the fore end within $0,2L$ from the forward perpendicular;

$p_{\min} = 0,015L + 7$ in the midship region and aft of the midship region;

for regions between the fore end and the midship region, p_{\min} shall be determined by linear interpolation.

For ships of restricted area of navigation the value of p_{\min} For ships of restricted area of navigation the value of φ_r , obtained from Table 1.3.1.5.

2.6.3.2 For weather decks intended to carry deck cargo (except timber and coke), the design pressure shall be taken equal to the cargo pressure p_c , determined by Formula (1.3.4.1).

For weather decks intended to carry timber and coke, the value of h in Formula (1.3.4.1) shall be taken equal to 0,7 times the stowage height of timber and coke on deck.

For lower decks and platforms, the design pressure shall be taken according to 1.3.4.1. For decks where cargo is suspended from beams or deck longitudinals, the design pressure value shall be suitably increased.

For decks and platforms intended for the crew, passengers and equipment, the design pressure shall be determined by Formula (1.3.4.1) while the product hp_{cg} shall not be less than 3,5 kPa.

For platforms in the engine room, the minimum design pressure shall be 18 kPa.

Watertight lower decks and platforms shall be additionally calculated using the test loads, in kPa, as follows:

$$p = 7,5h_p, \quad (2.6.3.2)$$

where: h_p — vertical distance, in m, from deck (platform) plating to air pipe top.

2.6.3.3 The design pressure on the structures of decks and platforms forming boundaries of compartments intended for the carriage of liquids shall be determined in accordance with **1.3.4.2**.

2.6.4 Scantlings of deck members.

2.6.4.1 Thickness of deck plating.

2.6.4.1.1 The thickness of strength deck plating outside the line of hatch openings, taking deck longitudinals into account, shall be that necessary to give the hull section modulus for strength deck, as required by **1.4.6**.

The adopted thickness of strength deck plating within midship region shall be in accordance with the requirements for buckling strength (refer to **1.6.5**).

2.6.4.1.2 The plating thickness for decks and platforms shall not be less than determined by Formula (1.6.4.4) taking:

$$m = 15,8;$$

p – as defined in **2.6.3**;

for strength deck

$k_{\sigma} = 0,3k_d \leq 0,6$ in the midship region for $L \geq 65$ m and transverse framing system;

k_d – as determined by Formula (2.2.4.1);

$k_{\sigma} = 0,6$ in the midship region for $L = 12$ m and the deck is transverse framing system.

Where $12 < L < 65$ m, k_{σ} shall be determined by linear interpolation taking $k_{\sigma} = 0,45$ for $L = 65$ m.

$k_{\sigma} = 0,6$ in the midship region for longitudinal framing system;

$k_{\sigma} = 0,7$ at the ends of the ship within $0,1L$ from the fore or after perpendicular.

For regions between the midship region and the above portions of ship's ends, k_{σ} shall be determined by linear interpolation;

for the second continuous deck situated above $0,75D$ from the base line:

$k_{\sigma} = 0,65k_d \leq 0,8$ in the midship region for $L \geq 65$ m and transverse framing system;

k_d – as determined by Formula (2.2.4.1);

$k_{\sigma} = 0,8$ in the midship region for $L = 12$ m and the deck is transverse framing system.

Where $12 < L < 65$ m, k_{σ} shall be determined by linear interpolation taking $k_{\sigma} = 0,73$ for $L = 65$ m.

$k_{\sigma} = 0,8$ in the midship region for longitudinal framing system;

$k_{\sigma} = 0,9$ at the ends of the ship within $0,1L$ from the fore or after perpendicular.

For regions between the midship region and the above portions of ship's ends, k_{σ} shall be determined by linear interpolation;

for other lower decks and platforms, $k_{\sigma} = 0,9$.

2.6.4.1.3 If the engine room is located aft, the plating thickness and the scantlings of deck longitudinals, at the poop (aft deckhouse) front shall be maintained abaft the poop (deckhouse) front for a length of at least the width of machinery casing opening.

If the distance from the fore edge of casing opening to the poop (deckhouse) front is less than the width of the opening, additional strengthening of deck may be required in this region.

2.6.4.1.4 If the thickness of strength deck plating is taken less than the side plating thickness, a deck stringer plate shall be provided. The width b , in mm, of the strength deck stringer plate shall not be less than

$$b = 5L + 800 \leq 1800, \quad (2.6.4.1.4)$$

and the thickness of stringer plate shall not be less than that of side shell plating (sheerstrake).

2.6.4.1.5 The thickness s_{\min} in mm, of deck plating and platforms shall not be less than:

for upper deck between the ship's side and line of large openings (tank decks of tankers) in the midship region

$$s_{\min} = (0,05L + 4)\sqrt{\eta} \quad \text{for } L < 100 \text{ m}; \quad (2.6.4.1.5-1)$$

$$s_{\min} = (0,02L + 7)\sqrt{\eta} \quad \text{for } L \geq 100 \text{ m}; \quad (2.6.4.1.5-2)$$

for upper deck at the ends of the ship and inside the line of large openings, as well as for the second deck

$$s_{\min} = (0,04L + 4)\sqrt{\eta} \quad \text{for } L < 100 \text{ m}; \quad (2.6.4.1.5-3)$$

$$s_{\min} = (0,01L + 7)\sqrt{\eta} \quad \text{for } L \geq 100 \text{ m}; \quad (2.6.4.1.5-4)$$

for the third deck and other lower decks and platforms

$$s_{\min} = (0,01L + 5)\sqrt{\eta}; \quad (2.6.4.1.5-5)$$

where: η – as defined in **1.1.4.3**.

Where $L > 300$ m L shall be taken equal to 300 m.

Where the adopted spacing is less than the standard one (refer to 1.1.3) for ships of unrestricted service **A**, and restricted area of navigation **R1**, **A-R1**, the minimum deck plating and platform thickness may be reduced in proportion to the ratio of adopted spacing to the standard spacing, but not more than by 10 %.

In any case, the minimum thickness shall not be less than 5,5 mm.

In way of compartments intended for the carriage of liquids, the thickness of plating and deck structural members (including perforated members) shall not be less than required by **3.5.4** for tankers and not less than determined by Formula (2.7.4.1-2) for other ship types.

2.6.4.2 The section modulus of deck longitudinals shall not be less than determined according to **1.6.4.1** and **1.6.4.2** taking:

p = as defined in **2.6.3**;

$m = 12$;

for weather deck

$k_{\sigma} = 0,45k_d \leq 0,65$ in the midship region;

k_d – shall be determined by Formula (2.2.4.1);

$k_{\sigma} = 0,65$ at the ends of the ship within $0,1L$ from the fore or after perpendicular.

For regions between the midship region and the above portions of ship's ends, k_{σ} shall be determined by linear interpolation;

for other decks $k_{\sigma} = 0,75$.

2.6.4.3 When the decks are framed transversely, the scantlings of beams shall satisfy the following requirements:

.1 the section modulus of beams shall not be less than that determined from **1.6.4.1** taking:

p – as defined in **2.6.3**;

$m = 12$;

$k_{\sigma} = 0,65$;

.2 the inertia moment i_b , in cm^4 , of weather deck beams in the midship region of ships 65 m and greater in length shall be determined on the basis of a buckling strength calculation of deck grillage using beam models in accordance with **1.6.5**.

For beams having two or more intermediate rigid supports, the required inertia moment may be determined, alternatively to the grillage calculation, by the following formula:

$$i_{\sigma} = 6,33 \cdot (s/a)^3 \cdot l^4 \cdot \varphi \cdot \chi \cdot 10^{-3}, \quad (2.6.4.3.2)$$

where: l – beam span, in m, between supports;

$\varphi = 1$ where $\sigma_c \leq 0,5R_{eH}$;
 $\varphi = 4 \cdot \sigma_c \cdot (1 - \sigma_c / R_{eH}) / R_{eH}$ where $\sigma_c > 0,5R_{eH}$;
 $\chi = \lambda^2 / (4 - 1,5\lambda^4)$;
 $\lambda = 4 \cdot \sigma_c \cdot (a/s)^2 / \varphi$, but not more than 1;
 σ_c – compressive stresses as determined according to **1.6.5.1**;
 s – actual deck plating thickness, in mm.

2.6.4.4 The scantlings of deck framing members, such as deck transverses, deck girders, hatch coamings and hatch end beams, shall be determined on the basis of deck grillage calculation using beam models, except for cases mentioned under **2.6.4.5** ÷ **2.6.4.8**.

Design loads shall be chosen in accordance with **2.6.3**. Where pillars are fitted, the interaction between deck grillage and upper and/or lower structures shall be considered with regard for the arrangement of pillars. Permissible stress factors shall be taken as follows

strength deck

for deck girders and hatch side coamings which are arranged in line with the deck girders,

$k_\sigma = 0,35k_d \leq 0,65$ in the midship region for $L \geq 65$ m;

k_d – shall be determined by Formula (2.2.4.1);

$k_\sigma = 0,65$ in the midship region for $L = 12$ m.

Where $12 < L < 65$ m, k_σ shall be determined by linear interpolation taking $k_\sigma = 0,5$ for $L = 65$ m;

$k_\sigma = 0,65$ at the ends of the ship within $0,1L$ from the fore or after perpendicular.

For regions between the midship region and the above portions of ship's ends, k_σ shall be determined by linear interpolation;

for deck transverses and half beams, hatch coamings, which are not arranged in line with the deck girders and hatch end beams

$k_\sigma = 0,65$;

for deep members, which are calculated using the shear stresses

$k_\sigma = 0,65$;

for deep members of other decks and platforms

$k_\sigma = k_\tau = 0,7$.

The deep members of weather deck in the midship region shall also comply with the requirements of **2.6.4.9**.

2.6.4.5 In tankers with two effective longitudinal bulkheads and with no deck girders, and where longitudinal system of framing is adopted, the scantlings of deck deep members in the centre tank shall comply with the following requirements:

.1 the section modulus of deck transverse shall not be less than determined according to **1.6.4.1** and **1.6.4.2**, the sectional area of deck transverse web, excluding openings, shall not be less than determined from **1.6.4.3** taking:

p – as defined in **2.6.3**;

k_σ and k_τ – as defined in **2.6.4.4**;

$l = B_1$, B_1 – breadth, in m, of centre tank;

$m = m_{b,t}$;

$N_{\max} = 0,7n_{b,t}pal$;

$m_{b,t}$ and $n_{b,t}$ shall be determined from Table 2.3.4.2.2 depending upon the parameter m and the number of deck transverses within the tank:

$\mu = \alpha^{4/3}(L_1/B_1)^3$;

$\alpha = W_{b,t}/W_{w,p}$;

where: L_1 – tank length, in m;

$W_{b,t}$ – section modulus of deck transverse complying with the present requirements;

$W_{w,p}$ – section modulus of wash plate complying with the present requirements.

The value of the parameter α is optional, but shall not be greater than 0,6; the value of the parameter m shall not exceed 1,5.

The deck transverse section modulus shall not be less than $\alpha W_{w,p}$;

.2 the section modulus of wash plate shall not be less than stipulated under **1.6.4.1** and **1.6.4.2**, the sectional area of wash plate web, excluding openings, shall not be less than stipulated under **1.6.4.3** taking:

p – as defined in **2.6.3**;

k_{σ} and k_{τ} – as determined for deck girders in accordance with **2.6.4.4**;

$l = L_1$, where L_1 – = tank length, in m;

a – = distance, in m, between the wash plate and longitudinal bulkhead;

$m = m_{c.g.}$;

$N_{max} = 0,7n_{c.g}pal$;

$m_{c.g.}$ and $n_{c.g.}$ shall be obtained from Table 2.3.4.2.2 depending upon the parameter μ and the number of deck transverses within the tank; μ shall be determined in accordance with **2.6.4.5.1**.

Besides, the section modulus of wash plate shall not be less than $W_{b,t} / \alpha$, where $W_{b,t}$ – is the deck transverse section modulus complying with the requirements of **2.6.4.5.1**; α – shall be determined in accordance with **2.6.4.5.1**.

Along the free edge, the wash plate shall be strengthened with a face plate the sectional area of which shall not be less than that of the deck transverse face plate.

2.6.4.6 The deck transverses of tankers having a single longitudinal bulkhead, tankers with two longitudinal bulkheads and no deck girders or strengthened longitudinals (in wing tanks only), as well as deep half beams, deep beams and hatch end coamings of dry cargo ships, which may be considered as members with rigid supports shall have a section modulus not less than stipulated under **1.6.4.1** and **1.6.4.2** and a web sectional area, excluding openings, not less than stipulated under **1.6.4.3** taking:

p – as defined in **2.6.3**;

k_{σ} and k_{τ} – as defined in **2.6.4.4**;

$m = 10$;

$N_{max} = 0,5pal$.

2.6.4.7 Deck girders and hatch side coamings shall satisfy the following requirements:

.1 deck girders and hatch side coamings which may be considered as members with rigid supports shall have a section modulus not less than determined in accordance with **1.6.4.1** and **1.6.4.2**, and a web sectional area, excluding openings, not less than stipulated under **1.6.4.3** taking:

p – as defined in **2.6.3**;

k_{σ} and k_{τ} – as defined in **2.6.4.4**;

$N_{max} = 0,5pal$;

$m = 10$ for intercostal deck girders, hatch side coamings when determining the section modulus at supporting section taking into account the bracket, if any, included in this section;

$m = 18$ for continuous deck girders and hatch side coamings when determining the section modulus in the span of a deck girder, hatch side coaming;

.2 for ships less than 30 m in length, the deck girder web thickness need not be taken greater than the deck plating thickness, and the hatch coaming web thickness shall be 1 mm greater than the thickness of deck plating;

.3 if the side coamings of strength deck hatches terminate in brackets, the length l_b , in m, of these brackets on the deck shall be:

$$l_b \geq 0,75h_b \quad \text{at } R_{eH} \leq 315 \text{ MPa};$$

(2.6.4.7.3)

$$l_b \geq 1,50 h_b \quad \text{at } R_{eH} = 390 \text{ MPa},$$

where: h_b – = height of coaming above deck, in m.

For the intermediate values of R_{eH} the bracket length shall be determined by linear interpolation;

.4 if containers or other cargo are stowed on cargo hatch covers, the scantlings of stiffeners for vertical coaming plates shall be so chosen as to consider both the horizontal and vertical components of inertia forces acting upon the stiffeners in the event of rolling.

2.6.4.8 If deck deep member can be considered separately from others, its section modulus shall not be less than stipulated under 1.6.4.1 and 1.6.4.2 using the design loads and factor k_{σ} determined from **2.6.4.4** and

with $m = 10$.

The sectional area of such member shall not be less than determined by **1.6.4.3** taking:

k_{τ} as stipulated under **2.6.4.4**;

$N_{\max} = 0,5pal$;

p – as defined in **2.6.3**.

2.6.4.9 In the midship region of a ship 65 m and greater in length, the deep member scantlings of the weather deck shall comply with the buckling strength requirements of **1.6.5**, the buckling strength values to be determined by calculation of the deck grillage using beam models.

Where deck is framed longitudinally and no deck girders are fitted, or deck girders serve as rigid supports for deck transverses, the required moment of inertia $I_{d,t}$, in cm^4 , of deck transverses may be determined by the following formula, as an alternative to grillage calculation:

$$I_{d,t} = 0,76 \cdot (l/c)^3 \cdot (l/a_1) \cdot i \cdot \varphi \cdot \chi, \quad (2.6.4.9)$$

where: l – span of deck transverse between supports, in m;

c – distance, in m, between deck transverses;

a_1 – spacing of deck longitudinals, in m;

i – actual inertia moment, in cm^4 , of deck longitudinal provided with a face plate;

$\varphi = 1$ where $1,15\sigma_c \leq 0,5R_{eH}$;

$\varphi = 4,6 \cdot \sigma_c \cdot (1 - 1,15\sigma_c / R_{eH}) / R_{eH}$ where $1,15\sigma_c > 0,5R_{eH}$;

$\chi = \lambda^2 / (4 - 1,5\lambda^4)$;

$\lambda = 1,15 \cdot \sigma_c / (\varphi \cdot \sigma_e)$;

σ_c – compressive stress as defined in **1.6.5.1**;

σ_e – actual Euler stresses in deck longitudinals, determined in accordance with **1.6.5.4**.

2.6.5 Special requirements.

2.6.5.1 The requirements for hatch openings as given below apply to single hatches whose scantlings do not exceed those stipulated under **2.6.1**.

The openings are supposed to be arranged in the fore-and-aft direction with their greater side.

2.6.5.1.1 For the strength deck within $0,6L$ amidships if $L \geq 65$ m and $0,5L$ if $40_M \leq L < 65$ m, the corner radii of openings in cargo hatches and engine and boiler casings shall comply with the following requirements:

when the corners are rounded along the circumferential arc with a radius r , in m:

$$r \geq 0,1ab_1; \quad (2.6.5.1.1-1)$$

the corner radii of openings in cargo hatches and engine and boiler casings shall comply with the following requirements: when the corners are rounded along the circumferential arc with a radius r , in m d_1 , in m, to the length of transverse half-axis c_1 in m, being equal to 2 2,

$$c_1 \geq 0,07ab_1; \quad (2.6.5.1.1-2)$$

where: $a = 1$, if the corners of openings are not reinforced by thickened insert plates;

$a = 0,7$, if the corners of openings are reinforced by thickened insert plates;

$b_1 = c$, when $c \leq c_0$ for adjacent edges of successive openings;

$b_1 = b$, when $c > c_0$ for adjacent edges of successive openings and in all other cases;

c – distance, in m, between adjacent edges of successive openings (length of landing between openings);

b – breadth, in m, of opening;

$c_0 = B \cdot (b/l) \cdot \{ [2/(\sqrt{(b/B)}) - 1] \}$;

l – length of opening, in m.

The size of thickened insert plates by which the corners of openings are reinforced shall be in compliance with Fig. **2.6.5.1.1** or with the requirements of **2.6.5.1.5** where r shall be determined by Formula (2.6.5.1.1-1) if the rounding is made along the circumferential arc;

$r = c_1$ for the transverse dimensions of the insert plate, and $r = d_1$ for its longitudinal dimensions if the rounding is made along the elliptical arc, and c_1 shall be determined by Formula (2.6.5.1.1-2).

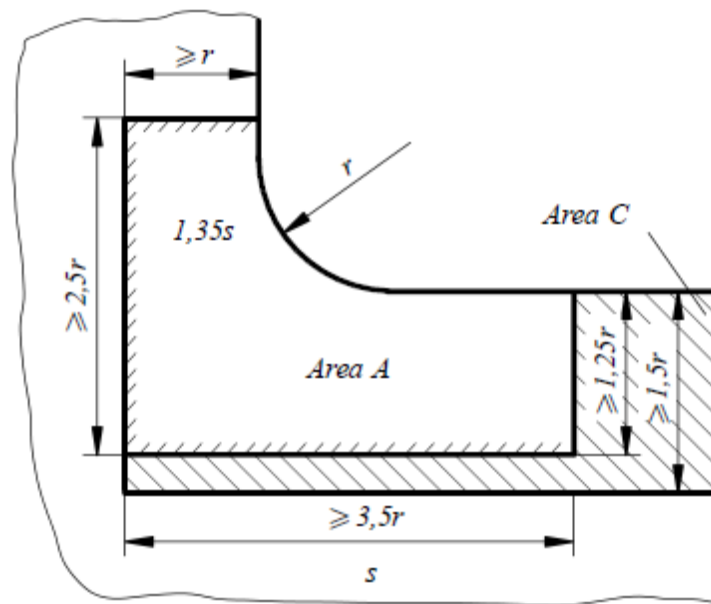

Fig. 2.6.5.1.1

2.6.5.1.2 For the strength deck outside the area indicated in **2.6.5.1.1** and for the second continuous deck situated above $0,75D$ from the base line, the corner radii of openings, as required by **2.6.5.1.1**, may, in accordance with **1.1.3**, be reduced by half in the midship region.

The minimum radius shall not be taken less than $0,2$ m. For other regions, other decks and platforms, as well as for ships less than 40 m in length, the minimum corner radius of openings in cargo hatches and engine and At corners of openings in the cargo hatches of decks (irrespective of their location over the length and depth of the hull) exposed to low temperatures, the radii of curvature shall comply with the requirements for similar structures of the strength deck, situated in the midship region (refer to **2.6.5.1.1**).

2.6.5.1.4 4 In the area A (refer to Fig. 2.6.5.1.1), butts of deck plating and coaming plates, butt welds of primary and deep longitudinal members, openings welding of shackles, frames, etc., as well as mounting parts, to deck plating are not permitted.

In the area C (refer to Fig. 2.6.5.1.1), only small openings generally of a round or elliptical shape with a minimum size not exceeding $20s$ (s – deck plating thickness, in mm) are permitted. Penetration of welds to longitudinal edges of openings shall be avoided as far as practicable.

If the deck plating is terminated at a hatch coaming (or engine casing) and welded thereto, full penetration welds shall be used. Where the deck plating extends inside a hatch coaming, the free edges of plating shall be smooth within the hatch and free of weld attachments.

If the hatch side coaming terminates in a bracket, the bracket shall not coincide with the butt joint of the deck plating.

2.6.5.1.5 If the lost cross-sectional area of deck shall be compensated in way of an isolated opening, reinforcement shall be applied as shown in Fig. 2.6.5.1.5. The value of factor k shall be selected proceeding from the relationship between the deck plating thickness s , insert plate thickness s_1 and opening width b , but shall not be taken less than $k = 0,35s/s_1$.

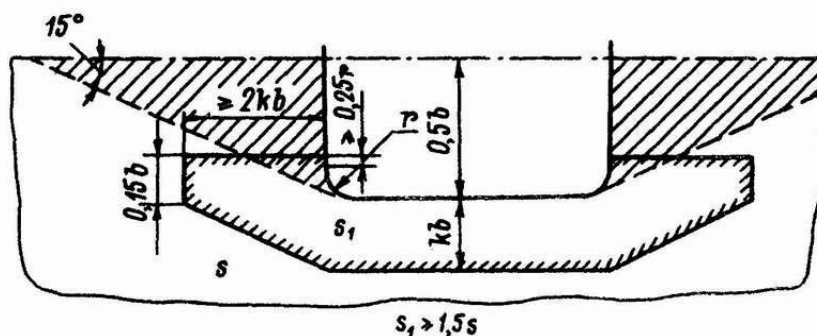

Fig. 2.6.5.1.5

2.6.5.1.6 The deck plating thickness between transverse edges of adjacent successive openings in cargo hatches and engine casings (refer to 2.6.5.1.1) within their width except for the transverse dimensions of rounding shall not be less than stipulated under 2.6.4.1.5. The thickness s_{\min} is permitted in way of transverse edges of isolated openings in the area shown in Fig. 2.6.5.1.6.

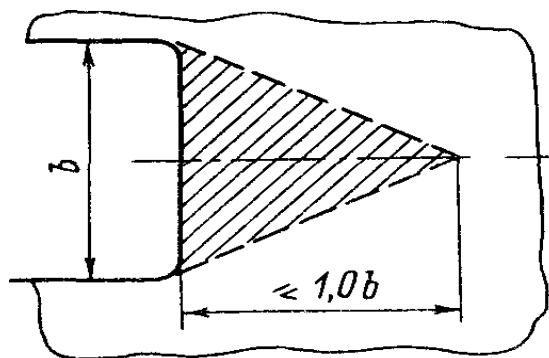

Fig. 2.6.5.1.6

If longitudinal system of framing is adopted, the deck plating between hatch end coamings shall be additionally strengthened by fitting of transverse intercostal stiffeners at every frame.

2.6.5.1.7 Single openings in the strength deck and in the second continuous deck situated above $0,75D$ from the base line, in areas within the midship region, as mentioned in 2.6.5.1.1 and 2.6.5.1.2, and between the ship's side and the line of hatch openings in ships of 40 m and greater in length shall be as small as practicable and be arranged well clear of the corners of openings in cargo hatches and engine and boiler casings, as well as of the ends of superstructures.

Rectangular and circular openings in the above areas need not be reinforced, if their width (diameter) is less than 20 times the deck plating thickness in way of the opening, or 300 mm, whichever is less.

No openings are permitted in the thickened insert plates by which the corners of cargo hatches and engine and boiler casings are reinforced, as well as in the thickened deck stringer plates at the ends of superstructures and at the toes of brackets in which side coamings terminate.

Openings (including rectangular ones) shall not be reinforced when located inside the line of large hatchway openings not more than $0,25b$ from the centreline and $0,5b$ from the transverse edges of a cargo hatchway opening (where b is the width of cargo hatch, in m).

For isolated openings in the area indicated in Fig. 2.6.5.1.6, reinforcement is not required. If the distance between the edge of an opening in the strength deck and ship's side (or a hatch side coaming) is less than twice the opening width, appropriate reinforcement shall be provided irrespective of the width and shape of opening. The aforesaid distance shall not be less than 75 mm.

The corners of rectangular openings shall be rounded with a radius.

In general, $r_{\min} = 0,1b$ (where b is the width of opening, in m). In any case, the minimum radius of curvature shall not be taken less than twice the plating thickness in way of the opening or 50 mm, whichever is the greater.

2.6.5.2 The thickness s , in mm, of the coamings of ventilators (ventilating tubing, ducts, trunks, etc.) on the freeboard deck and quarter deck, as well as on the open decks of superstructures within $0,25L$ from the forward perpendicular shall not be less than:

$$s = 0,01d_k + 5, \quad (2.6.5.2)$$

where: d_k – internal diameter or length of the greater side of a coaming section, in mm.

The thickness s shall not be less than 7 mm, but it need not be greater than 10 mm.

In ships of restricted areas of navigation **R2, A-R2, R2-S, R2-RS, A-R2-S, A-R2-RS, B-R3-S, B-R3-RS, C-R3-S, C-R3-RS, R3-S, R3-RS, R3, R3-IN, D-R3-S, D-R3-RS** less than 24 m in length, the thickness s , in mm, of ventilator coamings shall not be less than:

$$s = 0,01d + 4, \quad (2.6.5.2-1)$$

or

$$s = s_d + 1, \quad (2.6.5.2-2)$$

where: d – internal diameter or length of the greater side of a coaming section, in mm;

s_d – thickness of deck plating, in mm.

whichever is the greater

The thickness of coamings on decks of the first tier superstructures situated outside $0,25L$ from the forward perpendicular may be reduced by 10 % as compared to that required for coamings on freeboard deck and raised quarter deck.

Where the thickness of deck plating is less than 10 mm, a welded insert or doubling plate shall be fitted in way of the coaming, having a thickness equal to at least 10 mm, length and breadth not less than twice the diameter or twice the length of the greater side of the coaming section. In case of an efficient connection of the coaming to the deck framing, fitting of welded insert or doubling plate is not required.

Where the height of a ventilator coaming is greater than 0,9 m and the coaming is not supported by adjacent hull structures, brackets shall be fitted to attach the coaming to the deck.

The height of ventilator coamings shall be determined in accordance with **7.8**, Part III "Equipment, Arrangements and Outfit".

The structure of companionway and skylight coamings shall have strength equivalent to that of cargo hatches, whereas the thickness of the coamings shall not be taken less than 7 mm, but need not exceed the thickness of deck plating in way of the coaming.

2.7 BULKHEADS, PROPELLER SHAFT TUNNEL

2.7.1 General and definitions.

2.7.1.1 Requirements are given in this Chapter for various types of bulkheads, propeller shaft tunnel and cofferdams. Requirements for cofferdam bulkheads are given under **3.3**.

2.7.1.2 Definitions.

For the purpose of this Chapter, the following definitions have been adopted.

Wash bulkhead is a bulkhead with openings, fitted inside a compartment in order to reduce impact pressure due to the movement of liquid therein.

Watertight (emergency) bulkhead is a bulkhead restricting the flow of water through ship spaces in the case of emergency.

Cofferdam bulkhead is a bulkhead having two parallel tight platings, either strengthened with vertical or horizontal stiffeners or not, which are connected to each other by plate structures perpendicular to the platings: vertical structures (diaphragms) and/or horizontal structures (platforms). If no diaphragms and platforms are fitted, the structure shall be considered as two bulkheads bounding the cofferdam.

Partial bulkhead is a bulkhead fitted in a compartment or part thereof, which shall ensure additional support for deck structures.

Tight bulkhead is a bulkhead proof against water and other liquids.

Tank/cargo tank bulkhead is a bulkhead bounding a ballast, fuel or other tank, as well as a cargo tank of tanker.

2.7.1.3 The total number of transverse watertight bulkheads, including fore and after peak bulkheads, shall be not less than specified in Table 2.7.1.3. These requirements apply to cargo ships only and are minimum.

Where compliance with subdivision requirements shall be ensured, the number and disposition of watertight bulkheads (and of partial watertight bulkheads) shall be determined proceeding from the requirements of Part V "Subdivision".

All the transverse watertight bulkheads located between fore and after peak bulkheads shall be carried to the freeboard deck.

Table 2.7.1.3

Length of the ship, in m	Total number of bulkheads	
	Machinery amidships	Machinery aft ¹
Up to 65	4	3
65 to 85	4	4
85 to 105	5	5
105 to 125	6	6
125 to 145	7	6
145 to 165	8	7
165 to 185	9	8
Above 185	In accordance with Part V "Subdivision".	

¹ With after peak bulkhead forming after boundary of the engine room.

2.7.1.4 Peak and engine room bulkheads, shaft tunnels shall also comply with the requirements of **1.1.6.3**.

2.7.2 Construction.

2.7.2.1 Tight bulkheads may be either plane or corrugated. Wash bulkheads with openings shall be plane bulkheads.

For the construction of longitudinal tight bulkheads, as well as for the tight bulkheads of log and depth sounder wells, escape trunks, propeller shaft tunnel, etc., the same requirements apply as for transverse tight bulkheads.

In bulkheads, watertight steps and recesses are permitted.

In tankers, the longitudinal bulkheads shall be tight throughout the cargo tank region (including pump rooms and cofferdams) with the exception of the third bulkhead at the centreline which may be constructed as a wash bulkhead.

At intersections of longitudinal and transverse bulkheads, structural continuity of longitudinal bulkheads shall be ensured.

The termination of longitudinal bulkheads shall be smooth.

Partial bulkheads shall be plane bulkheads.

2.7.2.2 In corrugated longitudinal bulkheads, the corrugations shall generally be arranged horizontally, while in transverse bulkheads the arrangement of corrugations may be both horizontal and vertical. Plane bulkheads shall be strengthened by vertical or horizontal stiffeners.

The vertical and horizontal stiffeners of plane bulkheads as well as the vertical and horizontal corrugations of corrugated bulkheads may be supported by horizontal girders or vertical webs respectively.

The horizontal girders and vertical webs shall be stiffened in accordance with the requirements of **1.7.3**.

Partial bulkheads shall be strengthened by vertical webs.

2.7.2.3 The end attachments of bulkhead framing members shall comply with the following requirements:

.1 the ends of vertical webs and horizontal stiffeners of bulkheads shall generally be attached by brackets complying with the requirements of **1.7.2.2**. Bracket attachments are required for the ends of main framing of forepeak bulkhead below the freeboard deck;

.2 if transverse system of framing is adopted, the brackets by which the vertical webs of transverse bulkheads are attached to deck plating and inner bottom plating (bottom plating) shall be carried to the beam or floor nearest to the bulkhead and welded thereto.

Where transverse framing system is adopted, the brackets by which the horizontal stiffeners of bulkheads are attached to the side or other bulkhead shall be carried to the frame or vertical stiffener nearest to the bulkhead and welded thereto;

.3 when the vertical stiffeners of bulkheads are cut at decks, platforms or horizontal girders and no brackets are fitted, the stiffener ends shall be welded to deck or platform plating, to horizontal girder web, or sniped at ends;

.4 the end attachments of vertical webs and horizontal girders shall comply with the requirements of 1.7.2.3.

Where there are no horizontal girders on longitudinal bulkheads and/or side stringers at the level of the horizontal girder brackets of transverse bulkheads, the brackets shall be carried to the nearest vertical web on longitudinal bulkhead and/or the nearest frame and welded thereto.

If the vertical web on a transverse bulkhead is not in line with the centre girder or side girder, a bracket shall be fitted in the double bottom under the bracket by which the lower end of the vertical web is attached.

2.7.2.4 The attachments of corrugated bulkheads shall comply with the following requirements:

.1 where a horizontally corrugated bulkhead is attached to deck and bottom (inner bottom) or a vertically corrugated bulkhead is attached to ship's sides and longitudinal bulkheads, provision shall be made for flat transition areas whose structure, thickness and stiffening shall be in compliance with the requirements for plane bulkheads;

.2 attachment of corrugation ends shall be effected by welding them directly to the inner bottom plating (bottom plating), side plating, deck plating, etc. In so doing, attention shall be given to eliminating hard spots (refer to 1.7.1.4) in the above structures;

.3 requirements for the attachments of corrugated bulkheads in bulk carriers are given in 3.3.2.

2.7.2.5 The ends of the shaft tunnel stiffeners shall be attached with brackets similar to the stiffeners of waterproof and tanks bulkheads.

2.7.3 Bulkhead loads.

2.7.3.1 The design pressure p , in kPa, on watertight bulkhead structures and propeller shaft tunnel shall be taken equal to:

$$P = \alpha \cdot z_b, \quad (2.7.3.1)$$

where: $\alpha = 10$ for forepeak bulkhead structures;

$\alpha = 7,5$ elsewhere;

z_b – distance, in m, as measured at the centreline, from the point of design load application to its upper level; the upper load level is: the bulkhead deck for watertight bulkheads and propeller shaft tunnel, the upper edge of forepeak bulkhead for the forepeak bulkhead.

If partial watertight bulkheads are fitted on the bulkhead deck in line with the watertight bulkheads or in close vicinity to them, z_b shall be measured to the upper edge of the watertight partial bulkheads.

In any case, the design pressure shall be not less than 12 kPa for watertight bulkhead structures and not less than 16 kPa for forepeak bulkhead structures.

2.7.3.2 The design pressure on the bulkheads of tanks, cargo tanks and water ballast holds shall be determined in accordance with 1.3.4.2.

The design pressure on the wash bulkheads and plates shall be determined by Formulae (1.3.4.2.2-1) and (1.3.4.2.2-2), but shall not be less than $p_{min} = 25$ kPa.

The design pressure on bulkheads bounding heavy bulk cargo holds shall be determined in accordance with 1.3.4.3.

2.7.4 Scantlings of bulkhead members.

2.7.4.1 The thickness of bulkhead plating shall be not less than determined by Formula (1.6.4.4) taking:

p – as defined in 2.7.3;

$m = 15,8$;

for the longitudinal bulkheads of tankers 65 m or greater in length, with transverse framing in the midship region:

$k_\sigma = 0,55k_b \leq 0,8$ at the level of base line;

k_b – shall be determined by Formula (2.2.4.1);

$k_\sigma = 0,55k_d \leq 0,8$ at the upper deck level;

k_d – shall be determined by Formula (2.2.4.1);

$k_\sigma = 0,8$ in way of $(0,4 \div 0,5)D$ from the base line.

For intermediate regions over the ship's depth, k_σ shall be determined by linear interpolation.

$k_{\sigma} = 0,8$ for $L = 12$ m.

Where $12 < L < 65$ m k_{σ} shall be determined by linear interpolation taking $k_{\sigma} = 0,68$ for $L = 65$ m at the level of base line and upper deck.

For regions between the midship region and the above portions of ship's ends, k_{σ} shall be determined by linear interpolation;

$k_{\sigma} = 0,9$ for other bulkheads.

In ships of 50 m in length, the thickness of watertight bulkhead plating may be reduced by 0,5 mm, and in ships of 40 m in length or below, by 1 mm. For intermediate ship lengths, the reduction in thickness shall be determined by linear interpolation.

In tankers, the thickness of top and bottom strakes of longitudinal bulkheads shall comply with the requirements for side plating, as given in **2.2.4**, with regard for the liquid cargo pressure.

The plating thickness s_{\min} , in mm, of watertight bulkheads and bulkheads of lubricating oil tanks shall not be less than:

$$s_{\min} = 4 + 0,02L, \quad (2.7.4.1-1)$$

Where $L > 150$ m, L shall be taken equal to 150 m.

The thickness of bottom plates of bulkheads shall exceed the above value by 1 mm, determined by the Formula (2.7.4.1-1), but shall not be less than 6 mm.

For tank bulkheads (except lubricating oil tanks), the thickness s_{\min} , in mm, of plating, face plates and webs of framing members shall not be less than:

$$s_{\min} = 5 + 0,015L, \quad (2.7.4.1-2)$$

$$6,0 \text{ mm} \leq s_{\min} \leq 7,5 \text{ mm}.$$

In tankers, the minimum bulkhead plating thickness in way of cargo and ballast tanks shall not be less than that required by **3.5.4**.

Bulkhead plating may have a thickness not exceeding that of relevant shell plating strakes and deck plating, where the spans and yield stress values are identical. The same applies to the thickness relationship of bulkhead bottom plating and inner bottom plating (bottom plating).

The breadth of top and bottom strakes of bulkheads shall be determined in accordance with **2.7.5.1**. Where stern tubes penetrate through bulkhead plating, the thickness of the latter shall be doubled.

The thickness of corrugated bulkheads shall be determined in accordance with **1.6.4.5** with regard for the requirements for the section moduli of vertical and horizontal stiffeners, as specified in **2.7.4.2**.

2.7.4.2 The section modulus of vertical and horizontal stiffeners of bulkheads shall not be less than stipulated under **1.6.4.1** and 1.6.4.2 **taking**:

p – as defined in **2.7.3**;

m – as obtained from Table 2.7.4.2;

Table 2.7.4.2

Framing members	m
Single span vertical stiffeners:	
- both ends sniped	8
- upper end sniped, lower end welded to supporting structure	9
- both ends welded to supporting structure	10
- upper end welded to supporting structure, lower end bracketed ¹	14
- both ends bracketed ¹	18
Multispan vertical stiffeners:	
- within span	18
- within intermediate supporting section, where stiffener is continuous through supporting structure ²	12
Horizontal stiffeners	12
¹ Additionally, strength in the supporting section shall be verified, considering the bracket as part of the section, with $m=12$.	

² With regard for a bracket, if fitted, in the supporting section

for horizontal stiffeners of longitudinal bulkheads fitted in the midship region of tankers 65 m and greater in length:

$k_{\sigma} = 0,55k_b \leq 0,75$ at the level of base line;

k_b – shall be determined by Formula (2.2.4.1);

$k_{\sigma} = 0,55k_d \leq 0,75$ at the upper deck level;

k_d – shall be determined by Formula (2.2.4.1);

$k_{\sigma} = 0,75$ within $(0,4 \div 0,5)D$ from the base line.

For intermediate regions over the ship's depth, k_{σ} shall be determined by linear interpolation.

$k_{\sigma} = 0,75$ for $L = 12$ m.

Where $12 < 65$ m, k_{σ} shall be determined by linear interpolation, taking $k_{\sigma} = 0,65$ for $L = 65$ m at the base line and upper deck level;

$k_{\sigma} = 0,75$ at the ends of the ship within $0,1L$ from the fore or after perpendicular.

For regions between the midship region and the above portions of ship's ends, k_{σ} shall be determined by linear interpolation;

$k_{\sigma} = 0,75$ for other girders of bulkhead framing.

$m=10$ for corrugations;

$m = 13$ for vertical corrugations of bulkheads whose top and bottom ends are attached to deck and bottom or to inner bottom by transverse members of rectangular or trapezoidal section and by supports of trapezoidal section complying with 3.3, respectively.

Horizontal stiffeners of longitudinal bulkheads fitted at a distance of $0,15D$ from deck and bottom shall comply with the buckling strength requirements of 1.6.5.

For tank bulkheads (except lubricating oil tanks), the thickness of member webs and face plates as well as of their stiffening brackets shall not be less than required by Formula (2.7.4.1-2), and for the bulkheads of tankers in way of cargo and ballast tanks it shall not be less than stipulated under 3.5.4.

2.7.4.3 Bulkhead vertical webs and horizontal girders shall satisfy the following requirements:

.1 the section modulus and web sectional area, excluding openings, of the vertical webs of bulkheads whose structure does not include horizontal girders, and of the horizontal girders of bulkheads whose structure does not include vertical webs, shall not be less than stipulated under 1.6.4.1 - 1.6.4.3 taking:

$N_{\max} = npal$;

p – as defined in 2.7.3;

m, n for the longitudinal bulkheads of tankers shall be determined from Table 2.7.4.3-1 depending upon the number of cross ties fitted in wing tanks between deep members of bulkhead and of ship's side;

for other bulkheads for which vertical webs are provided, but horizontal girders are omitted, or vice versa, the values of m and n shall be obtained from Table 2.7.4.3-2;

l – span, including the brackets, in m;

k_{σ} – is determined for horizontal girders of longitudinal bulkheads in tankers in the same way as for the horizontal stiffeners of those bulkheads in accordance with 2.7.4.2;

for other webs and girders, $k_{\sigma} = 0,75$;

$k_{\tau} = 0,75$;

Table 2.7.4.3.1-1

Member	Parameter	Number of cross ties			
		0	1	2	3
Vertical web	m	11	24	24	24
	n	0,5	0,325	0,3	0,275
Horizontal girder	m	18	36	36	36
	n	0,5	0,35	0,3	0,3

Таблица 2.7.4.3.1-2

Member	m	n
Vertical web:		
- in holds or tanks	11	0,5
- in 'tween decks	10	0,5

Horizontal girder:		
- in tanks	10	0,5
- in wing tanks	18	0,5

.2 where the bulkhead structure incorporates both vertical webs and horizontal girders, the scant-lings of those members shall be determined on the basis of grillage calculation using beam models, with design loads as stipulated under 2.7.3 and permissible stress factors as stipulated under 2.7.4.3.1;

.3 for the girders and webs of corrugated bulkheads, the lowest cross section shall be adopted as the design cross section; the face plate width shall be determined in accordance with 1.6.3.6;

.4 for tank bulkheads (except lubricating oil tanks), the web and face plate thickness of girders and of their brackets and stiffeners shall not be less than required by Formula (2.7.4.1-2); for tanker bulkheads in way of cargo and ballast tanks, this thickness shall not be less than that required by 3.5.4.

2.7.4.4 In compartments intended for the carriage of liquid cargoes and ballast, the scantlings of members of wash bulkheads and wash plates shall comply with the following additional requirements:

.1 in the wash bulkheads, the total area of openings shall not be greater than 10 % of the bulkhead area as a whole. The number and size of openings in the top and bottom strakes shall be as small as possible.

The thickness and breadth of the top and bottom plates of wash bulkheads shall comply with the requirements for the bulkhead plating of tanks or cargo (ballast) tanks proceeding from the purpose;

.2 a wash plate shall be stiffened by framing complying with the requirements for wash bulkhead framing.

The free edge of the wash plate shall be stiffened by a horizontal stiffener or a face plate. Their section modulus shall comply with the requirements for the primary members of wash bulkheads.

Where a wash plate serves as the undeck girder, it shall comply with the requirements of am 2.6.

2.7.4. The scantlings of partial bulkhead members shall comply with the following requirements:

.1 the thickness of partial bulkhead plating shall not be less than that required by Formula (2.7.4.1-1);

.2 partial bulkhead stiffeners supporting deck transverses and hatch end beams shall be in accordance with the requirements for relevant pillars (refer to 2.9).

In any case, the Euler stresses, in MPa, in a stiffener, to be determined in accordance with 2.9.4.1, shall not be less than:

$$\sigma_e = 200\eta. \quad (2.7.4.5.2)$$

The moment of inertia and sectional area of the stiffener on the basis of which the Euler stresses therein are determined shall be calculated with regard for the face plate of partial bulkhead plating equal in width to half the distance between the stiffeners;

.3 if the partial bulkhead takes up the load directly from cargo, the scantlings of its members shall comply with the requirements for hold bulkheads with regard for the particular cargo.

2.7.4.6 The scantlings of shaft tunnel members, its recess included, and those of the tight bulkheads of log and depth sounder wells, escape trunks, etc. shall comply with the requirements for the scantlings of watertight bulkhead members.

If the shaft tunnel passes through a compartment intended for the carriage of liquid cargo or ballast, the scantlings of its members shall comply with the requirements for the scantlings of the members of tight bulkheads bounding the compartment.

If the top plating is well curved, the thickness may be reduced by 10 %.

Under hatchways the top plating thickness shall be increased by 2 mm.

2.7.5 Special requirements.

2.7.5.1 The breadth of the bottom strake of bulkhead, as measured from inner bottom plating, or, where double bottom is omitted, from the bottom shell, shall be not less than 0,9 m for ships of 40 m and greater in length, and not less than 0,4 m for ships of 12 m in length. For intermediate ship lengths, the breadth of this strake shall be determined by linear interpolation. If the double bottom extends to the bulkhead on one side only, the bottom strake of bulkhead plating shall extend for at least 0,3 m above the inner bottom plating.

In the boiler room, the bottom strake of the bulkhead shall extend for at least 0,6 m above the flooring.

The upper edge of bottom strake of transverse bulkheads in the cargo tanks of tankers shall be at least 100 mm above the upper toes of brackets of bottom longitudinal. The top and bottom strake breadth of longitudinal bulkhead plating shall not be less than 0,1D, but need not exceed 1,8 m.

2.7.5.2 Cofferdams and the bulkheads forming their boundaries shall comply with the following requirements:

.1 unless expressly provided otherwise in the other Parts of the Rules, the breadth of vertical cofferdams stipulated under 2.4.7, Part VI "Fire Protection", 4.3.4 Part VII "Machinery Installations" and 13.7.5, 14.5.2, 17.3 Part VIII "Systems and Piping" shall be equal to one spacing, but not less than 0,6 m, and the height of horizontal cofferdams shall not be less than 0,7 m.

In any case, cofferdam dimensions shall be so selected as to make the cofferdams accessible for inspection and repair.

Instead of cofferdams, cofferdam bulkheads may be fitted in accordance with 3.3 unless expressly provided otherwise by the Rules;

.2 cofferdams adjoining cargo tanks and fuel tanks shall be watertight.

Bulkheads separating cofferdams from tanks shall comply with the requirements for the bulkheads of those tanks.

The bulkheads of cofferdams filled with water shall comply with the requirements for tank bulkheads.

The bulkheads of cofferdams which shall ensure tightness, but which are not filled with water, shall comply with the requirements for watertight bulkheads.

The bulkheads of cofferdams which are non-tight shall comply with the requirements for partial bulkheads as stipulated under 2.7.4.5, except the requirement for vertical webs supporting deck transverses and hatch end beams. They may have openings provided the corners of the openings are rounded and the edges are suitably reinforced. Such openings shall not generally be arranged in the top and bottom strakes of longitudinal bulkheads.

2.8 FORE AND AFTER ENDS

2.8.1 General and symbols.

2.8.1.1 Requirements are given in this Chapter for the following structures:

fore peak and bulb (if any),

bottom within 0,25L aft of the fore perpendicular,

side within 0,15L aft of the fore perpendicular, structures located aft of the after peak bulkhead, as well as strengthening of bottom and side forward in the region of impact pressure.

It is assumed in this Chapter that the upper boundary of the fore and after peak is formed by a tight deck or platform arranged directly above the summer load waterline.

2.8.1.2 For the purpose of this Chapter the following symbols have been adopted:

d_f – minimum design draught, in m, in way of forward perpendicular;

α_x – кут між вертикальною лінією і прямою лінією, яка з'єднує точки перетинання літньої вантажної ватерлінії та верхньої відкритої палуби з бортом судна у поперечному перерізі, який знаходиться на відстані 0,05L від носового перпендикуляра (див. рис. 2.8.1.2-1), град;

β_x – angle, in deg., between a tangent to the waterline at vertical mid-distance between the summer load waterline and weather deck on forward perpendicular, and a line parallel to the centreline at a cross section within 0,05L from the forward perpendicular (refer to Fig. 2.8.1.2-2).

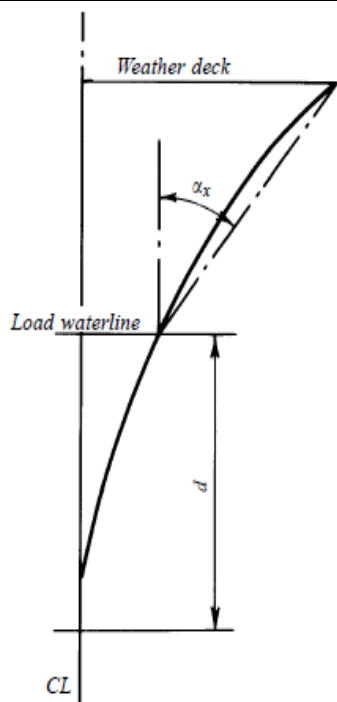

Fig. 2.8.1.2-1
Determination of angle α_x

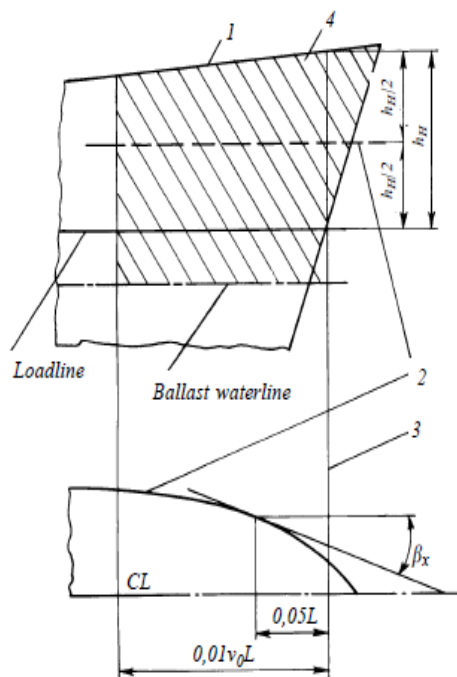

Fig. 2.8.1.2-2
Diagram for determining the angle β_x and the area (lined) to which the move impact pressure is applied:

- 1 – open upper deck;
- 2 – water line for determining the angle;
- 3 – forward perpendicular;
- 4 – impact pressure area;
- h_H – vertical distance between the loadline and the open upper deck at forward perpendicular.

2.8.2 Construction.

2.8.2.1 The following framing systems are adopted at ends:

- transverse system of framing for bottom in peaks;
- transverse or longitudinal system of framing for other structures.

Transverse or longitudinal framing for all structures shall be adopted for hulls of a pontoon shape.

2.8.2.2 Fore peak floors shall be fitted at every frame. Their height shall not be less than stipulated under **2.4.4.1**, but need not exceed 2,25 m, and the thickness shall not be less than required by Formula (2.4.4.3.1) at $k=1$ and $a=0,6$ m; however, they need not be thicker than the bottom shell plating in this region.

Floor webs shall be strengthened with vertical stiffeners to be spaced not more than 0,6 m apart. Floor face plates shall have a thickness not less than the floor thickness and a breadth required by **1.7.3.1**.

At the centreline an intercostal side girder with a face plate shall be fitted as an extension of centre girder in way of the holds. The height and thickness of girder plates as well as the thickness and width of girder face plate shall be equal to those of the floors.

Where the webs of the girder cannot be arranged, the floor face plates shall be interconnected at the centreline by an angle, tee section, etc. the flanges of which have the same width and thickness as the floor face plates. If transverse system of framing is adopted in the fore peak side, the side stringers shall be fitted at least up to the deck directly above the summer load waterline. Side stringers shall be so fitted that the distance measured vertically between them does not, in general, exceed 2 m.

Side stringers shall be supported by panting beams fitted at alternate frames and shall, where possible, be supported at the centreline by a longitudinal bulkhead.

The free edge of the side stringers shall be stiffened by a face plate having a thickness not less than that of a stringer web and a breadth in accordance with **1.7.3.1**.

At every frame, the stringer web shall be stiffened by brackets having the side dimensions not less than half the stringer web height, and where panting beams are fitted, these shall be not less than required by **1.7.2.2**. The thickness of brackets shall not be less than that of the stringer web.

Instead of panting beams, the side stringers may be supported by web frames spaced not more than 3 m apart.

It is recommended that non-tight platforms be fitted instead of side stringers with panting beams or web frames. In this case, the distance between the platforms may be increased to 2,5 m. The beams of non-tight platforms shall be fitted at every frame.

If in the structure with panting beams or web frames the distance from the base line to the nearest deck or platform exceeds 9 m, a non-tight platform shall be fitted at the middle of this length, in which the total area of openings shall not exceed 10 % of its area.

With longitudinally framed fore peak side, the spacing of web frames shall not exceed 2,4 m. Deck transverses shall be fitted in way of the web frames passage through or attachment to decks and platforms.

Floors without web frames fitted in line with them shall be attached to the nearest side longitudinals by brackets.

2.8.2.4 The bulb shall be strengthened by platforms spaced not more than 2 m apart. Beams of the platform shall be fitted at every frame.

If the length of the bulb forward of the forward perpendicular exceeds $0,03L$, a non-tight bulkhead shall be fitted at the centreline, with stiffeners arranged at every frame.

If the length of the bulb is less than $0,03L$, the bulb may be strengthened by a girder fitted at the centreline in continuation of the centre girder.

The construction of the fore end shall provide for the anchor to be lowered freely past the bulb with the ship listed 5° either side.

In way of eventual touching of the bulb, the shell plating thickness shall be increased and intermediate frames fitted.

2.8.2.5 In ships with single bottom, the bottom structure in way of the fore end outside the fore peak shall comply with the requirements of **2.3.2**, **2.3.4** and, besides, with those given below:

.1 if transverse system of framing is adopted, the spacing of side girders, as well as the distance from the centre girder or the ship's side to a side girder, shall not exceed 1,1 m within $0,25L$ from the forward perpendicular.

If longitudinal system of framing is adopted and minimum draught is less than $0,035L$ in way of the forward perpendicular, in cargo tanks of tankers an additional transverse with a face plate along its free edge shall be fitted midway between the bottom transverses. The depth of this transverse shall not be less than that of bottom longitudinals;

.2 forward of cargo tanks:

if transverse system of framing is adopted, intercostal side girders with face plates along their free edges shall be fitted in continuation of every second bottom longitudinal, extending forward as far as practicable. The depth and thickness of the side girder webs, as well as the scantlings of the face plates, shall be taken the same as for the floors;

if longitudinal system of framing is adopted, the spacing of floors shall not exceed 2,8 m. An intercostal side girder having the same scantlings as the floors shall be fitted on either side of the ship between the centre girder and longitudinal bulkhead.

2.8.2.6 In way of the fore end, the double bottom structure outside the fore peak shall comply with the requirements of **2.4.2** and those given below.

Within $0,25L$ from the forward perpendicular the distance between side girders shall not exceed 2,2 m. If transverse system of framing is adopted, in this region half-height side girders shall be fitted additionally and welded to the bottom and floors. The distance between side girders and half-height girders shall not exceed 1,1 m. These half-height girders shall be extended as far forward as practicable, whereas their free edges shall be reinforced with flanges or face plates.

If longitudinal system of framing is adopted, the floors shall be strengthened with stiffeners in line with each half-height side girder and each bottom longitudinal.

In ships greater than 80 m in length with a minimum draught less than $0,025L$ in way of the forward perpendicular, the edges of openings in floor, side girder and centre girder webs shall be stiffened within $0,25L$ from the forward perpendicular.

2.8.2.7 If transverse framing system is adopted, intercostal side stringers shall be fitted within $0,15L$ from the forward perpendicular, outside the fore peak, at the level of the fore peak side stringers.

The depth and thickness of a stringer plate shall be equal to those of the frame. The intercostal brackets fitted as stringer plates shall be welded to the webs of frames at both ends and to the shell plating. On the free edge of a stringer, a face plate shall be fitted with the thickness not less than that of the web and the breadth in accordance with 1.7.3.1.

The intercostal side stringer may be of the same profile as the frames.

The stringer face plate (flange) shall not be welded to the face plate of frame.

Intercostal stringers shall be attached to the bulkheads by brackets.

The face plates (flanges) of intercostal stringers may be omitted where the spacing of frames does not exceed their double depth. In this case, their thickness, in mm, shall not be less than:

$$s = l/4s_c + \Delta s \text{ a6o } s = 0,05h,$$

whichever is the greater,

where: l — length of the free edge of stringer between frames, in mm;

h — stringer depth, in mm;

s_c — stringer thickness, in mm, in accordance with 1.6.5.4;

Δs — value, in mm, in accordance with 1.6.5.5.

In ships having the characteristic $(v_0/\sqrt{L}) > 1,5$ or a large bow flare, provision shall be made for web frames and side stringers supported thereby. The spacing of web frames shall not exceed 5 frame spaces.

Where longitudinal framing is adopted in the ship's side forward outside the fore peak, the spacing of side transverses shall not exceed 3 m. In the holds of any ship, as well as in 'tween decks and superstructures of ships with the characteristic $(v_0/\sqrt{L}) > 1,5$ or with a large bow flare, provision shall be made for a vertical intercostal member having the same scantlings as side longitudinals, to be fitted between side transverses. The structure of the member shall be similar to that of the intercostal side stringers required by transverse framing system. The intercostal member can terminate at the upper and lower side longitudinals of the hold, 'tween decks and superstructure. Every second side longitudinal shall be attached to the side transverses by brackets extended to the frame face plate.

2.8.2.8 Within $0,1L$ from the forward perpendicular, the span of weather deck transverses shall not exceed 3 m, and the deck girder span shall not exceed 3,6 m.

Within $0,2L$ from the forward perpendicular, the section modulus of weather deck transverses shall not be less than required for deck girders with equal spans and spacing of members.

2.8.2.9 The structure located aft of the after peak bulkhead shall be sufficiently rigid in the vertical and horizontal plane. For this purpose, fitting of additional longitudinal bulkheads or platforms, thickening of deck plating and shell plating, as well as connection of bottom and upper deck longitudinals with pillars or struts may be required. If the stern overhang is large or the after peak width exceeds 20 m at any section, fitting of additional longitudinal non-tight bulkheads is recommended port or starboard.

Where there is a flat of the bottom, additional strengthening may be required to take up the loads due to impact pressure.

2.8.2.10 Floors in the after peak shall comply with the requirements of 2.8.2.2.

In single screw ships, the floors shall be extended above the stern tube, but in any case to a height of not less than 0,8 m. If this is impracticable, tie plates with face plates on both edges shall be fitted transversely at every frame above the stern tube. The thickness of the tie plates shall not be less than that of the floor. Tie plate exceeding 1,5 m in length shall be provided with a stiffener fitted in the middle of its length.

Floors with flanged edges are not permitted.

In ships greater than 200 m in length, floors shall be extended to the platform located above the stern tube. Longitudinally, the floors shall be stiffened with brackets fitted at the centreline and, if practicable, supporting the floor for a full depth. Brackets above the stern tube are necessary. The brackets shall be carried to the propeller post. They need not be fitted where a wash plate is located above the floors, with its lower edge extending at least 0,8 m below the face plates of the floors. The opening in floors for the stern tube shall be reinforced with face plate along the edges.

Below the stern tube, the openings shall be reinforced with face plates or stiffeners.

2.8.2.11 If transverse framing is adopted in the after peak side, panting beams and side stringers, beam knees, frame to side stringer attachments, arrangement and structure of web frames and non-tight platforms

shall comply with the requirements of **2.8.2.3**. The vertical distance between side stringers shall not exceed 2,5 m, and the frame span, as measured on the side plating, shall not exceed 3,5 m.

In 'twin- and multi-screw ships having a cruiser or transom stern, the distance between stringers, as measured on the side plating, shall not exceed 2 m, with one of the stringers being fitted in way of the top edge of propeller shaft bossing or in line with the shaft bracket. Where web frames are fitted, their spacing shall not exceed 2,4 m.

If longitudinal framing is adopted in the after peak side, relevant requirements of **2.8.2.3** shall be complied with.

2.8.2.12 The ends of after peak members (including deck, platform and bulkhead framing), as well as the ends of horizontal and, where practicable, vertical stiffeners of floors shall be secured (refer to **1.7.1.4**).

The face plates of the after peak floors and deck transverses shall be sniped in way of their attachments to longitudinal bulkheads.

Bulkhead stiffeners shall be attached to the floor face plates by brackets fitted on either side of the bulkhead.

This also applies to deck girder and side girder attachments to transverse bulkheads.

2.8.2.13 The spacing of ordinary and bevel frames may be the same as in the midship region, but shall not exceed 750 mm.

A side girder of the same depth as that of floors shall be fitted at the centreline. In case of transom stern and/or flat of the bottom, the side girders shall be spaced not more than 2 m apart.

In full cruiser sterns and where the frame span from the upper edge of floors to the nearest deck exceeds 2,5 m, additional strengthening shall be provided by means of web frames and a side stringer.

2.8.2.14 If peaks are used as tanks, fitting of a wash bulkhead is recommended at the centreline.

2.8.3 Loads on structures at ends.

2.8.3.1 The design pressure on the structures at ends is determined using the design loads specified in **2.2 - 2.7** and the extreme loads specified in **2.8.3.2** and **2.8.3.3**.

The scantlings of fore end members subject to impact pressure shall be verified by applying extreme loads:

- in accordance with **2.8.3.2** for ships greater than 65 m in length with a minimum draught of $0,045L$ in way of the forward perpendicular;
- in accordance with **2.8.3.3** for ships having the characteristic $(v_0/\sqrt{L}) > 1,5$ or a considerable bow flare.

2.8.3.2 Under the wave impact upon the bottom of the fore end, the extreme values of the design hydrodynamic pressure p_{SL} , in kPa, shall be determined by the formula:

$$P = 5,5c_1c_2 \varphi_r (b_x/B)(1-5d_f/L) \times (1-x_1/l_b) \cdot 10^3, \quad (2.8.3.2-1)$$

where: $c_1 = \sqrt{L}$ for $L \leq 200$ m;

$c_1 = 5\sqrt{(10-L/100)}$ for $L > 200$ m;

$c_2 = 0,07 v_0 (1-17,1 d_f/L) / \sqrt{L}$;

$l_b = (0,22 + 1,5c_2)L$,

v_0 – refer to **1.1.3**;

φ_r – as obtained from **1.3.1.5** (for ships of unrestricted service $\varphi_r = 1$);

b_x – ship breadth, in m, in the considered cross section at the level of $0,04B$ above the base line, but not greater than $0,8B$;

x_1 – distance, in m, from the considered cross section to the forward perpendicular, but not greater than l_f ;

d_f – smallest estimated draft at the forward perpendicular.

Formula (2.8.3.2-1) is used for derivation of p values in a number of sections within the portion l_b , from which the maximum value of p (hereinafter - symbol p_{max}) and the value of x_1 (hereinafter - symbol x_{max}) corresponding to p_{max} are chosen.

The design pressure p_{SL} (refer to Fig. 2.8.3.2) is determined by the formula:

$$p_{SL} = p_H + (p_{max} - p_H) x_1 / (x_{max} - 0,05L), \text{ when } 0 \leq x_1 < x_{max} - 0,05L;$$

$$p_{SL} = p_{max}, \text{ when } x_{max} - 0,05L \leq x_1 \leq x_{max} + 0,05L;$$

$$p_{SL} = p_{\max}(0,5L - x_1)/(0,45L - x_{\max}), \quad \text{when } x_{\max} + 0,05L \leq x_1 \leq 0,5L. \quad (2.8.3.2-2)$$

where: $p_H = 0,5p_{\max}$ – with bulb;
 $p_H = 0$ – without bulb.

The hydrodynamic pressure as determined by Formula (2.8.3.2-2) is distributed over a height of $0,04B$ above the base line.

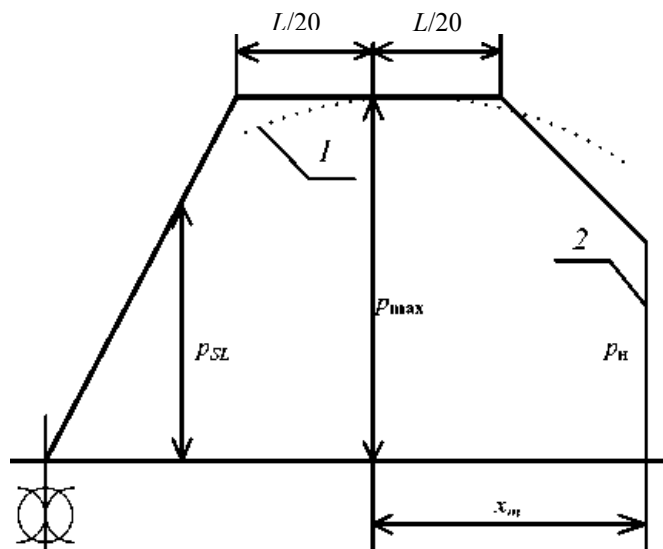

Fig.2.8.3.2 Determination of design pressure p_{SL} .

1- value of p determined by Formula (2.8.3.2-1);
 2- forward perpendicular.

2.8.3.3 Under the wave impact upon the side at the fore end, the extreme values of the design hydrodynamic pressure p_{SL} , in kPa, shall be determined by the formula:

$$p_{SL} = 0,9 c_3 c_4^2, \quad (2.8.3.3)$$

where: $c_3 = 2,2 + 1,5 \operatorname{tg} \alpha_x$;
 $c_4 = [v_0 \cdot (0,6 - 20/L) \cdot (1,2 - 0,2\beta_x/60) \cdot \sin \beta_x] + 0,6\sqrt{L}$;
 for v_0 – refer to 1.1.3;
 α_x, β_x – as defined in 2.8.1.2.

Depthwise the impact pressure is distributed over the part of the side above the ballast waterline, and lengthwise - over the part of the side extending as far aft as the cross section at $0,01v_0L$ from the forward perpendicular and as far forward as the intersection of the upper deck with the stem (refer to Fig. 2.8.1.2-2).

2.8.4 Scantlings of structural members at ends.

2.8.4.1 The shell plating thickness, scantlings of single bottom and double bottom members and of side framing shall comply with the requirements of 2.2.4, 2.3.4, 2.4.4, 2.5.4 using the service loads given in 2.2, 2.3, 2.4, 2.5. Besides, when determining the scantlings of fore and after peak members, the following requirements shall be satisfied:

.1 the section modulus of frames shall be determined by Formulae (1.6.4.1) and (1.6.4.2) taking:

$m = 12$;

- l – spacing of side stringers, as measured along the shell plating;
.2 scantlings of panting beams shall comply with the requirements of **2.9.4.1**;
.3 in calculating the section modulus and cross-sectional area of web frames:
 $m = 10$;

$$N_{\max} = 0,5pal, \text{ in kN,}$$

(2.8.4.1.3)

where: p – design pressure, in kPa, according to **2.5.3**;
 a – spacing of web frames, in m;

l – span of web frame, in m, as measured between the upper edge of floor and the deck (platform) bounding the fore peak (after peak) or the non-tight platform, if any, nearest to the bottom, or between non-tight platforms, the deck and non-tight platform less the height of deck transverse of the relevant deck (platform);

.4 plating thickness and framing of non-tight platform shall satisfy the requirements of 2.6.4 for platforms at ends. When determining the design load by Formula (1.3.4.1), the product $h\rho_c g$ shall not be less than 3,5 kPa.

The thickness of non-tight platform plating, in mm, shall not be less than:

$$s_{\min} = (0,02L + 5)\sqrt{\eta}, \quad (2.8.4.1.4)$$

but not less than 5 mm.

Where $L > 300$ m, L shall be taken equal to 300 m;

.5 if the fore peak (after peak) is used as tanks, the scantlings of their members shall also comply with the requirements for the structural members of tanks.

2.8.4.2 Where exposed to extreme loads to be determined in accordance with **2.8.3.2**, the scantlings of bottom framing members at the fore end shall comply with the requirements of **2.2.4**, **2.3.4** and **2.4.4**, as well as with the following additional requirements:

.1 the thickness of shell plating shall be determined by Formula (1.6.4.4) taking

$$p = 0,4p_{SL}, \quad (2.8.4.2.1)$$

where: p_{SL} – as determined by Formula (2.8.3.2-2);

$$m = 15,8;$$

$$k_{\sigma} = 0,7;$$

.2 the section modulus, in cm^3 , of a primary member shall not be less than:

$$W = 0,75pal^2\omega_c \cdot 10^3 / (mk_{\sigma}\sigma_n), \quad (2.8.4.2.2)$$

where: p – as determined by Formula (2.8.4.2.1);

$$k_{\sigma} = 0,65;$$

$m = 16$, if the members are continuous through the webs of supporting structures;

$m = 8$, if the members are cut at supports;

$m = 28$, if the supporting sections of the member are reinforced with brackets on both sides of the supporting structure; the depth and length of brackets are not less than 1,5 of the member depth;

for ω_c – refer to **1.1.5.3**;

.3 the cross-sectional area f , in cm^2 , of a primary member or of welds by which intercostal members are connected to supporting structures shall not be less than:

$$f = [5pal \cdot (l - 0,5a) / (k_{\tau}\tau_n)] + 0,05\sum h_i\Delta s, \quad (2.8.4.2.3)$$

where: p – as determined by Formula (2.8.4.2.1);

$$k_{\tau} = 0,65;$$

$\sum h_i$ – length of member section perimeter, in cm;

Δs – as obtained from **1.1.5.1**.

The cross-sectional area of a member includes the web area, as well as the portion of the sectional area of shell plating, having a breadth $b_1 = 3s$ (where s is the thickness, in mm, of shell plating).

If the member is of bulb profile, the whole of its face plate is included in the cross-sectional area. In the case of member of T-section, a portion of its breadth $b_2 = 3s_{f,p}$ (where $s_{f,p}$ – is the face plate thickness of the member, in mm);

.4 the web thickness s , in mm, of floor, side girder and centre girder shall not be less than:

$$s = [0,75pab/(k_{\tau}\tau_n h)] + \Delta s, \quad (2.8.4.2.4)$$

where: p – as determined by Formula (2.8.4.2.1);

$k_{\tau} = 0,65$;

h – depth, in m, of floor, side girder or centre girder accordingly;

a and b – average spacing of floors and girders accordingly (centre girder and side girder); when determining b , half-height side girders shall be disregarded;

Δs – as obtained from 1.1.5.1.

2.8.4.3 Where exposed to extreme loads to be determined in accordance with 2.8.3.3, the scantlings of side framing members at the fore end shall comply with the requirements of 2.2.4 and 2.5.4, as well as with the following additional requirements:

.1 the thickness of shell plating shall be determined by Formula (1.6.4.4) taking:

$$p = 0,4p_{SL}, \quad (2.8.4.3.1)$$

where: p_{SL} – as determined by Formula (2.8.3.3);

$m = 15,8$;

$k_{\sigma} = 0,7$;

.2 the section modulus of a primary member shall comply with the requirements of 2.8.4.2.2 using the design load determined by Formula (2.8.4.3.1);

.3 the section modulus of a primary member shall comply with the requirements of 2.8.4.2.3 using the design load determined by Formula (2.8.4.3.1).

2.8.4.4 Within the area of the stern counter, the scantlings of frames shall be not less than those of the after peak frames, unless their span exceeds 2,5 m. With a greater span, the frame scantlings shall be increased accordingly. The thickness of floors and side girders shall not be less than required by 2.8.4.5.

2.8.4.5 The side stringers of fore and after peaks shall have a web sectional area f_c , in cm^2 , not less than

$$f_c = 0,45L + 12. \quad (2.8.4.5-1)$$

The side stringer width b , in m, shall not be less than:

$$b = 0,005L + 0,24, \quad \text{for } L \leq 80 \text{ m}; \quad (2.8.4.5-2)$$

$$b = 0,003L + 0,4, \quad \text{for } L > 80 \text{ m}.$$

The web thickness, in mm, of a side stringer shall not be less than

$$s = (0,02L + 5) \cdot \sqrt{\eta}, \quad (2.8.4.5-3)$$

but not less than 5 mm.

Where $L > 300$ m, L shall be taken equal to 300 m.

2.8.4.6 The thickness of shell plating in way of the bulb shall not be less than $0,08L+6$, but it need not be taken greater than 25 mm. In this case, the shell plating thickness at the lower part of the bulb shall not be less than stipulated under 2.8.4.2.1 for the hull section in way of the forward perpendicular.

2.8.5 Special requirements.

2.8.5.1 Visor-type bow doors.

2.8.5.1.1 The present requirements apply to the construction of visor-type bow doors which form a component part of the fore end of the ship, being mechanically connected with the side and deck structures

and capable of moving in the vertical direction to provide access for motor vehicles and/or other transport means.

2.8.5.1.2 The thickness of visor-type bow door plating shall not be less than that required by **2.8.4** for the appropriate sections of shell plating.

2.8.5.1.3 The section modulus of primary members shall not be less than that required by 2.8.4 for the appropriate fore end regions.

In this case, the design load, in kPa, shall not be less than:

$$p_{\min} = 0,8(1,5v_0 + 0,6\sqrt{L})^2. \quad (2.8.5.1.3-1)$$

The sectional area of member web shall not be less than determined by Formula (1.6.4.3-1) taking:

$$N_{\max} = 0,5pal, \text{ in kN}, \quad (2.8.5.1.3-2)$$

where: p – design load in accordance with 1.3.2.2 or 2.8.3.3, whichever is the greater, but not less than p_{\min} , in kPa, as determined by Formula (2.8.5.1.3-1);

$$k_{\tau} = 0,7.$$

2.8.5.1.4 Structural measures shall be taken to ensure rigid attachment of primary members and support members of bow doors.

2.8.5.1.5 The scantlings of support members shall be obtained by strength calculation using the design loads given in 1.3.2.2 or 2.8.3.3, whichever is the greater, but not less than p_{\min} determined by Formula (2.8.5.1.3-1), as well as the permissible stress factors $k_{\sigma} = k_{\tau} = 0,6$.

2.8.5.1.6 The construction of support members shall comply with the requirements of **1.7.3**.

2.8.5.2 In ships provided with fixed propeller nozzles, transverse bulkheads or support members shall be fitted in way of the nozzle attachment to the hull.

2.8.5.3 In hull curvilinear sections (deadrise, flare), it is recommended that the framing be fitted at an angle of approximately 90° to the shell plating.

2.9 PILLARS AND PANTING BEAMS

2.9.1 General and symbols.

2.9.1.1 Requirements are given in this Chapter for the scantlings of pillars fitted in the hull, superstructures and deckhouses and for the panting beams in peaks.

2.9.1.2 For the purpose of this Chapter the following symbols have been adopted:

l – length of pillar (panting beam), in m, measured:

for the pillar – between the face plate of the deck girder (or the deck transverse, if the latter is supported by the pillar) and the deck plating (or the inner bottom plating);

for the panting beam – between the inner edges of the starboard and port frames or from the inner edge of the frame to a strong support at the centerline;

f – sectional area of the pillar (panting beam), in cm²;

i – the least moment of inertia of the pillar (panting beam), in cm⁴;

d_0 – outer diameter of the pillar, in mm.

2.9.2 Construction.

2.9.2.1 The pillar axes in 'tween deck spaces and holds shall generally be fitted in the same vertical line, the heads and heels of the pillars shall be bracketed.

Where the heel of a tubular pillar with the load $P < 250$ kN has no brackets, the deck (inner bottom) plating under the heel shall be strengthened with doubling or insert plates (P = as determined from **2.9.3.1**).

The web of a framing member to which the head of a pillar is attached shall be strengthened with brackets to transmit the load to the pillar.

The pillars shall be fitted on plate floors and side girders which shall be strengthened with vertical brackets. Openings in floors and side girders under the pillars are not permitted.

With the load $P > 250$ kN (P = as defined in 2.9.3.1), the pillars shall be fitted at the intersection of plate floors and side girders, otherwise the plate floor (side girder) shall be strengthened with vertical brackets attached to the adjacent floors (side girders).

2.9.2.2 The pillars shall be attached at their heads and heels by brackets or other arrangements, in order to effectively transmit the loads to the hull structures below:

in the holds of ships of ice classes **Ice6** and **Ice5**;

in the tanks under watertight platforms, deckhouses, ends of superstructures, windlasses, winches, capstans, etc.;

at the fore end of ships with the specified speed $v_0 > 1,5\sqrt{L}$ (for v_0 – refer to **1.1.3**) or large bow flare.

2.9.3 Design loads.

2.9.3.1 Loads on the pillar P , in kN, is determined by the formula

$$P = pl_m b_m + \sum_i (pl_m b_m)_i, \quad (2.9.3.1)$$

where: p – design pressure on the above deck specified in **2.6.3**, in kPa;

l_m – distance measured along the deck girders between mid-points of their spans, in m;

b_m – mean breadth of deck area (including the hatchways in the region concerned) supported by the pillar, in m;

$\sum_i (pl_m b_m)_i$ – sum of loads from the pillars fitted above, determined having regard to **2.6.3**, which may be

transmitted to the pillar considered, in kN.

2.9.3.2 Loads on the panting beam P , in kN, is determined by the formula

$$P = pac, \quad (2.9.3.2)$$

where: $p = p_{st} + p_w$ – design pressure on the ship's side in way of installation of the panting beam, determined from **1.3.2.1** and **1.3.2.2**, in kPa;

a – spacing of frames on which panting beams are fitted, in m;

c – half-sum of frame spans measured vertically above and under the beam considered, in m.

2.9.4 Scantlings of pillars and panting beams.

2.9.4.1 The sectional area of pillars and panting beams f , in cm^2 , shall not be less than determined by the iterative method according to the formula

$$f = 10Pk / \sigma_{cr} + \Delta f, \quad (2.9.4.1)$$

where: P – as determined in accordance with **2.9.3**;

$k = 2$ – buckling strength margin;

σ_{cr} – critical stress according to **1.6.5.3** at Euler stress determined by the formula:

$$\sigma_e = 206 i / fl^2;$$

Δf – wear allowances, in cm^2 , determined by the following formulae:

for tubular pillars

$$\Delta f = 0,03d_0\Delta s;$$

for box-shaped pillars

$$\Delta f = 0,1\sum h_i \Delta s,$$

where: $\sum h_i$ – perimeter length of cross section, in cm;

Δs – refer to **1.1.5.1**;

i, f, l, d_0 – refer to **2.9.1.2**.

2.9.4.2 The wall thickness s , in mm, of tubular pillars shall not be taken less than

$$s = (d_0/50) + 3,5. \quad (2.9.4.2-1)$$

The wall thickness of built-up pillars (box-shaped, made of channels or I-beams, etc.) s , in mm, shall not be less than

$$s = h_p/50, \quad (2.9.4.2-2)$$

where: h_p – width of the pillar wall, in mm.

The wall thickness of a pillar, in general, shall not be taken less than 6 mm.

In small ships the thickness of the pillar walls may be reduced to 5 mm, provided the required sectional area of the pillar is maintained.

2.9.4.3 The thickness of insert plate under the lower end of pillar (refer to **2.9.2.1**) s , in mm, shall not be taken less than

$$s = 3,3P \cdot 10^{-3} + 10, \quad (2.9.4.3)$$

where: P – as defined in **2.9.3.1**.

The diameter of the insert plate shall exceed the diameter of the pillar by $\approx 6s$.

2.10 STEMS, KEELS, RUDDER HORN, PROPELLER SHAFT BRACKETS, FIXED NOZZLES OF PROPELLER

2.10.1 General.

Requirements are given in this Chapter for the construction and scantlings of the stem, sternframe (rudder post, propeller post), solepiece of the sternframe, rudder horn of semi-spade rudders, propeller shaft brackets, bar keel, fixed nozzles of propellers.

2.10.2 Construction.

2.10.2.1 It is recommended to use a bar or plate type welded stem. The lower part of the stem shall be efficiently connected to the bar or plate keel and, whenever possible, to the centre girder.

The welded stem plates shall be stiffened with transverse brackets. Arrangement of transverse brackets of the stem shall, as far as possible, be consistent with the hull framing. Transverse brackets stiffening the stem plate are fitted not more than 1 m apart below and not more than 1,5 m above the summer load waterline. The brackets shall overlap the joints of the stem with the shell plating and shall be extended and welded to the nearest frames.

The brackets which cannot be extended to the framing, except for the brackets in way of ice belt in ships with ice categories, shall have their rear edge made along a smooth curve.

In case where the radius of curvature of the stem is sufficiently large, it is recommended to fit a centerline girder with a face plate.

2.10.2.2 The construction of sternframe of a single screw ship shall comply with the following requirements:

.1 the solepiece shall be made with a smooth rise in the aft direction;

.2 the propeller post shall be provided with transverse brackets in the case of welded sternframe and webs in the case of cast sternframe. The brackets and webs shall be spaced at least 1 m apart; their arrangement shall be consistent with the hull framing;

.3 the sternframe shall be efficiently attached to the hull.

The lower part of the sternframe shall be extended forward from the propeller post and shall be attached by its brackets (webs) to at least three floors in ships with a length $L > 120$ m and at least two floors in ships with a length $L \leq 120$ m.

In small ships the sternframe may be attached to one floor only.

The rudder post shall extend over the counter to a height sufficient for its attachment to the transom floor. In ships of 80 m and above and in ships with cruiser stern, the propeller post shall also be extended upwards to a distance sufficient for its attachment to the additional transom floor.

The thickness of transom floor and additional transom floor shall be increased as compared to that of the floors in the after peak. In general, the above floors shall be extended to the nearest deck or platform.

2.10.2.3 The sternframe in twin screw ships shall comply with the requirements for the sternframe in single screw ships, as specified in **2.10.2.2**.

The lower part of the sternframe to be extended forward, may be attached to at least two main floors.

2.10.2.4 The sternframe of triple screw ships shall comply with the requirements for the sternframe of single screw ships, as specified in **2.10.2.2** and **2.10.4.2**.

2.10.2.5 The rudder horn of semi-spade rudder shall be efficiently connected to the respective floors of the after peak and its centreline wash bulkhead.

The welded rudder horn shall be provided inside with transverse brackets; its main supporting structures shall be extended to the nearest deck or platform; the thickness of the floors to which the rudder horn is connected shall be increased as compared to that of the floors in the after peak.

2.10.2.6 The struts of two-strut shaft brackets shall form an angle not less than 50° to each other.

2.10.2.7 The outer and inner plating of propeller nozzle shall be strengthened by stiffeners whose arrangement and size as well as connection with outer and inner plating of the propeller nozzle shall be determined according to **2.4.2.2**, Part III "Equipment, Arrangements and Outfit".

In general, the transverse web plates shall be arranged in line with the floors of the after peak.

In way of attachment of the nozzle to the hull smooth transition from the nozzle to the ship's hull shall be provided. The bottom part of the nozzle shall be connected to the hull. If the propeller nozzle is attached to the hull by shaft brackets, provision shall be made for an efficient connection of the brackets with the framing in the aft region of the hull and the framing inside the nozzle.

The construction of shaft brackets shall satisfy the requirements of **2.10.2.6**.

Drain plugs of non-corrosive material shall be fitted in the top and bottom parts of outer plating.

2.10.3 Design loads.

Design loads for the structures of the solepiece and rudder horn of semi-spade rudders is taken equal to the reaction force of lower support of the rudder R_4 according to **2.2.4.12**, Part III "Equipment, Arrangements and Outfit". In the Formulae (2.2.4.7-2) - (2.2.4.7-4) the coefficient α_4 shall be taken equal to zero.

2.10.4 Scantlings of stem, sternframe, rudder horn and propeller shaft brackets, bar keel and fixed nozzle of propeller.

2.10.4.1 The stem shall satisfy the following requirements:

.1 the sectional area f , in cm², of a bar stem from the keel to the summer load waterline shall not be less than

$$f = 1,3L - 4. \quad (2.10.4.1.1)$$

The sectional area may be reduced for ships of restricted areas of navigation:

R2, A-R2, R2-S, R2-RS, A-R2-S, A-R2-RS, B-R3-S and **B-R3-RS** (refer to **1.6.4.6**) – by 10%;

B-R3-S i **B-R3-RS** (refer to **1.6.4.6**), **C-R3-S, C-R3-RS, R3-S, R3-RS, R3, R3-IN, D-R3-S, D-R3-RS** – by 20%.

Above the summer load waterline the sectional area may be gradually reduced to 70 % of the area stated above;

.2 the plate thickness s , in mm, of welded stem shall not be less than

$$s = (0,085L + 5,5)\sqrt{\eta}, \quad (2.10.4.1.2)$$

where: η – as determined from **1.1.4.3**,

but not less than 7 mm.

Where $L > 220$ m, L shall be taken equal to 200 m;

The plate thickness of the stem may be reduced for ships of restricted areas of navigation:

R2, A-R2, R2-S, R2-RS, A-R2-S, A-R2-RS, B-R3-S and **B-R3-RS** (refer to **1.6.4.6**) – by 5%;

B-R3-S i **B-R3-RS** (refer to **1.6.4.6**), **C-R3-S, C-R3-RS, R3-S, R3-RS, R3, R3-IN, D-R3-S, D-R3-RS** – by 10%.

The plate thickness of the stem above the summer load waterline may be gradually reduced to that of shell plates adjoining the stem.

The thickness and width of the stem plates in way of attachment to the plate keel shall not be less than the thickness and width of the latter.

When the distance between the brackets strengthening the stem is reduced by 0,5 m, as compared to that required by **2.10.2.1**, the reduction of plate thickness of stem by 20 % may be permitted.

If the reduction of the distance between the brackets is less than 0,5 m, the permissible reduction of plate thickness shall be determined by linear interpolation;

.3 the thickness of brackets strengthening the stem shall not be less than that of shell plating adjoining the stem. The thickness of web and face plate of the girder stiffening the stem at the centreline shall not be less than that of the brackets.

2.10.4.2 The sternframe of a single screw ship shall satisfy the following requirements:

.1 the length l_s and width b_s , in mm, of rectangular solid propeller post section, from the keel to the counter, shall not be less than

$$l_s = 1,30L + 95; \quad b_s = 1,60L + 20, \quad \text{for } L < 120 \text{ m}; \quad (2.10.4.2.1)$$

$$l_s = 1,15L + 110; \quad b_s = 0,675L + 130, \quad \text{for } L \geq 120 \text{ m}.$$

The thickness of webs shall be at least 50 % greater than that of the shell plating adjoining the sternframe:

R2, A-R2, R2-S, R2-RS, A-R2-S, A-R2-RS, B-R3-S and **B-R3-RS** (refer to 1.6.4.6) – by 5%;

B-R3-S and **B-R3-RS** (refer to 1.6.4.6), **C-R3-S, C-R3-RS, R3-S, R3-RS, R3, R3-IN, D-R3-S, D-R3-RS** – by 10%.

Above the counter the sectional area of sternframe may be gradually reduced. And nowhere its sectional area shall be less than 40 % of the required area of the propeller post, corresponding to the scantlings stated above (2.10.4.2.1);

.2 the scantlings of the propeller post cross section of a cast sternframe with the rudder having top and bottom supports shall be established in accordance with Fig. 2.10.4.2.2 depending on the value s_0 , in mm, determined by the following formulae:

$$s_0 = 0,1L + 4,4, \quad \text{for } L < 200 \text{ m}; \quad (2.10.4.2.2)$$

$$s_0 = 0,06L + 12,4, \quad \text{for } L \geq 200 \text{ m}.$$

The thickness of webs shall be at least 50 % greater than that of the shell plating adjoining the sternframe;

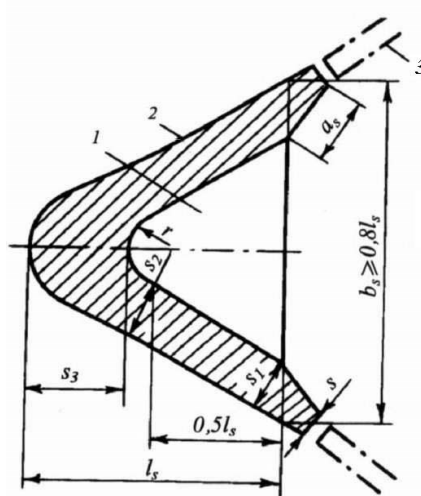

Fig. 2.10.4.2.2

1 – web; 2 – along the hull shape; 3 – adjoining plate of shell;

$$s_1 = 1,5s_0; \quad s_2 = 2,5s_0; \quad s_3 = 3,5s_0;$$

$$l_s \geq 1,9L + 135 \text{ mm} \quad \text{for } L < 200 \text{ m};$$

$$l_s \geq 1,4L + 235 \text{ mm} \quad \text{for } L \geq 200 \text{ m};$$

r – cast radius.

.3 the scantlings of the propeller post cross section of a welded sternframe with the rudder having top and bottom supports shall be established according to Fig. 2.10.4.2.3 where s_0 shall be determined in accordance with 2.10.4.2.2.

The thickness of transverse brackets shall be at least 20 % greater than that of the shell plating adjoining the sternframe.

Welded propeller post of other construction may be used, provided that its strength is equivalent to that of the abovementioned construction;

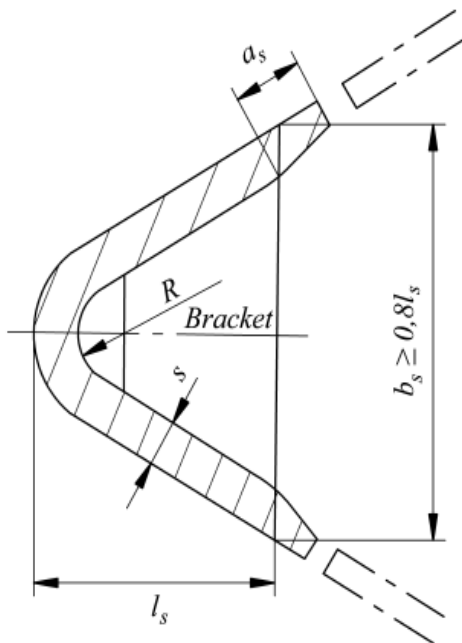

Fig.2.10.4.2.3:

$$s = 1,65s_0 \text{ for } L < 150 \text{ m;}$$

$$s = 1,5s_0 \text{ for } L \geq 150 \text{ m;}$$

$$l_s = 2,5L + 180 \text{ mm for } L < 200 \text{ m;}$$

$$l_s = 1,4L + 400 \text{ mm for } L \geq 200 \text{ m;}$$

R – bending radius.

.4 the finished thickness of propeller boss shall be not less than 30 % of the shaft diameter;

.5 the section modulus W_s , in cm^3 , of the solepiece about the vertical axis shall not be less than

$$W_s = 8\alpha R_4 x_s \eta. \quad (2.10.4.2.5-1)$$

The section modulus $W_{r,p}$, in cm^3 , of the rudder post about the horizontal longitudinal axis shall not be less than

$$W_{r,p} = 8(1-\alpha) R_4 l_p \eta. \quad (2.10.4.2.5-2)$$

where: $\alpha = 0,85$ if there is a rudder post;

$\alpha = 1,0$ if there is no rudder post or a bolted rudder post is fitted;

x_s – distance from the solepiece section concerned to the centre of the rudder stock (x_s shall not be taken less than $0,5l_s$ and more than l_s);

R_4 – as determined according to **2.10.3**;

l_s – span of the solepiece, measured from the centre of the rudder stock to the beginning of rounding of the propeller post, in m;

$l_{r,p}$ – span of the rudder post, measured vertically from the mid-thickness of solepiece at the centre of the rudder stock to the beginning of rounding in the upper part of the rudder post, in m;

η – as determined according to **1.1.4.3**.

The section modulus of the solepiece about the horizontal transverse axis shall not be less than $0,5 W_s$ where W_s shall be determined by Formula (2.10.4.2.5-1).

The section modulus of the rudder post about the horizontal transverse axis shall not be less than $0,5 W_{r,p}$ where $W_{r,p}$ shall be determined by Formula (2.10.4.2.5-2);

.6 the scantlings of the sternframe structural members may be determined on the basis of direct strength calculation taking the permissible stress factor $k_\sigma = 0,55$ and external loads according to **2.2**, Part III "Equipment, Arrangements and Outfit".

2.10.4.3 The scantlings of the sternframe of twin screw ships shall satisfy requirements for the scantlings of propeller post in single screw ships as given in **2.10.4.2** with the following amendments:

.1 the section width of the sternframe of a solid rectangular cross section may be reduced by 50 % as compared with that required by **2.10.4.2.1**;

.2 the scantlings of the cast or welded sternframe may be reduced as compared with those required by **2.10.4.2.2** and **2.10.4.2.3** respectively, so that their section moduli about the horizontal longitudinal and transverse axes, are reduced by not more than 50 %. The thickness of the sternframe wall shall be at least 7 mm.

2.10.4.4 For semi-spade rudders with one gudgeon upon the horn, the section modulus, in cm^3 , of the rudder horn about the horizontal longitudinal axis shall not be less than

$$W = 12R_4 z_s \eta. \quad (2.10.4.4)$$

where: R_4 – as defined in to **2.10.3**;

z_s – vertical distance for the mid-thickness of the horn gudgeon to the section concerned, in m (z_s shall not be taken less than $0,5l_h$ and more than l_h);

l_h – horn span measured vertically from the mid-thickness of the horn gudgeon to the point of intersection of the horn axis with shell plating, in m;

η – as determined according to **1.1.4.3**.

Where the rudder horn is welded of plates, the thickness of the plates, in all cases, shall be at least 7 mm.

The scantlings of the rudder horn may be determined on the basis of direct strength calculation taking the permissible stress factor $k_\sigma = 0,35$ and external loads according to **2.2**, Part III "Equipment, Arrangements and Outfit".

2.10.4.5 The sectional area of either strut of two-strut shaft brackets shall be equal to not less than 60 % of the propeller shaft section in the bracket plane, the strut thickness – to not less than 45 %, and the boss thickness – to not less than 35 % of the propeller shaft diameter.

The length of the boss shall be in accordance with 5.6.1, Part VII "Machinery Installations".

The strength of the welded shaft brackets shall not be less than that specified above. The plate thickness shall not be less than 7 mm.

The weld area of rivets attaching each strut to the hull shall not be less than 25 % of the propeller shaft sectional area. Where the struts are attached by means of flanges, the thickness of the latter shall be not less than 25 % of the propeller shaft diameter.

2.10.4.6 The height h_s and width b_s in mm, of the bar keel cross section shall not be less than:

$$\begin{aligned} h_s &= 1,3L + 100; \\ b_s &= 0,7L + 8, \quad \text{for } L < 60 \text{ m}; \\ b_s &= 0,4L + 26, \quad \text{for } L \geq 60 \text{ m}. \end{aligned} \quad (2.10.4.6)$$

The height and width of the bar keel cross section may be reduced for ships of restricted areas of navigation:

R2, A-R2, R2-S, R2-RS, A-R2-S, A-R2-RS, B-R3-S and B-R3-RS (refer to **1.6.4.6**) - by 5%;

B-R3-S and B-R3-RS (refer to **1.6.4.6**), **C-R3-S, C-R3-RS, R3-S, R3-RS, R3, R3-IN, D-R3-S, D-R3-RS** - by 10%.

2.10.4.7 The thickness of outer and inner plating of fixed propeller nozzle shall comply with the requirements of **2.4.2**, Part III "Equipment, Arrangements and Outfit" taking the following into consideration:

width of middle belt of inner plating shall be not less than the distance from $0,03 D_o$ forward of the propeller blade tips and $0,07D_o$ aft of the propeller blade tips where D_o is the internal diameter of propeller nozzle;

thickness of forward part of the inner and outer plating shall be not less than required for side shell plating (refer to **2.2.4.1** for transverse framing system).

The width of attachment shall be at least $0,15D_o$.

The cross-sectional area of the joint shall be not less than required by **2.10.4.2.5** for the solepiece.

For twin screw ships when the propeller nozzle is not attached to the hull at its bottom part, the width of attachment at the top part shall be not less than $0,3D_o$.

If the propeller nozzle is attached to the hull by shaft brackets, their strength shall comply with the requirements of **2.10.4.5**.

In way of attachment of the nozzle to the hull the thickness of framing members shall not be less than required by Formula (2.4.2.2-2), Part III "Equipment, Arrangements and Outfit".

2.11 SEATINGS OF MACHINERY AND BOILERS

2.11.1 General.

2.11.1.1 Requirements are given in this Chapter for the construction and dimensions of the seatings intended for main machinery and boilers, deck machinery, fishing installations, cargo handling gear, auxiliary machinery, etc.

2.11.1.2 Requirements of this Chapter are minimal. Requirements concerning construction and dimensions of structural components of a seating, which are contained in the technical documentation of the machinery, unit or device to be installed on the seating concerned, shall also be complied with.

2.11.1.3 For dimensions of the structural components of the seatings intended for mooring and towing appliances — refer to **4.3** and **5.3**, Part III "Equipment, Arrangements and Outfit".

2.11.2 Construction of seatings.

2.11.2.1 The construction of seatings shall satisfy the following requirements:

.1 the seating shall be of substantial construction to ensure efficient attachment of machinery, gear or device and transmission of forces to the hull framing, which shall be sufficiently strong. If necessary, the framing may be strengthened;

.2 the seating shall be so constructed that the resonance vibration of the seating as a whole and of its structural components can be avoided under all specified running conditions;

.3 where the seating in ships with a length $L > 65$ m is installed on the continuous longitudinals of strength deck and double bottom (bottom) within $0,5L$ amidships, the height of the vertical plates of the seating at the ends shall be gradually reduced.

If the length of the vertical plate is more than six times its height, the vertical plate and its top plate shall be made of the same steel grade as the deck or double bottom (bottom) structural member on which it is installed.

The structural components of the seating shall not terminate at the unsupported portions of plating;

.4 the seating shall be so designed that the plating beneath is accessible for inspection. Measures shall be taken to prevent water from accumulating under the seating.

2.11.2.2 In general, a seating of main machinery and boilers shall comprise two vertical plates (girder webs) (for medium-speed and high power engines — four vertical plates (two — either side of the engine)) and horizontal face plates (top plates) to which the machinery (boiler) shall be attached directly.

The vertical plates shall be strengthened with brackets (knees) having face plates (flanges) along the free edges.

Where the seating comprises four vertical plates, the top plate is attached to two vertical plates fitted on one side of the machinery; the outer plates shall have openings to provide access into the seating.

In the case of medium-speed engines, such openings shall not extend to the top plate.

The outer plates may be made sloped.

All the vertical plates shall be fitted in line with the main or additional side girders.

2.11.2.3 Machinery and equipment may be installed on shell plating of the hull, tight bulkheads, decks and platforms (including tank bulkheads and crown), inner bottom and shaft-tunnel platings on condition they are attached to the framing members and stiffeners (refer to **1.7.1.4**), or on cantilevers connected to framing members or stiffeners.

Attachment of small-sized machinery and equipment directly to the above-mentioned structure with the help of welded pads is not permitted.

2.11.3 Dimensions of structures of seatings.

2.11.3.1 The thickness s , in mm, of structural components of a seating of main machinery or boiler shall not be less than

$$s = k_0 \sqrt[3]{Q} + k_1, \quad (2.11.3.1)$$

where: Q – mass of machinery (boiler) in working condition, in t;

k_0 – factor given in Table 2.11.3.1-1;

k_1 – factor given in Table 2.11.3.1-2.

Table 2.11.3.1-1

Seating of machinery (boiler)	k_0		
	Top plates	Vertical plates ¹	Brackets, knees
Main internal combustion engine	4,65	3,0	2,5
Main geared turbine set, main diesel generator and propulsion motor	4,15	2,7	2,7
Boiler	3,65	2,4	2,4

¹In a seating with four vertical plates the thickness of the plates may be taken equal to the thickness of brackets and knees.

Table 2.11.3.1-2

Mass of machinery (boiler), in t	≤ 20	> 20 ≤ 50	> 50 ≤ 100	> 100 ≤ 200	> 200
k_1	4	3	2	1	0

2.11.3.2 The thickness s , in mm, of structural components of a seating of main internal combustion engine shall not be less than:

$$s = k_2 \sqrt[3]{N} + k_3, \quad (2.11.3.2)$$

where: N – specified power of the engine, in kW;

k_2, k_3 – factors given in Table 2.11.3.2,

Таблица 2.11.3.2

N , in kW	Number of vertical plates	Factor	Top plates	Vertical plates	Brackets, knees
≤ 1000	2	k_2	1,7	1,1	0,9
		k_3	6	4	3
	4	k_2	1,4	0,9	0,9
		k_3	5	3	3
> 1000	2	k_2	1,0	1,0	0,7
		k_3	13	5	5
	4	k_2	0,8	0,7	0,7
		k_3	11	5	5

but not less than required by 2.11.3.1.

2.12 SUPERSTRUCTURES, DECKHOUSES AND QUARTER DECKS

2.12.1 General provisions, definitions and symbols.

2.12.1.1 Requirements are given in this Chapter for short and long bridges extending from side to side of the ship as well as to short bridges which do not extend to the sides of the ship, forecastle, poop, long forecastle and poop extending to ship's sides, short deckhouses and quarter decks.

2.12.1.2 Long deck house is a deckhouse of a length not less than that determined by Formula (2.12.1.2-1), but not less than 0,20 L , having no expansion or sliding joints .

Long bridge is a superstructure having a length not less than:

$$l_1 = 2 l_e, \quad (2.12.1.2-1)$$

but not less than 0,15 L .

Quarter deck is the after part of upper deck stepped up to a portion of 'tween deck height.

Ends of superstructures and deck-houses are the ends of the length measured from the end bulkheads, in m,

$$L_e = 1,5 (B_2 / 2 + h). \quad (2.12.1.2-1)$$

Short deckhouse is any deckhouse which is not a long deckhouse.

Deckhouses of ships less than 65 m in length are considered as short deckhouses.

Short bridge is any bridge which is not a long bridge.

Superstructures of ships less than 65 m in length are considered as short superstructures.

Transition area of quarter deck – is an area measured from the forward edge of break to the after edge of upper deck plating and extending below the quarter deck.

Long forecastle (poop) is a forecastle (poop) having a length not less than

$$l_1 = 0,1L + l_e, \quad (2.12.1.2-3)$$

in ships of 65 m and greater in length

Deck step up is a stepped up or lowered part of the deck upon side depth, (may be vertical or inclined).

2.12.1.3 Symbols:

B_2 – breadth of superstructure deck measured at its mid-length, excluding the breadth of openings of cargo hatches, machinery casings, if any, in m; helicopter deck (platform), which is part of the upper deck or the superstructure or deckhouse top;

B_x – ship's breadth at the level of the upper deck at the section considered, in m;

b – breadth of the deckhouse, in m;

h – height of the first tier of superstructure or deckhouse, in m;

l_1 – length of superstructure (deckhouse) measured between the end bulkheads; the length of forecastle (poop) measured from the fore or after perpendicular to the end bulkhead of the forecastle (poop), in m;

2.12.2 Construction.

2.12.2.1 For the first tier of long bridge outside the end portions, long forecastle (poop) outside the end portion, the requirements of 2.6 for the upper deck and the requirements of 2.2 and 2.5 for the ship's side in way of the upper 'tween deck space shall be complied with.

2.12.2.2 For the bottom strake of side plating and longitudinal bulkhead plating of short bridge, the ends of 1st tier long bridges and long forecastle (poop), the bottom strake of side plating of steel short deckhouses and the ends of steel long deckhouses fitted on the strength deck, grade of steel and yield stress shall be the same as required for the strength deck in this region. The width of the bottom strake shall not be less than $0,5h$.

2.12.2.3 Whenever practicable, the end bulkheads of superstructures and deckhouses shall be situated in line with the hull transverse bulkheads or as close to the latter as possible.

Web frames or vertical webs, bulkheads or partial bulkheads shall be fitted in superstructures and deckhouses in such a way as to be in line with girder webs or bulkheads of hull structures located below. The vertical webs of end bulkheads shall be fitted in line with the vertical webs of hull bulkheads.

2.12.2.4 The lower ends of vertical stiffeners of the end bulkheads of the 1st tier superstructures and deckhouses shall be welded to the deck. The lower ends of side vertical stiffeners of 1st tier houses shall be attached to the deck by brackets.

2.12.2.5 Adequate strengthening shall be provided for the structures of deckhouses and superstructures where launching and recovery appliances for survival craft and rescue boats are fitted.

2.12.3 Design loads.

2.12.3.1

1. design pressure on the superstructure sides is determined according to 2.2.3;

2. design pressure on weather areas of the superstructure and deckhouse decks shall be determined by the formula

$$p = \alpha \cdot p_w, \quad (2.12.3.1.2)$$

where: p_w – wave load at the deck level according to 1.3.2.2;

$\alpha = 0,9$ for forecastle deck, long forecastle deck or part of long bridge deck within $0,2L$ from the fore perpendicular;

$\alpha = 0,8$ for poop deck, long poop deck or part of long bridge deck within $0,2L$ from the after perpendicular;

$\alpha = 0,7$ for short bridge and deckhouse decks, long superstructure and deckhouse decks, long forecastle and poop decks within the midship region.

For areas of long bridge and deckhouse decks, long forecastle and poop decks outside the midship region and outside areas situated at $0,2L$ from the fore or after perpendicular, α shall be determined by linear interpolation.

but not less than p_{\min} .

For the 1st tier superstructure and deckhouse decks, p_{\min} in kPa, shall be determined by the following formulae:

for forecastle, long forecastle decks or part of long bridge deck within $0,2L$ from the fore perpendicular

$$p_{\min} = 0,1L + 7;$$

for poop, long poop deck or part of long bridge deck within $0,2L$ from the after perpendicular

$$p_{\min} = 0,015L + 4 \quad \text{for } L \leq 80 \text{ m};$$

$$p_{\min} = 0,03L + 2,8 \quad \text{for } L > 80 \text{ m};$$

for bridge and deckhouse decks, long forecastle and poop decks within the midship region

$$p_{\min} = 0,015L + 4;$$

for areas of bridge and deckhouse decks, long forecastle and poop decks outside the midship region and outside areas situated at $0,2L$ from the fore or after perpendicular, p_{\min} shall be determined by linear interpolation.

For decks of the superstructures and deckhouses of the 2nd and upper tiers

$$p_{\min} = 2 \text{ kPa.}$$

For ships greater than 250 m in length, p_{\min} is determined taking $L = 250$ m.

For ships of restricted area of navigation, p_{\min} may be reduced by multiplying by the factor φ_r , obtained from Table 1.3.1.5.

2.12.3.2 Pressure on the end bulkheads of superstructures and deckhouses as well as on sides of deckhouses p , in kPa, is determined by the formula

$$p = 5,1nc_2(kz_0 - z_1), \quad (2.12.3.2)$$

where: n – factor determined from Table 2.12.3.2-1;

$$c_2 = 0,3 + 0,7b/B_x, \quad \text{in this case } c_2 \geq 0,5;$$

$$k = 1,0 + \left(\frac{x_1/L - 0,45}{C_b + 0,2} \right)^2 \quad \text{when } x_1/L \leq 0,45;$$

$$k = 1,0 + 1,5 \left(\frac{x_1/L - 0,45}{C_b + 0,2} \right)^2 \quad \text{when } x_1/L > 0,45;$$

for the sides of deckhouses the factor k is assumed to vary for the length of bulkhead. For this purpose the deckhouse is subdivided into parts of approximately equal length not exceeding $0,15L$ each, and x_1 is taken as the distance between the after perpendicular and the middle of the part considered;

C_b – shall be taken as not less than 0,6, nor greater than 0,8; for the aft end bulkheads forward of amidships $C_b = 0,8$;

z_0 – as given in Table 2.12.3.2-2;

z_1 – vertical distance, in m, from the summer load waterline to the mid-point of the plate panel considered or the mid-point of span of the bulkhead stiffener.

The above-stated value of factor n apply to a ship having the freeboard equal to minimum tabular freeboard of Type "B" ships, and a standard height of superstructures according to Section 4 of the Load Line Rules for Sea-Going Ships.

If the deck of the tier considered is situated higher than the standard position due to an increase of freeboard, as against the tabular value, then the appropriate factor n may be determined by linear interpolation

between the values of that factor for superstructures with standard and actual positions of decks under the superstructures.

In any case, the design pressure shall not be taken less than indicated in Table 2.12.3.2-3.

Table 2.12.3.2-1

Bulkhead	Structure		n
Front	Unprotected	1st tier	$2 + L_0/120$
		2nd tier	$1 + L_0/120$
		3rd tier	$0,5 + L_0/150^1$
Protected			
Aft end	Aft of amidships		$0,7 + (L_0/1000) - 0,8x_1/L_0$
	Forward of amidships		$0,5 + (L_0/1000) - 0,4x_1/L_0$
L_0 – length of ship, in m (to be taken not greater than 300 m for the purpose of calculation); x_1 – distance, in m, between the after perpendicular and the bulkhead under consideration. ¹ Formula is also used for the deckhouses sides.			

Table 2.12.3.2-2

L , m	z_0 , m	L , m	z_0 , m
20	0,87	180	9,85
40	2,59	200	10,25
60	4,07	220	10,55
80	5,42	240	10,77
100	6,60	260	10,92
120	7,69	280	11,00
140	8,63	300	11,03
160	9,35	350	11,05

Table 2.12.3.2-3

L , m	Design pressure p , in kPa	
	for 1st tier unprotected fronts	elsewhere
≤ 50	15,6	7,8
$50 < L < 250$	$13 + 0,052L$	$6,5 + 0,026L$
≥ 250	26	13

For ships of restricted area of navigation the design pressure may be reduced by multiplying by the factor φ_r , obtained from Table 1.3.1.5.

2.12.4 Розміри конструкцій надбудов, рубок і кварталдеку.

2.12.4.1 The thickness of side plating of short and long bridges, forecastle and poop, long forecastle and poop shall be determined according to **2.2.4.1** using the design loads given in **2.12.3.1.1**.

For short bridges, forecastle and poop, $k_\sigma = 0,7$.

For long bridge, long forecastle and poop outside the end portions, k_σ is determined according to **2.2.4.1**; at sections in way of end bulkheads $k_\sigma = 0,7$;

within the end portions k_σ shall be determined by linear interpolation.

The thickness of side plating of long bridges, long forecastle and poop shall satisfy the requirements of **2.2.4.8**.

In any case, the thickness s_{min} , in mm, of side plating of short bridges, forecastle and poop shall not be less than:

for superstructures of the lowest tier

$$s_{min} = (4,5 + 0,025L) \cdot \sqrt{\eta}; \quad (2.12.4.1-1)$$

for superstructures of other tiers

$$s_{min} = (4 + 0,02L) \cdot \sqrt{\eta}, \quad (2.12.4.1-2)$$

where η is obtained from Table 1.1.4.3.

Where $L > 300$ mm, L shall be taken equal to 300 m.

For ships of unrestricted service **A** and ships of restricted area of navigation **R1**, **A-R1** the reduction of minimal thickness, but not more than 10 %, is permitted in proportion to the ratio of adopted spacing to standard spacing, where the adopted spacing is less than the standard one (refer to **1.1.3**). In any case, for ships of 30 m and greater in length the minimum thickness shall be not less than 5 mm.

2.12.4.2 The thickness of deck plating of short and long bridges, forecastle and poop, long forecastle and poop, short and long deckhouses shall be determined according to **2.6.4.1.1** and **2.6.4.1.2** using the design loads stated in **2.12.3.1.2**.

For short bridges, forecastle, poop and short deckhouses, $k_{\sigma} = 0,7$.

For long bridge, long forecastle and poop outside the end portions, k_{σ} is determined as for the strength deck according to 2.6.4.1.2;

at sections in way of end bulkheads k_{σ} shall be determined by linear interpolation.

The thickness of deck plating of long bridges, long forecastle and poop, long deckhouses shall satisfy the requirements of 2.6.4.1.5 for the upper deck between the side and the line of large openings.

In any case, the thickness s_{\min} , in mm, of deck plating of short bridges, forecastle and poop, short deckhouses shall not be less than:

for open forecastle deck

$$s_{\min} = (4 + 0,04L) \cdot \sqrt{\eta} \quad \text{for } L < 100 \text{ m}; \quad (2.12.4.2-1)$$

$$s_{\min} = (7 + 0,01L) \cdot \sqrt{\eta} \quad \text{for } L \geq 100 \text{ m};$$

for other decks of superstructures and deckhouses of the lowest tier

$$s_{\min} = (5 + 0,01L) \cdot \sqrt{\eta}; \quad (2.12.4.2-2)$$

for superstructure and deckhouse decks of other tiers

$$s_{\min} = (4 + 0,01L) \cdot \sqrt{\eta}, \quad (2.12.4.2-3)$$

where: η is obtained from **1.1.4.3**.

Where $L > 300$ mm, L shall be taken equal to 300 m.

For ships of unrestricted service **A** and ships of restricted area of navigation **R1**, **A-R1**, the reduction of minimal thickness, but not more than 10 %, is permitted in proportion to the ratio of adopted spacing to standard spacing, where the adopted spacing is less than the standard one (refer to **1.1.3**).

In any case, the minimum thickness shall not be less than 5 mm for ships of length $L \geq 50$ m.

The minimum thickness may be reduced to 4 mm for ships of length $L \leq 50$ m, and to 3 mm for ships of length $L < 20$ m.

2.12.4.3 The plate thickness of the end bulkheads of superstructures, sides and end bulkheads of deckhouses shall not be less than that determined by Formula (1.6.4.4) taking:

$$m = 15,8;$$

$$k_{\sigma} = 0,6;$$

$$\Delta s = 0;$$

$$p - \text{as defined in } \mathbf{2.12.3.2}.$$

The thickness of side plating of deckhouses may be not less than that of superstructures as stated in **2.12.4.1**, provided they are arranged similarly over the ship's length and depth.

The thickness of bottom plates of end bulkheads in superstructures (deckhouses) of 1st tier shall be increased by 1 mm as compared with the design thickness.

The width of bottom plate shall be not less than 0,5 mm. If the deckhouse front extends in a fair convex form beyond the intersection with the deckhouse sides, the thickness of plating may be taken 0,5 mm less as compared with the design value.

2.12.4.4 In any case, the plate thickness s_{\min} , in mm, of superstructure end bulkheads, sides and end bulkheads of deckhouses shall not be less than:

for the lowest tier

$$s_{\min} = (5 + 0,01L) \cdot \sqrt{\eta}, \quad (2.12.4.4-1)$$

for other tiers

$$s_{\min} = (4 + 0,01L) \cdot \sqrt{\eta}, \quad (2.12.4.4-2)$$

where: η is obtained from **1.1.4.3**.

Where $L > 300$ mm, L shall be taken equal to 300 m.

In any case, the minimum thickness shall not be less than 5 mm for ships of length $L \geq 50$ m.

The minimum thickness may be reduced to 4 mm for ships of length $L \leq 50$ m, and to 3 mm for ships of length $L < 20$ m.

Reduction of the minimum thickness is not permitted for fronts of bridge and unprotected front of poop in ships of length $L \geq 20$ m.

2.12.4.5 Framing of the sides, decks and end bulkheads of the forecastle, poop and bridge, quarter deck and deckhouse shall satisfy the following requirements:

.1 side framing of the superstructure shall comply with the requirements for side framing in 'tween deck space as specified in **2.5.4.2 - 2.5.4.5** using the design loads given in **2.12.3.1.1**. For longitudinals and side stringers of short bridge, forecastle and poop, $k_{\sigma} = 0,65$.

For longitudinals and side stringers of long bridge, long forecastle and poop outside the end portions, k_{σ} is determined according to **2.5.4.3** and **2.5.4.4**;

at sections in way of the end bulkheads $k_{\sigma} = 0,65$; within the end portions k_{σ} shall be determined by linear interpolation;

.2 underdeck framing of the superstructure and deckhouse shall satisfy the requirements of **2.6.4.2 - 2.6.4.9** using the design loads stated in **2.12.3.1.2**.

For longitudinals and deck girders of long bridge, long forecastle and poop outside the end portions, k_{σ} is determined in accordance with **2.6.4.2** and **2.6.4.4**; at sections in way of the end bulkheads $k_{\sigma} = 0,65$; within the end portions k_{σ} shall be determined by linear interpolation;

.3 section modulus of vertical stiffeners of the end bulkheads of superstructures, deckhouse sides and end bulkheads shall not be less than that determined according to **1.6.4.1** taking:

$$k_{\sigma} = 0,6;$$

$$\Delta W = 0;$$

$$\omega_k = 1;$$

p – as defined in **2.12.3.2**;

$m = 12$, if the lower end of the stiffener is attached to the deck by a bracket;

$m = 10$, if the lower end of the stiffener is welded to the deck;

$m = 8$, if the lower end of the stiffener is sniped.

The section modulus of stiffeners of deckhouse sides need not be greater than that of frames of superstructures as stated in **2.12.4.5.1**, where arranged similarly over ship's length and depth.

2.12.4.6 The scantlings of members of bulkheads and partial bulkheads inside the superstructures and deckhouses shall satisfy the requirements of **2.7.4.5**, unless stated otherwise.

2.12.5 Special requirements.

2.12.5.1 The upper deck areas situated under the long bridge, long forecastle and poop outside the end portions shall satisfy the requirements of **2.6** for the second deck.

Requirements for the upper deck areas situated under the ends of long bridge, long forecastle and poop are determined by linear interpolation between the requirements for the upper deck and those for the second deck.

2.12.5.2 In way of the end bulkheads the following requirements shall be complied with:

.1 where the superstructure end bulkhead is not in line with the transverse bulkhead of the hull, partial bulkheads or pillars shall be fitted in spaces below the end bulkhead, or frames and beam knees shall be strengthened;

.2 where the end bulkhead of long deckhouse is not in line with the transverse bulkhead below, short deck girders shall be fitted in line with deckhouse sides under the house deck so as to extend further for three frame spaces forward and aft of the deckhouse end bulkhead;

.3 at the section, where the end bulkheads of superstructures and deckhouses abut on the undeck longitudinal structures and the sides of deckhouses _ on the transverse underdeck structures fitted below (bulkheads, partial bulkheads, undeck girders, deck transverses, etc.), the webs of these underdeck structures shall be stiffened with brackets.

2.12.5.3 The structure at the ends of superstructures shall satisfy the following requirements:

.1 at the ends of bridge, long forecastle and poop located within 0,6L midship region of a ship with a length $L \geq 60$ m the side plating shall be extended beyond the end bulkhead with smooth tapering to the ship's side on a length d_1 , in m, (refer to Fig. 2.12.5.3.1), determined by the formula:

$$d_1 \geq 0,2 \cdot (0,5 \cdot B_2 + h), \quad (2.12.5.3.1)$$

where: for B_2 , h – refer to 2.12.1.3.

The value of d_1 may be reduced provided that the thickness of bottom strake of the superstructure side plating, sheerstrake and deck stringer plate within the region shown in Fig. 2.12.5.3.1 is increased;

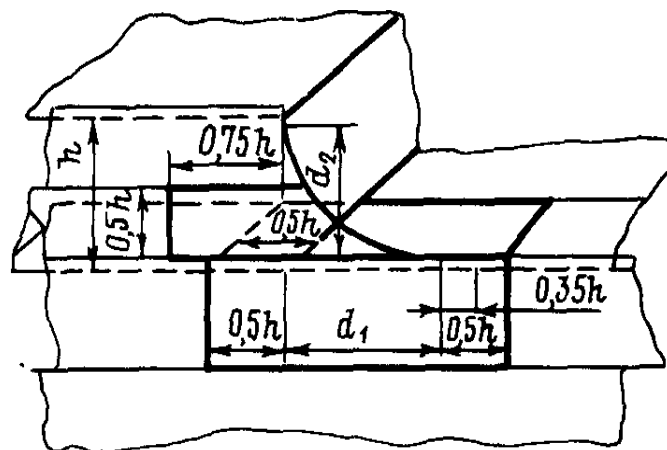

$$0,5h \leq d_2 = 0,65d_1 \leq 0,75h$$

Fig. 2.12.5.3.1

.2 if the end of superstructure (forecastle, poop) is located within 0,1L from the fore or after perpendicular, as well as in ships of length $L \geq 65$ m the value of d_1 may be reduced by half.

If the end of a superstructure is located outside the above-mentioned regions and outside 0,6L amidships, the value of d_1 shall be determined by linear interpolation;

.3 the blunted ends of projecting side plates shall be machined flush with the deck. The curved edge of side plating shall be stiffened by flat bar carried down for 50 mm from the edge. The ends of that bar shall be sniped.

Openings in side plating projecting beyond the ends of a superstructure are normally not permitted.

The projecting plates shall be attached to the bulwark by means of flexible joints;

.4 at the ends of short bridge not extending from side to side of ship the attachment of the side to the deck shall be made similarly to the attachment required by 2.12.5.4 for deckhouses, otherwise gussets shall be used to provide smooth transition from the side to a short deck girder strengthening the deck under that side with simultaneous strengthening of the deck stringer plate within the region shown in Fig. 2.12.5.3.1.

2.12.5.4 Attachment of sides of the deckhouse to the end bulkhead arranged within 0,6L amidships of a ship with a length $L \geq 65$ m shall be performed by rounding with a radius r , in m, determined by the formula:

$$r = l_1 \cdot (1,5 + 0,1 \cdot l_1/b)/100 \leq 1,4, \quad (2.12.5.4)$$

where: b – breadth of the deckhouse in way of the end bulkhead, in m;
 l_1 – refer to 2.12.1.3.

2.12.5.5 Rectangular openings in outer sides and top plating of long deckhouses shall have their corners well rounded and shall be substantially framed.

Door openings in the sides of a deckhouse, arranged within 0,6L amidships, shall be additionally reinforced with thickened plates as shown in Fig. 2.12.5.5. Rectangular openings are not permitted for a length not less than the height of the deckhouse counted from the end bulkhead, if the deckhouse is situated on the strength deck.

If door openings in sides are arranged outside the midship region or if the deckhouse is short, the thickened plates may be fitted only below the opening as shown in Fig. 2.12.5.5.

Where the distance between the expansion or sliding joints is less than a triple height of the deckhouse, it is sufficient to provide the rounding of the corners of openings. Openings for side scuttles shall have the upper and lower edges reinforced with horizontal stiffeners.

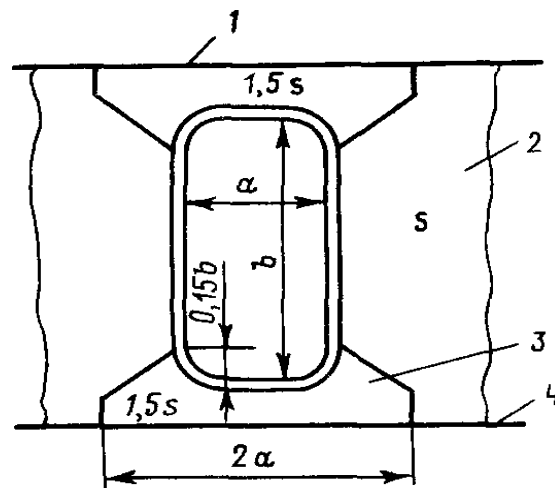

1 – deckhouse top; 2 – deckhouse side; 3 – thickened plate; 4 – strength dec

Fig. 2.12.5.5

2.12.5.6 The structures in way of the break at connection of the upper deck to quarter deck in ships of 90 m and under shall satisfy the following requirements:

.1 the upper deck plating in way of the break shall extend abaft the break for three frame spaces in ships of 60 m in length and above, and for two frame spaces in ships less than 60 m in length.

The upper deck plating of ships less than 40 m in length need not extend abaft the break.

.2 the upper deck stringer plate shall extend abaft the steel plating for three frame spaces, where $L \geq 60$ m, and for two frame spaces, where $L < 60$ m. The stringer plate so arranged shall be tapered from its full width to a width equal to the depth of frame to which it is welded;

.3 the stringer plate of quarter deck shall extend forward in the form of a bracket gradually tapered to ship's side on a length of three frame spaces. The quarter deck stringer plate projecting beyond the break shall be adequately stiffened and its free edge shall have a face plate or flange;

.4 the sheerstrake of quarter deck shall extend forward of the deck stringer plate projecting beyond the break bulkhead for at least 1,5 times the height of break and shall be smoothly tapered into the upper edge of ship's side sheerstrake. For other structural requirements, refer to 2.12.5.3;

.5 diaphragm plates spaced not more than 1,5 m apart shall be fitted over the ship's breadth between the overlapping decks in way of the break. The thickness of diaphragms shall not be less than the thickness of the break bulkhead plating.

The diaphragm plates shall be strengthened by vertical stiffeners.

Vertical stiffeners with effective flange shall have a moment of inertia not less than that determined by Formula (1.6.5.6-1).

Continuous welds shall be used to attach the horizontal edges of diaphragm plates to the decks, and the vertical edges to break bulkhead on one side, and on the other side to an extra supporting bulkhead made of continuous plate welded to the decks over the ship breadth. The plate thickness of that bulkhead shall be not less than the thickness of break bulkhead plating and may have openings between diaphragms;

.6 where a supporting bulkhead is fitted, the diaphragm plates shall be stiffened with brackets fitted to their ends (refer to Fig. 2.12.5.6.6);

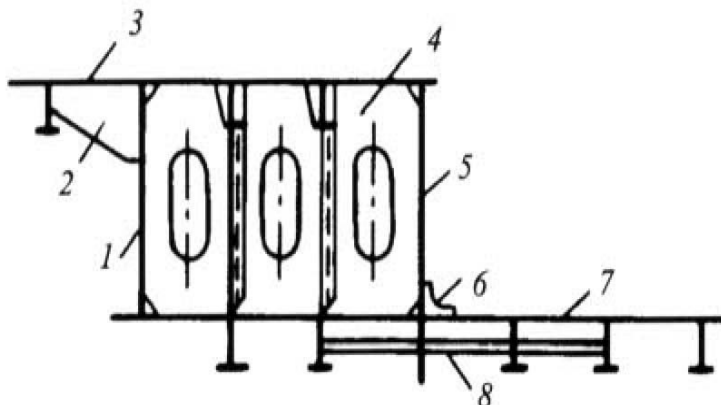

1 - supporting bulkhead; 2, 6 - brackets; 3 - quarter deck; 4 - diaphragm; 5 - break bulkhead; 7 - upper deck;
8 - stiffener in line with bracket

Fig. 2.12.5.6.6

.7 where a raised quarter deck is adjoining the bridge, it shall extend into that superstructure for two frame spaces beyond the break, the extension being, in any case, not less than the elevation of superstructure above the quarter deck.

The quarter deck stringer plate shall extend forward for two frame spaces with the width gradually reduced as required by 2.12.5.6.2.

Strengthening of the overlapping decks in way of break shall comply with requirements of 2.12.5.6.5 and 2.12.5.6.6 depending on the location of the break along the length of the ship.

The superstructure side plates extending aft of the superstructure shall be smoothly tapered into the sheerstrake on a length of at least 1,5 times the height of break (refer also to 2.12.5.3.1).

.8 strengthening in case where the break bulkhead is located within 0,25L from the after perpendicular shall comply with the following requirements:

in ships greater than 60 m in length, the supporting bulkhead fitted over the breadth the ship may be omitted. The free edges of diaphragm plates shall, in this case, be stiffened with face plates or flanges of a width equal to at least ten thicknesses of the diaphragm plate;

in ships of 60 m in length and below, the upper deck plating need not extend aft of the break over the ship breadth, however, the upper deck stringer and the raised quarter deck stringer and sheerstrake shall be extended forward and aft as provided in 2.12.5.6.3 and 2.12.5.6.4.

2.12.5.7 The use of aluminium alloys for the construction of deckhouses is permitted. Decks of accommodation and service spaces situated above the machinery and cargo spaces shall be made of steel.

The scantlings of aluminium deckhouses shall be determined according to 1.6.6. The minimum scantlings shall be the same as those required for steel deckhouses.

The degree to which the deckhouse of aluminium alloys contributes to longitudinal bending of the hull and stresses in ship's hull and deckhouse shall be determined according to the procedure approved by the Register.

2.12.6 Helicopter deck.

2.12.6.1 The design of the Helicopter Deck, which is the upper deck or the superstructure or deckhouse top:

.1 The main members of the deck framing should be installed parallel to the axis of the helicopter during its take-off and landing;

.2 Plating thickness, section modulus cross-section area of the deck main and web members webs is determined in accordance with 3.2.4.1 ÷ 3.2.4.3 with Q , determined by the Formula (3.2.3.4), and l_a and l_b taken 0,3 m. In formula (3.2.3.4) Q_0 is taken equal to the take-off weight of the helicopter, in kN; $k_d = 3$, $n_0 =$

2, $n = 1$;

.3 Scantling of members, pillars, as well as cross stays and panting beams for the helicopter, which is fitted with skids instead of wheels, shall be determined by direct calculation.

2.12.6.2 The design of the Helicopter Deck (platform), which is not the upper deck or the superstructure or deckhouse top:

.1 Plating thickness, section modulus cross-section area of the deck main and web members webs is determined in accordance with **2.12.4.2**, **2.12.4.5**, **2.12.6.1**, as for the short deck house or deck house of corresponding tier;

.2 Scantling of stiffeners and panting beams is determined in accordance with **2.9** as for pillars;

.3 Scantling of members, pillars, as well as cross stays and panting beams, are to be determined taking into account forces of inertia of the mass of deck structures. Acceleration to determine the inertial forces are determined according to **1.3.3.1** and **1.3.4.4**;

.4 Use of aluminum alloys is allowed. Strength and stability of the Helicopter decks made of aluminum alloys are allowed to be determined by the method of model tests, which is to be carried out in the presence of a representative of the Register under an agreed program;

.5 Helicopter Deck (platform) construction is to take into account the provisions of **11.2.6** of Part III "Equipment, Arrangements and Outfit".

2.13 MACHINERY CASINGS

2.13.1 General.

Openings in decks and platforms over engine rooms shall be protected by strong casings.

The casings may be omitted only in cases where the space on the deck or platform is a part of the engine room.

2.13.2 Construction.

2.13.2.1 Where there are large openings in the deck in way of engine room, additional pillars and deck transverses shall be fitted for strengthening of the deck in way of machinery casing.

2.13.2.2 For the lower strake of the casing longitudinal wall plating, adjoining the strength deck within the $0,6L$, midship region of ships with a length $L \geq 65$ m of steel grade and yield stress shall be the same as for the strength deck plating in this region.

2.13.2.3 Where the opening for machinery casing is arranged in the strength deck, the requirements of **2.6.5.1** regarding the design of corners and compensation for openings shall be complied with.

2.13.3 Scantlings of machinery casing structures.

2.13.3.1 The part of machinery casing located inside the enclosed spaces (tween deck spaces, forecastle, poop, bridge, deckhouse) shall comply with the requirements of **2.7.4.5** for partial bulkheads.

The spacing of stiffeners shall not exceed 0,9 m.

The thickness of plating of the part of machinery casing located inside the poop, bridge or deckhouse may be 0,5 mm less than specified.

2.13.3.2 The part of machinery casing located below the bulkhead deck shall comply with the requirements of **2.7.2.3**, **2.7.4.1** - **2.7.4.3** for watertight bulkheads where it is included in subdivision calculation as watertight construction.

2.13.3.3 The part of machinery casing located above weather deck shall comply with the requirements of **2.12** for deckhouses situated in the same region of the ship. In calculating the design loads by Formula (2.12.3.2) $c_2 = 1$.

2.14 BULWARKS

2.14.1 General.

Bulwarks of strong construction shall be provided in places specified in **8.6**, Part III "Equipment, Arrangements and Outfit".

The construction of bulwarks in the midship region of ships of 65 m and above shall be such that the bulwark does not contribute to longitudinal bending of the hull.

2.14.2 Construction.

2.14.2.1 The height of the bulwark as measured from the upper edge of the deck plating or from that of planking, if any, to the upper edge of the rail section shall comply with the requirements of **8.6.2**, Part III "Equipment, Arrangements and Outfit".

2.14.2.2 The bulwark plating within the 0,6L midship region of ships of 65 m and above shall not be welded to the upper edge of sheerstrake. Outside the above-mentioned region as well as in ships less than 65 m in length, the openings cut in bulwarks shall be so designed as to ensure a smooth transition (with a radius not less than 100 mm) from the bulwark plate to the sheerstrake.

Within 0,07L from the fore perpendicular the welding of bulwark plating to the sheerstrake is necessary.

2.14.2.3 The bulwark shall be supported by stays spaced not more than 1,8 m apart. In the region of uprights for timber deck cargo, fastening to bulwarks, as well as at the fore end within 0,07L from the fore perpendicular, the spacing of stays shall be not more than 1,2 m.

In the ships with large flare of sides and in ships with minimum assigned freeboard, stays may be required to be fitted at every frame within the region considered.

2.14.2.4 The stays shall be fitted in line with deck beams, brackets and other structures and shall be welded to the rail section, bulwark plate and deck. The attachment of stays to bulwark shall be ensured on a length not less than half the height of the bulwark.

In welding the stays to the deck, holes sufficient in size to allow free passage of water to the scuppers shall be provided in the stays.

The welded connection of the beam (bracket) to deck plating under the stay shall not be weaker than the attachment of stay to deck.

Directly under the lower ends of stays no cut-outs in the deck beams and no gaps between frame ends and deck are permitted.

The dimensions of lightening holes in stays shall not exceed half the stay width in any section of the stay. The free edges of stays shall be stiffened with face plates or flanges. In general, the flanges (face plates) of stays shall not be welded to deck plating and rail section.

The flanges (face plates) on the outer edge of the stay shall not be welded to horizontal stiffener (flange) of lower edge of the bulwark in way of continuous cut-out.

2.14.2.5 The rail section shall have a flange (face plate) or shall be of bulb profile.

The lower edge of bulwark shall be stiffened with horizontal stiffener or flange in way of continuous cut-out.

Bulwarks shall be adequately strengthened in way of mooring pipes, fairleads and eyeplates for cargo gear.

2.14.2.6 Requirements for the design of freeing ports in bulwarks are given in **1.1.6.7**.

2.14.3 Loads on bulwarks.

The external pressure determined by the Formula (1.3.2.2-2) is the design pressure p , in kPa, acting on the bulwark. The design pressure shall be taken not less than

$$p_{\min} = 0,02L + 14, \quad (2.14.3)$$

but not less than 15 kPa.

Where $L > 300$ m L shall be taken equal to 300 m.

For ships of restricted area of navigation the value of p_{\min} may be reduced by multiplying by the factor φ_r , obtained from Table 1.3.1.5.

2.14.4 Scantlings of bulwark structures.

2.14.4.1 The thickness of the bulwark plating shall not be less than:

$$s = 0,065L + 1,75, \text{ for } L \leq 60 \text{ m and} \quad (2.14.4.1)$$

$$s = 0,025L + 4,0, \text{ for } L > 60 \text{ m,}$$

but not less than 3,0, nor greater than 8,5 mm.

The thickness of bulwark plating of a superstructure located beyond 1/4 of the ship's length from the fore perpendicular, as well as that of bulwark plating of 2nd tier deckhouses or superstructures may be reduced by 1 mm.

For 3rd and above tiers of the deckhouses the thickness of the bulwark plating need not exceed the thickness required for the plating of sides of 3rd tier deckhouse.

2.14.4.2 The section modulus of bulwark stay adjoining the deck plating shall not be less than determined according to **1.6.4.1** takin:

p – as defined in **2.14.3**;

$m = 2$;

$$k_{\sigma} = 0,65.$$

Where the bulwarks are cut to form a gangway or provision is made for expansion joints, the section modulus of stay at the ends of the openings or expansion joints shall be increased by 25 %.

The width of stay at the upper end shall be equal to that of the rail section.

2.14.4.3 Where the deck cargo effect on the bulwark is contemplated, the scantlings of the bulwark stays shall be determined by strength calculation involving effect of the said cargo, with regard for heel of the ship determined by Formula (1.3.3.1-5) and acceleration in the horizontal-transverse direction, determined by Formulae (1.3.3.1-2); the permissible stress factor is determined according to **2.14.4.2**.

3. REQUIREMENTS FOR STRUCTURES OF SHIPS OF SPECIAL DESIGN

3.1 SHIPS WITH LARGE DECK OPENINGS

3.1.1 General and symbols.

3.1.1.1 The requirements of this Chapter are additional to those of Sections 1 and 2.

The functional requirements on load cases to be considered on finite element analysis for the structural strength assessment of container ships and ships, dedicated primarily to carry their cargo in containers, both of length 150 m or above are specified in IACS UR S34 (May 2015).

3.1.1.2 The requirements for deck structure, exclusive of those for cantilever beams, apply to ships with single, twin and triple cargo hatchways which are considered to form a large deck opening meeting the following conditions:

$$b/B \geq 0,7; \quad l/l_m \geq 0,7.$$

The requirements of this Chapter shall be applicable throughout the entire cargo hatch region, including the engine room, provided it is located between the cargo holds.

3.1.1.3 The requirements for container securing arrangements and hull structures, which take up forces exerted by the said arrangements, apply to container ships.

3.1.1.4 The cantilever beam is a short deep half beam for which the supporting effect of the side hatch coaming is disregarded in the strength and buckling strength calculation to be made for deck grillage in accordance with **2.6.4.4** and **2.6.4.9** respectively.

3.1.1.5 For the purpose of this Chapter the following symbols have been adopted:

b – breadth of deck opening determined as the distance between the outer longitudinal edges of hatchway openings at ship's sides, in m;

l – length of hatchway opening, in m;

l_m – distance between centres of transverse deck strips at each end of opening, in m.

c – distance between transverse edges of adjoining openings, in m;

n – total number of 20-foot containers carried by the ship.

3.1.2 Construction.

3.1.2.1 For ships with a length $L \geq 80$ m longitudinal framing system is provided for the deck and bottom.

3.1.2.2 Upper deck and side longitudinals shall be continuous within the region stated in **3.1.1.2**.

3.1.2.3 Ends of cargo hatch continuous side coamings shall be attached as required by **1.7** and **2.6.2**. It is not recommended that continuous side coamings be attached to the front bulkhead of the aft superstructure and the aft bulkhead of the forecastle.

3.1.2.4 Abrupt changes of cross section and shape of members referred to in **3.1.2.2** over the length of the ship is generally not permitted. Where such changes are necessary, arrangements shall be such as to minimize the creation of stress concentration and attention shall be paid to provision of buckling strength.

3.1.2.5 It is recommended that transverse and longitudinal deck strips have a box-shaped cross-section.

3.1.2.6 Openings in the deck plating in immediate proximity to the attachments of transverse and longitudinal deck strips are not permitted.

3.1.2.7 Large deck openings:

.1 adjacent corners of hatch openings in the upper deck arranged in one line shall be rounded with a radius *r*, in m, (refer to Fig. 3.1.2.7.1) not less than

$$r = kb, \tag{3.1.2.7.1}$$

where: $k = 0,025$ when $c/b \leq 0,04$;

$k = 0,050$ when $c/b \geq 0,2$; the intermediate values of k shall be obtained by linear interpolation;

for c and b – refer to 3.1.1.5.

In way of longitudinal deck strips the value of r may be reduced by 40 %.

Given below are minimum radii of rounding of opening corners:

$r_{\min} = 300$ mm in way of deck stringer plate;

$r_{\min} = 250$ mm in way of longitudinal deck strips.

Thickened insert plates are required at hatch corners (refer to Fig. 3.1.2.7.1);

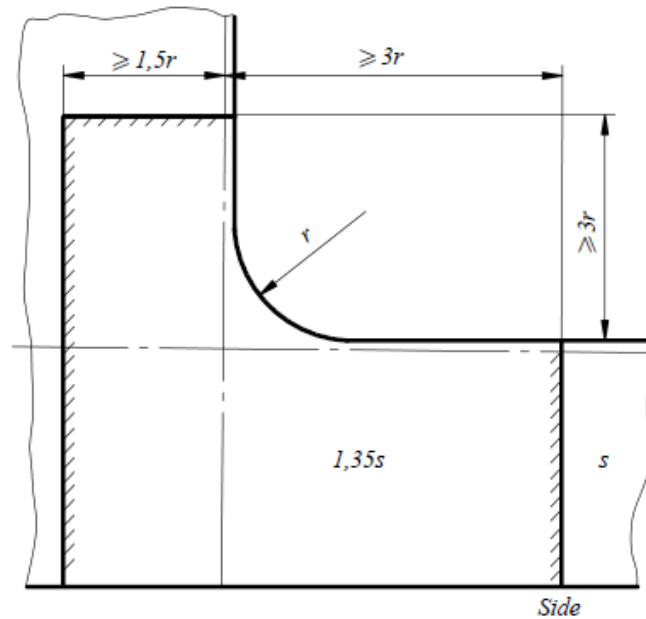

Fig. 3.1.2.7.1

.2 in way of conjugations of open and enclosed parts of the hull (adjacent to the engine room, bow, etc.) the corner radius of hatch openings shall not be less than

$$r = 0,07b;$$

(3.1.2.7.2)

.3 for general requirements regarding deck openings, refer to 2.6.5.1.

3.1.2.8 The cantilever beams shall be fitted in line with web frames. Their connection shall satisfy the requirements of 1.7.2.3.

The cantilever beams shall be fitted with minimum stiffeners as shown in Fig. 3.1.2.8.

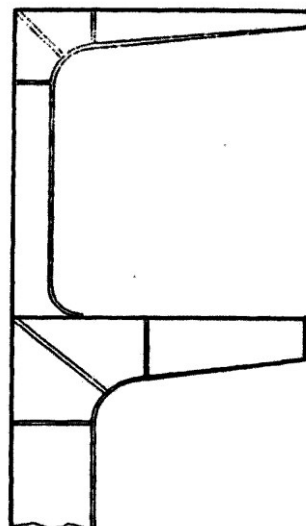

Fig. 3.1.2.8 Stiffening of cantilever beams

3.1.2.9 Stiffeners, brackets or deep members shall be fitted under the vertical guides or corner fittings of containers in double bottom of container ships. The inner bottom plating in these locations shall be increased in thickness or the corner fitting sockets shall be welded therein.

The above also applies to lashing pots.

Similar increase in the plating thickness and stiffening in way of container corner fitting pockets and lashing pots shall be provided in deck structure.

3.1.3 Design loads.

3.1.3.1 The design still water bending moment shall be determined in accordance with **1.4.3**.

3.1.3.2 The vertical wave bending moment shall be determined in accordance with **1.4.4**.

3.1.3.3 The design horizontal wave bending moment M_h , in kN/m, is determined by the formula

$$M_h = 250 k_h c_w B L^2 C_b \alpha_h \cdot 10^{-3}, \quad (3.1.3.3)$$

where: $k_h = \alpha (d/b+0,3)$;

$\alpha = 1 - 4d/L$;

for c_w – refer to **1.3.1.4**;

$\alpha_h = 0,5 [1 - \cos(2\pi x/L)]$;

x – distance between the considered section and the after perpendicular, in m.

3.1.3.4 The design components of a wave torque, in kN/m, are determined by the formulae:

$$M_{tw_1} = 63k_1 c_w B L^2 \alpha_{t_1} \cdot 10^{-3}; \quad (3.1.3.4-1)$$

$$M_{tw_2} = 63k_2 c_w B L^2 C_b \alpha_{t_2} \cdot 10^{-3}; \quad (3.1.3.4-2)$$

$$M_{tw_3} = 126k_2 c_w B L^2 C_b \alpha_{t_3} \cdot 10^{-3}. \quad (3.1.3.4-3)$$

where: $k_1 = 2 \alpha \chi_o [1 + 3,6 (C_{WL} - 0,7)] B/L$;

$k_2 = 10 \alpha_1 d e/(LB)$;

$\alpha_1 = 1 - 8 d/L$;

$\chi_o = 1 - 4 C_{WL} B/L$;

C_{WL} – water plane area coefficient for summer load waterline;

For α – refer to **3.1.3.3**;

e – vertical distance from the torque centre to a point at $0,6d$ above the base line; the torque centre position shall be determined in accordance with the procedure approved by the Register;

$$\alpha_{t_1} = 0,5 \left(1 - \cos \frac{2\pi x}{L} \right);$$

$$\alpha_{t_2} = \sin \frac{3\pi x}{L};$$

$$\alpha_{t_3} = \sin \frac{2\pi x}{L};$$

for x – refer to **3.1.3.3**.

3.1.3.5 For container ships, the design statical torque M_{ts} , in kN/m, is determined by the formula

$$M_{ts} = 30\sqrt{nB}, \quad (3.1.3.5)$$

where: n – total number of 20-ft containers carried by ship.

3.1.3.6 For ships of restricted area of navigation, the horizontal wave bending moment (refer to **3.1.3.3**) and the components of a wave torque (refer to **3.1.3.4**) shall be multiplied by the reduction factor φ_r , determined in accordance with **1.4.4.3**.

3.1.3.7 The design loads for cantilever beams are determined in accordance with **2.6.3**.

3.1.3.8 The design loads on container securing arrangements are determined with due regard for the inertia forces caused by ship's accelerations at motions in accordance with **1.3.3.1**. The design mass value of ISO series **1** containers is:

24,0 t for 20-ft containers;

30,5 t for 40-ft container.

When calculating strength of container securing arrangements fitted on weather deck, account shall be taken of loads from the wind in the direction perpendicular to the centreline of the ship.

The design value of wind pressure is $p = 1,0 \text{ kPa}$.

3.1.4 Scantlings of structural members.

3.1.4.1 The combined stresses σ_{Σ} , in MPa, in strength deck longitudinals, determined by Formula (3.1.4.1-1) shall not exceed $190/\eta$ in any section.

$$\sigma_{\Sigma} = \sigma_{sw} + \sigma_{ts} + k_{\Sigma} \sigma_w, \quad (3.1.4.1-1)$$

where: σ_{sw} – normal stresses, in MPa, in the section considered due to still water bending moment, determined by the formula

$$\sigma_{sw} = M_{sw} \cdot 10^3 / W_d^{\phi}; \quad (3.1.4.1-2)$$

where: for M_{sw} – , in kN/m, refer to **1.4.3**;

W_d^{ϕ} – actual hull section modulus in way of deck, as defined in 1.4.8 **1.4.8**;

σ_{ts} – normal stresses, in MPa, in the section considered due to the static torque M_{ts} (refer to **3.1.3.5**), determined by the formula

$$\sigma_{ts} = B_{ts} \bar{\omega} / (I_w \cdot 10^3), \quad (3.1.4.1-3)$$

where: B_{ts} – = bioment in considered section along the length of open part of the ship under the effect of the static torque M_{ts} , kN·m²;

$\bar{\omega}$ – main sectional area at the considered section point, in m²;

I_w – main sectional moment of inertia, in m⁶;

B_{ts} , $\bar{\omega}$, I_w – are determined according to the procedure approved by the Register;

σ_w – normal stresses, in MPa, in considered section due to vertical wave bending moment, determined by the formula

$$\sigma_w = M_w \cdot 10^3 / W_d^{\phi};$$

where: for M_w – refer to **1.4.4**;

k_{Σ} – factor by which vertical bend stresses are increased taking the horizontal bending and torque into account. It is determined by the formula:

$$k_{\Sigma} = \sqrt{1 + 0,15(0,85 + L / 600)^2 (\bar{\sigma}_h + \bar{\sigma}_{tw})^2};$$

$$\bar{\sigma}_h = \sigma_h / \sigma_w;$$

σ_h – normal stresses, in MPa, in considered section due to design horizontal wave bending moment, determined by the formula

$$\sigma_h = M_h \cdot 10^3 / W_{dz}^{\phi}; \quad (3.1.4.1-4)$$

where: for M_h – refer to **3.1.3.3**;

W_{dz}^{ϕ} – actual hull section modulus about the vertical axis through the centreline of the ship, in cm³, determined by the formula:

$$W_{dz}^{\phi} = I_z \cdot 10^2 / y;$$

I_z – actual inertia moment of the hull about the vertical axis, in cm²·m²;

y – half the ship's breadth in the considered section, in mm;

$$\bar{\sigma}_{tw} = \sigma_{tw} / \sigma_w;$$

σ_{tw} – total warping stresses, in MPa, under the effects of the torques M_{tw1} , M_{tw2} , M_{tw3} , determined by the formula

$$\sigma_{tw} = \sqrt{(\sigma_{tw_1} - \sigma_{tw_2})^2 + \sigma_{tw_3}^2}, \quad (3.1.4.1-5)$$

σ_{tw_i} – normal warping stresses, in MPa, under the effects of the torque M_{tw_1} , M_{tw_2} , M_{tw_3} (refer to 3.1.3.4), determined by the formula

$$\sigma_{tw_i} = \frac{B_i \bar{\omega}}{I_w \cdot 10^3}; \quad (3.1.4.1-6)$$

B_i – biomoments in considered section along the length of the open part of the ship under the effects of M_{tw_1} , M_{tw_2} , M_{tw_3} respectively, in kN/m². The biomoments are determined by the procedure approved by the Register.

3.1.4.2 Kinematic parameters of warping shall be determined.

The elongation of hatch opening diagonal under the effect of hull warping shall not exceed 35 mm. Where such elongation obtained by calculation is in excess of 35 mm, measures shall be taken for opening edge reinforcements. The calculation shall be made in accordance with the RS-agreed procedure.

3.1.4.3 Adequate buckling strength of the longitudinal deck strip between the supports as well as that of its items as regards the compressive stresses due to longitudinal bending shall be ensured.

3.1.4.4 Where the ratio of the length of the hatch opening to the width of the deck portion from the side shell to the longitudinal edge of the nearest hatch opening exceeds 10, calculation of shape deformation of the deck portion concerned in the horizontal plane in accordance with the procedure approved by the Register and use of the results obtained in assessment of the deck stressed state, design of hatch covers and side framing may be required.

3.1.4.5 The scantlings of cantilever beams and adjoining web frames shall satisfy the following requirements:

1 the section modulus, in cm³, of cantilever beam at a section in way of the end of a beam knee shall not be less than:

$$W = \frac{(0,5pal + Q)l\omega_k \cdot 10^3}{k_\sigma \sigma_n}, \quad (3.1.4.5.1)$$

where: p – intensity of design loads, in kPa, on the deck plating supported by the cantilever beam, as required by **3.1.3.7**;

a – distance between adjacent cantilever beams, in m;

l – span, in m, of a cantilever beam, measured from the section at the end of a beam knee to the hatch side coaming supported;

Q – design load, in kN, transmitted from hatch cover to the cantilever beam

$$Q = 0,5 p_1 a b_1,$$

where: p_1 – intensity of design loads, in kPa, on the cover of hatch adjoining the cantilever beam as required by **3.1.3.7**;

b_1 – width, in m, of opening for a hatch adjoining the cantilever beam;

$k_\sigma = 0,6$;

ω_k – as defined in **1.1.5.3**.

The sectional area of the web of cantilever beam shall not be less than that determined according to **1.6.4.3** taking:

$k_\tau = 0,6$;

$N_{\max} = pal + Q$ – for the section at the end of the beam bracket;

$N_{\max} = Q$ – for the section in way of the hatch side coaming adjoining the cantilever beam;

2 the section modulus of the web frame connected to the upper deck cantilever beam at the section in way of the end of the beam bracket shall not be less than that determined by Formula (3.1.4.5.1).

The section modulus of the web frame connected to the cantilever beam of the lower deck and fitted below that deck at the section in way of the end of the beam bracket shall comply with the same requirement but may be reduced by the value of section modulus of the web frame fitted above that deck, at the section in way of the end of the bracket adjoining the deck.

3.1.4.6 The scantlings of container securing arrangements shall be determined on the basis of strength calculations using the design loads complying with the requirements of **3.1.3.8**, and the resulting stresses shall not exceed the permissible ones determined using the permissible stress factors:

$$k_{\sigma} = k_{\tau} = 0,75.$$

The strength of hull structures taking up forces from the container securing arrangements shall be verified by calculation of the effects produced by these forces, and the resulting stresses shall not exceed the permissible ones specified in Section 2 for the appropriate structures.

3.2 ROLL-ON/ROLL-OFF SHIPS

3.2.1 General and symbols.

3.2.1.1 The requirements of this Chapter apply to ro-ro ships, ro-ro passenger ships and are supplementary to those of Sections 1 and 2.

These requirements also apply to decks and double bottoms of ships carrying wheeled vehicles for use in cargo handling.

3.2.1.2 For the purpose of this Chapter the following symbols have been adopted:

Q_0 – static load on the axle of the wheeled vehicle, in kN;

n_0 – number of wheels on an axle;

n – number of wheels forming a design load spot (for a single wheel $n = 1$);

u – size of a tyre print normal to the axis of rotation, in m;

v – size of a tyre print parallel to the axis of rotation, in m;

e – spacing between adjacent tyre prints, in m;

l_a – design load spot dimension parallel to the smaller side of the panel (directed across framing members), in m;

l_b – design load spot dimension parallel to the larger side of the panel (directed along framing members), in m;

a, b – smaller and larger sides of panel, respectively, in m;

l – span of the considered girder between supports, in m (refer to **1.6.3.1**).

3.2.2 Construction.

3.2.2.1 Vehicle decks and double bottoms of ro-ro ships and car ferries shall, in general, be longitudinally framed.

3.2.2.2 Movable decks fitted temporarily for the carriage of vehicles shall be so fixed as to prevent these decks from taking up longitudinal forces under the hull longitudinal bending.

The Rules provide for movable deck structure consisting of a top decking with a web structure and longitudinals welded thereto.

3.2.3 Loads from wheeled vehicles.

3.2.3.1 The design loads shall be based on specification details of vehicles carried on board the ship and used for cargo handling. The design documentation submitted to the Register for the consideration shall include static load on vehicle axle, number of wheels on the axle, wheel spacing, tyre print dimensions and tyre type.

Where wheel print details are not initially available, the requirements of **3.2.3.5** shall be applied.

3.2.3.2 The design load spot dimensions l_a and l_b shall be chosen as the overall dimensions of the print of a wheel group consisting of a maximum number of wheels and complying with the following conditions:

when determining the required plating thickness, the prints of all the wheels in a group shall be arranged within the panel surface (i.e. $l_a \leq a$ i $l_b \leq b$ – refer to Table 3.2.3.2);

when determining the section modulus and cross section of a main framing girder, the prints of all the wheels of a group shall be fully arranged within the surfaces of two panels adjacent to the girder under consideration (i.e. $l_a \leq 2a$ i $l_b \leq l$ – refer to Table 3.2.3.2).

The wheels may be united in a group irrespective of the distance between prints provided the overall dimensions of the group are in accordance with the above limitations.

Where two positions of the design load spot are possible (along and across main framing), $l_b \geq l_a$ shall be adopted as the design case (i.e. the spot positioned with its larger side along main framing).

Table 3.2.3.2 Procedures for choosing design load spot dimensions when establishing deck plating thickness

Wheel prints	Design load spot
	<p>$n = 1$</p>
	<p>$n = 2$</p>
	<p>$n = 3$</p>
	<p>$n = 1$</p>

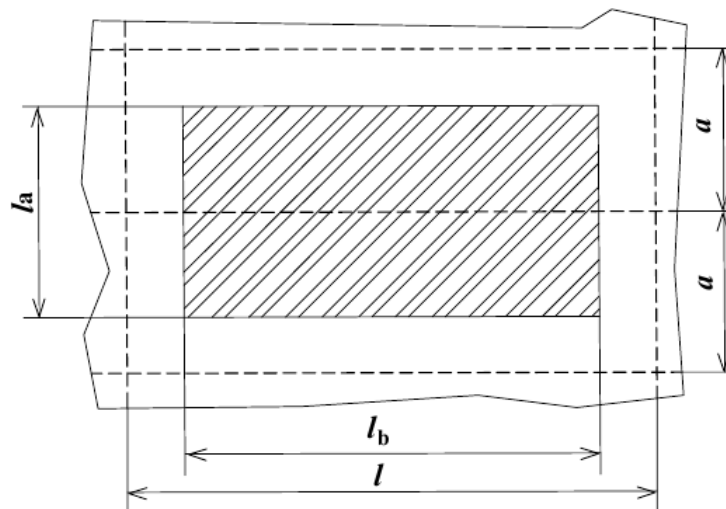

Fig.3.2.3.2 Design load spot dimension for main framing

3.2.3.3 To be considered are the loads resulting from the operation of vehicles during cargo handling operations and from stowage of vehicles on the deck under conditions of the ship motions.

3.2.3.4 The design load Q , in kN, shall be determined by the formula

$$Q = k_d Q_0 \cdot (n/n_0), \quad (3.2.3.4)$$

where: $k_d = \alpha_1 \cdot \alpha_2$ – dynamic coefficient in the process of operation of vehicles used for cargo handling operations;

α_1 – factor equal to: 1,10 and 1,05 for vehicles (except fork lift trucks) having an axle load less than 50 kN and 50 kN and more, respectively; 1,0 for fork lift trucks;

α_2 – factor equal to: 1,03 and 1,15 for pneumatic and cast-rubber tyres, respectively; 1,25 for wheels with a steel rim;

$k_d = 1 + a_z/g$ – dynamic factor characterizing the ship motions;

a_z – acceleration in the ship section under consideration in accordance with **1.3.3.1**.

Where distribution of the load between wheeled vehicle axles is not uniform, the maximum axle load shall be taken as the design load. For fork lift trucks it is assumed that the total load is applied to the forward axle.

3.2.3.5 Where specifications on tyre print dimensions are not available, the tyre print dimension normal to the wheel axle u , in m, shall be determined by the formulae:

for wheels with cast tyres

$$u = 0,01 Q_0/n_0, \quad \text{where } Q_0/n_0 \leq 15 \text{ kN}; \quad (3.2.3.5-1)$$

$$u = 0,15 + 0,001 \cdot [(Q_0/n_0) - 15], \quad \text{where } Q_0/n_0 > 15 \text{ kN};$$

for wheels with pneumatic tyres

$$u = 0,15 + 0,0025 Q_0/n_0, \quad \text{where } Q_0/n_0 \leq 100 \text{ kN}; \quad (3.2.3.5-2)$$

$$u = 0,4 + 0,002[(Q_0/n_0) - 100], \quad \text{where } Q_0/n_0 > 100 \text{ kN}.$$

The tyre print dimension of a wheel parallel to the wheel axle v , in m, shall be determined by the formula:

$$v = Q_0/(n_0 p_k), \quad (3.2.3.5-3)$$

where: p_k – static specific pressure, in kPa, to be adopted from Table 3 3.2.3.5.

Table 3.2.3.5

Vehicle	p_k	
	Pneumatic tyres	Cast tyres
Cars	200	-
Lorries, motor vans	800	-
Trailers	800	1500
Fork lift trucks	800 (where $n = 1$)	1500
	600 (where $n \geq 2$)	1500

3.2.3.6 If the size of wheel prints is adopted in accordance with **3.2.3.5**, the design load Q shall be increased by 15 %

3.2.3.7 The design load for train rails Q , in kN, shall be determined by the formula:

$$Q = 0,5 k_d Q_0 n_1, \quad (3.2.3.7)$$

where: $k_d = 1,1$ if the vehicle moves about during cargo-handling operations;

$k_d = 1 + a_z/g$ – in case of the ship motions;

a_z – acceleration in considered ship section in accordance with **1.3.3.1**;

n_1 – number of vehicle wheels arranged within the design span of framing member supporting railways.

3.2.3.8 The design loads for side shell and permanent deck primary members shall be those to satisfy the most severe stowage arrangement of all cargoes carried on deck (including package cargo, containers, wheeled

vehicles, etc.) and to allow for static and inertia forces resulting from the ship motions. Accelerations shall be determined in accordance with **1.3.3.1**.

3.2.3.9 The design load Q , in kN, for the transverses and girders of movable decks shall be determined by the formula

$$Q = k_d (p_c + p_d) a_2 l, \quad (3.2.3.9)$$

where: k_d – as defined in **3.2.3.4**;

p_c – static deck loads from the cargo carried, in kPa;

p_d – static deck loads from deck own mass, in kPa;

a_2 – mean spacing of transverses and girders, in m.

for l – refer to **3.2.1.2**.

The value of $(p_c + p_d)$ shall not be taken less than 2,5 kPa.

3.2.4 Scantlings of deck and side shell structures.

3.2.4.1 The thickness of plating s , in mm, shall not be less than

$$s = [17Qk_o/(l_a l_b R_{eH} k_1 k_2 k_3)]^{0.6} + 2, \quad (3.2.4.1)$$

where: Q – as defined under **3.2.3**;

k_o – factor accounting for the effects of total hull bend:

$k_o = 1/(1,4 - 0,8W/W_d^\phi) \geq 1$ – for the upper (strength) deck amidships with loads acting at sea;

$k_o = 1$ – elsewhere;

$k_1 = 0,83/\sqrt{a}$;

$k_2 = (0,84/\sqrt{l_a}) - 0,185$;

$k_3 = (0,18/l_b) + 0,38$;

W_d^ϕ – actual hull section modulus for deck in accordance with **1.4.8**.

3.2.4.2 The section modulus W of longitudinals and beams, in cm^3 , shall not be less than obtained from **1.6.4.1** with:

Q – as defined under **3.2.3**;

$m = 5,84/\{[1 - 0,57l_b/l]k_a\}$;

$k_a = 1 - 0,204(l_a/a)^2 + 0,045(l_a/a)^3$;

$k_\sigma = 0,8/k_o$ – for cargo handling operations in port;

$k_\sigma = 0,7/k_o$ – with loads applied at sea;

k_o – factor defined in **3.2.4.1**.

3.2.4.3 The web cross-sectional area f_c , in cm^2 , of beams and longitudinals shall not be less than obtained from **1.6.4.3** with:

$$N_{\max} = Qk_a(1 - 0,47l_b/l); \quad (3.2.4.3)$$

$k_\tau = k_\sigma$,

where: Q – as defined under **3.2.3**;

k_a and k_σ – factors defined in **3.2.4.2**.

3.2.4.4 The plating thickness, section modulus and cross-sectional area of beams and longitudinals of movable decks shall be determined in accordance with **3.2.4.1**, **3.2.4.2** and **3.2.4.3**. Where beams and longitudinals are freely supported by girders and transverses, the factor m shall be determined by the formula:

$$m = 8/[k_a(2 - l_b/l)], \quad (3.2.4.4)$$

where: k_a – factor defined in **3.2.4.2**.

Otherwise, the factor m shall be determined as for beams and longitudinals of permanent cargo decks according to **3.2.4.2**.

3.2.4.5 The section modulus of longitudinals W , in cm^3 , supporting fixed rails shall not be less than

obtained from **1.6.4.1** with:

Q – as defined under **3.2.3.7**;
 m to be determined by the formula

$$m = 5,85 / [(1 - k_5 e_2) / l], \quad (3.2.4.5)$$

where: $k_5 = 0$ with $n_1 = 1$;

$k_5 = 0,5n_1$ with $n_1 \geq 2$;

for n_1 – refer to **3.2.3.7**;

e_2 – = mean spacing of centres of wheels arranged within the design member span, in m;

$k_\sigma = 0,7/k_\sigma$;

k_σ – factor determined by **3.2.4.1**.

3.2.4.6 The scantlings of deep members of sides and permanent cargo decks, as well as of pillars shall be derived by direct calculation using the procedures approved by the Register.

3.2.4.7 The section modulus of the girders and transverses of movable decks W , in cm^3 , shall not be less than obtained from **1.6.4.1** with:

Q – as defined in **3.2.3.9**;

$m = 12$ – for fixed members;

$m = 8$ – for freely supported members;

$k_\sigma = 0,7$.

3.2.5 Special requirements.

3.2.5.1 A side fender protecting the ship side and stern from damage during mooring operations shall be fitted at the lower cargo deck level of ferries.

3.2.5.2 A longitudinal shall be fitted under each rail on the cargo decks of train ferries.

3.2.5.3 Where train decks with rails which are flush with the deck plating are provided on ships carrying railway carriages, the actual section modulus and sectional area of deck transverses shall be determined for the section located in the rail recess. Structural continuity of the effective flange of the deck transverse, where it intersects the rail, shall be ensured.

3.2.5.4 Where rails for the transport of railway carriages are welded to the deck plating throughout the entire length, the rail butts shall be welded with full penetration.

3.3 BULK CARRIERS AND OIL OR BULK DRY CARGO CARRIERS

3.3.1 General.

3.3.1.1 The requirements of this Chapter apply to bulk carriers and combination carriers intended for the carriage of bulk cargoes and crude oil, and not covered by the requirements of **1.1.1.1** of this Chapter and which shall comply with the requirements of IACS Common Structural Rules for Bulk Carriers and Oil Tankers ».

3.3.1.2 The scantlings of structural members bounding the cargo region shall be determined as required by Sections **1** and **2** on assumption of the carriage of bulk or liquid cargo (water ballast) in the holds primarily designed for the purpose concerned. The value to be adopted is the greater of the appropriate strength characteristics of the item.

3.3.1.3 The requirements for the structures not mentioned in this Chapter shall be as given in Sections **1** and **2**.

In any case, the requirements for the hull and its structures shall not be less stringent than those stated in Sections **1** and **2**.

3.3.1.4 The basic structural type of ships is considered to be a single-deck ship with machinery aft, having a flat (or nearly a flat) double bottom in the holds (permissible slope of the inner bottom from the side to the centreline is not over 3°), hopper side and topside tanks, single or double skin sides, transverse hold bulkheads of plane, corrugated or cofferdam type, which is primarily intended for bulk cargoes.

3.3.1.5 In combination carrier the length of the holds shall not exceed $0,1L$.

It is assumed that when carrying heavy bulk cargo, certain holds remain empty, their numbers shall be indicated in column "Other characteristics" in Classification Certificate as stated in **2.3**, Part I "Classification".

3.3.1.6 Descriptive notation and distinguishing mark (ESP).

3.3.1.6.1 The descriptive notation Bulk carrier and the distinguishing mark (ESP) shall be assigned to sea going self-propelled single deck ships with a double bottom, hopper side tanks and topside tanks and with single or double skin side construction intended primarily for carriage of dry cargoes in bulk. Typical midship sections are given in Fig. 3.3.1.6.1, refer also to definition «Bulk carrier» in 1.2.1 Part I «Classification».

Bulk carrier of single skin side construction means a bulk carrier where one or more cargo holds are bound by the side shell only or by two watertight boundaries, one of which is the side shell, which are:

less than 760 mm apart in bulk carriers, the keels of which are laid or which are at a similar stage of construction before 1 January 2000;

less than 1000 mm apart in bulk carriers, the keels of which are laid or which are at a similar stage of construction on or after 1 January 2000.

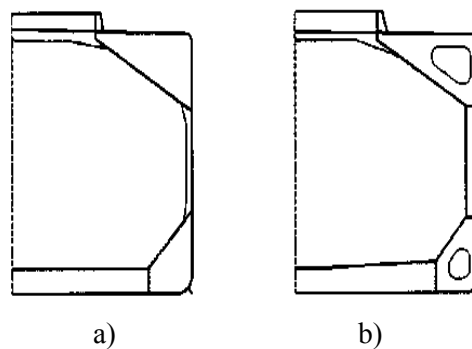

Fig. 3.3.1.6.1

3.3.1.6.2 The descriptive notation **Oil/Bulk/Ore carrier** and the distinguishing mark (ESP) shall be assigned to single deck ships of double skin side construction, with a double bottom, hopper side tanks and topside tanks fitted below the upper deck intended for the carriage of oil or dry cargoes, including ore, in bulk.

A typical midship section is given in Fig. 3.3.1.6.1.

3.3.1.6.3 The ship type descriptive notation Self-unloading bulk carrier and the distinguishing mark (ESP) shall be assigned to sea-going self-propelled ships which are constructed generally with single deck, double bottom, hopper side tanks and topside tanks and with single or double side skin construction in cargo length area and intended to carry and self-unload dry cargoes in bulk.

Typical midship sections are given in Fig. 3.3.1.6.3.

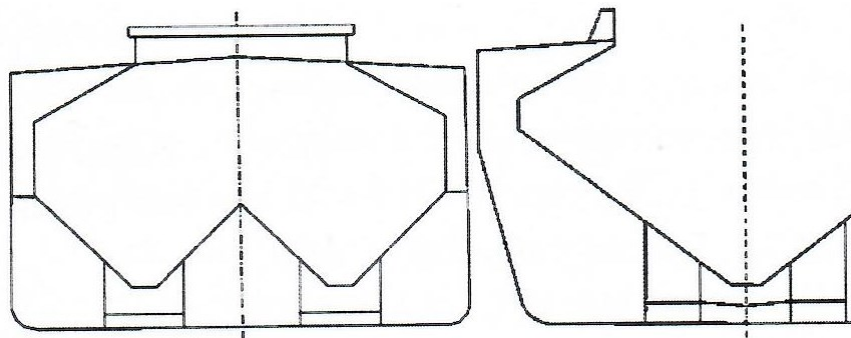

Fig. 3.3.1.6.3

3.3.2 Construction.

3.3.2.1 Longitudinal framing shall be adopted for the deck, the side shell in way of topside tanks and the sloped bulkheads of topside tanks. The deck plating between end coamings of adjacent cargo hatches shall be additionally strengthened with intercostal transverse stiffeners fitted at every frame.

The double bottom shall be longitudinally framed. The double bottom structure in which all bottom and inner bottom longitudinals are replaced by side girders may be permitted (refer to 2.4.2.4.2).

The single skin side between topside and hopper side tanks shall be transversely framed.

Longitudinal or transverse framing may be adopted for the double skin side and in the hopper side tanks.

The transverse watertight bulkheads may be plane with vertical stiffeners, corrugated with vertical

corrugations or of a cofferdam type.

3.3.2.2 A hatch side coaming shall be fitted with horizontal stiffeners. At every alternate frame the coaming shall be stiffened with vertical brackets fitted between the coaming flange and the deck

3.3.2.3 The slope angle of topside tank walls to the horizontal axis shall not be less than 30°.

Inside topside tanks, in line with hold transverse bulkheads, diaphragms shall be fitted, the plating of which may generally have drain and access holes of minimum size. The plating of transverse bulkheads inside topside tanks shall be strengthened with stiffeners. The ends of vertical stiffeners shall be bracketed.

In topside tanks transverse beams shall be fitted in line with deck transverses.

To stiffen the plates of the tank vertical walls which are in line with the hatch side coaming, brackets shall be placed inside the tanks in line with every stay of side coaming. These brackets shall be extended to the deck and tank sloped bulkhead longitudinals nearest to the centreline.

At every frame, in the lower corner of the tank, brackets shall be fitted in line with the brackets attaching the hold frame to the sloped bulkhead of the tank. These brackets shall be carried to the ship's side and tank sloped bulkhead longitudinals nearest to the lower corner of the tanks and welded to them so as to extend beyond the brackets of frames.

3.3.2.4 The slope angle of hopper side tank walls to the horizontal shall not be less than 45°. The extension of the tank over the ship breadth at the inner bottom level shall generally not be less than $0,125B$ on one side.

Transverse diaphragms shall be fitted in line with transverse bulkheads and every alternate plate floor. The diaphragms may have drains and access holes. The total height of openings at the section of diaphragm, in the direction along the normal to the tank plating, from a line drawn through the opening centre perpendicularly to that normal, to the plating shall not exceed 0,5 of the height of that section anywhere. The opening edges shall be reinforced with face plates or stiffeners. The diaphragm plating shall be stiffened as required by **1.7.3.2** for the floor stiffeners.

Inside longitudinally framed tank, brackets shall be fitted in line with every frame. These brackets shall be carried to the sloped bulkhead and side longitudinals and welded to them so as to extend beyond the brackets of frames.

At the outboard side girder forming transversely framed hopper side tank wall, brackets shall be fitted in line with every frame. These brackets shall be carried to the nearest bottom and inner bottom longitudinals and welded to them.

3.3.2.5 Within the cargo area, the single-side structure shall comply with the following requirements:

.1 the scantlings of side hold frames immediately adjacent to the collision bulkhead shall be increased in order to prevent excessive imposed deformation on the shell plating. As an alternative, supporting structures shall be fitted which maintain the continuity of fore peak stringers within the foremost hold;

.2 frame ends shall be attached with brackets. The vertical dimension of the lower and upper brackets, as measured at shell plating, shall not be less than 0,125 of the frame span. On the level of the frame adjoining the bilge and underdeck tank, the breadth of the lower and upper brackets shall not be less than half the web height;

.3 frames shall be fabricated symmetrical sections with integral upper and lower brackets and shall be arranged with soft toes. The end brackets adjoining the underdeck and bilge tanks shall be blunted, and the flange ends shall be sniped. The side frame flange shall be curved at the connection with the end brackets. The radius of curvature shall not be less than r , in mm, determined by the formula:

$$r = 4b_{br}^2 / s_{br} \quad (3.3.2.5.3)$$

where: b_{br} – the flange width, in mm;

s_{br} – the thickness of brackets, in mm;

.4 normal steel frames may be asymmetric. The face plates or flanges of brackets shall be sniped at both ends. The brackets shall be arranged with soft toes;

.5 where, a frame being connected to an underdeck tank, the frame or its bracket overlaps with a horizontal section of an inclined wall, provision shall be made for the bracket to go over the bent section, and the angle between the plane of the face plate (bracket) and the inclined tank wall shall not be less than 30°;

.6 the web depth to thickness ratio of frames shall not exceed the following values:

$60\sqrt{\eta}$ – for symmetrically flanged frames;

$50\sqrt{\eta}$ – for asymmetrically flanged frames;

.7 the outstanding flange shall not exceed $10\sqrt{\eta}$ times the flange thickness;

.8 in way of the foremost hold, side frames of asymmetrical section shall be fitted with tripping brackets which shall be welded to shell plating, webs and face plates of frames;

.9 double continuous welding shall be adopted for the connections of frames and brackets to side shell, hopper wing tank plating and web to face plates. For this purpose, the strength factor α for a weld (refer to 1.7.5.1) is adopted equal to:

0,44 - where frame webs shall be welded to shell plating on lengths equal to 0,25 of the frame span as measured from the upper and lower frame end, and where bracket webs shall be welded to the plating of underdeck and bilge tanks;

0,4 - where frame webs shall be welded to shell plating outside the above end sections.

Where the hull form is such as to prohibit an effective fillet weld, edge preparation of the web of frame and bracket may be required, in order to ensure the same efficiency as the weld connection stated above.

3.3.2.6 The ends of plane bulkhead stiffeners shall be bracketed to the inner bottom plating and to deck structures.

3.3.2.7 The cofferdam bulkheads shall satisfy the following requirements:

.1 the construction of cofferdam bulkheads, as stipulated under **2.7.1.2**, shall consist of two tight platings, diaphragms and/or platforms. To stiffen the plating, vertical or horizontal stiffeners may be fitted;

.2 the vertical or horizontal stiffeners of both platings shall be identical, form a ring structure and pass continuous through the platforms or, accordingly, diaphragms. The vertical stiffeners of both platings shall be fitted in the same plane parallel to the centreline of the ship; the horizontal stiffeners shall be fitted in the same plane parallel to the base line of the ship.

Cross ties are permitted between the vertical or horizontal stiffeners of both platings, at the mid-span thereof;

.3 the diaphragms or platforms shall be stiffened in accordance with **1.7.3.2**. The smaller side, in mm, of the panel of diaphragm or platform to be stiffened shall not exceed $100s\sqrt{\eta}$, where s is the thickness of diaphragm or platform, in mm;

.4 for access to all parts of the cofferdam bulkhead an adequate number of openings (manholes) shall be provided in the diaphragms and platforms. The total width of openings in one section of the diaphragm or platform shall not exceed 0,6 of the cofferdam bulkhead thickness.

Openings other than the air and drain scuppers are generally not permitted:

in the platforms, at a distance not less than 1,5 times the cofferdam bulkhead thickness from the longitudinal bulkheads or side, which act as the platform supports;

in the diaphragms, at the same distance from the inner bottom plating or the upper point of the bulkhead bottom trapezoidal stool, if any, and the upper deck plating or the lower point of the horizontal underdeck stiffener of rectangular or trapezoidal section, being the bulkhead top stool, if any, which act as the diaphragm supports.

Edges of the openings cut in the diaphragms and platforms located within 1/4 of the span from their supports shall be reinforced with face plates or stiffeners. The distance between the edges of adjacent openings shall be not less than the length of these openings.

3.3.2.8 Transverse bulkheads with vertical corrugations shall have plane areas at ship's sides not less than $0,08B$ in width. The upper ends of these bulkheads shall be attached to the deck by horizontal stiffeners of rectangular or trapezoidal section, complying with the requirements of **3.3.2.11**, while the lower ends shall be attached directly to the inner bottom plating or to the stools of trapezoidal section fitted on the inner bottom, complying with the requirements of **3.3.2.10**. The bulkheads in heavy cargo holds shall be supported by trapezoidal stools.

At lower end of corrugations there shall be fitted vertical and sloped plates so as to cover the concave portion of corrugations on each side of the corrugated bulkhead. The height of the covering plates in oil or bulk dry cargo carriers shall not be less than 0,1 of the corrugation span, and their thickness shall be not less than the lower strake thickness of the corrugation.

3.3.2.9 Where lower ends of vertical corrugations are attached directly to the inner bottom plating, floors the thickness of which shall be not less than that of the bottom strake of the corrugated bulkheads shall be aligned with transverse faces (those directed athwart the ship).

In this case, web plates (those directed along the ship) of rectangular corrugations shall be in line with inner bottom longitudinals or side girders. Side faces of trapezoidal corrugations shall be arranged so that in way of their intersection with inner bottom longitudinals hard spots are avoided.

3.3.2.10 The construction of the transverse bulkhead bottom trapezoidal stool shall comply with the following requirements:

.1 the stool is fitted on the inner bottom athwart the ship under the bulkhead. It shall consist of a top horizontal plate having a width not less than the height of the bulkhead corrugations and two sloped plates resting upon the plate floors. The height of the stool shall not exceed $0,15D$;

.2 inner bottom longitudinals shall be cut at the floors giving support to the sloped plates of the bottom stools and to be attached to them by brackets. Brackets having a thickness not less than that of the floors, reinforced with stiffeners shall be fitted between the floors in line with the inner bottom longitudinals;

.3 diaphragms shall be fitted inside the bottom stools in line with the centre girder and side girders. Drain and access holes may be cut in the diaphragms. Size of the openings, their runreinforcement as well as stiffening of diaphragms shall comply with similar requirements for the diaphragms of hopper side tanks, as specified in **3.3.2.4**;

.4 the horizontal and sloped plates inside the bottom stool shall be stiffened to form a ring structure, fitted in line with the inner bottom longitudinals.

3.3.2.11 The construction of the corrugated bulkhead top stool of rectangular or trapezoidal section shall comply with the following requirements:

.1 the top stool shall be fitted under the deck athwart the ship, over the bulkhead. It shall consist of a bottom horizontal plate having a width not less than the height of the bulkhead corrugations and two vertical or sloped plates. The height of the top stool shall be approximately equal to 0,1 of the distance between the topside tanks. The dimensions of the top stool shall be such as to provide access into that stool;

.2 the horizontal and vertical (sloped) plates inside the stool shall be stiffened.

The stiffeners may be fitted in line with the deck longitudinals forming ring structures with them.

Horizontal stiffeners may be fitted. In this case, webs giving intermediate support to these stiffeners as well as brackets ensuring efficient end attachment of corrugations shall be provided inside the top stool;

.3 where an angle between the sloped plate of the top stool and a vertical axis exceeds 30° , brackets ensuring efficient upper end attachment of corrugations shall be fitted inside the top stool in line with plane faces of trapezoidal corrugations.

3.3.3 Design loads.

3.3.3.1 The design loads on the inner bottom members, sides and transverse bulkheads shall be calculated as required by **2.2.3**, **2.4.3**, **2.5.3** and **2.7.3** respectively, taking account of the heaviest of the anticipated bulk cargoes, liquid cargo (water ballast) or empty holds, whichever is appropriate.

3.3.3.2 The design pressure on the plating and framing of the hopper side tank sloped sides and of the plates of the transverse bulkhead bottom stools shall be determined as required by **1.3.4.3** for the heaviest of the anticipated bulk cargoes and as required by **1.3.4.2** for liquid cargo, whichever is appropriate. In any case, the design pressure need not be taken less than that determined by Formula (1.3.4.2.1-4), and for the trapezoidal stools also in accordance with **2.7.3.1**.

3.3.3.3 The design pressure on the plating and framing of the topside tank longitudinal bulkheads and of the plates of the transverse bulkhead top stools of rectangular or trapezoidal section shall be determined as required by **1.3.4.2** for the holds filled with liquid cargo (water ballast). In any case, the design pressure need not be taken less than that determined by Formula (1.3.4.2.1-4), and for the top stools also in accordance with **2.7.3.1**.

3.3.3.4 Where the hopper side and/or topside tanks, transverse bulkhead bottom and/or top stools, space inside the cofferdam bulkheads and/or inter-skin space are used as tanks, the design pressure shall be determined with regard for the pressure from the inside as required by **1.3.4.2**.

3.3.4 Scantlings of structural members.

3.3.4.1 The scantlings of double bottom members shall satisfy the following requirements:

.1 the scantlings of centre girder, side girders and floors shall be determined on the basis of strength calculation made for bottom grillages using design pressure stated in **3.3.3** and the following permissible stress factors:

for centre girder and side girders:

$k_\sigma = 0,3k_b \leq 0,6$ – in the midship region, when determining the shell plating stresses;

$k_\sigma = 0,35k_b \leq 0,6$ – in the midship region, when determining the inner bottom plating stresses;

$k_\sigma = 0,6$ - at the ship's ends within $0,1L$ from the fore or after perpendicular.

For regions between the midship region and the above portions of ship's ends, k_σ shall be determined by linear interpolation;

for floors:

$k_\sigma = 0,6$;

when the strength is verified using the shear stresses $k_t = 0,6$.

k_b shall be determined by Formula (2.2.4.1).

Where combinations of empty and loaded holds are envisaged, this shall be accounted for in the strength calculation made for the bottom grillage when determining the root flexibility factor of the centre girder and side girders on the bearing contour line of the grillage. Account may be taken of the end root flexibility of floors owing to rotational stiffness of the hopper side tanks. The grillage shall be treated as a system of cross members (structural idealization using beam models).

For ships of 150 m in length and upwards, intended to carry solid bulk cargoes having a density of 1,78 t/m³ or above, and with:

single side skin construction; or

double side skin construction in which any part of longitudinal bulkhead is located within $B/5$ or 11,5 m, whichever is less, inboard from the ship's side at right angle to the centreline at the assigned summer load line;

contracted for construction on or after 1 July 2006, the strength of double bottom structural members in the case when each cargo hold considered individually flooded shall be additionally checked according to the procedure specified in Appendix 4;

.2 the section modulus of the bottom primary members shall be determined in accordance with **2.4.4.5** taking the following permissible stress factors:

for longitudinals

$k_\sigma = 0,4k_b \leq 0,65$ – in the midship region;

$k_\sigma = 0,65$ - at the ship's ends within $0,1L$ from the fore or after perpendicular.

For regions between the midship region and the above portions of ship's ends, k_σ shall be determined by linear interpolation;

for transverse members

$k_\sigma = 0,65$.

k_b shall be determined by Formula (2.2.4.1);

.3 the section modulus of inner bottom primary members shall be determined in accordance with **2.4.4.5** at the design pressure in accordance with **3.3.3** and the following permissible stress factors:

for longitudinals

$k_\sigma = 0,5k_b \leq 0,75$ – in the midship region;

$k_\sigma = 0,75$ - at the ship's ends within $0,1L$ from the fore or after perpendicular.

For regions between the midship region and the above portions of ship's ends, k_σ shall be determined by linear interpolation.

for transverse members

$k_\sigma = 0,75$.

k_b shall be determined by Formula (2.2.4.1).

3.3.4.2 the scantlings of the hopper side tank members shall comply with the following requirements:

.1 the thickness of the sloped bulkhead plating shall not be less than that determined by Formula (1.6.4.4) taking:

$m = 15,8$;

p – design pressure as defined in **3.3.3**;

k_σ shall be taken as for the longitudinal bulkhead plating of tankers as required by **2.7.4.1**, but not more than for the inner bottom plating in accordance with **2.4.4.4.1**.

The bottom strake thickness of the tank sloped bulkhead shall not be less than that of the inner bottom plate adjacent to it. The thickness of other strakes, in mm, shall not be less than

$$s_{\min} = (0,035L + 7)\sqrt{\eta}, \quad (3.3.4.2.1)$$

where: η – shall be obtained from Table 1.1.4.3,

but not greater than the bottom strake thickness.

Where the hold and/or tank is used for the carriage of oil, oil products or water ballast, the thickness shall not be less than required by **3.5.4**;

.2 the section modulus of primary members of the sloped bulkhead shall not be less than that determined in accordance with **1.6.4.1** and **1.6.4.2** taking:

p – design pressure as defined in **3.3.3**;

$m = 10$ – for transverse stiffeners;
 $m = 12$ – for longitudinal stiffeners;

k_{σ} shall be taken as for the bulkhead stiffeners of tankers as specified in **2.7.4.2**, but not more than for the inner bottom primary members in accordance with **3.3.4.1.3**.

The longitudinal stiffeners shall comply with buckling strength requirements, as specified in **1.6.5.2**;

.3 the thickness of the diaphragm plating shall not be less than that of the abutting plate floors. Stiffening of the diaphragms with openings shall comply with the requirements for stiffeners of the floors, as specified in **1.7.3.2**.

The thickness of plating and the scantlings of the stiffening framing members of the watertight diaphragms shall comply with the requirements for the tank bulkheads as specified in **2.7.4.1** and **2.7.4.2**.

3.3.4.3 Where the frame ends are attached directly to the sloped bulkheads of tanks (without transition horizontal area), the section modulus at support section W_{sup} , in cm^3 , shall be not less than

$$W_{sup} = W_o / \cos^2 \alpha, \quad (3.3.4.3)$$

where: W_{sup} – section modulus at the frame support section as required by **2.5.5.1**, in cm^3 ;
 α – slope angle of the tank bulkhead to the base line, in deg.

3.3.4.4 The scantlings of the frames shall be in accordance with the requirements of **2.5.4.1** and with the following requirements:

.1 the thickness of frame webs s_{wmin} , in mm, shall not be less than:

$$s_{wmin} = k(0,03L + 7), \quad (3.3.4.4.1)$$

where: $k = 1,15$ – for frame webs in way of the foremost hold,
 $k = 1,0$ – for frame webs in way of other holds;

.2 the thickness of the bracket connecting the lower end of frame to the bilge tank shall not be less than that of the frame web or $s_{wmin} + 2$ mm, whichever is greater. The thickness of the bracket connecting the upper end of frame to the underdeck tank shall not be less than that of the frame web.

.3 the section modulus of the frame and bracket or integral bracket, and associated shell plating, shall not be less than twice the section modulus required for the frame mid-span area.

3.3.4.5 The scantlings of the topside tank members shall comply with the following requirements:

.1 the plating thickness of the vertical and sloped bulkheads of the topside tank shall not be less than determined by Formula (1.6.4.4) taking:

$m = 15,8$;

p – design pressure as defined in **3.3.3**;

k_{σ} shall be taken as for the longitudinal bulkhead plating of tankers as specified in **2.7.4.1**.

The thickness, in mm, of the vertical bulkhead plating and of the adjoining sloped bulkhead plate shall not be less than

$$s_{min} = 0,025L + 10. \quad (3.3.4.5.1)$$

The thickness of other sloped bulkhead plates shall be not less than that determined by Formula (2.7.4.1-2). Where the hold and/or tank is used for the carriage of oil, oil products or water ballast, the thickness shall be not less than that required by **3.5.4**;

.2 the section modulus of longitudinal stiffeners of the vertical and sloped bulkheads shall not be less than that determined according to **1.6.4.1** taking

p – design pressure as defined in **3.3.3**, but not less than 25 kPa;

$m = 12$;

k_{σ} shall be taken as for horizontal stiffeners of longitudinal bulkheads of tankers as specified in **2.7.4.2**.

The longitudinal stiffeners of the vertical and sloped bulkheads shall comply with buckling strength requirements of **1.6.5.2**;

.3 the section modulus of the transverse web of the sloped bulkhead shall be not less than that determined in **1.6.4.1** and **1.6.4.2**, and the sectional area of the web plate shall not be less than that determined in accordance with **1.6.4.3** taking:

$N_{max} = 0,5pa$;

p – design loads as defined in **3.3.3**, but not less than 25 kPa;

$$m = 10;$$

$$k_{\sigma} = k_{\tau} = 0,75;$$

.4 the section modulus and sectional area of the deck transverse web inside the tank shall comply with the requirements of **2.6.4.6**.

The section modulus and sectional area of the side transverse web inside the tank shall comply with the requirements of **2.5.4.5** at $m = 10$.

The section modulus and sectional area of vertical web plate of the tank vertical bulkhead shall be calculated as the mean of these values for the deck transverse and transverse web of the sloped bulkhead;

.5 the plate thickness of bulkheads inside the tanks fitted in line with the hold transverse bulkheads shall not be less than that of the latter at the same distance from the inner bottom plating. Stiffening of bulkhead plating shall comply with the requirements of **2.7.4.2** for the tank primary members;

.6 the thickness of brackets stiffening the tank vertical bulkhead and of brackets fitted at the lower corner of the tank shall not be less than 10 mm.

3.3.4.6 In any case, the hold bulkhead plating and corrugations shall have a thickness not less than 10 mm.

The height of top rectangular (trapezoidal) stool, bottom trapezoidal stool and of double bottom is not included in the span of the hold bulkhead vertical corrugations.

3.3.4.7 The scantlings of the transverse bulkhead lower trapezoidal stool members shall comply with the following requirements:

.1 the thickness of the horizontal and sloped plate shall not be less than that determined by Formula (1.6.4.4) taking:

$$m = 15,8;$$

p – design pressure as defined in **3.3.3**;

$$k_{\sigma} = 0,9.$$

The thickness of horizontal plate and top strake of the sloped plate shall not be less than that of the corrugation adjoining the stool. The thickness of the bottom strake of the sloped plate shall not be less than that of the inner bottom plating. The thickness of other stakes of the sloped plate shall not be less than that determined by Formula (3.3.4.2.1). Where the hold and/or stool is used for the carriage of oil, oil products or water ballast, the thickness shall be not less than that required by **3.5.4**;

.2 the section modulus of the sloped plate stiffeners shall not be less than that determined in accordance with **1.6.4.1** and **1.6.4.2** taking:

p – design pressure as defined in **3.3.3**;

$$m = 10;$$

$$k_{\sigma} = 0,75.$$

The section modulus of the horizontal plate stiffeners shall not be less than that of the sloped plate stiffeners;

.3 the thickness of diaphragm shall not be less than that of side girders. Size of the openings cut in diaphragms and their reinforcement shall comply with the requirements for openings and reinforcement of the hopper side tank diaphragms as specified in **3.3.4.2.3**.

3.3.4.8 The scantlings of the transverse bulkhead top rectangular or trapezoidal stool members shall comply with the following requirements:

.1 the thickness of the horizontal and vertical (or sloped) plates shall not be less than that determined by Formula (1.6.4.4) taking:

$$m = 15,8;$$

p – design pressure as defined in **3.3.3**;

$$k_{\sigma} = 0,9.$$

The thickness of the horizontal plate and bottom strake of the vertical (sloped) plate shall not be less than that of the corrugation adjoining the top stool. Where the vertical plate is fitted in line with the hatch end coaming, its thickness shall not be less than that of this coaming as required by **3.3.4.11**. The top strake of the sloped plate shall have the same thickness provided that its upper edge is at a distance of less than 0,4 m from the hatch end coaming. In any case, the thickness of the vertical or sloped plate shall not be less than that determined by Formula (2.7.4.1-2). Where the hold and/or interior of the top stool is used for the carriage of oil, oil products or water ballast, the thickness shall not be less than that required by **3.5.4**;

.2 the section modulus of the stiffeners of vertical or sloped plate shall not be less than that determined according to **1.6.4.1** and **1.6.4.2** taking:

p – design pressure as defined in **3.3.3**, but not less than 25 kPa;

$m = 12$ – for horizontal stiffeners;

$m = 10$ – for other stiffeners;

$k_{\sigma} = 0,75$.

The section modulus of the stiffeners of horizontal plate shall not be less than that of the stiffeners of vertical or sloped plate;

.3 the section modulus of the vertical or sloped plate web to be fitted where horizontal stiffeners are provided, as stated in **3.3.2.11.2**, shall not be less than that determined from **1.6.4.1** and **1.6.4.2**, while the sectional area of the web plate shall not be less than determined according to **1.6.4.3** taking:

$N_{\max} = 0,5pal$;

p – design loads as defined in **3.3.3**, but not less than 25 kPa;

$m = 10$;

$k_{\sigma} = k_{\tau} = 0,75$.

The section scantlings of webs fitted on the horizontal plate and under the deck shall not be less than those required for the vertical (sloped) plate web;

.4 the thickness of the brackets fitted inside the top stool to ensure efficient upper end attachment of corrugations shall not be less than that of these corrugations in the upper part of the bulkhead.

3.3.4.9 The scantlings of the cofferdam bulkhead members shall comply with the following requirements:

.1 the thickness of the cofferdam bulkhead plating shall not be less than that determined by Formula (1.6.4.4) taking:

$m = 15,8$;

p – design pressure as defined in **3.3.3**;

$k_{\sigma} = 0,9$.

The plating thickness shall not be less than that determined by Formula (2.7.4.1-2) or according to **3.3.4.6**, whichever is the greater. Where the hold or interior of the cofferdam bulkhead is used for the carriage of oil, oil products or water ballast, the plating thickness shall be not less than that required by **3.5.4**;

.2 the section modulus of primary members stiffening the plating of cofferdam bulkheads shall not be less than that determined from **1.6.4.1** and **1.6.4.2** taking:

p – design pressure as defined in **3.3.3**, but not less than 25 kPa;

$m = 12$;

$k_{\sigma} = 0,75$;

.3 where the construction of the cofferdam bulkhead incorporates only diaphragms or only platforms, their section modulus shall not be less than that determined from 1.6.4.1 and 1.6.4.2, and the sectional area is not less than that determined from 1.6.4.3 taking:

$N_{\max} = 0,50pal$ – for platforms,

$N_{\max} = 0,65pal$ – for diaphragms;

p – design loads as defined in **3.3.3**, but not less than 25 kPa;

l – span, in m, equal to:

for diaphragms – the distance between the deck plating and inner bottom plating, at the centreline;

for platforms – the ship's breadth in way of construction bulkhead for ships having single skin side construction, the distance between the inner skins for ships having double skin side construction;

$m = 10$;

$k_{\sigma} = k_{\tau} = 0,75$;

.4 where the construction of the cofferdam bulkhead consists both the diaphragms and platforms, their thickness shall be determined on the basis of the calculation of the grillage as a system using beam models, with the loads specified in **3.3.3** but not less than 25 kPa and the permissible stress factors $k_{\sigma} = k_{\tau} = 0,75$;

.5 in any case, the thickness of the cofferdam bulkhead diaphragms and platforms shall not be less than that determined by Formula (2.5.4.8.1).

Where the interior of the cofferdam bulkhead is used as a fuel oil or ballast tank, the thickness of the diaphragms and platforms shall not be less than that required by **3.5.4**;

.6 stiffening of the diaphragms and platforms shall comply with the requirements of **1.7.3.2.2**;

.7 the thickness of tight portions of the diaphragms and platforms and their stiffeners shall comply with the requirements of **2.7.4.1** and **2.7.4.2** for tank bulkheads;

.8 cross ties between the primary members strengthening the cofferdam bulkhead plating shall comply with the requirements for the double bottom intermediate struts, as specified in **2.4.4.7** with the design pressure determined according to **3.3.3**, but not less than 25 kPa.

Where cross ties are fitted, the section modulus of the primary members, as specified in **3.3.4.9.2**, may be reduced by 35%.

3.3.4.10 For ships of 150 m in length and upwards, intended to carry solid bulk cargoes having a density of 1,78 t/m³ or above, and with:

single side skin construction; or

double side skin, in which any part of longitudinal bulkhead is located within B/5 or 11,5 m, whichever is less, inboard from the ship's side at right angle to the centerline at the assigned summer load line;

contracted for construction on or after 1 July 2006, the strength of vertically corrugated transverse watertight bulkheads in the case when each cargo hold considered individually flooded shall be additionally checked according to the procedure specified in Appendix 3.

3.3.4.11 The thickness of the hatch coamings shall not be less than that determined by Formula (3.3.4.4.1).

The thickness of the hatch side coamings, in mm, shall not be less than

$$s = 17a, \quad (3.3.4.11)$$

where: a – vertical distance between horizontal stiffeners on coaming plate or between the lower stiffener and the deck plating, in m.

Stiffening of the coaming plates shall comply with the requirements of **1.7.3.2**. The thickness of coaming plate stiffeners and brackets shall not be less than 10 mm.

The width of the coaming face plate shall comply with the requirements of **1.7.3.1**.

3.3.4.12 The thickness of single-side shell plating located between hopper and upper wing tanks shall not be less than s_{\min} , in mm, determined by the formula

$$s_{\min} = \sqrt{L}. \quad (3.3.4.12)$$

3.3.5 Special requirements.

3.3.5.1 Provision shall be made for an efficient corrosion protection coating (epoxy coating or equivalent) for all internal surfaces of the cargo holds, excluding the flat tank top areas and the hopper tanks sloping plating, approximately 300 mm below the toe of frame brackets and for all internal and external surfaces of hatch coamings and hatch covers. In the selection of coating due consideration shall be given to intended cargo conditions expected in service.

3.3.5.2 All bulk carriers of 150 m in length and upwards contracted for construction on or after 1 July 2003, shall comply with the following requirements:

.1 the longitudinal strength shall be checked at departure and arrival of the ship for loading conditions specified in 1.4 and also for the following conditions:

*for bulk carriers with **BC-A**, **BC-B** or **BC-C** distinguishing marks in the class notation:*

homogeneous cargo loaded condition where the cargo density corresponds to all cargo holds, including hatchways, being 100 % full at maximum draught with all ballast tanks empty;

*for bulk carriers with **BC-A** or **BC-B** distinguishing marks in the class notation:*

homogeneous cargo loaded condition with cargo density 3,0 t/m³, and the same filling ratio (cargo mass/hold cubic capacity) in all cargo holds at maximum draught with all ballast tanks empty;

*for bulk carriers with **BC-A** distinguishing mark in the class notation:*

- at least one cargo loaded condition with specified holds empty, with cargo density 3,0 t/m³, and the same filling ratio (cargo mass/hold cubic capacity) in all loaded cargo holds at maximum draught with all ballast tanks empty;

- normal ballast (no cargo) condition, where the ballast tanks may be full, partially full or empty, any cargo hold or holds adapted for the carriage of water ballast at sea shall be empty, the trim shall be by the stern and shall not exceed 0,015L, where L is the length between perpendiculars of the ship, the propeller shall be fully immersed;

- normal ballast (no cargo) condition, where all ballast tanks are 100 % full, other conditions - refer to the previous case;

- heavy ballast (no cargo) condition, where the ballast tanks may be full, partially full or empty, at least one cargo hold adapted for carriage of water ballast at sea shall be full, the trim shall be by the stern and shall not exceed 0,015L, where L is the length between perpendiculars of the ship, the moulded forward draught in the heavy ballast condition shall not be less than the smaller of 0,03L or 8 m, whichever is the less, the propeller

immersion I/D shall be at least 60 % where I = the distance from propeller centerline to the waterline, D = propeller diameter;

– heavy ballast (no cargo) condition where all ballast tanks are 100 % full, other conditions _ refer to the previous case.

At departure condition: with bunker tanks not less than 95 % full and other consumables 100 %; and at arrival condition: with 10 % of consumables;

.2 the structures of bottom forward shall meet the requirements of 2.8;

.3 for calculation of local strength of double bottom (vertical keel, bottom stringers and floors) the following definitions and symbols shall apply:

M_H - the actual cargo mass in a cargo hold corresponding to a homogeneously loaded condition at maximum draught;

M_{Full} - the cargo mass in a cargo hold corresponding to cargo with virtual density (homogeneous mass/hold cubic capacity, minimum 1,0 t/m³) filled to the top of the hatch coaming, and M_{Full} shall in no case be less than M_H ;

M_{HD} - maximum cargo mass allowed to be carried in a cargo hold with specified holds empty at maximum draught;

.4 local strength of double bottom in each cargo hold shall be checked, inter alia, for the following cases of load on the double bottom due to cargo mass in the holds, as well as mass of fuel oil and water ballast contained in double bottom tanks, as well as sea water pressure along the hold.

General conditions applicable for all ships:

- cargo mass M_{Full} , fuel oil tanks being 100 % full, ballast water tanks being empty, at maximum draught;

- cargo mass minimum 50 % of M_H , fuel oil tanks and ballast water tanks being empty, at maximum draught;

- any cargo hold being empty, fuel oil tanks and ballast water tanks being empty, at the deepest ballast draught;

except the ships when the entry (no MP) is added to the class notation after the distinguishing marks:

- cargo mass M_{Full} , fuel oil tanks being 100 % full, ballast water tanks being empty, at 67 % of the maximum draught;

- any cargo hold, fuel oil tank and ballast water tank being empty, at 83 % of the maximum draught;

- cargo mass M_{Full} in each of two adjacent holds, fuel oil tanks being 100 % full, ballast water tanks being empty, at 67 % of the maximum draught. Applicable also in case when the adjacent hold is filled with ballast;

- two adjacent cargo holds being empty, fuel oil tanks and ballast water tanks being empty, at 75 % of the maximum draught;

applicable only for ships with BC-A distinguishing mark in the class notation:

- cargo holds intended to be empty at maximum draught and fuel oil tanks and ballast water tanks are being empty;

- cargo mass $M_{HD}+0,1M_H$ in cargo holds intended to be loaded with high density cargo, fuel oil tanks being 100 % full, ballast water tanks being empty, at maximum draught. In operation maximum allowable cargo mass shall be limited to M_{HD} ;

- cargo mass 10 % of M_H in each of two adjacent cargo holds which may be loaded with the next holds being empty, fuel oil tanks being 100 % full, ballast water tanks being empty, at maximum draught;

for ballast hold(s) only:

- cargo holds being 100 % full of ballast water including hatchways, fuel oil tanks and ballast tanks being 100 % full, at any heavy ballast draught;

during loading and unloading in harbour only:

- maximum allowable cargo (sea-going) mass in any single cargo hold, at 67 % of the maximum draught;

- cargo mass M_{Full} in any two adjacent holds, fuel oil tanks being 100 % full, ballast water tanks being empty, at 67 % of the maximum draught;

- at reduced draught during loading and unloading in harbour, the maximum allowable mass in a cargo hold may be increased by 15 % of the maximum mass allowed at the maximum draught in sea-going condition, but shall not exceed the mass allowed at maximum draught in the sea-going condition.

3.3.5.3 Hull girder longitudinal strength for bulk carriers with:

single side skin construction,

double side skin construction in which any part of longitudinal bulkhead is located within B/5 or 11,5 m, whichever is less, inboard from the ship's side at right angle to the centreline at the assigned summer load line;

applicable for ships with **BC-A** or **BC-B** distinguishing marks in the class notation; which were contracted for construction on or after 1 July 2006, which were contracted for construction on or after 1 July 2006, shall be checked for specified flooded conditions, in each of the cargo and ballast loading conditions defined in **1.4.3.1** and **3.3.5.2**, except that harbour conditions, docking condition afloat, loading and unloading transitory conditions in port and loading conditions encountered during ballast water exchange need not be considered.

The actual hull girder bending stress σ_{fld} , in MPa, shall be determined by the formula

$$\sigma_{fld} = \frac{M_{sw}^{fld} + 0,8M_w}{W} \cdot 10^3, \quad (3.3.5.3-1)$$

where: M_{sw}^{fld} – still water bending moment, in kN/m, in the flooded conditions for the section under consideration; M_w – wave bending moment, in kN/m, as given in **1.4.4.1** for the section under consideration; W – section modulus, in cm^3 , for the corresponding location in the hull girder.

The actual hull girder shear stress τ_{fld} , in MPa, shall be determined by the formula

$$\tau_{fld} = \frac{N_{sw}^{fld} + 0,8N_w}{2s} \frac{S}{I} \cdot 10^3, \quad (3.3.5.3-2)$$

where: N_{sw}^{fld} – still water shear force, in kN, in flooded conditions for the section under consideration; N_w – wave shear force, in kN, as given in **1.4.4.2** for the section under consideration; I, S – as defined in **1.4.2**; s – thickness of side shell plating, in mm.

Strength calculation in flooded condition shall demonstrate that the actual hull girder bending stress shall not exceed $175/\eta$, in MPa, and the actual shear stress shall not exceed $110/\eta$, in MPa.

To calculate the strength in flooded condition, the following assumptions shall be made:

the damaged structure is assumed to remain fully effective in resisting the applied loading;

each cargo hold shall be considered individually flooded up to the equilibrium waterline. Position of the waterline and the volume of ingressed water are determined on the basis of damage trim and stability calculations which shall be made in accordance with a program approved by the Register;

"permeability" for solid bulk cargo means the ratio of the floodable volume between the particles, granules or any larger pieces of the cargo, to the gross volume of the bulk cargo;

the permeability of empty cargo spaces and volume left in loaded cargo spaces above any cargo shall be taken as 0,95;

appropriate permeabilities and bulk densities shall be used for any cargo carried. For iron ore, a minimum permeability of 0,3 with a corresponding bulk density of $3,0 \text{ t/m}^3$ shall be used. For cement, a minimum permeability of 0,3 with a corresponding bulk density of $1,3 \text{ t/m}^3$ shall be used;

for packed cargo conditions (such as steel mill products), the actual density of the cargo shall be used with a permeability of zero.

3.3.5.4 All the bulk carriers and combination carriers contracted for construction on or after 1 July 2003 shall comply with the following requirements:

.1 the ships shall have the forecastle located above the freeboard deck. In case the above requirement hinders hatch cover operation, the aft bulkhead of the forecastle may be fitted forward of the forward bulkhead of the foremost cargo hold provided the forecastle length is not less than 7 % of ship length abaft the forward perpendicular where the ship length - refer to Regulation 3 of the International Convention on Load Lines, 1966 (LL 66), as modified by the Protocol of 1988 relating thereto with further amendments (LL 66/88).

The forecastle shall have at least a standard height according to the International Convention on Load Lines, 1966 as amended by the Protocol of 1988 or shall be by 0,5 m above the forward hatch-end coaming of the fore hold No. 1, whichever is greater. In this case, the distance between the aft edge of the forecastle deck and the forward hatch-end coaming of the fore hold No. 1 over the entire breadth of the ship's hull shall not exceed the value, in m, determined by the formula

$$l_F = \sqrt{H_F - H_C}, \quad (3.3.5.4.1)$$

where: H_F - forecastle height, in m;

H_C - height of the forward hatch-end coaming of the fore hold No. 1, in m.

No breakwater is allowed on the forecastle deck for protection of the forward hatch-end coaming and hatch covers of the fore hold No. 1.

However, if fitted for other purposes, the breakwater shall be placed at a distance of at least 2,75 its height along the centerline from the aft edge of the forecastle deck;

.2 a net thickness (no wear allowance) of hatch coamings shall not be less than that determined by the formula

$$s_{net} = 14,9a\sqrt{1,15p_{coam}/0,95R_{eH}}, \quad (3.3.5.4.2)$$

where: a – distance between stiffeners, in m;

p_{coam} – pressure equal to 220 kPa; if the requirements of **3.3.5.2.1** are not met, the pressure for the forward hatch-end coaming of the fore hold No. 1 shall be assumed equal to 290 kPa.

The net thickness increased by 1,5 mm shall be taken as the minimum construction thickness.

In any event, the coaming thickness shall not be less than 11 mm;

.3 the section modulus of longitudinal and transverse stiffeners of hatch coamings at the net thickness of all section elements, in cm^3 , shall not be less than determined by the formula

$$W_{net} = \frac{1,15al^2 p_{coam}}{0,95m c_p R_{eH}} \cdot 10^3, \quad (3.3.5.4.3)$$

where: for a and p_{coam} – refer to **3.3.5.4.2**;

l – stiffener span, in m;

m – coefficient equal to:

16 – for snipped stiffener ends;

12 – in way of hatch corners;

c_p – plastic-to-elastic section modulus ratio for a stiffener with an effective flange $40s_{newidet}$, where s_{net} – net thickness of a coaming.

If precise data are lacking, c_p may be assumed equal to 1,16.

The net thickness of all cross-section elements increased by 1,5 mm shall be taken as the minimum construction thickness.

.4 stays (brackets) of hatch coamings shall comply with the following requirements:

the section modulus of stays (brackets) in the plane of beams with a net thickness of all section elements shall not be less than that determined by the formula

$$W_{net} = 500a H_C^2 p_{coam}/0,95R_{eH}, \quad (3.3.5.4.4-1)$$

where: a – distance between stays in the plane of beams, in m;

for p_{coam} – refer to **3.3.5.2.2**;

H_C – висота комінгса люка, м.

In determination of the actual section modulus, the face plate of the coaming stay may be considered only when it is welded to the deck plating with full penetration and appropriately dimensioned stiffeners, knees or brackets are fitted in its plane under the plating.

The net thickness of a web of stays in the plane of beams shall not be less than that determined by the formula

$$s_{net} = \frac{1000aH_c p_{coam}}{0,5hR_{eH}}, \quad (3.3.5.4.4-2)$$

where: h – depth of a stay web at its attachment to deck plating, in mm;

a and H_C – refer to Formula (3.3.5.4.4-1);

for p_{coam} – refer to **3.3.5.4.2**.

The net thickness of all cross-section elements increased by 1,5 mm shall be taken as the minimum construction thickness.

In strength calculations for stays off the plane of beams, the permissible stresses shall be assumed equal to 0,8 and 0,46 of the steel yield stress for normal and shear stresses accordingly.

The stay web shall be joined to deck plating by a double continuous weld having an effective throat

thickness not less than $0,44s$ where s is the minimum construction thickness of the stay web, in mm. At least 15 % of the weld length therewith beginning at the "free" end of the stay shall be made with deep penetration (double-bevel preparation).

The strength of underdeck structures taking forces from coaming stays shall be checked against permissible normal and shear stresses equal to 0,95 and 0,5 the steel yield stress accordingl;

.5 longitudinal and transverse stiffeners, stays and plate elements of cargo hatch coamings shall be replaced if the actual residual thickness of the coaming element is less than $t_{net} + 0,5$ mm.

Where the actual residual thickness is greater than $t_{net} + 0,5$ mm, but less than $t_{net} + 1,0$ mm, a protective coating instead of replacement may be applied in accordance with the manufacturer's procedure or annual measurements of the actual residual thickness may be conducted.

3.3.6 Strength control during ship loading.

3.3.6.1 Bulk carriers, ore carriers and combination carriers of 150 m length and above shall be provided with the Loading Manual and loading instrument approved by the Register.

3.3.6.2 Loading Manual is a document approved by the Register, which describes:

.1 the loading conditions on which the design of the ship has been based, including permissible limits of still water bending moments and shear forces;

.2 the results of the calculations of still water bending moments, shear forces and where applicable, limitations due to torsional loads;

.3 envelope results and permissible limits of still water bending moments and shear forces in the hold flooded condition according to **3.3.5.4**;

.4 the cargo holds or combination of cargo holds that might be empty at full draught. If no cargo hold is allowed to be empty at full draught, this shall be clearly stated in the Loading Manual;

.5 maximum allowable and minimum required mass of cargo and double bottom contents of each hold as a function of the draught at mid-hold position;

.6 maximum allowable and minimum required mass of cargo and double bottom contents of any two adjacent holds as a function of the mean draught in way of these holds. This mean draught may be calculated by averaging the draught of the two mid-hold positions;

.7 maximum allowable tank top loading together with specification of the nature of the cargo (density or stowage factor) for cargoes other than bulk cargoes;

.8 maximum allowable load on deck and hatch covers. If the ship is not approved to carry load on deck or hatch covers, this shall be clearly stated in the Loading Manual;

.9 the maximum rate of ballast change together with the advice that a load plan shall be agreed with the terminal on the basis of the achievable rates of change of ballast.

3.3.6.3 In addition to the requirements given in 1.4.3.1.1, the following conditions, subdivided into departure and arrival conditions as appropriate, shall be included in the Loading Manual:

.1 alternate light and heavy cargo loading conditions at maximum draught, where applicable;

.2 homogeneous light and heavy cargo loading conditions at maximum draught;

.3 ballast conditions. For ships having ballast holds adjacent to double bottom tanks, it shall be strengthwise acceptable that the ballast holds are filled when double bottom tanks are empty;

.4 short voyage conditions where the vessel shall be loaded to maximum draught but with limited amount of bunkers;

.5 multiple port loading/unloading conditions;

.6 deck cargo conditions, where applicable;

.7 typical loading sequences where the vessel is loaded from commencement of cargo loading to reaching full deadweight capacity, for homogeneous conditions, relevant part load conditions and alternate conditions where applicable. Typical unloading sequences for these conditions shall also be included. The typical loading/unloading sequences shall also be developed to not exceed applicable strength limitations. The typical loading sequences shall also be developed paying due attention to loading rate and the deballasting capability;

.8 typical sequences for change of ballast at sea, where applicable.

3.3.6.4 A loading instrument is an approved digital system as defined in **1.4.9.4**. In addition to the requirements in **1.4.9.4**, it shall ascertain as applicable that:

.1 the mass of cargo and double bottom contents in way of each hold as a function of the draught at mid-hold position;

.2 the mass of cargo and double bottom contents of any two adjacent holds as a function of the mean draught in way of these holds;

.3 the still water bending moment and shear forces in the hold flooded conditions according to **3.3.5.3**; are within permissible values.

3.3.6.5 Conditions of approval of loading instruments, as stated in 1.4.9.4, shall include the following:

- .1 acceptance of hull girder bending moment limits for all read-out points;
- .2 acceptance of hull girder shear force limits for all read-out points;
- .3 acceptance of limits for mass of cargo and double bottom contents of each hold as a function of draught;
- .4 acceptance of limits for mass of cargo and double bottom contents in any two adjacent holds as a function of draught.

3.4 ORE CARRIERS AND ORE OR OIL CARRIERS

3.4.1 General.

3.4.1.1 The requirements of this Chapter apply to ships for the carriage of ore and other bulk cargoes, as well as to combination carriers for transportation of ore and oil (petroleum products).

3.4.1.2 The requirements for structures not mentioned in this Chapter shall be as stated in Sections **1** and **2**, having regard to those contained in **3.3** as regards structures exposed to the loads from heavy dry bulk and liquid cargoes.

In any case, the requirements for the hull and its structures shall not be less stringent as those of Sections **1** and **2**.

3.4.1.3 The basic structural type of a ship is considered to be a single deck ship, with machinery aft, having longitudinal bulkheads separating the centre ore compartment from the wing tanks and a double bottom throughout the entire breadth of the ship or the centre part between the longitudinal bulkheads.

3.4.1.4 Descriptive notation and distinguishing mark (ESP).

3.4.1.4.1 The descriptive notation **Ore carrier** and the distinguishing mark (**ESP**) shall be assigned to sea-going self-propelled single deck ships having two longitudinal bulkheads and a double bottom throughout the cargo region and intended for the carriage of ore cargoes in the center holds only. A typical midship section is given in Fig. 3.4.1.4.1.

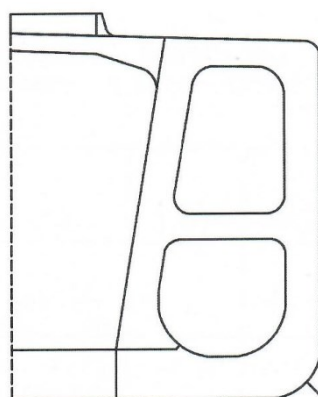

Fig. 3.4.1.4.1

3.4.1.4.2 Combination carrier is a general term applied to ships intended for the carriage of both oil and dry cargoes in bulk; these cargoes are not carried simultaneously, with the exception of oil retained in slop tanks.

3.4.1.4.3 The descriptive notation **Ore/Oil** carrier and the distinguishing mark (**ESP**) shall be assigned to sea-going self-propelled single deck ships having two longitudinal bulkheads and a double bottom throughout the cargo region and intended for the carriage of ore cargoes in the centre holds or of oil cargoes in centre holds and wing tanks. Typical midship sections are given in Fig. 3.4.1.4.3.

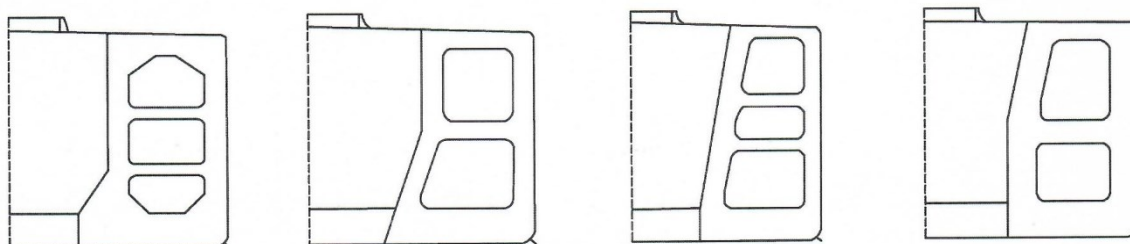

Fig. 3.4.1.4.3

3.4.2 Construction.

3.4.2.1 The deck and bottom (double bottom) shall be longitudinally framed. The side shell and longitudinal bulkheads may, in general, be framed either longitudinally or transversely.

Deck plating between end coamings of adjacent cargo hatches shall be strengthened by transverse stiffeners as required by **3.3.2.1**.

Transverse bulkheads may be plane with stiffeners arranged vertically, corrugated with vertical corrugations or of a cofferdam type.

3.4.2.2 Floors in the centre hold and in the wing tanks shall be aligned and to form, in conjunction with side transverses, vertical webs of longitudinal bulkheads and deck transverses, a single transverse ring structure.

3.4.2.3 Where transverse bulkheads in the wing tanks are not aligned with centre hold bulkheads, transverse ring structures shall be fitted in line with the latter bulkheads.

In this case, provision shall be made in the wing tanks for a smooth tapering of the sloped bulkheads of trapezoidal stools fitted under centre hold bulkheads.

3.4.2.4 Longitudinal bulkheads shall, in general, be plane with horizontal or vertical stiffening. Longitudinal bulkheads may be slightly sloped or to have a knuckle.

3.4.2.5 Where a double bottom in wing tanks is omitted, floors shall be backed by substantial knees or brackets fitted in line with the inner bottom plating of the centre hold.

3.4.2.6 Diaphragms shall be fitted in line with the longitudinal bulkheads inside the bottom trapezoidal stools and top stools of rectangular or trapezoidal sections.

The diaphragms of the bottom stools shall comply with the requirements of **3.3.2.10.3**, the diaphragms of the top stools - with the requirements for the topside tank bulkheads as specified in **3.3.2.3**.

3.4.3 Design loads.

3.4.3.1 The design pressure on the centre hold boundary structures shall be determined according to 1.3.4.3 assuming that the centre hold is loaded with ore or other heavy bulk cargo.

3.4.3.2 Structures which are likely to be subjected to one-sided pressure of a liquid cargo (ballast water) shall be examined for the design pressure of the liquid cargo as required by **1.3.4.2**.

3.4.4 Scantlings of structural members.

3.4.4.1 The scantlings of structural members of the cargo spaces intended only for the carriage of bulk cargoes or bulk cargoes and oil, oil products or water ballast shall comply with the requirements of Section 2 and **3.3.4**.

The scantlings of structural members of the cargo spaces intended only for the carriage of oil, oil products or water ballast shall comply with the requirements of Section 2 and **3.5.4**.

3.4.4.2 The scantlings of longitudinal bulkhead members shall comply with the requirements of **2.7.4** at the design pressure defined in **3.4.3**.

In any case, the thickness of longitudinal bulkhead plating shall not be less than that required by Formula (3.3.4.5.1) or, where oil, oil products or water ballast is carried in any compartment bounded by that bulkhead, it shall be not less than that required by **3.5.4**, whichever is the greater.

3.4.4.3 The scantlings of structural items of diaphragms of transverse bulkhead bottom trapezoidal stool, fitted in line with the longitudinal bulkheads, shall comply with the requirements of **3.3.4.7.3**.

3.4.4.4 The scantlings of structural items of diaphragms of transverse bulkhead top stool, fitted in line

with longitudinal bulkheads, shall comply with the requirements of 3.3.4.5.5 for the transverse bulkheads inside the topside tanks.

3.4.5 Special requirements.

3.4.5.1 All ore carriers shall have the forecastle located above the freeboard deck. The forecastle arrangement and dimensions, as well as the thickness and scantlings of stiffeners and plate elements of cargo hatch coamings shall meet the requirements of 3.3.5.4.

3.5 TANKERS

3.5.1 General.

3.5.1.1 The requirements of this Chapter apply to tankers, chemical tankers, as well as to oil recovery ships and gas carriers, as applicable, with machinery aft, having a single or a double bottom arrangement and one, two or three longitudinal bulkheads. Hull structural members of tankers not covered by this Chapter shall comply with the requirements of Sections 1 and 2.

Double hull oil tankers of 150 m in length and above, contracted for construction on and after 1 July 2015, shall comply with the requirements of 1.1.1.1.

3.5.1.2 Descriptive notation and distinguishing mark (ESP).

3.5.1.2.1 The descriptive notation **Oil tanker** and the distinguishing mark (**ESP**) shall be assigned to sea-going self-propelled ships having integral tanks and intended for the carriage of oil in bulk. The above mentioned descriptive notation and distinguishing mark shall be assigned to tankers of both single and double skin side construction, as well as tankers with alternative structural arrangements, e.g. mid-deck designs. Typical midship sections are given in Fig. 3.5.1.2.1.

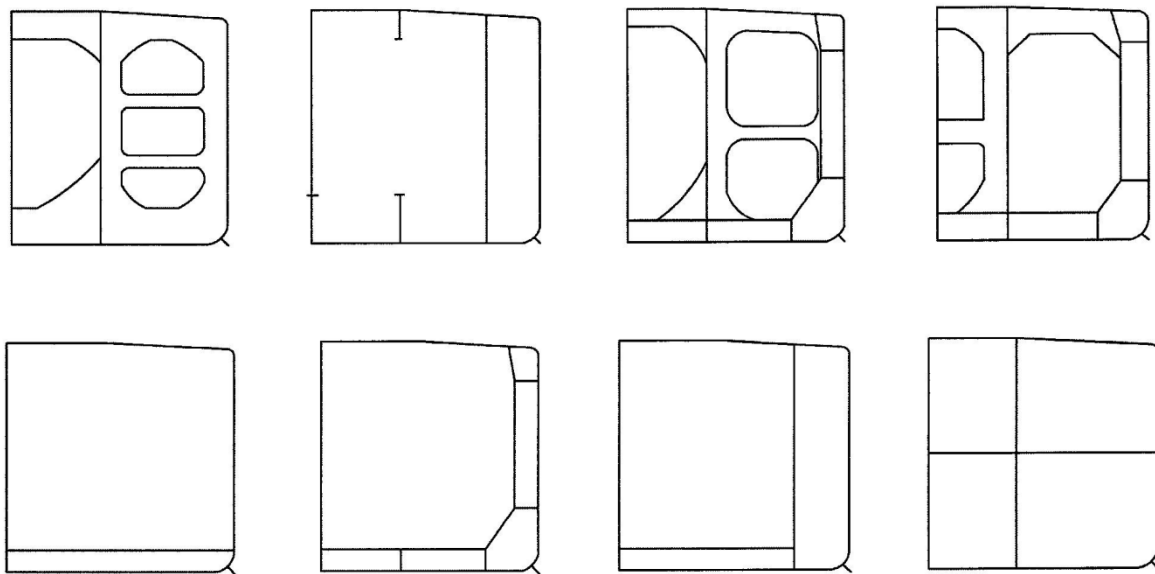

Fig 3.5.1.2.1

3.5.1.2.2 The descriptive notation **Chemical tanker** and the distinguishing mark (**ESP**) shall be assigned to sea-going self-propelled ships having integral tanks intended for the carriage of chemicals in bulk. This descriptive notation shall be assigned to tankers of both single or double skin side construction, as well as tankers with alternative structural arrangements. Typical midship sections are given in Fig. 3.5.1.2.2.

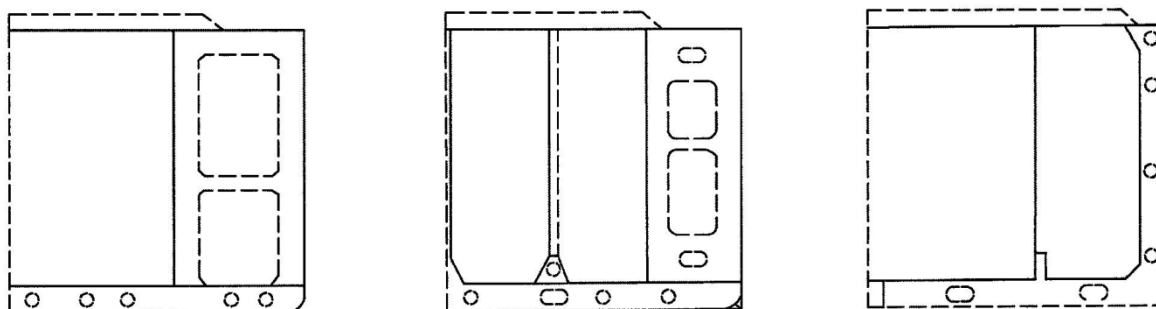

Fig. 3.5.1.2.2

3.5.2 Structural configuration.

3.5.2.1 The scantlings of the cofferdams shall be determined according to 2.7.5.2.

3.5.2.2 Longitudinal corrugated bulkheads are permitted in ships under 180 m in length.

Longitudinal corrugated bulkheads shall have horizontally arranged corrugations, and their upper and lower strakes for $0,1D$ from the deck and bottom, respectively, shall be plane.

In way of connections between longitudinal and transverse bulkheads, continuity of strength shall be maintained at the top and bottom strakes of the longitudinal bulkheads.

3.5.2.3 The deck and bottom in the cargo tank region shall be framed longitudinally, for the side shell and longitudinal bulkheads, longitudinal or transverse framing may be adopted.

The deck and bottom of ships under 80 m in length may be transversely framed.

It is recommended that longitudinal framing be used for side shell and longitudinal bulkheads of ships over 180 m in length.

Where the longitudinal framing is adopted, spacing of transverse members shall correspond to that of bottom transverses (refer to 2.3.2.4 and 2.4.2.5).

3.5.2.4 The longitudinal scantlings of deck, bottom, side shell and longitudinal bulkheads within the midship portion of the ship shall not vary. Structural continuity of the above longitudinals shall be ensured within $0,1D$ from deck and bottom.

In ships of 150 m in length and more, the above longitudinals shall pass through the transverse bulkheads without cutting.

3.5.2.5 The primary supporting members (bottom centreline girder, side girders, vertical webs on bulkheads, deck centreline girder, continuous deck girders, side and bottom transverses, side stringers and bulkhead horizontal girders) in way of cargo tanks shall form a transverse ring structure, whenever possible.

3.5.2.6 Hull structural members shall be interconnected as required by 1.7.2. The webs of primary supporting members shall be supported by horizontal or vertical stiffeners in accordance with 1.7.3.2. The inertia moment of stiffeners shall comply with 1.6.5.6.

3.5.3 Design loads.

Unless provided otherwise in this Chapter, the design loads on hull structures of tankers shall be taken according to 1.3 and relevant chapters of Section 2.

3.5.4 Scantlings of structural members.

The scantlings of structural members of tankers shall be determined in compliance with Section 2, having regard to the provisions of this Chapter.

The thickness s_{min} , in mm, of structural members, forming the boundaries of cargo and ballast tanks as well as members fitted inside these tanks shall not be less than:

$$s_{min} = 0,035L + 5,5, \quad \text{for } L < 80 \text{ m}; \quad (3.5.4)$$

$$s_{min} = 0,02L + 6,7, \quad \text{for } L \geq 80 \text{ m}.$$

Where $L > 290$ m, L shall be taken equal to 290 m.

In this case, the minimum thickness of the primary members need not exceed 11,5 mm.

3.5.5 Special requirement.

3.5.5.1 The number of openings for access to cofferdams, pump rooms, cargo and ballast tanks shall be

kept to the minimum required. They shall be as far distant as practicable from end bulkheads of superstructures. Hatches to wing tanks in line with a centre tank hatch in the athwart direction are not permitted.

Hatch openings shall be either circular or elliptical in shape, the elliptical openings having the major axis fore and aft. Structural continuity of deck girders and longitudinals shall be maintained. The thickness of cargo hatch coamings less than 750 mm high shall be 10 mm, while coamings 750 mm and more in height shall have a thickness equal to 12 mm. Coamings more than 750 mm in height, provided they are more than 1,25 m long, shall be stiffened.

3.5.5.2 Guard rails, bulwark, gangway or an equivalent arrangement shall be fitted in compliance with **8.6**, Part III "Equipment, Arrangements and Outfit".

The gangway, if fitted, shall not contribute to hull longitudinal bending.

3.6 DREDGERS, HOPPER BARGES, FLOATING CRANES, CRANE SHIPS

3.6.1 General.

3.6.1.1 The requirements of this Chapter apply to the hulls of the vessels of dredging fleet and floating cranes. Areas where such ships operate and/or transport spoil are called work areas. The transfer of the ship from one work area to another is called a voyage.

3.6.1.2 Industrial fleet includes dredgers, opening hopper dredgers, hopper barges, floating cranes and crane ships (refer to definitions in **1.2.1** Part, I «Classification»).

3.6.1.3 The basic structural configuration of a vessel of dredging fleet, considered in this Chapter, is a single-deck vessel with ordinary ship lines or of a pontoon shape, having a ladder well or other hull cut-outs.

The pontoon hull shape may be used only in vessels of restricted service **R2**, **R2-RS**, **R2-S**, **R3-RS**, **R3-S**, **R3-IN** and **R3**.

3.6.1.4 The requirements of this Chapter apply to dredgers, single-hulled and opening double-hulled hopper dredgers and hopper barges, floating cranes and crane ships.

3.6.1.4 In opening hopper dredgers and hopper barges, subject to the Register supervision are deck and deckhouse hinges, hydraulic presses and their hull connections as well as longitudinal and transverse structures between the hulls and deckhouses.

3.6.1.6 For the purpose of this Chapter the following symbols have been adopted:

d_1 – maximum dredging draught, in m, at which the vessel is designed to operate;

d_2 – draught during sea voyage, in m;

Δ – displacement at the draught d_1 or d_2 , in t;

Δ_l – light-ship displacement without spoil mixture, in m;

l_h – full length of the hopper, in m;

$h_{l.cr}$ – depth of a hopper lower cross-member, in m;

$l_{l.cr}$ – hopper lower cross-member span measured at mid-depth between longitudinal bulkheads of the hopper, in m;

H_1 – distance from the mid-depth of the hopper lower cross-member to the deck at side, in m;

H_2 – distance from the base line to the upper edge of the coaming, in m;

h_c – coaming height above the deck line at side, in m;

B_2 – distance between the side shell and the longitudinal bulkhead at mid-depth of a hopper lower cross-member, in m;

B_3 – distance between the side shell and the longitudinal bulkhead at the deck level, in m;

Q_s – maximum mass of the spoil mixture in the hopper, in t;

ρ_s – density of spoil mixture, defined as a ratio of the spoil mass in the hopper at the maximum draught d_1 to the hopper volume up to the level of overflow or to the upper edge of the hopper coaming where there is no overflow, in t/m³; it shall not be taken more than 1,8;

$A_{b,k}$, $A_{l.cr}$ – areas enveloped in the contour of the centre line box keel, hopper lower cross-member, respectively, in m²; where the centre line keel and/or a hopper lower cross-member are an ordinary girder (web with a face plate), it is assumed that $A_{b,k} = A_{l.cr} = 0$;

$b_{b,k}$ – centre line box keel width at lower portion, in m;

b_b – bottom breadth from the side shell to the point of intersection of the hopper longitudinal bulkhead with the bottom, in m;

$b_{f,p}$ – width of the coaming upper face plate, in m;

- a – spacing of frames, hopper side stiffeners, longitudinals, in m;
 b – spacing of transverse ring structures, in m;
 l_1, l_2 – length of the upper and lower face plate of the hopper lower cross-member, measured from the hopper longitudinal bulkhead to the centre line box keel, in m;
 $R_{up.cr}, R_{l.cr}$ – axial force acting on the hopper upper and lower cross-member, respectively, in kN;
 N – design axial force, in kN.
 Δs – corrosion allowance, in mm, for plate thickness (refer to 1.1.5.1);
 ω_c – factor taking corrosion allowance into account with regard to the section modulus of members (refer to 1.1.5.3).

Some of the symbols are shown in Fig. 3.6.1.6.

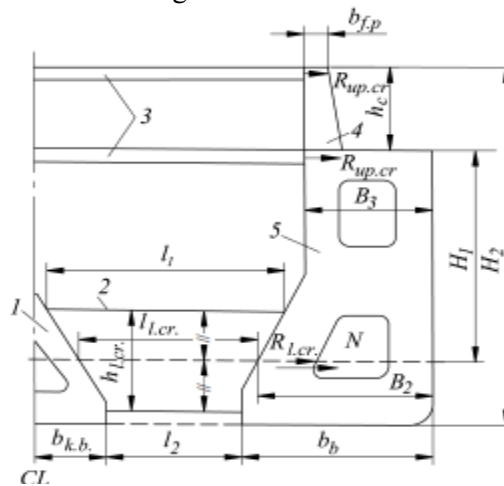

Fig. 3.6.1.6:

1 - centre line box keel; 2 - hopper lower cross member; 3 - hopper upper cross member; 4 - stay of coaming; 5 - diaphragm

3.6.2 Construction.

3.6.2.1 Main hull structures shall comply with the requirements of Section 2, having regard to the provisions and additions given in this Chapter.

Referred to the particular structures of vessels of dredging fleet are:

- hopper longitudinal and transverse bulkheads;
- hopper lower and upper cross-members;
- centre line box keels, hopper coamings;
- diaphragms and transverse ring structures in buoyancy spaces (refer to 3.6.2.11).

For floating cranes strengthening shall be provided of the pontoon hull beneath the fixed crane tower supporting the upper crane structure, this strengthening including the crane tub, the bulkhead cross and the bearing contour (refer to Fig. 3.6.2.1).

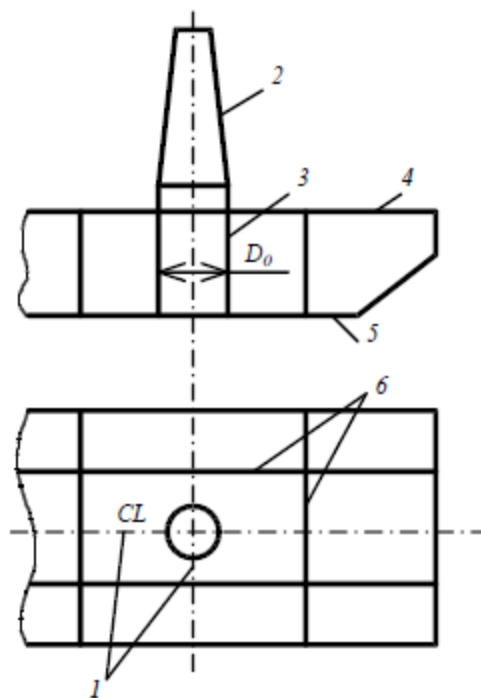

Fig. 3.6.2.1:

1 - bulkhead of the cross; 2 - fixed crane tower; 3 - tub; 4 - upper deck;
5 - bottom; 6 - bulkheads of the bearing contour

3.6.2.2 Shell plating.

3.6.2.2.1 Corners of hopper and well openings in the bottom plating shall be rounded. Insert plates shall be fitted at the corners.

3.6.2.2.2 The cutting of overflow discharge trunk openings in the sheerstrake shall be avoided wherever practicable. Where such openings cannot be dispensed with, their upper edge shall not be within 800 mm of the deck line at side. They shall have corner radii of not less than 150 mm.

3.6.2.2.3 Angular connection of the side shell plating or longitudinal bulkhead of the well with the bottom plating shall be made by means of section steel (rod, bar).

3.6.2.3 Single bottom.

3.6.2.3.1 The bottom centre girder in way of the hopper and well of hopper dredgers shall not be fitted.

3.6.2.3.2 The depth of floors abreast of hoppers in hopper dredgers and barges with transverse framing and abreast of dredging wells in hopper dredgers shall not be less than $1/18 B_1$.

The breadth B_1 is taken: in way of the hopper, equal to the breadth of the vessel after deducting the breadth of the hopper at bottom, but not less than $0,6B$; in way of the well, equal to the breadth of the vessel after deducting the breadth of the well.

3.6.2.3.3 Side girders shall be fitted in side buoyancy tanks of hopper dredgers and hopper barges where the tank width between the vessel's side and the longitudinal bulkhead exceeds 3,5 m in transversely framed vessels, and 4 m in longitudinally framed vessels.

Side girders in opening hopper barges may be omitted.

3.6.2.3.4 In the pump rooms of hopper dredgers, the bottom framing shall be identical to that of the engine room.

3.6.2.3.5 In floating cranes plate floors shall be fitted at every frame within $0,2L$ from the forward perpendicular over the entire breadth of the hull and additional bottom transverses or longitudinals spaced not more than 0,35 m apart shall be fitted.

3.6.2.4 Double bottom.

3.6.2.4.1 In lieu of the bottom centre girder, two side girders may be fitted on each side of ship's centre line at a distance not exceeding 1 m from each other and passing into the webs of the centre line box keel or into the well sides (refer to Fig. 3.6.2.4.1).

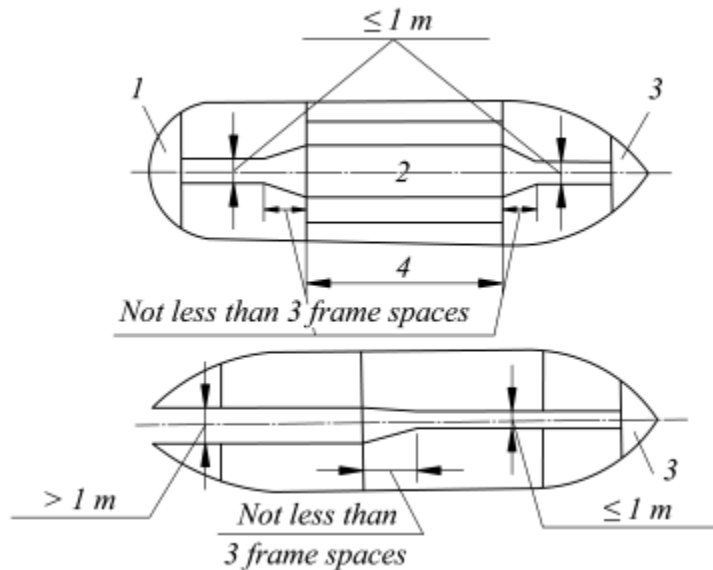

Fig. 3.6.2.4.1

1 - after peak; 2 - centre line box keel; 3 - fore peak; 4 - hopper space.

3.6.2.4.2 Additional side girders extending over a distance of not less than three spacings from the end of the bracket shall be fitted in the double bottom under the lower brackets of longitudinal bulkheads of the hopper space or the well and under the brackets of the centre line box keel.

3.6.2.5 Side framing.

3.6.2.5.1 In floating cranes, hopper dredgers designed to work in conjunction with hopper barges, and in hopper barges, the side framing shall be reinforced as follows:

two rows of efficient fenders, one fitted at the deck level or 200 mm below it, the other 200 to 300 mm above the lowest operating waterline amidships;

the upper and lower fenders in hopper dredgers shall be connected by vertical fenders fitted in line with frames;

it is recommended that a side stringer required by 2.5.4.4 which shall be taken into account in determining the scantlings of the frames or an intercostal side stringer be fitted at a level of the lower fenders.

3.6.2.5.2 In floating cranes the strengthening of the side framing within $0,2L$ from the forward perpendicular shall comply with the requirements of 3.6.2.8. Web frames shall be spaced not more than four spacings apart.

3.6.2.5.3 In floating cranes, intermediate frames of the same scantlings as the main frames shall be fitted in the fore peak and in areas extending forward for $0,1L$ from the stern transom and inboard for $0,1B$ over the entire depth. The extension and end attachments of intermediate frames shall comply with the requirements of 3.10.

3.6.2.6 Decks and platforms.

3.6.2.6.1 Corners of openings in the deck plating in way of the hopper and the well shall be rounded. Insert plates shall be fitted at the corners.

3.6.2.6.2 In hopper side buoyancy spaces, the hopper lower cross members shall be fitted in line with the web frames unless partial bulkheads are fitted.

3.6.2.7 Watertight bulkheads.

3.6.2.7.1 Bulkheads forming the ends of the hopper shall extend from side to side.

3.6.2.7.2 In bucket dredgers, protective bulkheads shall be provided parallel to the well sides at a distance of not less than 600 mm from them.

The extension of protective bulkheads shall be such as to prevent the ship from flooding in case of damage to the shell plating by objects brought up in the dredge buckets.

A protective bulkhead shall be also provided at the end of the well. The scantlings of framing members and the plating thickness of the protective bulkheads shall be determined as for permanent watertight bulkheads of dry cargo ships. The framing inside the cofferdam formed by the well side and the protective bulkhead may consist of brackets with openings cut therein. Cofferdams shall have access openings for maintenance.

3.6.2.7.3 Bulkheads forming the ladder well in hopper dredgers shall be protected against possible damage by the ladder when moved.

3.6.2.7.4 Longitudinal bulkheads of the hopper and well sides shall terminate at deck and bottom in brackets. The length of the arms of the brackets shall not be less than $0,25D$ and their thickness shall not be less than the plating thickness of the longitudinal bulkhead. The brackets shall be strengthened with stiffeners and to have a face plate over the free edge. The top bracket shall be extended by a deck girder, the bottom bracket by a side girder for at least three spacings beyond the bracket end.

3.6.2.7.5 In floating cranes the bulkheads forming the cross shall be rigidly connected with the bulkheads forming the bearing contour. These bulkheads shall be carried to the nearest transverse and longitudinal bulkheads (sides, transoms).

3.6.2.8 In ships with a pontoon shape of the forward and after ends, the following structural requirements shall be fulfilled:

.1 the fore and after peak bulkheads shall be fitted within the distance of $0,05L$ — $0,11L$ from the forward and after transoms accordingly, but not less than one spacing from the line connecting the sloped and flat bottom;

.2 frame spacing in peaks shall be not more than 550 mm;

.3 the bottom framing within $0,15L$ from the forward and after perpendiculars shall consist of plate floors fitted at every frame, with side girder spaced not more than 1 m apart.

The scantlings of floors and side girders shall be determined as for the midship region;

.4 the side framing within $0,2L$ from the forward and after perpendiculars shall be strengthened with web frames and side stringers.

The web frames shall be fitted not more than three or four spacings.

The side stringers shall be fitted so that the distance between the side stringers measured over the vessel's side in way of the floor nearest to the fore peak bulkhead, the distance from the side stringer to the upper edge of the floor, as well as from the side stringer to the deck is not more than 2 m.

The scantlings of main frames fitted between the web frames shall comply with the requirements of **3.6.4.7** as for the midship region where side stringers are not provided.

The side stringers shall have the same scantlings as the web frames and terminate at the bulkhead or at the web frame (refer to **2.5.4.7.2**).

Construction and end attachments of the web frames shall comply with the requirements of **2.5.5**;

.5 the transom bulkheads shall be strengthened with vertical stiffeners spaced not more than 0,5 m apart, and with horizontal girders arranged at the side stringer level.

Vertical webs shall be fitted in line with side girders. The scantlings of the vertical webs and horizontal girders shall be the same as those of web frames and side stringers in the fore peak. The scantlings of vertical stiffeners shall be the same as those of the frames. The attachments of stiffener ends with brackets shall comply with the requirements of **2.7.2** for watertight bulkheads.

3.6.2.9 Structural requirements for hull members of opening vessels.

3.6.2.9.1 Opening vessels consist of two separate semihulls with asymmetrical lines, connected by hinges positioned above the deck at the ends of the hopper. When discharging the spoil, the semi-hulls are opened about a common longitudinal axis on the centreline of the ship by means of hydraulic devices.

The structure of each semi-hull shall comply with the requirements of Section 2 with due regard for **3.6.2**; transverse or longitudinal or both framing systems may be adopted. In hopper side buoyancy tanks transverse ring structures spaced as required by **3.6.2.11.1** shall be fitted.

3.6.2.9.2 Where hinges are installed in opening hopper dredgers and hopper barges, deck plating and framing shall be strengthened. Hinge eyes shall pierce the decks.

3.6.2.9.3 Stops shall be fitted in the opening vessels between semi-hulls forward and aft from the hopper space. The stops shall be arranged at the levels of the bottom and the deck and shall prevent the hulls from displacement relative to one another.

3.6.2.9.4 Scantlings of brackets connecting framing members of each semi-hull shall comply with the requirements of **3.6.2.11.3**.

3.6.2.9.5 Longitudinal bulkheads and coamings of the hopper shall be extended with brackets as required by **3.6.2.7.4** and **3.6.2.11.7**.

3.6.2.10 Fixing of dredging gear.

3.6.2.10.1 Hull framing shall be strengthened in way of the main and ladder gallows.

The stanchions of the ladder gallows may terminate at the deck. In such case, pillars, vertical webs or other equivalent structures shall be provided under the stanchions or longitudinal and transverse bulkheads shall be fitted.

The stanchions of the main galleys shall extend to the bottom and be efficiently connected with longitudinal and transverse framing, otherwise transverse bulkheads shall be fitted under the stanchions.

3.6.2.10.2 In way of grab crane, spuds and other dredging gear adequate strengthening shall be provided.

3.6.2.11 Specific structures.

3.6.2.11.1 Whatever the hull framing of single-hull hopper dredgers and barges in way of the hopper is adopted, transverse ring structures consisting of the following items shall be fitted:

solid platforms or ring structures in the side buoyancy spaces and centre line box keel;

a lower cross member in the bottom part of the hopper, connecting the centre line box keel with longitudinal bulkheads of the hopper;

an upper cross member inside the hopper at a level of the main deck and upper edge of the coaming where its height more than 0,2 m (where the requirements of 3.6.4.11.10 are complied with, upper cross members need not be fitted);

vertical webs on the hopper coaming.

The maximum distance between transverse ring structures shall not be less than $b = (0,012L + 2,9)$ m.

3.6.2.11.2 The construction of diaphragms shall comply with the requirements of 2.5.2.2. Diaphragms which are more than 1 m in width shall be strengthened by vertical and horizontal stiffeners. Where longitudinal framing is adopted, horizontal stiffeners shall be fitted in line with side and bulkhead longitudinals. In lieu of the diaphragms watertight (non-tight) bulkheads complying with the requirements of 2.7.2 may be used.

3.6.2.11.3 The transverse ring structure in the side buoyancy space, fitted in lieu of the diaphragm, shall consist of side shell, bulkhead, bottom and deck transverses. The longitudinal bulkhead and side shell transverses shall be connected by means of cross ties which shall be so positioned that the distance between them, between a cross tie and a bottom or deck transverse is not more than 3 m. In lieu of the cross ties, use may be made of braces connecting a bulkhead transverse with a bilge or deck transverse bracket. Where platforms are fitted in side buoyancy spaces at the same distance as cross ties, cross ties and braces may be omitted.

The brackets connecting transverse ring structure items in the side buoyancy space shall have the length of the arms not less than one-twelfth of the greater span of the connected members. The free edge of the bracket shall have a face plate of the same width as that of the face plate of the greater member connected. The bracket thickness shall be equal to the web thickness of the greater member connected.

3.6.2.11.4 Hopper lower cross members may consist of a web with openings and face plates provided on the upper and lower edges or may take the form of a hollow box, generally of triangular cross-section.

The web thickness of the hopper lower cross member shall be taken equal to the plating thickness of the hopper longitudinal bulkheads at the corresponding level.

A cross member web shall be strengthened with stiffeners spaced 900 mm apart.

The upper face plate of the hopper lower cross member shall be made of a tube, section, round or flat bar, the lower face plate shall be fabricated of a flat bar having a thickness not less than that of the bottom plating.

The hopper lower cross members shall be connected with the hopper longitudinal bulkhead and centre line box keel by brackets having length of the arms equal to one-tenth of the length of the cross member upper face plate. The thickness of brackets shall be taken equal to the thickness of the cross member web. Where the depth of the cross member and centre line box keel is the same, brackets on the centre keel need not be fitted. The structure of box-type cross members is similar to that of the centre box keel. Where cross members are of a box shape, their lower and upper face plates shall be welded to the plating of the buoyancy spaces and centre line box keel.

3.6.2.11.5 The centre line box keel fitted in the hopper is generally fabricated as a closed box structure. The plating thickness of the sides shall be equal to that of hopper longitudinal bulkheads at the corresponding level, but not less than 8 mm for vessels of 60 m in length and less than 10 mm for vessels of more than 60 m in length. The thickness of the centre line keel bottom strake shall be not less than that of the plate keel. Where the transverse framing is adopted, the stiffeners in the upper part of the centre line box keel shall be connected with brackets, the thickness of which shall be not less than that of the floor and height not less than 2,5 times the depth of the stiffener web.

Where the breadth of the centre line box keel at bottom exceeds 1 m, but not more than 2 m, a bottom longitudinal shall be fitted on centre line box keel bottom, the depth of which shall be equal to half the floor depth. Where the breadth of the centre line keel is more than 2 m, an intercostal side girder having the same scantlings as the floor shall be fitted in lieu of the above longitudinal. The scantlings of floors are assumed the same as those of floors fitted in correspondingly framed buoyancy spaces.

On the top, the centre line box keel shall terminate in a bar, or an angle, or a cover plate, the thickness of which shall be equal to that of the centre line box keel.

The centre line box keel sides shall extend beyond the hopper transverse bulkheads by brackets, the arm lengths of which shall be equal to the depth of the centre line box keel, and the thickness equal to that of the centre line box keel side.

3.6.2.11.6 The upper cross members of the hopper space may consist of a web with openings and face plates on the upper and lower edges or be fabricated in the form of a hollow box generally of a triangular or another cross-section.

It is recommended that the upper cross members be attached to the hopper longitudinal bulkhead by brackets the arm lengths of which shall be equal to the depth of the upper cross member, and the thickness to its web thickness.

The upper cross members shall be connected to the centre line box keel by pillars, where such a keel is fitted.

3.6.2.11.7 The hopper coaming may be transversely or longitudinally framed. The upper edge of the coaming shall be stiffened with a face plate having a width not less than one-tenth of the coaming height and a thickness not less than a coaming thickness.

In case of longitudinal framing, the coaming shall be strengthened by longitudinals spaced not more than 900 mm apart.

In case of transverse framing, vertical stiffeners shall be fitted between stays at every frame.

The hopper side coamings shall be extended beyond the hopper ends by the brackets for a distance equal to 1,5 times the coaming height. Deck girders extending not less than three frame spaces from a bracket end shall be fitted under the brackets.

3.6.2.11.8 In floating cranes, the tub plating shall not be cut at the upper deck. No horizontal welds are permitted in the tub plating within the area extending for $0,2h$ up and down from the upper deck (where h is the distance between the bottom and the upper deck in way of the tub position).

3.6.2.11.9 Diaphragms shall be fitted inside the crane tub in line with the upper deck and platform.

3.6.2.11.10 For outer plating of specific structures 20 mm and more in thickness in way of the hopper steel of not lower than grade D shall be utilized.

3.6.3 Design load.

3.6.3.1 Design loads on the main hull structures shall be determined in compliance with Sections 1 and 2 at draughts d_1 and d_2 and the wave coefficient c_w under dredging conditions and during voyage. For dredging conditions, the wave coefficient c_w shall not be taken greater than:

$$c_w = (D + h_c - d_1). \quad (3.6.3.1)$$

3.6.3.2 The maximum value of the design load for vessel's extremities during voyages shall be obtained as required by 2.8.3 using the draught at the section $0,1L$ from the forward perpendicular. For the transom bulkhead angles $\alpha_x = 0$ and $\beta_x = 90^\circ$ are assumed.

3.6.3.3 The design bending moments and shear forces in vessels of dredging fleet having $L \geq 60$ m shall be determined for voyage and for dredging conditions.

For voyage the hopper space is considered to be filled with water up to the effective waterline (or empty if such case is possible), stores and outfit are taken as 100 %, all gear being stowed for sea.

For the case of dredging operations, the hopper space is considered to be filled with homogeneous spoil up to the upper overflow level (coaming), there are no stores on board, the draught is equal to d_1 , gear being stowed for sea.

Wave bending moments and shear forces shall be determined as required by 1.4.4.

3.6.3.4 Opening vessels.

3.6.3.4.1 In opening vessels, still water and wave bending moment is created both by vertical and horizontal forces. Bending moments are calculated first in vGu , coordinate system and then recalculated for the basic inertia axes x and y of each semi-hull (refer to Fig. 3.6.3.4.1). A fully loaded hopper space at the maximum draught of the vessel is taken as a design case. Bending of each semi-hull hopper is considered separately. Deck hinges and hydraulic cylinders are assumed to be supports located at the hopper ends.

Besides, the following cases are considered:

sailing in the work area with spoil in the hopper, dredging gear stowed for sea;

voyage with water in the hopper space or in the ballast condition (the hopper is empty, wherever

practicable). Stores and outfit are taken in full, all gear stowed for sea.

3.6.3.4.2 The type of supporting structures and the clearance between two semi-hulls in the fore and aft ends of the hopper space determine the conditions of horizontal moments calculation.

Where supporting structures fitted at the deck or bottom level forward or aft of the hopper space provide the absence of any clearance between the semi-hulls, and the length of the supporting structures creates adequate fixing against the horizontal forces acting athwart the hopper space, the horizontal force calculation is made assuming that a semi-hull is rigidly restrained at each hopper end.

Otherwise a semi-hull is considered to be freely supported.

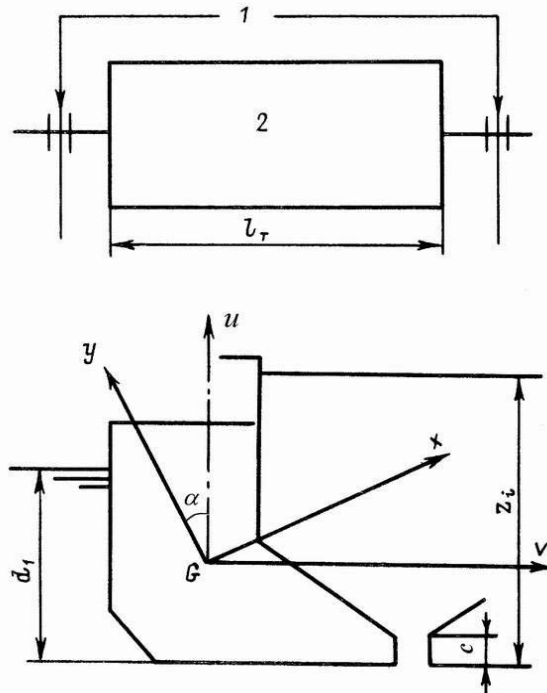

Fig. 3.6.3.4.1
1 – hinges; 2 – hopper space

3.6.3.4.3 Vertical loads.

The vertical bending moment at any section M_v , in kN · m, acting on each semi-hull shall be determined by the formula

$$M_v = 0,5(M_{sw} + M_w), \quad (3.6.3.4.3)$$

where: M_{sw} – still water bending moment to be obtained by load integration of the vessel with connected hulls for loading conditions referred to in 3.6.3.4.1, in kN · m;

M_w – wave bending moment for the vessel with connected hulls, to be determined as required by 1.4.4, in kN · m.

Vertical moments are considered positive in case of hogging and negative in case of sagging.

3.6.3.4.4 Horizontal loads.

The horizontal bending moment M_{hi} , κН·м, in kN/m, acting on each semi-hull at the sections taken in the middle and at ends of the hopper space shall be determined by the formula

$$M_{hi} = M_{swhi} + M_{whi}, \quad (3.6.3.4.4-1)$$

where: M_{swhi} , M_{whi} – horizontal still water and wave bending moments at the section under consideration, respectively, in kNm.

Horizontal moments are considered positive where the outer side of one semi-hull is subjected to tensile stresses.

The horizontal moment acting on a semi-hull depends on the fixing used at the ends of the hopper space.

Where a semi-hull is considered rigidly fixed at the ends of the hopper space, the horizontal moment shall be determined using the following formulae:

in still water:

at the section taken in the middle of the hopper space

$$M_{swh} = 0,10 p l_h^2 ; \quad (3.6.3.4.4-2)$$

at the hopper end sections

$$M'_{swh} = -0,10 p l_h^2 , \quad (3.6.3.4.4-3)$$

where: $p = 0,5g \left(\rho H_2^2 - \rho d_1^2 \right)$ (p – in kN/m);

in waves:

at the section taken in the middle of the hopper space

$$M_{wh} = M_w \frac{d_1}{B} \left(\psi_1 + \psi_2 \frac{E}{d_1} \right); \quad (3.6.3.4.4-4)$$

at the hopper end sections

$$M'_{wh} = -M_w \frac{d_1}{B} \left(\psi_3 + \psi_4 \frac{E}{d_1} \right); \quad (3.6.3.4.4-5)$$

$$\psi_1 = 0,61l_T/L - 0,103;$$

$$\psi_2 = 0,50l_T/L - 0,100;$$

$$\psi_3 = 0,85l_T/L - 0,112;$$

$$\psi_4 = 0,37l_T/L - 0,050;$$

$$E = \chi(C_b + 0,7) \left[1,38 - 0,128 \left(\frac{300-L}{100} \right)^{3/2} \right];$$

$$\chi = 1,35L / 100 - 0,215.$$

Where the semi-hull is not fixed at the hopper ends, the horizontal moment at the section at the middle of the hopper space shall be determined by the following formulae:

in still water

$$M_{swh} = 0,15p l_h^2; \quad (3.6.3.4.4-6)$$

in waves

$$M_{wh} = M_w \frac{d_1}{B} \left(1 + \psi_5 \frac{E}{d_1} \right), \quad (3.6.3.4.4-7)$$

where: $\psi_5 = 1,23(l_h / L - 0,5)$.

The still water and wave horizontal bending moments at the hopper end sections are equal to zero.

The sign of M_w shall be taken into account in determination of M_{wh} and M'_{wh} .

It is assumed that M_{swh} and M'_{swh} are equal to zero during voyage whatever the fixing conditions are.

3.6.3.5 Bending moments acting on the hull of the floating crane shall be determined for operating conditions in the work area and a voyage.

For the operation in the work area the design vertical bending moment M_{op} , in kN m, shall be determined by the formula:

$$M_{op} = M_{sw} + M_g + M_w, \quad (3.6.3.5)$$

where: M_{sw} – still water bending moment according to **1.4.3**, in kN·m;

M_g – bending moment due to the weight of the load suspended on the crane hook, in kN·m. for a voyage M_g is assumed to be equal to zero;

M_w – wave bending moment for work areas and a voyage to be determined using a procedure agreed with the Register for a specified length and height of the wave.

3.6.3.6 The design pressure p_s , in kPa, on the bulkheads bounding the hopper space, on the structures of the enclosed watertight centre line box keel shall be determined by the formula

$$p_s = \rho_s g z_i, \quad (3.6.3.6)$$

where: z_i – distance of the load application point from the upper weir level (upper edge of the coaming), in m.

3.6.3.7 The design load p_1 , in kPa, on a partial bulkhead (diaphragm) or a transverse ring structure of the side buoyancy space at a level of the mid-height of the hopper lower cross member due to spoil pressure, having regard to the outer counterpressure, shall be determined by the formula

$$p_1 = g (0,8\rho_{tp} H_1 - 1,5\rho_{tp} h_k - 0,1\rho H_1 \varepsilon), \quad (3.6.3.7)$$

where: $\varepsilon = 0$ when $D \leq 4$ m;

for $D > 4$ m:

$\varepsilon = 0,2 D - 0,8$ when $d_1/D \leq 0,75$;

$\varepsilon = 0,4 D - 1,6$ when $d_1/D > 0,75$.

3.6.3.8 The vertical design load p_2 , in kPa, due to spoil pressure, having regard to the counterpressure of the water on the lower cross member of the hopper space shall be determined by the formula

$$p_2 = g [\rho_s H_2 - (\rho d_1 + 0,5\rho c_w) - \rho_s (l_{l.cr} - b_{b,k}) A_{l.cr} / (b l_{l.cr}) - 1,5\rho_s A_{b,k} / l_{l.cr}] \quad (3.6.3.8)$$

3.6.3.9 The horizontal design load p_3 , in kPa, due to the dredged spoil pressure on face plates of the hopper lower cross member shall be determined by the formulae:

for the upper face plate

$$p'_3 = g \rho_s h_{l.cr} / 6$$

(3.6.3.9)

for the lower face plate

$$p''_3 = g \rho_s h_{l.cr} / 3$$

3.6.3.10 The design load p_4 , in kPa, on the framing members and on the plating of the hopper coaming shall be determined by the formula

$$p_4 = g \rho_s h_c. \quad (3.6.3.10)$$

The value p_4 shall be taken not less than 15 kPa.

3.6.3.11 The design axial force N , in kN, acting at the mid-height level of the hopper lower cross member on a diaphragm or a transverse ring structure of the side buoyancy space shall be determined by the formula

$$N = g b H_1 [0,4\rho_s H_1 + 0,63\rho_s h_c - 0,03\rho H_1 m], \quad (3.6.3.11)$$

where: $m = 0$ for $D \leq 3,5$ m;

$m = 1$ for $D > 3,5$ m, $d_1/D \leq 0,75$;

$m = (9D - 31,5)(d_1/D - 0,75)$ for $D > 3,5$ m, $d_1/D > 0,75$.

3.6.3.12 The design axial force $R_{l.cr}$, in kN, acting on the lower cross member of the hopper space shall be determined by the formula

$$R_{l.cr} = 0,163 g \frac{b}{H_1} [\rho_s H_2^2 (3D - H_2) - \rho (d_1 - 0,5c_w)^2 (3D - d_1 + 0,5c_w)]. \quad (3.6.3.12)$$

3.6.3.13 The design axial force $R_{up.cr}$, in kN, acting on the upper cross members of the hopper space shall

be determined by the following formulae:

.1 for the upper cross member fitted at the deck level

$$R_{up.cr} = R_1 - R_2 - R_3 - R_4, \quad (3.6.3.13.1)$$

where: R_1 – pressure of dredged spoil on the upper cross member determined as:

$$R_1 = g\rho_s \frac{0,082bH_2^2}{H_1} (2H_2 - 3h_{l.cr});$$

R_2 – external hydrostatic pressure on the upper cross member determined as:

$$R_2 = g\rho \frac{0,082b(d_1 - 0,5c_w)^2}{H_1} (2d_1 - c_w - 3h_{l.cr});$$

R_3 – reaction due to supporting bending moment at the junction of the diaphragm with the lower cross member determined as

$$R_3 = p_2 \frac{bl_{l.cr}^2}{12H_1};$$

R_4 – force resulting from supporting reactions of the hopper lower cross member determined by the formula

$$R_4 = \frac{b l_{l.cr}}{4} \frac{b_2}{H_1} \left(p_2 + \frac{0,5 g\rho_s A_{k.b}}{l_{l.cr}} \right);$$

.2 for the upper cross member fitted at the upper face plate of the hopper coaming

$$R_{up.cr} = g\rho_s b h_c^2. \quad (3.6.3.13.2)$$

3.6.3.14 The design load on deck shall be not less than 20 kPa.

3.6.3.15 The design loads on the structures of each semi-hull of opening vessels shall be determined in compliance with **3.6.3.1** ÷ **3.6.3.14**.

3.6.3.16 In opening hopper dredgers and hopper barges, for each hydraulic press, the horizontal statical force F_H , in kN, necessary to keep the hull closed is determined by the formula (refer also to Fig. 3.6.3.16):

$$F_H = (1/n_1 a_3)[-F_h a_1 + F_d a_2 + 0,5(g\Delta b_1 - g\Delta_n b_2 - gQ_s b_3)], \quad (3.6.3.16-1)$$

where: n_1 – number of hydraulic presses;

F_h – horizontal force of water pressure on the hull, determined by the formula

$$F_h = 0,5\rho g l_h (d_1 - 0,5c)^2;$$

F_d – horizontal force of dredged spoil pressure on the hull, determined by the formula

$$F_d = 0,5\rho_s g l_h (H_2 - 0,5c)^2;$$

where: for c – refer to Fig.3.6.3.4.1;

$a_1, a_2, a_3, b_1, b_2, b_3$ – force arms, in m (refer to Fig. 3.6.3.16).

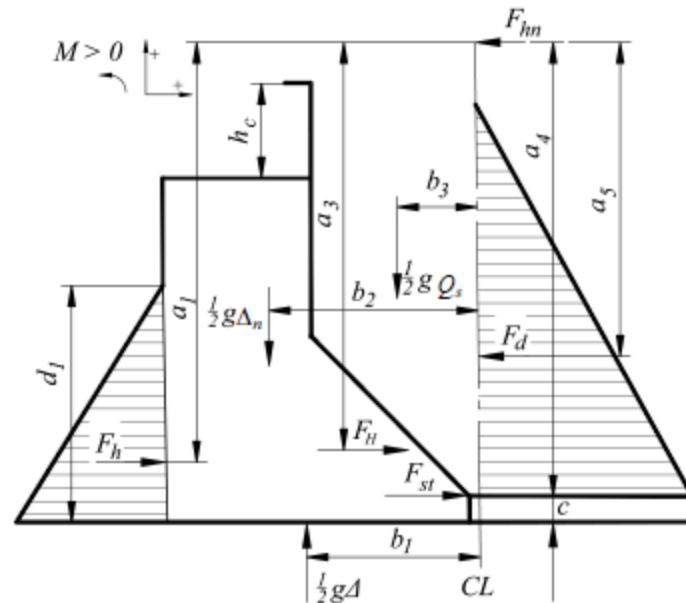

Fig. 3.6.3.16

For design force F_{des} , the maximum pressure value achieved by the hydraulic press is adopted, with $F_{des} \geq F_H$.

The horizontal static force in each hinge F_{hm} , in kN, is determined by the formula

$$F_{hm} = 0,5[F_h + n_1 F_H - F_d - n_1 a_3 (F_{des} - F_h) / a_4], \quad (3.6.3.16-2)$$

where: a_4 – arm of the force acting upon the stop, in m.

The horizontal static force acting upon each stop is determined by the formula

$$F_{st} = n_1 a_3 (F_{des} - F_h) / (n_2 a_4), \quad (3.6.3.16-3)$$

where: n_2 – number of stops.

The vertical components of static forces in hinges are assumed equal to zero.

3.6.3.17 The dynamic forces acting on hydraulic cylinders and deck hinges shall be determined by calculations of vessel's motions in a seaway, with various course angles, in light-ship and full-load conditions. Based on these calculations, maximum vertical and horizontal forces acting on the hydraulic presses are determined. The calculation shall be made using a procedure approved by the Register.

3.6.4 Scantlings of structural members.

3.6.4.1 Scantlings of structural members shall be determined in compliance with Sections 1 and 2, having regard to the provisions of this Chapter.

3.6.4.2 The required hull section modulus of a singlehull vessel of 60 m in length and over shall be determined as required by 1.4.6 for deck, bottom, upper edge of the hopper coaming, having regard to specified work areas and voyages. The greater value obtained for the work area or voyage (refer to 3.6.3.3 and 3.6.3.4) shall be taken.

For opening hopper dredgers and hopper barges the required section modulus shall be determined for the case when both semi-hulls are connected (refer to 3.6.3.4).

3.6.4.3 When calculating the actual section modulus of the hull in way of the hopper space as required by 1.4.8, account shall be taken of all continuous longitudinals, longitudinal bulkheads and the hopper space coamings with longitudinals, 85 % of the total area of centre line box keel longitudinal members, provided they are properly interconnected with the longitudinal framing members beyond the hopper and fitting of transverse members regulated by the Rules, inside the hopper.

The continuous deck plating longitudinally framed above the hopper space and a wash bulkhead in the hopper may be included in the actual section modulus calculation using a procedure approved by the Register.

3.6.4.4 Longitudinal strength of each semi-hull of opening hopper dredgers and hopper barges shall be checked for vertical and longitudinal bending moments in asymmetrical bending (refer to Fig. 3.6.3.4.1).

3.6.4.4.1 Normal stresses arising in cross-section points under conditions of asymmetrical bending shall

be determined amidships and at the end bulkhead sections of the hopper space (from inside the hopper), provided the hulls at this position are rigidly restrained.

Stresses σ , in MPa, shall be determined by the formula:

$$\sigma = \left(M_x \frac{y}{I_x} - M_y \frac{x}{I_y} \right) \cdot 10^{-3}, \quad (3.6.4.4.1-1)$$

where: $M_x = M_v \cos \alpha - M_h \sin \alpha$;

$M_y = M_v \sin \alpha + M_h \cos \alpha$;

For M_v, M_h – refer to **3.6.3.4.3** and **3.6.3.4.4**;

α – rotation angle of main inertia axis (positive value of α – rotation Gu axis counter-clockwise), it shall be determined by the formula

$$\operatorname{tg} 2\alpha = 2I_{uv}/(I_u - I_v); \quad (3.6.4.4.1-2)$$

$$I_{uv} = \sum_i u_i v_i d S_i - \text{centrifugal inertia moment about axes } Gu, Gv \text{ with no regard for wear allowance, in m}^4;$$

u_i, v_i – distance of the centre of gravity of i -th member area from the axes Gu, Gv , in m;

dS_i – i -th member area, in m^2 ;

I_u, I_v – inertia moments of the semi-hull cross-section about axes Gu, Gv with no regard for wear allowance, in m^4 ;

x, y – coordinates of the section point under consideration about main axes Gx, Gy (refer to Fig. 3.6.3.4.1), in m;

I_x, I_y – inertia moments of the semi-hull cross-section about the main axes with no regard for wear allowance, in m^4 .

3.6.4.4.2 Normal stresses acting in the semi-hull cross-section (for normal strength structural steel) shall not exceed:

150 MPa for the lower edge of the deck stringer;

145 MPa for the upper edge of the plate keel;

165 MPa in the face plate of the hopper coaming.

3.6.4.4.3 Permissible shear stresses for members made of normal strength structural steel and participating in the longitudinal bending are assumed equal to 115 MPa. Equivalent stresses $\sigma_{\text{eq}} = \sqrt{\sigma^2 + 3\tau^2}$ at the sections where substantial normal stresses σ and shear stresses τ (at the hopper ends) act shall be not more than 170 MPa.

3.6.4.4.4 Buckling strength of compressed members according to **1.6.5** shall be ensured.

3.6.4.5 Bottom framing.

3.6.4.5.1 When the bottom is transversely framed, the moment of inertia and scantlings of floors in side buoyancy spaces shall be determined as required by **2.3.4.1.1**; in this case, to be taken as B_1 is doubled breadth of the buoyancy space over the bottom.

3.6.4.5.2 Where a single bottom is longitudinally framed, the section modulus of bottom longitudinals in buoyancy spaces shall be not less than that determined in compliance with **2.3.4.2.1**. The floors shall be fitted in line with transverse ring structures, their section modulus and cross sectional area shall be not less than determined from **2.3.4.2.3** and **2.3.4.2.4**. The section modulus and depth of a side girder shall be not less than those required for the floor. The floor web depth shall not be less than $0,13B_1$ (refer to **3.6.4.5.1**).

3.6.4.5.3 The scantlings of the bottom framing members in each semi-hull of opening vessels shall be determined as required by **2.3.4.2**; to be taken as breadth B_1 is the breadth of one semi-hull at the section under consideration. There is no bottom centre girder in opening vessels.

3.6.4.5.4 The scantlings of double bottom members in way of the hopper space are determined as for dry cargo ships having double skin construction according to **2.4** with regard to **3.6.2.4**; beyond the hopper as for dry cargo ships with single skin construction in compliance with the requirements of the same paragraphs.

The plate floor spacing shall not exceed the maximum spacing of transverse ring structures, specified in **3.6.2.11.1**.

3.6.4.5.5 For floating cranes the section modulus of bottom transverses shall be as required by **2.3**, and additional bottom longitudinals shall have the same section modulus as for main longitudinals.

3.6.4.5.6 In calculating the section modulus and the depth of floors in accordance with **2.3**, B_1 is assumed to be the floor span between the side shell and the longitudinal bulkhead or between the longitudinal bulkheads, but not less than $0,4$ of the full breadth of the ship.

3.6.4.5.7 In case of longitudinally framed bottom, the scantlings of floors and bottom longitudinals of floating cranes beyond the double bottom area shall be determined in accordance with **2.3.4.2**.

3.6.4.6 Shell plating.

3.6.4.6.1 Shell plate scantlings are determined in accordance with **2.2.4**. The thickness of the bottom strakes to which hopper longitudinal bulkheads or well sides are connected shall be increased by 15 per cent as against that of the bottom plating. Where there is no centre line box keel, the thickness of the bottom strakes abutting on the hopper longitudinal bulkhead shall be increased by 50%.

3.6.4.6.2 The side shell plating thickness at the hopper ends shall not be less than required by **1.4.7**.

3.6.4.6.3 In vessels with pontoon hulls, the thickness of the bottom and side shell plating within $0,15L$ from the forward and after perpendiculars shall not be less than the plating thickness within the midship region.

3.6.4.6.4 The thickness of the well side plating shall be equal to the thickness of the side shell plating in area concerned, but not less than 8 mm.

3.6.4.6.5 In opening vessels the shell plating thickness shall be determined with regard for **3.6.4.4**.

The thickness of the bottom strakes at the hopper longitudinal bulkhead need not be increased.

3.6.4.6.6 In floating cranes the thickness of the bottom plating within $0,2L$ from the forward perpendicular shall be increased over the entire breadth of the hull by 30 % as against the minimum thickness required by **2.2.4.8**.

In the fore peak and the areas extending forward for $0,1L$ from the stern transom corners and inboard for $0,1B$, the thickness of the side shell plating shall be increased over the entire depth by 30 % as compared to the minimum thickness required by **2.2.4.8** (refer also to **3.6.2.5.2**).

In other regions along the hull length, the minimum thickness of the shell plating shall be increased by 10 % as against that prescribed by **2.2.4.8**.

3.6.4.6.7 The plating thickness of the bow and stern transoms in floating cranes shall not be less than required by **3.6.4.6.3**.

3.6.4.7 Side framing.

The scantlings of the side framing members shall be determined in compliance with 2.5, having regard to **3.6.2.5**, **3.6.2.11** and the requirements given below:

.1 the section modulus of frames in transversely framed side buoyancy spaces shall be determined from **2.5.4.1** as for dry cargo ships.

Where a side stringer is fitted at a level of fenders, main frame span may be determined in compliance with **2.5.1.2** as for side transverses of tankers, provided the structure of the side stringer meets the requirements of **3.6.4.7.2**. Where no transverse ring structures are fitted, braces may be provided in line with horizontal girders of longitudinal bulkheads;

.2 the scantlings of side stringers shall be determined as required by **2.5.4.4** as for the case of fitting web frames. The width of the side stringer shall not be less than $0,08l$ (l = stringer span as measured between web frames or between those and tight transverse bulkheads) or 2,5 times the frame depth, whichever is the greater. Side stringers shall be aligned with cross ties of the transverse ring structures;

.3 the section modulus of side longitudinals shall be determined as required by **2.5.4.3** with k_{σ} values taken as for dry cargo ships;

.4 the section modulus and cross-sectional area of web frames which are a part of a transverse ring structure shall be not less than those required in **2.5.4.5** for side transverses of tankers.

A web frame span shall be measured between the inner edges of the floor and an inner edge of the beam.

The depth of the web frame shall not be less than $0,1l$ or 2,5 times the width of longitudinals (whichever is the greater) and may be assumed varying with reduction at the upper end and increase at the lower end by 10 % as against the average value;

.5 the section modulus of well longitudinal bulkhead stiffeners shall not be less than required for side frames;

.6 in floating cranes, the section modulus of main and intermediate frames in the fore peak shall be increased by 20 % as compared to that required by **2.8.4.2.2**;

.7 the section modulus of web frames in floating cranes W , in cm^3 , within the region specified in **3.6.2.5.3** shall not be less than

$$W = 0,95 \left(300 + \frac{120}{\sigma_n} b_p l^2 \right) \omega_c \quad (3.6.4.7.7)$$

where: l – web frame span measured between the deck and the upper edge of the floor, in m;
 p – as defined in **3.6.3**, but not less than $0,5\rho g l$, in kPa;

.8 the scantlings of the framing members of the bow and stern transoms shall not be less than required by 3.6.4.7.2 – 3.6.4.7.4 and 3.6.4.7.6.

3.6.4.8 Decks.

3.6.4.8.1 The plating thickness of the strength deck within the midship region shall be taken not less than the sheerstrake thickness. The minimum thickness of the deck plating in vessels of dredging fleet shall be determined according to 2.6.4.2 as for the strength deck. For floating cranes the minimum thickness of the upper deck shall be increased by 10 % as against that prescribed by 2.6.4.2 as for the strength deck.

3.6.4.8.2 Compressive stresses in deck shall be determined under the action of bending moment components according to 3.6.3. The buckling strength requirements of 1.6.5 shall be met.

3.6.4.8.3 The depth of deck transverses in buoyancy spaces which form a part of the transverse ring structure shall be equal to two-thirds of the floor depth, while the thickness of the web plate and sizes of the face plate shall be equal to those of the vertical webs. The depth of the deck transverse shall be not less than 2,5 times the height of the deck longitudinal.

3.6.4.8.4 For floating cranes the section modulus of deck girders shall be determined as required by 1.6.4.1 with $k_\sigma = 0,6$ and $m = 12$.

3.6.4.8.5 The deck plating thickness under the seats of special arrangements fitted on the deck (cat cranes of suction tubes, transfer appliances, grab cranes, etc.) and where special metal structures pass through the deck (main and ladder galleys) shall be increased by 25%.

3.6.4.9 The scantlings of side and deck framing members, the thicknesses of deck plating, bulkhead framing and plating, and coamings of opening vessels shall be determined with regard for 3.6.4.4.

Where vertical webs and web frames are connected by cross ties or braces, the scantlings of vertical webs, web frames and braces shall be determined by calculation.

3.6.4.10 In vessels with pontoon hulls, the scantlings of side stringers at the forward end of the vessel shall be prescribed as required by 2.8.4.5, the height and thickness of vertical webs and web frames shall be the same as the width and thickness of the stringer.

3.6.4.11 Specific structures of vessels of dredging fleet.

3.6.4.11.1 The section modulus W , in cm^3 , of the diaphragm of the buoyancy space after deduction of openings, or the total section modulus of a vertical web and a web frame of the transverse ring structure at the section of a mid-point of the hopper lower cross member depth shall not be less than

$$W = \frac{p_1 b H_1^2 \cdot 10^3}{m k_\sigma \sigma_n} \omega_k, \quad (3.6.4.11.1)$$

where: for H_1 – refer to Fig. 3.6.1.6;

$m = 12$;

$k_\sigma = 0,6$;

p_1 – as defined in 3.6.3.7.

3.6.4.11.2 The cross-sectional area f , in cm^2 , of the diaphragm, or the total sectional area of a vertical web and a web frame of the transverse ring structure at a level of a mid-point of the hopper lower cross member depth shall be not less than

$$f = \frac{10N}{k_\tau \tau_n} + 0,1 \Delta f_i, \quad (3.6.4.11.2)$$

where: N – as defined in 3.6.3.11;

$k_\tau = 0,65$;

$\Delta f_i = \Delta s b_i$;

b_i – typical member scantlings (half-breadth of deck, web height of longitudinal, etc.), in cm.

The scantlings of the transverse ring structure members (bottom transverse, vertical web, side and deck transverses) shall be not less than required by the relevant paragraphs of this Chapter for such members.

3.6.4.11.3 The section modulus W , in cm^3 , sectional area of the hopper lower cross member web f_w , in cm^2 , after deducting openings, sectional area of the floor with face plates f_0 , in cm^2 , shall not be less than::

$$W = \frac{10^3 b l_{l.cr}^2}{m k_{\sigma} \sigma_n} p_2 \omega_c; \quad (3.6.4.11.3-1)$$

$$f_w = 5 \frac{b l_{l.cr}}{k_{\tau} \tau_n} (p_2 + \frac{0,5 p_s g}{l_{l.cr}} A_{b.k}) + 0,1 \Delta f_i; \quad (3.6.4.11.3-2)$$

$$f_0 = \frac{10 R_{l.cr}}{k_{\sigma_p} \sigma_n} + 0,1 \Delta f_i, \quad (3.6.4.11.3-3)$$

where: $m = 12$;

$$k_{\sigma} = 0,45;$$

$$k_{\sigma_p} = 0,2;$$

$$k_{\tau} = 0,45;$$

p_2 – as defined in **3.6.3.8**;

$R_{l.cr}$ – as defined in **3.6.3.12**;

for Δf_i – refer to **3.6.4.11.2**.

3.6.4.11.4 The section modulus of the face plates of the hopper lower cross members W , in cm^3 , about the horizontal axis and sectional area $f_{f,p}$, in cm^2 , shall not be less than:

for the upper face plate

$$W = \frac{10^3 h_{l.cr} l_1^2}{m k_{\sigma} \sigma_n} [3 - \frac{(l_1 - l_2)^2}{l_1^2}] p_3' \omega_c \quad (3.6.4.11.4-1)$$

$$f_n = \frac{2,5 p_3' h_{l.cr} (l_1 + l_2)}{k_{\tau} \tau_n} + 0,1 \Delta f_i; \quad (3.6.4.11.4-2)$$

for the lower face plate

$$W = \frac{2 p_3'' h_{l.cr} l_2^2 \cdot 10^3}{m k_{\sigma} \sigma_n} \omega_c; \quad (3.6.4.11.4-3)$$

$$f_{f,p} = \frac{5 p_3'' h_{l.cr} l_2}{k_{\tau} \tau_n} + 0,1 \Delta f_i, \quad (3.6.4.11.4-4)$$

where: for l_1, l_2 – refer to **3.6.1.6**;

$$m = 24;$$

$$m_1 = 12;$$

$$k_{\sigma} = 0,6;$$

$$k_{\tau} = 0,45;$$

p_3', p_3'' – as defined in **3.6.3.9**;

Δf_i – as defined in **3.6.4.11.2**.

3.6.4.11.5 The section modulus of bulkhead vertical webs, horizontal girders, vertical stiffeners and longitudinals of the hopper longitudinal bulkheads shall be determined as for side framing according to 3.6.4.7 with substitution of p according to **2.5.3** by p_s according to **3.6.3.6**. For the longitudinal bulkhead stiffeners $m=11$ and $k_{\sigma}=0,75$.

The depth of the vertical web shall be not less than $0,12l$ and may be assumed varying with reduction at the upper end and increase at the lower end by 10 % as compared to the average value.

Two upper longitudinals shall be taken the same as the third longitudinal from the deck.

Besides, three upper and three lower longitudinals shall be checked according to **1.6.5.4**.

The width of the horizontal girder shall be equal to that of the bulkhead vertical web.

3.6.4.11.6 The plating thickness of the hopper longitudinal and end bulkheads shall be determined as required by 1.6.4.4 assuming $p=p_s$ (where p_s shall be obtained from **3.6.3.6**), $k_{\sigma}=0,7$, $m=15,8$.

The upper strake thickness of the hopper longitudinal bulkhead at $0,1D$ below the deck shall not be less than the sheerstrake thickness. The lower strake thickness of the longitudinal bulkhead at $0,1D$ from the base

line shall not be less than the bottom plating thickness.

3.6.4.11.7 The minimum thickness of hopper bulkhead plating shall be equal to 8 mm for vessels having the length $L < 60$ m and 10 mm for vessels having the length $L \geq 80$ m. For intermediate values of L , the minimum thickness shall be determined by linear interpolation.

3.6.4.11.8 The section modulus W , in cm^3 , of vertical stiffeners and stanchions of the hopper coaming shall not be less than determined by the formula¹:

$$W = \frac{p_4 a h_c^2 \cdot 10^3}{m k_\sigma \sigma_n} \omega_c, \quad (3.6.4.11.8-1)$$

where: p_4 – as defined in **3.6.3.10**;

$m = 15$ – for stanchions where upper cross members are fitted in line with transverse ring structures at the coaming top;

$m = 6$ – for stanchions where no upper cross members are fitted at the coaming top;

$m = 15,6$ – for vertical stiffeners where transverse framing is adopted;

$k_\sigma = 0,6$.

The section modulus W , in cm^3 , of horizontal stiffeners and face plate of the coaming shall not be less than

$$W = \frac{p_4 a b^2 z_i \cdot 10^3}{m k_\sigma \sigma_n h_c} \omega_c, \quad (3.6.4.11.8-2)$$

where: z_i – distance between the coaming top and horizontal stiffeners, but not less than half the coaming height, in m;

$m = 12$;

$k_\sigma = 0,2$.

The sectional area f_{st} of the coaming stanchion, in cm^2 , at deck shall not be less than

$$f_{cr} = \frac{4 p_4 a h_c}{k_\tau \tau_n} + 0,1 \Delta f_i, \quad (3.6.4.11.8-3)$$

where: $k_\tau = 0,45$;

Δf_i – as defined in **3.6.4.11.2**.

The plate thickness of the side (end) coaming shall be determined as for the longitudinal (end) bulkhead of the hopper p_s according to **3.6.3.6** as measured at the deck level, but it shall be taken not less than the upper strake thickness of the longitudinal bulkhead.

The depth of the stanchion at deck shall be not less than $0,12 h_c$ and the thickness not less than the coaming thickness.

The plate thickness of the coaming and moment of inertia of the horizontal stiffeners and face plate of the coaming shall meet the buckling strength requirements according to **1.6.5**.

3.6.4.11.9 The sectional area of the upper cross members spanning hopper space at deck level and/or coaming level $f_{up.cr}$, in cm^2 , shall not be less than

$$f_{up.cr} = 0,085 R_{up.cr} + 0,1 \Delta f_i, \quad (3.6.4.11.9-1)$$

where: Δf_i – as defined in **3.6.4.11.2**.

Where a load from bottom closing appliances is applied to the upper cross members, their strength shall be checked using the equivalent stress given below

$$\sigma_{eq} = \sqrt{\sigma_{max}^2 + 3\tau_{sh}^2} \leq 0,75\sigma_n, \quad (3.6.4.11.9-2)$$

where:

$$\sigma_{max} = \frac{10R_{up.cr}}{f_{up.cr}} + \frac{M_b}{W} \cdot 10^3 ;$$

$$\tau_{sh} = 10N_{sh}/f_w;$$

M_b, N_{sh} – maximum bending moment, in kNm, and shear force, in kN, due to transverse load;

W – actual section modulus of the upper cross member, in cm^3 ;

$f_{up.cr}, f_w$ – full sectional area of the upper cross member and sectional area of the cross member web, in cm^2 .

3.6.4.11.10 Where no upper cross members are fitted at a deck level in line with transverse ring structures, a part of the coaming structure with the upper portion of the side buoyancy space located at 0,1D below the deck line (refer to Fig. 3.6.4.11.10) shall have a section modulus W , in cm^3 , about a horizontal axis not less than

$$W = \frac{550R_{up.cr}(l_h - b)^2}{b\sigma_n} \omega_c \quad (3.6.4.11.10-1)$$

The thickness of the deck plating s , in mm, shall not be less than

$$s = \frac{1,11R_{up.cr}(l_h - b)}{bB_3\tau_n} + \Delta s, \quad (3.6.4.11.10-2)$$

where: for B_3 – refer to Fig. 3.6.4.11.10.

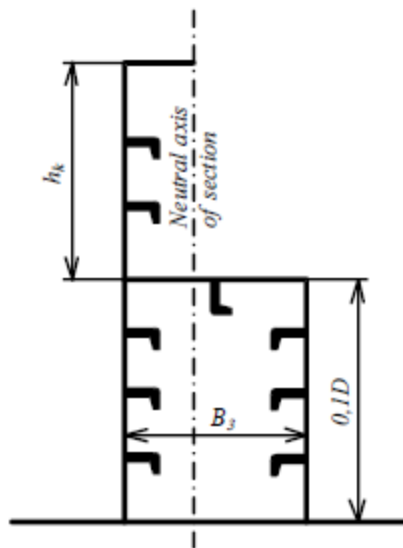

Fig. 3.6.4.11.10

3.6.4.11.11 The scantlings of hull structural items in places where hinges and hydraulic presses of opening vessels are installed shall be determined by direct calculation of the effect of static and dynamic forces in accordance with 3.6.3.16.

3.6.4.11.12 The strength calculation of foundations and attachments of hydraulic presses shall be made as regards the effect of forces determined according to 3.6.4.11.11.

3.6.4.12 Specific structures of floating cranes.

3.6.4.12.1 The thickness of the tub plating at the upper deck shall be determined by calculation based on the total bending moment due to load and weight of the moveable upper structure of the crane applied to the supporting tower, and the horizontal component of the load for the case when a design safe working load of the crane with the lifting height from the water level at the maximum outreach is used.

Permissible stresses for normal strength steel shall not be more than:

$$\sigma = 140 \text{ MPa and } \tau = 80 \text{ MPa.}$$

The buckling strength of the tub plating over its entire height shall be ensured to the value

$$\sigma_{cr} = 2,5R_{eH}.$$

3.6.4.12.2 The inertia moment I_{\min} , in cm^4 , of the tub vertical stiffeners (if any) shall not be less than

$$I_{\min} = (1,03l - 1,80y) s^3, \quad (3.6.4.12.2)$$

where l = stiffener span measured between the bottom and the platform or between the platform and the deck, whichever is the greater, in m. Where the platform is omitted, the distance between the bottom and the deck is measured;

y = spacing of stiffeners, measured along the chord line, in m;

s = tub plating thickness at the stiffener mid-span, in mm.

3.6.4.12.3 The plating thickness of the bulkheads forming a cross and the bearing contour shall not be less than determined according to 2.7.4.1, assuming

$$k_{\sigma} = 0,70;$$

$\Delta s \geq 4 \text{ mm}$ for bulkheads forming the cross and

$\Delta s \geq 2 \text{ mm}$ for those forming the bearing contour.

For cranes having a safe working load more than 100 t, the stressed condition of framing members and plating of bulkheads forming the cross under the loads transferred from the fixed supporting tower in case of using the design safe working load at the maximum outreach shall be checked according to the procedure approved by the Register.

3.6.4.12.4 The plating thickness of the upper deck and the bottom s' , in mm, in way of the crane tub shall not be less than

$$s' = \alpha s, \quad (3.6.4.12.4)$$

where: s – as defined in 3.6.4.12.1;

$\alpha = 0,6$ and $0,4$ for the upper deck plating and bottom plating, respectively.

The dimensions of the plates of increased thickness shall be taken in accordance with Fig. 3.6.4.12.4.

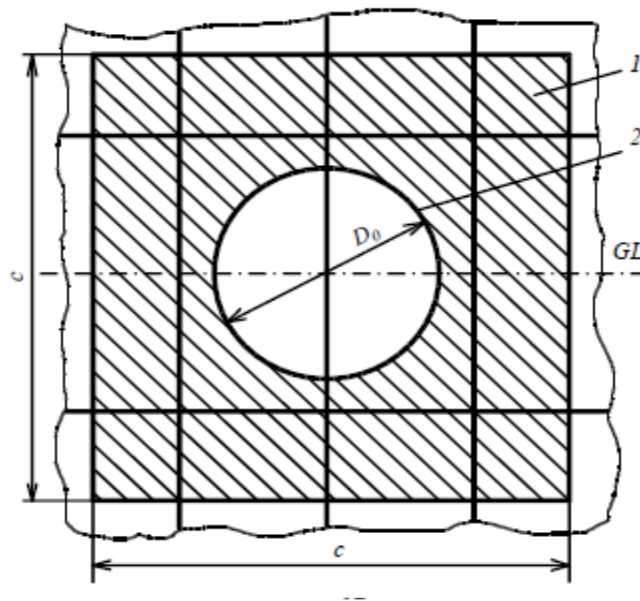

Fig. 3.6.4.12.4

1 - thickened plate; 2 - tub

3.6.5 Special requirements.

3.6.5.1 Where vessels are intended to ground during the course of normal service, the bottom of such vessels shall be suitably strengthened, as follows:

.1 the thickness of the bottom shell plating shall be increased by 20 % over the minimum requirement;

.2 where the double bottom is omitted and transverse framing system is adopted, the bottom shell plating between the bottom side girders shall be strengthened by horizontal stiffeners.

In line with horizontal stiffeners vertical stiffeners shall be fitted. The horizontal stiffeners shall pass through openings in the floors and be welded to them;

.3 where double bottom is omitted and longitudinal framing system is adopted, the bottom shell plating shall be strengthened by additional floors, the depth of which shall be not less than 2,5 times the depth of the bottom longitudinal and a thickness equal to that of the main floors. The main floors shall be strengthened by vertical stiffeners fitted in line with bottom longitudinals. Side girders shall not be spaced more than 2,2 m apart. The scantlings of bilge longitudinals shall not be less than those required for the bottom;

.4 in transversely framed double bottom plate floors shall be fitted at every frame, side girders shall be spaced not more than 2,5 m apart, they shall be also fitted inboard or from longitudinal bulkheads at a distance not exceeding 2,5 m. The bottom shell plating shall be strengthened by horizontal stiffeners fitted between the side girders. Vertical stiffeners shall be fitted in line with horizontal stiffeners at every floor and be welded to them.

In longitudinally framed double bottom floors shall be fitted at every second frame, and side girders shall be spaced 2,5 m apart;

.5 in way of a recess for vertical girders of suction tubes, the following hull strengthening shall be provided:

side framing shall be reinforced by at least three web frames, the scantlings of which shall be the same as those required for the engine room, and by not less than three intercostal side stringers extending for three spacings from the extreme web frames which shall be fitted not less than 50 mm from the edge of the recess;

side shell plating in way of the recess shall be made of a curved welded-in plate, the vertical butt joint of this plate shall be not less than 100 mm from the edge of the recess;

the thickness of the deck stringer in way of the recess shall be increased by 60 % over the length equal to one spacing forward and abaft of web frames.

3.6.5.2 The requirements of **3.6.5.1** shall not apply to floating cranes for which deep sea service is specified and which are not likely to ground under any conditions of heel and trim.

3.6.5.3 The thickness of structural members which are subjected to abrasive wear due to the effect of spoil/water mixture (in particular, in case of special dredging methods used) shall be increased.

3.6.5.4 Dredging pumps shall be located in special spaces bounded by watertight bulkheads.

3.6.5.5 The scantlings of deck framing members on deck portions where heavy dredging (cargo handling) gear is installed, as well as where large heavy cargoes may be carried on decks of floating cranes or hopper dredgers shall be determined by calculation for the following conditions:

beams are considered to be rigidly fixed to the supporting structure;

a load (concentrated, partially distributed, etc.) shall be taken into account;

equivalent stresses for items made of normal strength steel σ_{eq} , in MPa, shall comply with the

$$\sigma_{eq} = \sqrt{\sigma^2 + 3\tau^2} \leq 170, \quad (3.6.5.5)$$

where: σ , τ – normal and shear design stresses at the section under consideration.

3.7 FISHING VESSELS AND SPECIAL PURPOSE SHIPS USED FOR PROCESSING OF SEA LIVING RESOURCES

3.7.1 General and symbols.

3.7.1.1 The requirements of this Chapter apply to fishing vessels having a stern trawling arrangement or a side trawling arrangement and to special purpose ship intended for processing, storage and/or transportation of catch.

3.7.1.2 The requirements for hull structures not referred to in this Chapter are given in Sections 1 and 2.

In no case shall the requirements for hull structures be less stringent than those contained in Sections 1 and 2.

3.7.1.3 For the purpose of this Chapter, the following symbols have been adopted:

b – breadth of stern ramp, in m;

G_1 – greatest specified mass of catch which can be handled by a special wheeled device or another

transport means, in t;

G_2 – mass of moving part of special wheeled device or another transport means, in t;

G – mass of processing equipment, in t;

S_d – factory deck area, in m^2 ;

h – spacing of boundaries of region of side strengthening from summer load line and ballast waterline;

A1–A7, E1–E6 – regions of strengthenings;

a – spacing of framing members under consideration, in m (refer to 2.1.2);

l – span of member under consideration (refer to 1.6.3.1);

Δs – corrosion and wear allowance added to plate thickness, in mm (refer to 1.1.5.1);

ω_k – factor taking account of corrosion allowance to the section modulus of the to framing member (refer to 1.1.5.3).

3.7.1.4 The regions of side strengthening of vessels mooring at sea are to be as required by 3.7.1.4-1 (for fishing vessels) and 3.7.1.4-2 (for special purpose ships) taking account notices from Tables 3.7.1.4-1 - 3.7.1.5-2. Spacing of boundaries of region of side strengthening up from summer loadline and down from ballast waterline depending on sea state at which ship would be moored is not to be less than determined in Table 3.7.1.4-3.

For special purpose ships, one or more fender areas shall be additionally established the boundaries of which are formed by sections lying within $0,05L$, forward and aft of the forward and aft edges accordingly of a group of floating fenders providing one mooring place for all specified variants of mooring. The boundaries of fender areas shall be determined at extreme positions of fenders and for all specified variants of mooring.

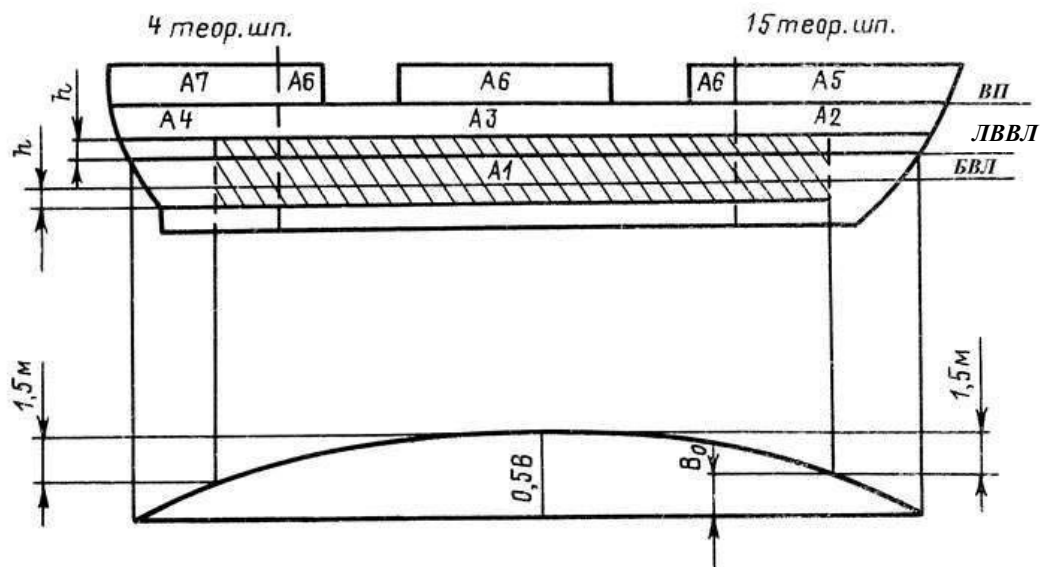

Fig. 3.7.1.4-1. Regions of strengthening of fishing vessels

E5	the same as for E3 region	between the upper edge of E3 region and the first tier superstructure deck
E6	the same as for E4 region	between the upper edge of E4 region and the first tier superstructure deck
¹ The boundaries of each berthing region are the forward edge of the bow and the aft edge of the aft floating fenders. The boundaries of the regions must be determined at the extreme positions of the fenders for any given mooring options.		

Table 3.7.1.4-3

Sea force No	<i>h</i> , in m
4	0,8
5	1,2
6	2,0

3.7.1.5 Fishing vessels designed for systematic fishing in ice conditions.

3.7.1.5.1 Fishing vessels intended for systematic operation in ice conditions shall have an ice class not lower than **Ice3** in accordance with the requirements of **3.10**.

3.7.1.5.2 Fishing vessels intended for systematic operation in ice conditions, which have the ice class **Ice3**, shall comply with the requirements of **3.10**, as well as with additional requirements contained in **3.7.1.6.4**, **3.7.2.10**, **3.7.3.4** and **3.7.4.5**.

3.7.1.5.3 No additional requirements are put forward with regard to the fishing vessels of ice class **Ice4** and above.

3.7.1.5.4 If the loadline entrance of a fishing vessel of ice class **Ice3** exceeds $0,25L$, an intermediate region of ice strengthening may be established, the boundaries of which shall be determined as in the case of **Ice4** ice class.

3.7.2 Construction.**3.7.2.1 Stern ramp construction.**

3.7.2.1.1 The after end structure of vessels having a stern ramp and/or stern trawling arrangements shall be strengthened by fitting additional longitudinal and transverse members (girders, transverses, cross ties, bulkheads and partial bulkheads).

The stern ramp shall be so constructed as to avoid flat of bottom in way of stern counter.

The connection of stern ramp sides to transom plating and of the ramp deck to bottom plating shall have a radius of rounding not less than 200 mm.

This connection may be made by using a bar not less than 70 mm in diameter.

3.7.2.1.2 Stern ramp sides shall, in general, be carried downwards to the shell plating and forward to the after peak bulkhead and shall be smoothly tapered into deck girders and transverses.

3.7.2.1.3 Where the catch is dragged onto the deck, it is recommended that the stern ramp be longitudinally framed with transverses fitted at intervals not exceeding four frame spacings. The stern ramp longitudinals shall be spaced not more than 600 mm apart.

In vessels where special transport means are used to carry the catch onto the deck, the stern ramp shall be framed transversely.

3.7.2.2 The construction of ships having a side trawling arrangement.

3.7.2.2.1 1 It is recommended that vessels more than 30 m in length be fitted up with a forecastle.

3.7.2.2.2 Within the location of each gallow, determined as the distance between sections at three spacings forward and aft of the gallow ends, the strengthening shall be as follows:

intermediate frames shall be fitted extending from the upper deck down to a level not less than 0,5 m below the ballast waterline and having a section modulus not less than 75 % of that required by **2.5.4.2** for the frames in the 'tween deck space concerned;

the upper and lower ends of intermediate frames shall be secured to the decks, platforms and longitudinal intercostal members fitted between the main frames;

longitudinal intercostal members shall have the same section as intermediate frames and be aligned with them;

the upper longitudinal intercostal member shall be fitted not more than 350 mm below the upper deck;

bulwark stays shall be fitted at every frame.

3.7.2.3 Structures in processing shops.

3.7.2.3.1 Where the number of bulkheads in the processing shops located above the bulkhead deck is less than specified in 2.7.1.3 and where the distance between the bulkheads forming the boundaries of that space exceeds 30 m, partial bulkheads extending inboard for not less than 0,5 m of the 'tween deck height shall be fitted on the bulkhead deck at each side of the vessel in line with watertight bulkheads. The thickness of the partial bulkhead plating shall be not less than that of the top strake of the corresponding watertight bulkhead below the deck where the considered processing shop is located.

Partial bulkheads shall be strengthened with horizontal stiffeners in accordance with 1.7.3.2. Strengthening with vertical stiffeners is permitted with fitting the horizontal stiffeners between the side shell and the nearest vertical stiffener in compliance with 3.7.2.5.4.

Partial bulkheads shall be interconnected with deck transverses supported by pillars in a required number.

3.7.2.3.2 Where multi-tier deckhouses are arranged above the processing shops, the requirements of 2.12.5.2 for rigid members (bulkheads, partial bulkheads) to be fitted in such spaces shall be complied with.

3.7.2.4 In fishing vessels, bulwark stays shall be fitted at intervals equal to not more than two frame spacings.

3.7.2.5 Structural strengthening of ships mooring at sea.

3.7.2.5.1 In regions strengthened for mooring at sea, transverse framing shall be adopted for the vessel's sides. In single-deck ships, the deck and bottom in the above regions shall also be framed transversely. In multi-deck ships, transverse framing shall be adopted for the deck located on the fender level. Longitudinal framing of sides is permissible in the upper 'tween deck space only. In this case, the spacing of web frames shall not exceed three frame spacings or 2,4 m, whichever is less.

3.7.2.5.2 In the regions **A1**, **E1** and **E2** intermediate frames are recommended through the region length in fishing vessels and within fender areas in special purpose ships.

3.7.2.5.3 In any case, it is recommended that symmetrical sections be used and the minimum possible web depth be ensured for the particular section modulus.

3.7.2.5.4 Between the ship's side and vertical stiffener nearest to it, transverse bulkheads shall have horizontal stiffeners with a section height not less than 75 % of the vertical stiffener height. In ships with $L \leq 80$ m, horizontal stiffeners shall be spaced not more than 600 mm apart, and with $L \geq 150$ m, not more than 800 mm apart. For ships of intermediate lengths, linear interpolation may be used to determine this distance. The ends of horizontal stiffeners shall be welded to vertical stiffeners and sniped at the ship's sides.

3.7.2.5.5 The bulwark shall be inclined towards the centreline of the ship at not less than one-tenth or be fitted inboard of the ship's side at not less than one-tenth of its height.

3.7.2.5.6 Bilge keels of ships with the length $L \leq 80$ m shall be, as far as practicable, so arranged that a tangent drawn to the frame and passing through the outer free edge of the bilge keel would form an angle of not less than 15° with the vertical axis. For ships with the length $L \geq 150$ m, this angle may be zero. For ships of intermediate lengths, the above angle shall be obtained by linear interpolation.

3.7.2.5.7 The lower end attachments of hold frames shall be as required by 2.5.5.1.

In 'tween decks, the attachments of frame lower ends shall comply with the requirements of 2.5.5.3.

The frame ends shall be welded to the deck plating.

Upper ends of frames shall be carried to the deck plating and welded thereto. Beams shall be carried to the inner edges of frames with a minimal gap. Beam knees shall have a face plate or flange.

The ends of intermediate frames shall be attached to longitudinal intercostals, decks or platforms.

3.7.2.5.8 Side longitudinals shall be attached to transverse bulkheads with knees. The height and width of the knees shall comply with 1.7.2.2.

3.7.2.5.9 Bulwark stays welded to sheerstrake shall be so constructed as to prevent deck plating damage in case of bumping.

3.7.2.6 Besides the requirements of 3.10, the ice-strengthening structure of fishing vessels of ice class **Ice3** intended for systematic operation in ice conditions shall comply with the following requirements:

.1 for the case of transverse main framing, at least one load distributing side stringer shall be fitted in each grillage in way of region of ice strengthening **AI**, **A₁I**, **BI** and **CI** (refer to 3.10.1.3.2);

.2 bulbous forebody is not recommended;

.3 in the forepeak, the spacing of stringers and their dimensions, as well as stem dimensions, shall be in accordance with the requirements of 3.10 for fishing vessels of ice class **Ice4**;

.4 in the afterbody, provision shall be made for an appendage (ice knife) aft of the rudder to protect the latter on the sternway.

3.7.3 Design loads.

3.7.3.1 Design loads on ramp structures shall be determined as follows:

.1 the design pressure p , in kPa, on the ramp sides and deck in vessels where the catch is dragged in shall be determined by the formula

$$p = 6,5b, \quad (3.7.3.1.1)$$

Where the breadth of the ramp varies along its length, the minimum breadth shall be taken as the design value;

.2 in vessels equipped with a special wheeled catch-transport arrangement, the design load, in kN, for ramp deck plating shall be determined by the formula

$$p = 27(G_1 + G_2) / n_w, \quad (3.7.3.1.2)$$

where n_w – number of the wheel axes of the arrangement.

3.7.3.2 For factory decks, the design pressure p , in kPa, shall be determined by the formula

$$p = 15G / S_d. \quad (3.7.3.2)$$

3.7.3.3 The design pressure p , in kPa, on the sides and superstructure sides of ships moored at sea shall be determined by the following formulae

$$p = \alpha_1 \alpha_2 \alpha_3 (\beta_1 + \beta_2 \sqrt{\Delta z \cdot 10^{-3} - 0,464}), \quad (3.7.3.3)$$

where α_1 – shall be adopted from Table 3.7.3.3-1 depending on the ship displacement and the sea conditions specified for mooring at sea;

$\alpha_2, \alpha_3, \beta_1, \beta_2$ – shall be adopted from Table 3.7.3.3-2 and 3.7.3.3-3 depending on the ship purpose and the region of strengthening;

Δ – design ship displacement, in t. For a fishing vessel Δ displacement to the summer load waterline;

For a special purpose ship Δ shall not be taken greater than 7500 t;

z – distance in m, from the mid-span of member calculated to the summer load waterline. Where a special purpose ship has the freeboard depth $h_1 = D - d$ greater than the freeboard depth $h_2 = D - d$ of the biggest fishing vessel, the value of z shall be reduced by the difference of

$h_1 - h_2$. In any case, z shall not be less than 1,0 m. in regions A1, E1, E2 $z = 1,0$ m.

Table 3.7.3.3-1 Factor α_1

Ship displacement, in t	Sea state No		
	4	5	6
≤ 2000	1,00	1,15	1,60
> 2000	0,82	1,00	1,16

Table 3.7.3.3-2 Factor α_2

Factor α_2	Region of ice strengthening			
	A1 – A7	E1	E2	E3 – E6
	1,0	1,1	0,8	$1 + 0,05n^{1/3}$

n – number of moorings, during a voyage, alongside the ship whose displacement has been adopted as the design value in Formulae (3.7.3.3). For regions E3 – E6 α_2 is taken not less 1,1 and not greater than 1,4.

Table 3.7.3.3-3

Factors	Region of ice strengthening		
	A1, E1, E2	A2 – A4, E3, E4	A5 – A7, E5, E6
α_3	1,0	$1 / (0,22z + 0,6)$	$1 / (0,12z + 1,28)$
β_1	190	129	
β_2	51	59	

3.7.3.4 For fishing vessels of ice class **Ice3** intended for systematic operation in ice conditions, the ice load parameters shall be determined on the basis of the following provisions:

.1 in the forward region of ice strengthening A, the load parameters shall be determined in accordance with the requirements of **3.10** for the ice class **Ice3**. In the case of a bulbous forebody, the rake angle of frame β shall be determined as stipulated in **3.10.3.2.1** for fishing vessels of ice class **Ice4**;

.2 in the intermediate region of ice strengthening A_1 , the ice load parameters shall be taken equal to:

$$p_{A_1 I} = 0,75 p_{AI};$$

$$p_{A_1 II} = 0,75 p_{AII};$$

$$b_{A_1} = b_A;$$

$$l_{A_1}^H = l_A^H, \quad (3.7.3.4.2)$$

where: p_{AI} , p_{AII} , b_A , l_A^H - ice load parameters for the forward region A, as determined in accordance with the requirements of **3.10**, with due regard for **3.7.3.4.1**;

.3 in the midship region of ice strengthening B, the ice pressure, in kPa, is determined by the formula

$$p_{B1} = p^{\circ}_{B1} k_B, \quad (3.7.3.4.3)$$

where: p°_{B1} - ice pressure in midship region (B) according to **3.10.3.2.3**;

$$k_B = 2k_1, \text{ but not less than } 1;$$

;

$$k_1 = \frac{r^2}{\sqrt{\Delta/1000}} (l_k/L - 0,18);$$

$$r = \frac{17,4 P_b^{1/2} a^{1/2} - B^2}{57,3 P_b^{1/3}};$$

Δ — displacement, in t, to summer load waterline;

P_b — shaft power, in kW, determined with due regard for power take-off in the trawling condition;

l_k — distance, in m, from forward perpendicular to a section aft where the reduction of summer load waterline breadth begins.

The height and length (b_B and l_B^H) to which the midship region is covered by the ice load shall be determined in accordance with **3.10.3.3.3** and **3.10.3.4.3**.

.4 the ice pressure, in kPa, in the aft region of ice strengthening C is determined by the formula

$$p_{C1} = p^{\circ}_{C1} k_C, \quad (3.7.3.4.4)$$

where: p°_{C1} - ice pressure in the aft region according to **3.10.3.2.4**;

$$k_C = 2,5k_1, \text{ but not less than } 1;$$

for k_1 — refer to **3.7.3.4.3**.

The height and length (b_C and l_C^H) to which the aft region is covered by the ice load shall be determined in accordance with **3.10.3.3.4** and **3.10.3.4.4**.

3.7.4 Scantlings of structural members.

3.7.4.1 Requirements for the scantlings of stern ramp framing.

3.7.4.1.1 The section modulus of longitudinals, beams and deck transverses of the stern ramp is to be determined according to **1.6.4.1**, taking:

p — as obtained from (3.7.3.1-1) for vessels where the catch is dragged in or (3.7.3.1-2) — for vessels where the catch is carried onto the deck by a special wheeled arrangement;

m — as obtained from Table 3.7.4.1.1 for vessels where the catch is dragged in;

$m = 9,3l^2\sqrt[4]{a/l}$ – for vessels where the catch is carried onto deck by a special wheeled arrangement;
 $k_{\sigma} = 0,6$.

Таблиця 3.7.4.1.1 Коефіцієнт m

Stern ramp framing	Fishing vessels	Special purpose ships
Deck longitudinals	11,3	7,9
Beas and deck transverses	12,6	8,8

3.7.4.1.2 The section modulus, in cm^3 , of stern ramp side stiffeners shall not be less than determined by Formula 1.6.4.1 with the design load p as determined by Formula (3.7.3.1-1), $k_{\sigma} = 0,9$, $m = 17,0$ and $22,6$ for fishing vessels and special purpose ships respectively. The stiffener span l shall be adopted equal to the maximum distance between the ramp deck and the nearest deck above or to the distance between two decks adjoining the ramp side, but shall not be less than 2,6 m.

In vessels engaged in pelagic fishing, the section modulus of ramp side stiffener, in cm^3 , shall not be less than

$$W = 45,5(1 - 0,5 / l)[(820 / \sigma_n) - (l / a)]\omega_c, \quad (3.7.4.1.2)$$

In no case shall the section modulus of stern ramp side stiffeners be less than required in 2.5.4.2 for the frames of upper 'tween deck and superstructure.

3.7.4.1.3 The length of thickened ramp deck plating sections along the ramp length shall be equal to: the ramp width at least, if measured forward of the ramp edge, in way of bottom rounding; double ramp width at least in way of top rounding.

3.7.4.1.4 Where the connection of the ramp side with transom plating is rounded, the thickness of the plating strake not less than 700 mm broad, if measured from the ramp deck plating, shall not be less than 20 mm.

Ramp thickness thinning may be permitted while installing doubling plates.

If a welded half-round bar not less than 70 mm in diameter is fitted to the junction of the rounding and the flat part of the side, but not farther than 200 mm from the transom, the plating thickness may be adopted in accordance with the requirements of 3.7.4.1.6.

3.7.4.1.5 For vessels not engaged in pelagic fishing, the plating strakes of ramp sides shall be thickened, in way of connection with the transom and along the ramp deck, to a value not less than required under 3.7.4.1.6.

The thickened side plating strakes fitted along the ramp length shall have a breadth not less than 0,4 of the ramp breadth, or 1,0 m, whichever is greater. The lower edge of those strakes shall coincide with the ramp deck in vessels where the catch is dragged in and be level with the catch stowage surface in vessels where the catch is carried onto the deck by a wheeled arrangement.

If measured forward of the rounding-to-flat-side-junction line, the length of thickened section of the side plating in way of transom shall not be less than 0,5 of the ramp breadth.

3.7.4.1.6 For vessels where the catch is dragged in, the plating thickness of ramp deck and sides, in mm, shall not be less than determined by Formula (1.6.4.4), taking:

$m, \Delta s$ - to be adopted from Table 3.7.4.1.6;
 p - as determined by Formula (3.7.3.1.1);
 $k_{\sigma} = 0,8$;
 $k = 1$.

Table 3.7.4.1.6

Ramp structure	Location along ramp length	Fishing vessel		Special purpose ship	
		m	Δs , in mm	m	Δs , in mm
Deck	Bottom rounding and sterncounter plating	26,8	10,0	26,8	10,0
	Mid-region	26,8	5,5	26,8	5,5
	Top rounding	26,8	9,5	26,8	5,5

Sides	In way of friction	25,9	5,5	21,9	5,5
	Elsewhere on deck	25,9	4,5	21,9	4,5

3.7.4.1.7 Where doubling plates are fitted on the ramp deck in way of bottom rounding or top rounding or where devices to prevent excessive wear of stern ramp plating with wire ropes are installed, the plating thickness may be adopted as for the mid-region.

3.7.4.1.8 In vessels engaged in pelagic fishing, the lower strake of the side having a width from the stern ramp plating to a point at least 100 mm above the upper half-round bar shall have a thickness s , in mm, not less than

$$s = 2 \cdot 10^4 a_s / \sigma_n + 1, \quad (3.7.4.1.8)$$

where: a_s – distance, in m, between adjacent edges of half-round bars.

3.7.4.1.9 Whatever the mode of carrying the catch along the stern ramp, the thickness of ramp plating in vessels of all types shall be 2 mm greater than required by **2.2.4.8** for the shell plating. This thickness shall be maintained on the length from the stern ramp end to a line at least 600 mm above the bulkhead deck within the particular section of the vessel length. Forward of this region the thickness of stern ramp plating shall be 2 mm greater than required under **2.6.4.1.5** for the upper deck plating at ends.

3.7.4.1.10 On a length at least 1,0 m forward of the stern ramp edge and at least over the whole ramp breadth, the stern-counter plating shall be 1 mm thicker than stipulated under **2.2.4.1**.

3.7.4.2 Requirements for the member scantlings of vessels having a side trawling arrangement.

3.7.4.2.1 In vessels over 30 m in length, the side plating and sheerstrake thickness between the gallows, determined as the distance between the section three spacings forward of the fore end of forward gallow and the section three spacings abaft the after end of after gallow, shall be 1 mm greater than stipulated under **2.2.4.1**.

3.7.4.2.2 Within the location of each gallow, to be determined in accordance with **3.7.2.2.2**, provision shall be made for strengthening as follows:

sheerstrake thickness to be increased by 2 mm;

thickness of strake adjacent to sheerstrake to be increased to equal that of the sheerstrake between gallows;

deck stringer thickness to be increased by 3 mm as compared to that required by **2.6.4.1**;

bulwark plate thickness to be increased by 2 mm as compared to that required by **2.14.4.1**.

3.7.4.3 Requirements for member scantlings of holds and fish handling spaces.

3.7.4.3.1 The section modulus of factory deck beams and longitudinals shall be determined as required by **2.6.4** with the design pressure according to **3.7.3.2** where it exceeds that required by **2.6.3**.

3.7.4.3.2 In holds and fish handling spaces in which non-packed salted catch or salt is stored or which are exposed to the detrimental effect of catch wastes and sea water, the plating thickness shall be increased by 1 mm as compared to that required by the relevant sections of these Rules. Where the structure is so influenced from both sides, relevant thickness shall be increased by 2 mm.

3.7.4.3.3 The vertical web plate thickness of coamings not acting as deck girders shall not be less than the deck plating thickness, or 7 mm, whichever is greater.

3.7.4.4 Requirements for member scantlings of ships mooring at sea.

3.7.4.4.1 The side plating and sheerstrake thickness of ships below 80 m in length shall be by 1 mm greater than required under **2.2.4.8**.

3.7.4.4.2 In strengthened regions, the side plating and sheerstrake thickness, in mm, shall not be less than

$$s = 21,7 a \sqrt{p / (k_n R_{eH})} - 0,242 + \Delta s \quad (3.7.4.4.2)$$

where: a – frame spacing, in mm. If panting frames are provided, a is the distance between main and panting frames;

p – as defined under **3.7.3.3**;

$k_n = 1,1$;

$\Delta s = 4,0$ mm for region **A1** in case trawling is effected from the vessel side;

$\Delta s = 1,2$ mm for regions **A2 ÷ A7**, **E3 ÷ E6**;

$\Delta s = 3,0$ mm mm elsewhere.

3.7.4.4.3 In regions **A1**, **E1** i **E2** the section modulus of frames, in cm^3 , shall not be less than

$$W = pab(2l - b) \omega_c \cdot 10^3 / (mk_n R_{eH}), \quad (3.7.4.4.3)$$

where: p – as determined by Formula 3.7.3.3;

a – spacing, in m, of main frames;

$b = 1,5$ m;

$m = 20,4k_1k_2(1 + k_3k_4)$;

k_1, k_2, k_3 – shall be adopted from Table 3.7.4.4.3 proceeding from the number of load distributing side stringers fitted;

$k_4 = 0$ – where no panting frames are fitted;

$k_4 = 0,69$ – if panting frame ends terminate at longitudinal intercostal members;

$k_4 = 1$ – if the end attachments of main and panting frames are similar;

$k_n = 1,1$;

l – frame span, in m, as measured along the chord between the upper edge of inner bottom plating or floor face plate and the lower edge of deck at side (side stringer where web frames are fitted);

for ω_c – refer to 1.1.5.3.

Table 3.7.4.4.3

Factor	No load distributing side stringers	One load distributing side stringer	Two load distributing side stringers or more
k_1	1,0	$1,12 + 0,038l\bar{\omega}/a$	$1,27 + 0,039l\bar{\omega}/a$
k_2	$1 + 6,8\sqrt{[f(f/l + 0,28)/l] - 12,5f_1/l}$	$1 + 7f/l - 8f_1/l$	
k_3	1,0	0,75	0,65

$\bar{\omega} = W_c/W$ – section modulus ratio of load distributing side stringer and frame;
 f – distance, in m, between a section at the lower support of frame and a tangent to the frame contour in way of the section at the upper support, as measured normal to the tangent (refer to Fig. 3.7.4.4.3);
 f_1 – maximum deflection of frame according to Fig. 3.7.4.4.3, in m.

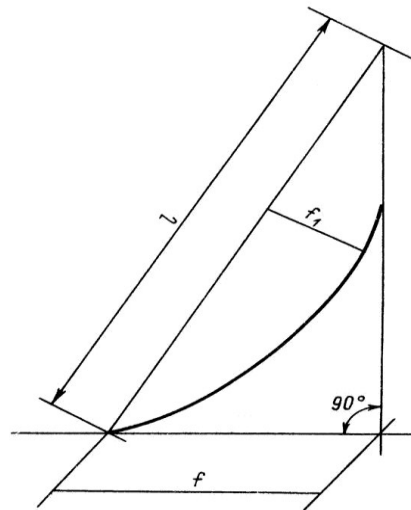

Fig. 3.7.4.4.3

3.7.4.4.4 In regions **A2 ÷ A7, E3 ÷ E6** the section modulus of frames, in cm^3 , shall not be less than determined by Formula 3.7.4.4.3. The value of p shall be determined by Formula 3.7.3.3.

Where the actual shell plating thickness is greater than 8 mm, p may be reduced by the value

$$\Delta p = (2,9 + l)s^2 R_{eH(o)} \cdot 10^{-3} / (al), \quad (3.7.4.4.4)$$

where: s – actual shell plating thickness, in mm, but not greater than 20 mm;

l – frame span, in m;

$R_{eH(o)}$ – yield stress, in MPa, of shell plating material;

a – main frame spacing, in m;

$b = 2,2$ m;

$$m = 25 k_1 k_2 k_4 / k_3;$$

$k_1 = 1,3$ – for regions **E3** ÷ **E4** of special purpose ships;

$k_1 = 1$ – elsewhere;

$k_2 = 1$ – where no load distributing stringers are fitted;

$k_2 = 1,12 + 2,46\bar{\omega}/a(8,6 - 1)$ – with one load distributing stringer;

$k_2 = 1,15 + 5,06\bar{\omega}/a(8,6 - 1)$ – with two load distributing stringers or more;

$\bar{\omega} = W_c/W$ – section moduli ratio of load distributing stringer and frame;

$k_3 = 2a$ – for the fender areas of special purpose ships and within $(0 \div 0,25)L$ of forward perpendicular in fishing vessels;

$k_3 = (2a - 0,1)$ – within $(0 \div 0,2)L$ of aft perpendicular in fishing vessels;

$k_3 = (2a - 0,2)$ – elsewhere;

$k_4 = 1$ – where no panting frames are fitted;

$k_4 = k'_3(1 + 0,5 k_1 k'_3)/k_3$ – where panting frames are fitted;

the factor k'_3 is determined in the same way as k_3 , with a equal to the spacing of main and panting frames;

$k_n = 1,1$.

3.7.4.4.5 If longitudinal framing system is applied for 'tween deck spaces, the section modulus, in cm^3 , of side longitudinals shall not be less than

$$W = 24paa_p^2 \omega_c / R_{eH}, \quad (3.7.4.4.5)$$

where: p – as determined by Formula **3.7.3.3**;

a – spacing, in m, of longitudinals;

a_p – web frame spacing, in m.

3.7.4.4.6 Where superstructure sides of ships mooring at sea are inclined to the centre line at not less than $1/10$ or fitted inboard at not less than $1/10$ of their height, no additional strengthening as per **3.7.4.4** is required.

Where the inclination of superstructure sides to the vessel side or the distance between those and the vessel side is less than specified above, the strengthening of their frames and shell plating shall be determined by linear interpolation proceeding from the requirements of **3.7.4.4** and **2.2.4.1**, **2.5.4.2**.

3.7.4.5 The member scantlings in the ice strengthened regions of fishing vessels of ice class **Ice3**, which are intended for systematic operation in ice conditions shall be determined in accordance with **3.10.4** where the ice load parameters are as stipulated in **3.7.3.4** bearing the following specification in mind. When determining shell plating thickness in the intermediate region of ice strengthening in accordance with **3.10.4.1** the annual average thickness reduction of shell plating as a result of corrosion wear and abrasion shall be adopted as $u = 0,25$ mm/year.

3.7.5 Special requirements.

3.7.5.1 Stern ramp structure.

3.7.5.1.1 Transom plating shall be protected from excessive wear with half-round steel bars of at least 70 mm in diameter, which shall be fitted inclined and secured by welding.

3.7.5.1.2 Half-round steel bars of at least 70 mm in diameter shall be welded along the junction line of rounding and flat side, but not farther than 200 mm from the transom.

3.7.5.1.3 In vessels engaged in pelagic fishing, stern ramp sides shall be stiffened with longitudinal half-round steel bars of at least 70 mm in diameter, welded to the sides and spaced not more than 200 mm apart. The edge of the upper bar shall be not less than 650 mm above the ramp deck plating.

3.7.5.1.4 Suitable devices are recommended to prevent excessive wear of ramp plating with wire ropes when dragging the catch. Where the rated winch pull exceeds 30 kN on each wire rope, such devices are compulsory.

Devices preventing excessive wear of plating may be substituted by doubling plates in the thickened areas of top and bottom rounding over the full breadth of the ramp, and doubling strips at least 400 mm wide may be fitted at the sides over the rest of the ramp length.

3.7.5.2 Within the location of each gallow complying with **3.7.2.2.2**, bulwark, sheerstrake and shell plating above ballast waterline shall be protected with half-round steel bars fitted inclined and secured by welding.

3.7.5.3 The 'tween deck height in way of heavy items of machinery and equipment installed in fish handling spaces shall not exceed 3,5 m.

3.7.5.4 When determining the requirements for sternframe scantlings of ships having the length $L < 60$ m the design length and width of a solid rectangular propeller post shall be those stipulated under **2.10.4.3**, as increased by 10 %.

3.8 SUPPLY VESSELS

3.8.1 The requirements of this Chapter apply to supply vessels, including supply of MODU/MFP, standby vessels and anchor handling vessels.

Structural members not covered by this Chapter shall comply with the requirements of Sections **1** and **2**.

3.8.2 Construction.

3.8.2.1 Provision shall be made for longitudinal fenders at the weather deck and the deck below level.

3.8.2.2 The fenders shall extend not less than $0,02L$ forward of the section where the weather deck has its full breadth.

3.8.2.3 The weather deck shall be efficiently stiffened in way of deck equipment or cargo which load exceeds the design deck load value.

3.8.2.4 Shell plating in way of stern rollers and fenders areas shall be efficiently stiffened.

3.8.2.5 In the forward region $0,2L$ from the forward perpendicular (FP) the ends of framing members of hull, forecastle and the first tier of deckhouse shall be connected by brackets.

3.8.3 Design loads.

3.8.3.1 Design loads on hull structures shall be taken in compliance with Sections **1** and **2**.

3.8.3.2 For determining the scantlings of deck stiffeners according to **3.8.2.4** as well as scantlings of the supporting pillars, the load shall be calculated with due regard to the inertia force components in horizontal and vertical direction due to the vessel's rolling and pitching.

3.8.4 Scantlings of structural members.

3.8.4.1 The thickness of the side shell plating shall be 1 mm greater than required by **2.2.4**. In any case the thickness of the side shell plating shall not be taken less than 9,0 mm.

3.8.4.2 In fenders area the thickness of the side shell plating shall not be taken less than

$$s_{\min} = (6 + 0,05L) \cdot a/a_0,$$

where: a – main framing spacing;

a_0 – normal spacing according to **1.1.3**;

a/a_0 shall not be taken less than 1,0.

3.8.4.3 If fenders are suspended in the length, the thickness of unprotected side areas shall be 50 % greater than required by **3.8.4.2**. The reinforced region shall be extended 600 mm transversely below deck or 'tween deck, as far as applicable.

3.8.4.4 Scallop and one-sided welds shall not be used in connections between side frames and shell plating.

3.8.4.5 Section modulus of hold, 'tween deck or forecastle frames shall not be less than specified in **3.7.4.4**, with p , determined by Formula 3.7.3.3, $\alpha_1 = 1,16$ and $\alpha_2 = 1,0$. Factors α_3 , β_1 and β_2 are taken from Table 3.7.3.3-3 as for region A1.

However, no needs to take the section modulus of side longitudinals, hold or 'tween deck frames more than 1,25 times as required in **2.5.4**.

3.8.4.6 The thickness of weather deck plating shall be determined from **2.6.4**, but it shall not be less than 8,0 mm.

If the weather deck is intended to carry deck cargoes, the thickness shall be increased by 1,0 mm as required by **2.6.4**.

If the weather deck is intended to carry anchors and anchor chain cables, the thickness shall be increased by 2,5 mm as required by **2.6.4**.

3.8.4.7 The thickness of the weather deck stringer in the region of rescue zone shall be not less than

$$s_{\min} = (7 + 0,02L) \cdot a/a_0,$$

where: a – shall not be less than;

a_0 – normal spacing according to 1.1.3;
 a/a_0 shall not be taken less than 1,0.

3.8.4.8 The scantlings of weather deck framing members shall be determined as required by 2.6.4 with a design load corresponding to the specified value but not less than 35 kPa.

3.8.4.9 While determining reinforcements for stern rollers and mooring winches, the requirements of 4.3.5, Part III "Equipment, Arrangements and Outfit" shall apply.

Thickness of plate structures in way of stern rollers and shark jaws shall be at least 25 mm.

3.8.4.10 The section modulus of vertical frames of fronts, sides and after ends of deckhouses located on the forecastle deck shall be not less than required by 2.12.4.5.2.

The assumed head p , in kPa, shall not be taken less than given in Table 3.8.4.10.

Table 3.8.4.10

Deckhouse tier	p , in kPa			s_{min} , in mm
	Front bulkhead	Side bulkhead	After bulkhead	
First	90	60	25	$10,8a$
Second and above	75	50	25	$10a$

Note. a – spacing between bulkhead vertical frames.

3.8.4.11 The plate thickness of the side and end bulkheads of deckhouses shall be not less than indicated in Table 3.8.4.10.

3.8.4.12 Thickness of bulwark plating shall be at least 7 mm, and the width of the stanchion lower edge measured along the weld shall be not less than 360 mm. The distance between stanchions shall not exceed two spacings or 1,3 m, whichever is the lesser.

3.9 TUGS

3.9.1 General and symbols.

3.9.1.1 The requirements of this Chapter apply to all tugs irrespective of purpose or service area.

3.9.1.2 Structural items not covered by this Chapter shall comply with the requirements of Sections 1 and 2.

3.9.1.3 For the purpose of this Chapter the following symbols have been adopted:

b_s – width of stem cross section, in mm;

l_s – length of stem cross section, in mm.

3.9.2 Construction.

3.9.2.1 Plate floors shall be fitted at each frame. Where the double bottom is omitted, the floors shall have a symmetrical face plate.

3.9.2.2 Where a main frame span exceeds 3,0 m, load distributing side stringers shall be fitted along the length of the ship except for the engine room.

3.9.2.3 In the engine room, web frames shall be fitted between the inner bottom (floor face plates) and the upper deck at a distance not exceeding four spacings. Web frames shall be fitted at main engine ends. The distance specified may be increased provided side grillage structure strength and stiffening are verified by direct calculation in accordance with the RS-agreed procedures.

3.9.2.4 A fender shall be fitted at upper deck and long forecastle deck level.

3.9.2.5 Areas to which concentrated loads are applied (e.g. due to towing winches) shall be additionally strengthened.

3.9.2.6 The stems of harbour tugs shall have rounded shape above the summer load waterline.

3.9.3 Design loads.

Design loads on hull structures of tugs shall be assumed in compliance with the requirements of Sections 1 and 2.

3.9.4 Scantlings of structural members.

3.9.4.1 The minimum plating thickness of shell and upper deck as well as of watertight bulkheads shall not be less than 5 mm.

3.9.4.2 The thickness of shell plating adjacent to the stem shall not be less than stipulated under 2.2.4.6.

The shell plating thickness in way of the engine room, when located aft, shall not be less than required

for the midship region.

3.9.4.3 When determining the section modulus of the web frames in accordance with **2.5.4.5**, the distance measured from the inner bottom plating (floor upper edge) and the upper deck at side shall be taken as the design span.

3.9.4.4 The scantlings of load distributing side stringers shall be determined in accordance with **2.8.2.7**.

3.9.4.5 Within the region from the keel to the summer load waterline, the cross-section of a rectangular solid bar stem shall not be less than:

$$l_s = 1,6L + 100; \quad (3.9.4.5-1)$$

$$b_s = 0,5L + 25. \quad (3.9.4.5-2)$$

The scantlings and location of brackets for strengthening the stem shall be determined proceeding from **2.10.4.1.3**.

The stem shall be extended abaft the fore peak bulkhead for not less than three spacings.

Ship-handling tugs are not permitted to have reduced cross-section and scantlings of the stem (if constructed of steel plates) above the summer load waterline.

The steel plates of the stem shall be strengthened over their length with horizontal brackets spaced not more than 0,6 m apart, the plate thickness of the stem determined in accordance with **2.10.4.1.2 being not reduced**.

3.9.4.6 Rectangular solid propeller posts shall have scantlings from the keel to the counter not less than:

$$l_s = 1,5L + 100; \quad (3.9.4.6-1)$$

$$b_s = 1,8L + 25. \quad (3.9.4.6-2)$$

The sternframe shall be attached according to **2.10.2.2.3** to two floors, whatever the length of the tug may be.

3.9.4.7 The thickness of the bulwark plating shall be taken according to **2.14.4.1**, but not less than 4 mm.

The section modulus of bulwark stays shall be determined in accordance with **2.14.4.2** where $m = 1,5$. Bulwark stays shall be fitted not farther than at alternate frames.

Bulwark stays welded to the sheerstrake plate may have a flexible element in their structure. The bulwark shall be inclined to the centre line of the vessel at not less than 7° .

3.9.5 Special requirements.

3.9.5.1 For unrestricted service tugs above 40 m in length, the number of watertight bulkheads shall be not less than four.

3.9.5.2 For requirements to ice strengthening of tugs refer to **3.12**.

3.10 STRENGTHENING OF ICE CLASS SHIPS AND ICEBREAKERS

3.10.1 General and requirements.

3.10.1.1 Application.

3.10.1.1.1 The requirements of this Chapter apply to self-propelled ice class ships and icebreakers, as well as to ships which may be given the same status proceeding from the conditions of their ice navigation. Requirements for polar class ships (refer to **2.2.3.1**, Part I "Classification") are specified in **3.11**.

The requirements for the Baltic ice class ships (refer to **2.2.3.1**, Part I "Classification") are given in **3.12**.

3.10.1.1.2 Self-propelled ice-strengthened ships which comply with the requirements of this Chapter are assigned an ice class mark in their class notation in accordance with **2.2.3**, Part I "Classification".

3.10.1.1.3 Requirements of this Chapter are supplementary with regard to those of other chapters of these Rules which apply to a particular ship, and they establish the minimum strength level necessary to withstand ice loads, as well as hull structure, proceeding from the ice class mark in the class notation.

3.10.1.2 Requirements to hull configuration.

3.10.1.2.1 The hull configuration parameters α , α_0 , β , φ , in deg., shall be measured in conformity with Figs. 3.10.1.2-1 ÷ 3.10.1.2-4.

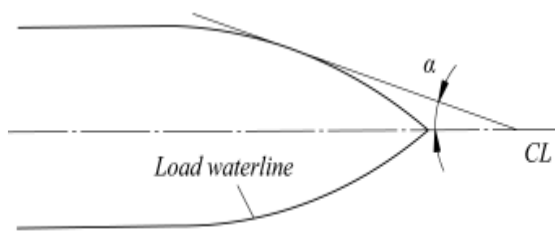

Fig.3.10.1.2-1:
 α – slope of design ice waterline at the section considered, in deg.

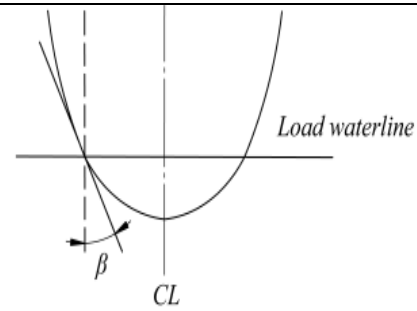

Fig.3.10.1.2-2:
 β – slope of frame on the level of design ice waterline at the section considered, in deg.

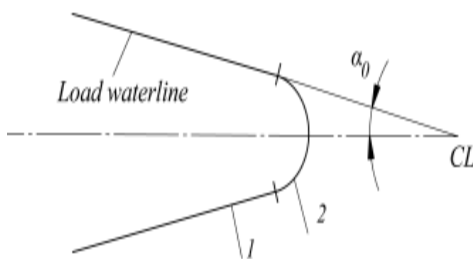

Fig.3.10.1.2-3:
 α_0 – slope of design ice waterline at the fore perpendicular, in deg.; 1 - shell plating; 2 - stem

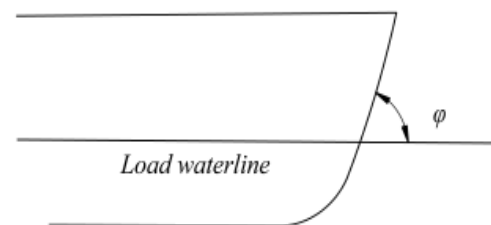

Fig.3.10.1.2-4
 φ – slope of stem on the level of design ice waterline, in deg.

3.10.1.2.2 The hull configuration parameters of ice class ships are recommended to be within the limits stated in Table 3.10.1.2.2.

In the forward and intermediate region of ice strengthening of **Ice6**, **Ice5**, **Ice4** ice class ships and icebreakers, there shall be no areas of shell plating within which the configuration parameters β and α would simultaneously take the values $\beta = 0$ and $\alpha > 0$.

Table 3.10.1.2.2

Hull configuration parameter	Ice class			
	Ice6	Ice5	Ice4	Ice2, Ice3
φ , not greater than	30°	45°	60°	-
α_0 , not greater than	30°	40°	40°	50°
β_0 within 0,05L from fore perpendicular, minimum	40°	25°	20°	-

3.10.1.2.3 Hull configuration parameters of icebreakers.

For icebreakers, at 0 - 0,25L from the area of fore perpendicular within service draughts, straight and convex waterlines shall be used. The recommended entrance angles for above waterlines α_0 , are within the limits of $\alpha_0 = 22^\circ \div 30^\circ$.

At service draughts, the angle shall not exceed:

30° - for icebreakers of ice classes **Icebreaker1**, **Icebreaker2**;

25° - for icebreakers of ice classes **Icebreaker3**, **Icebreaker4**.

The cross section of stem shall be executed in the form of a trapezoid with a bulging forward face.

For icebreakers with standard bow lines, slope angles of frames shall be adopted from Table 3.10.1.2.3.

In way of construction water line, frames shall have a straight-lined or moderately convex shape. The design water line shall cover the blade tips of side propellers.

Table 3.10.1.2.3

Distance from section to fore perpendicular	0,1L	0,2L ÷ 0,25L	0,4L ÷ 0,6L	0,8L ÷ 1,0L
Permissible range of the angle variation β , in deg.	40° ÷ 55°	23° ÷ 32°	15° ÷ 20°	Approximately coinciding with the angles β of within 0 ÷ 0,2L

3.10.1.2.4 In the afterbody of icebreakers and **Ice6**, **Ice5** and **Ice4** ice class ships, there shall be an appendage (ice knife) aft of the rudder to protect the latter on the sternway.

3.10.1.2.5 No transom stern (with the transom coming in the region of ice strengthening) is permitted for icebreakers and **Ice6** ice class ships.

For **Ice4** and **Ice5** ice class ships the transom aft end is not recommended in the regions of ice strengthening.

When the flat transom of **Ice4** and **Ice5** ice class ships is in way of ice strengthening region, the minimum possible transom area in the ice strengthening region shall be provided.

Transom structural members in the ice strengthening region shall comply with the requirements for structural members in region **B1**.

3.10.1.2.6 For icebreakers and **Ice6** ice class ships ice class ships, there shall be a step in the lower part of the stem.

The height of the step shall be 0,1d at least. The transition from the step to the lower part of the stem shall be smooth.

3.10.1.3 Region of ice strengthening.

3.10.1.3.1 There are ice strengthening regions lengthwise as follows:

forward region - **A**;

intermediate region - **A1**;

midship region - **B**;

aft region - **C**.

There are ice strengthening regions transversely as follows:

region of alternating draughts and similar regions - **I**;

region from the lower edge of region **I** to the upper edge of bilge strake - **II**;

bilge strake - **III**;

region from the lower edge of bilge strake to the centre line - **IV**.

3.10.1.3.2 The length of regions of ice strengthening in ice class ships shall be determined on the basis of Fig. 3.10.1.3.2 and Table 3.10.1.3.2.

An ice loadline shall be determined as a loadline enveloping all the ship loadlines (heel and mass of ice in case of icing disregarded) possible during ice navigation.

Ballast waterline shall be determined as a waterline enveloping from below all the possible waterlines of the ship in service (heel and mass of ice in case of icing is disregarded).

For **Ice1** - **Ice3** ice class ships no intermediate region of ice strengthening will be established.

In this case, it shall be considered that the aft boundary of the forward region of ice strengthening coincides with the forward boundary of the midship region of ice strengthening.

Table 3.10.1.3.2

Parameter		Ice class				
		Ice6, Ice5	Ice4	Ice3	Ice2	Ice1
h_1 , in m	where $B \leq 20$ m	0,75	0,6	0,5		
	where $B > 20$ m	$(0,5B + 8)/24$	$(0,5B + 8)/30$	$(0,5B + 8)/36$		0,5
h_2 , in m		0,8	0,6	0,2		
h_3 , in m		$1,35 h_1$	$1,2 h_1$	$1,1 h_1$	h_1	
L_2 , in m		0,1L	0,05L	0,02L		-
L_3 , in m		0,05L	0,045L	0,04L	0,02L	
k_1		0,69	0,55	0,53	0,50	-

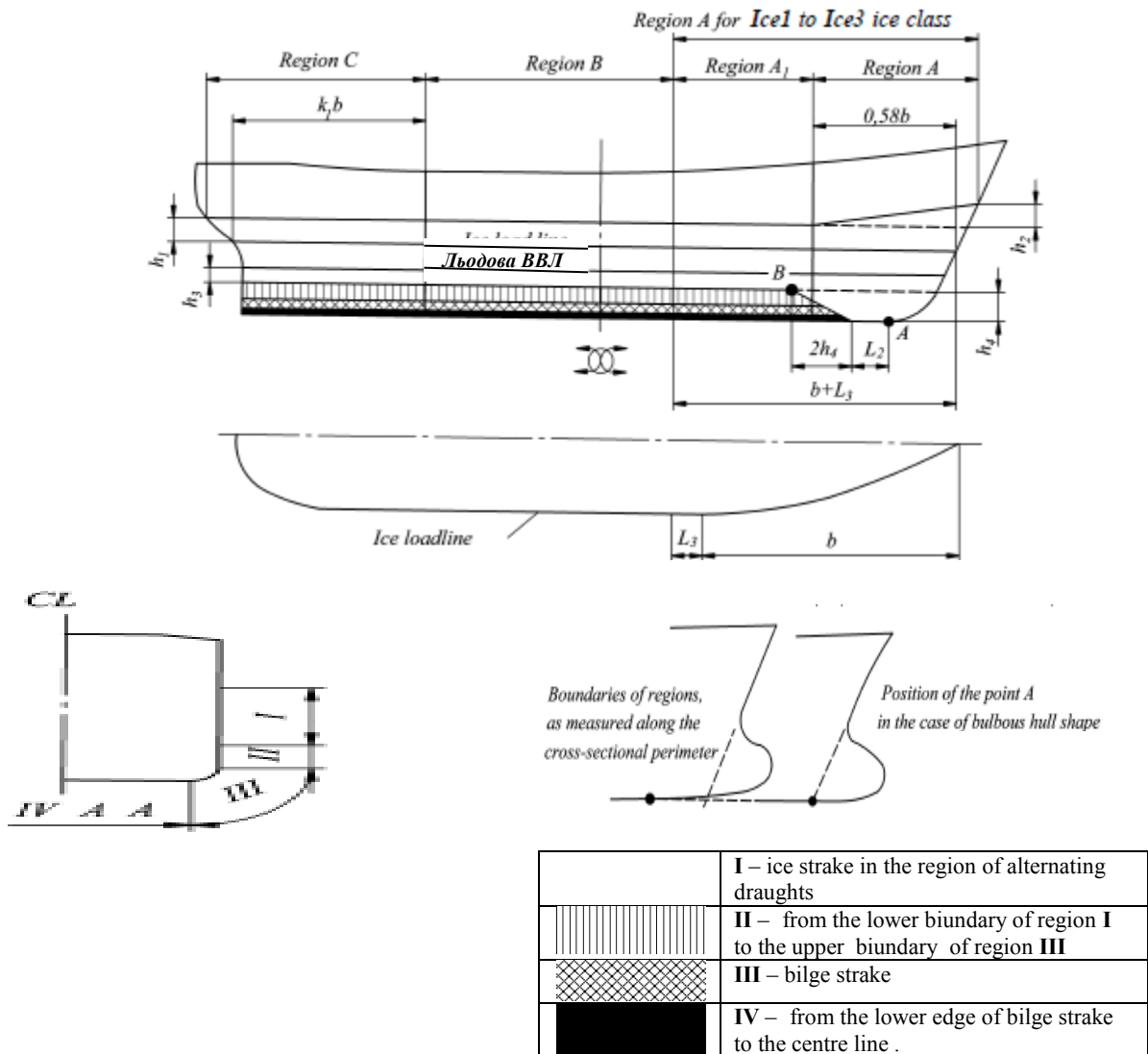

Fig.3.10.1.3.2. Regions of ice strengthening of ice class ships:

b – distance from the point of the ice loadline and stem intersection to the section where the ice loadline is the widest, but not greater than $0,4L$.

- Notes: 1. For **Ice1** ice class ships, the lower boundary of the region A is by h_3 distant from the ballast waterline.
 2. Point B shall not be further than the aft boundary of the region A₁.

For calculation procedures of this Chapter ice loadline shall be taken as the design ice waterline, unless stated otherwise.

3.10.1.3.3 The length of regions of ice strengthening in icebreakers shall be determined on the basis of Fig. 3.10.1.3.3 and Table 3.10.1.3.3.

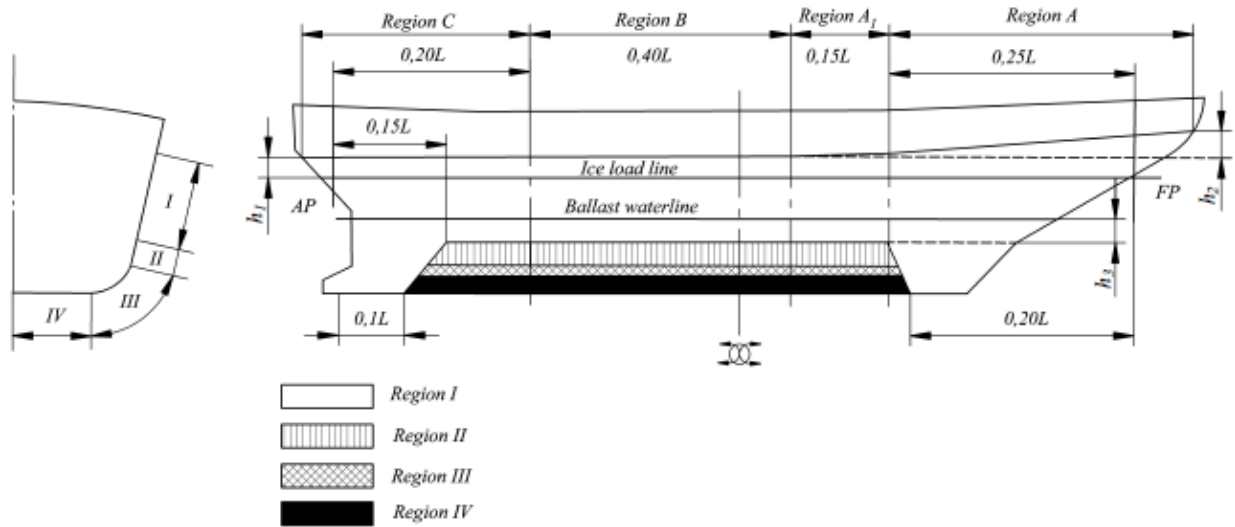

Fig. 3.10.1.3.3 Regions of ice strengthening of icebreakers

Table 3.10.1.3.3

Parameter		Ice class of icebreaker			
		Icebreaker4	Icebreaker3	Icebreaker2	Icebreaker1
h_1 , in m	where $B \leq 20$ m	1,0	0,8	0,75	
	where $B > 20$ m	$(0,5B + 12)/22$	$(0,5B + 7,6)/22$	$(0,5B + 8)/24$	
h_2 , in m		2	1,7	1,4	1,1
h_3 , in m		$1,9 + 1,6h_1 \geq 3,5$	$1,72 + 1,6h_1 \geq 3,0$	$1,6 + 1,6h_1 \geq 2,8$	$0,4 + 1,6h_1 \geq 1,6$

3.10.1.3.4 Proceeding from the ice class, the requirements of this Chapter apply to the regions of ice strengthening marked with «+» in Table 3.10.1.3.4. For the purpose of Table 3.10.1.3.4, the absence of this mark means that the particular region of ice strengthening is not covered by the requirements of this Chapter.

Table 3.10.1.3.4

Ice class	Vertical regioning															
	I				II				III				IV			
	A	A ₁	B	C	A	A ₁	B	C	A	A ₁	B	C	A	A ₁	B	C
Icebreaker4, Icebreaker3	+	+	+	+	+	+	+	+	+	+	+	+	+	+	+	+
Icebreaker2, Icebreaker1, Ice6	+															
Ice5	+	+	+	+	+	+	+	+	+	+	+		+	+		
Ice4	+	+	+	+	+	+	+		+	+			+	+		
Ice3	+		+	+	+											
Ice2	+		+	+												
Ice1	+															

3.10.2 Structure.

3.10.2.1 Side grillage structure transversely framed.

3.10.2.1.1 A grillage may include vertical girders of main framing which are denoted as conventional frames, vertical web members which are denoted as deep frames, and longitudinals which are denoted as stringers.

Conventional frames are subdivided into:

main frames in plane of floors or bilge brackets;
intermediate frames not in plane as floors or bilge brackets.

The intermediate frames are not mandatory within a side grillage. Not more than one intermediate frame may be fitted between main frames.

Stringers are subdivided into:

intercostal stringers by which joint taking-up of local ice loads by the frames is ensured.

It is recommended that the stringers shall be inter-costal;

side stringers by which a transition of forces is ensured from conventional frames which directly take up the ice load to deep frames or to transverse bulkheads.

Side grillage structures are permitted as follows:

grillage with transverse main frames which is formed by conventional frames of the same section and by intercostal stringers;

grillage with transverse web frames which is formed by conventional frames, side stringers and deep frames. Intercostal stringers may be fitted together with side stringers.

With a double-bottom structure available, the functions of deep frames are taken over by vertical diaphragms, and those of the side stringers, by horizontal diaphragms.

3.10.2.1.2 In icebreakers and **Ice5** ÷ **Ice6** ice class ships, frames shall be attached to decks and platforms with brackets; if a frame is intercostal in way of deck, platform or side stringer, brackets shall be fitted on both sides of it.

3.10.2.1.3 The end attachments of main frames shall comply with the requirements of **2.5.5**.

In icebreakers solid floors shall be fitted on each main frame.

The end attachments of intermediate frames shall comply with the following requirements.

In **Ice4** ÷ **Ice6** ice class ships and icebreakers, the bottom ends of intermediate frames shall be secured at margin plate stiffened with a lightened margin bracket (or a system of stiffeners) reaching up to longitudinal stiffeners or intercostal members and welded thereto (refer to Fig. 3.10.2.1.3-1).

Where there is no double bottom, the intermediate frames shall extend as far as longitudinal stiffeners or intercostal structure and welded thereto. The particular longitudinal stiffener or intercostal structure shall be fitted not higher than the floor face-plate level.

In **Ice1** ÷ **Ice3** ice class ships having monotonic main framing, the bottom ends of intermediate frames may be secured at intercostal longitudinal fitted 1000 mm beneath the lower boundary of region **I**.

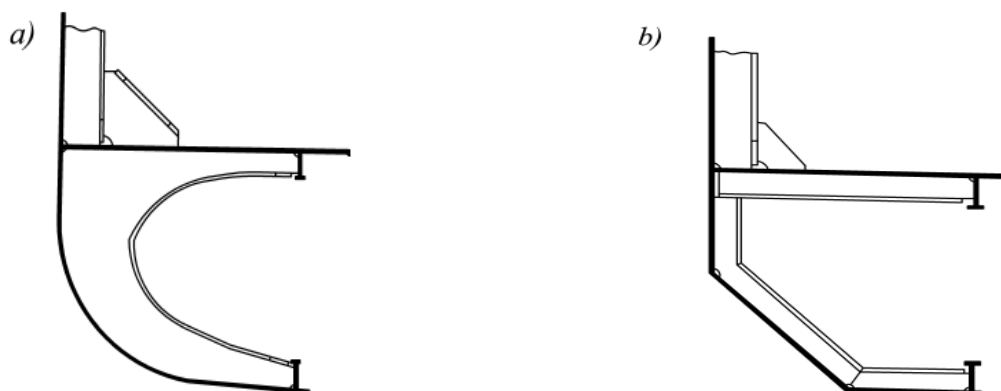

Fig. 3.10.2.1.3-1:

a - lightened margin bracket; *b* - system of stiffeners

In **Ice1** ÷ **Ice3** ice class ships with deep framing, it is permitted to secure the bottom ends of intermediate frames, except for the region **A** of ice class **Ice3**, at a longitudinal (which may be intercostal) fitted 1000 mm below the side stringer lying beneath the lower boundary of region **I** (refer to Fig. 3.10.2.1.3-2).

In this case, the web area and plastic modulus of the above side stringer shall not be less than required for a stringer fitted in region **I**.

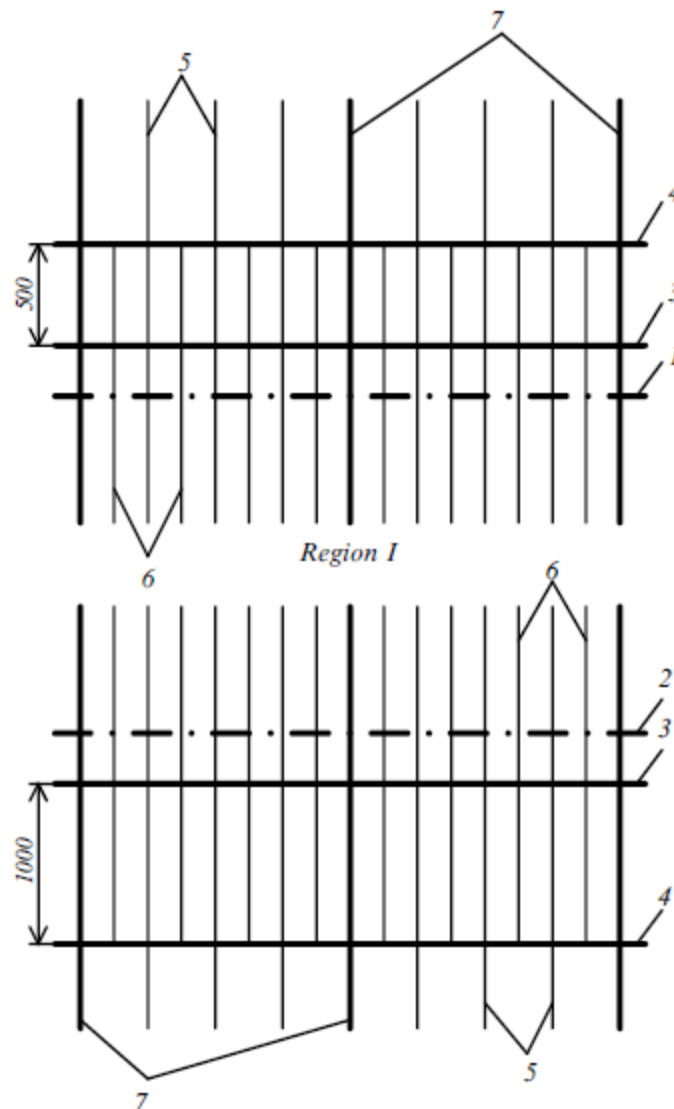

Fig. 3.10.2.1.3-2

Permissible method for securing the ends of intermediate frames in Ice1 - Ice3 ice class ships with deep framing:

- 1 - upper boundary of region I;
- 2 - lower boundary of region I;
- 3 - side stringer; 4 – intercostal longitudinal; 5 - main frames;
- 6 - intermediate frames; 7 - deep frames.

In icebreakers and **Ice4 ÷ Ice6** ice class ships, the upper ends of intermediate frames shall be secured on a deck or platform lying above the upper boundary of region I.

In **Ice1 ÷ Ice3** ice class ships having monotonic main framing, the upper ends of intermediate frames may be secured in way of an intercostal longitudinal fitted 500 mm above the upper boundary of region I.

In **Ice1 ÷ Ice3** ice class ships with deep framing, the upper ends of intermediate frames may be secured in way of a longitudinal (which may be intercostal) fitted 500 mm higher than the side stringer lying above the upper boundary of region I (refer to Fig. 3.10.2.1.3-2). In this case, the web area (and the ultimate section modulus of the above side stringer shall not be less than those required for a stringer fitted in region I.

3.10.2.1.4 In regions I and II of icebreakers and **Ice4 ÷ Ice6** ice class ships, intercostal and/or side stringers shall be fitted the distance between which or the stringer-to-deck or platform distance shall not exceed 2 m, as measured on a chord at side.

For region I of Ice1 ÷ Ice3 ice class ships, this distance shall not exceed 3 m.

Side stringers shall be fitted in the loadline and ballast water line regions. If there is a deck or platform lying on the same level, the side stringer may be omitted.

Stringers shall be attached to bulkheads by means of brackets.

3.10.2.2 Determining the supporting sections of frames in grillages with transverse framing.

3.10.2.2.1 The supporting sections of conventional and deep frames shall be found in supporting structures only. For frames, horizontal grillages (decks, platforms, bottom) are considered to be supporting structures. A supporting structure consists of plating (decks, platforms, double bottom) and framing connected thereto (beams, half-beams, floors, tank-side brackets).

Where there is no double bottom, the formulae to be found below shall be used on the assumption that the plating lies level with floor face plates.

3.10.2.2.2 The supporting section of a conventional frame is considered to be fixed, if one of the following conditions is met at least:

- the frame is connected to the framing of a supporting structure;
- the frame crosses the plating of a supporting structure.

A supporting section is considered to be simply supported, if a conventional frame is not connected to supporting structure framing and is terminated on the structure plating.

Where a conventional frame terminates on an intercostal longitudinal (intercostal stringer), its end is considered to be free, i.e. with no supporting section.



3.10.2.2.3 The position of a supporting section of a frame (conventional or deep frame) is determined in the following way.

Where the frame is connected to the supporting structure plating only, the supporting section coincides with the plating surface.

- Where the frame is connected to the supporting structure framing, the supporting section:
 - coincides with the face plate surface of the supporting structure frame in case of bracketless joint;
 - lies at bracket end where brackets with a straight or rounded and stiffened edge are concerned;
 - lies in the middle of the bracket side where brackets with a rounded free edge are concerned.

3.10.2.2.4 When determining the conditions of fixation and the position of supporting sections in typical structures, one shall be guided by Table 3.10.2.2.4 (the position of a supporting section is indicated with an arrow in the sketches of the Table), as well as by the requirements of 3.10.2.2.2 and 3.10.2.2.3.

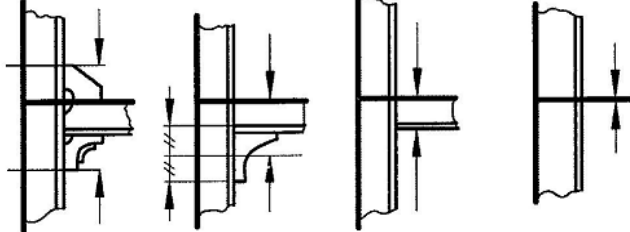
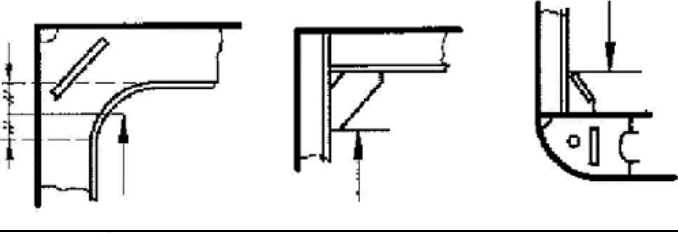
Table 3.10.2.2.4

Type of joint in way of the supporting section of the frame	Type of supporting section	Sketch showing structure and the position of supporting section therein
Intersection of supporting structure	Fixed	
Securing on supporting structure with connection to its framing	Fixed	
Securing on supporting structure without connection to its framing	Simply supported	

Securing on intercostal longitudinal	Free end	
--------------------------------------	----------	---

3.10.2.3 Side grillage structure where longitudinal framing is used.

3.10.2.3.1 A longitudinally framed side grillage structure is permitted which consists of longitudinals and web frames. Intercostal additional frames may be fitted between deep frames (refer to **3.10.2.3.3**).

In a double-side structure, the functions of deep frames are taken over by vertical diaphragms. Where a double-side structure includes horizontal diaphragms, they are considered to be platforms, and the requirements of **3.10.2.4** and **3.10.4.9** for platforms apply to them. Longitudinal framing system is not recommended for icebreakers and **Ice5** ÷ **Ice6** ice class ships.

3.10.2.3.2 Longitudinals which are intercostal in way of plate structures (refer to **3.10.2.4**) shall be secured with brackets on both sides of the plate structure, and the webs of the longitudinals shall be welded to the plate structure.

3.10.2.3.3 In icebreakers and **Ice4** – **Ice6** ice class ships where the spacing of frames is greater than 2 m, additional frames shall be fitted.

The end fixation method shall be the same as in the case of intermediate frames of **Ice1** ÷ **Ice3** ice class ships with transverse main framing in accordance with **3.10.2.1.3**, irrespective of the ice class.

3.10.2.4 Plate structures.

3.10.2.4.1 By plate structures, the sections of deck, platform and double bottom plating, of transverse bulkhead plating, deep frame plates, stringers of side and bottom, centre-plane girder, solid and lightened plate floors and bilge brackets which adjoin the shell plating are meant.

3.10.2.4.2 For hull members mentioned under **3.10.2.4.1**, the areas to be covered by the requirements for plate structures shall be established as follows:

fore peak and after peak bulkheads of icebreakers and **Ice5** and **Ice6** - ice class ships throughout their breadth;

for ships of other ice class, on a breadth of 1,2 m from the shell plating;

other bulkheads in regions **I** and **II** of ice-breakers and **Ice4** ÷ **Ice6**, ice class ships, decks and platforms of icebreakers and **Ice4** ÷ **Ice6** ice class ships, on a breadth of 1,2 m from the shell plating;

other hull members - on a breadth of 0,6 m from the shell plating.

3.10.2.4.3 In the areas of plate structures mentioned under **3.10.2.4.2**, corrugated structures with corrugations arranged along the shell plating (i.e. vertical corrugations on transverse bulkheads and longitudinal corrugations on decks or platforms) are not permitted.

3.10.2.4.4 The plate structures of icebreakers and ships of ice classes **Ice5** and **Ice6**, including those located inside the bulb, as well as plate structures of region **I** of **Ice4** ice class ships shall be strengthened with stiffeners fitted approximately normal to the shell plating. The stiffeners shall be spaced not farther apart than stipulated in Table 3.10.2.4.4.

The plate structures of **Ice1**, **Ice2**, **Ice3**, **Ice4** (except region **I**) ice class ships may be strengthened with stiffeners fitted approximately parallel to the shell plating.

Table 3.10.2.4.4



Orientation of main framing fitted at shell plating	Maximum spacing of stiffeners	
	Icebreakers Ice5 (region I), Ice6 ice class ships	Ice5 (except region I), Ice4 (region I) ice class ships
Main framing lies across a plate structure	a , but not greater than 0,5 m	$2a$, but not greater than 1,0 m
Main framing lies parallel to a plate structure	0,6	0,8 m
<i>Note.</i> a – is the spacing of main framing girder, as measured on the shell plating		

3.10.2.4.5 The intersections of plate structures with main framing shall be executed in accordance with Table 3.10.2.4.5.

The stiffeners by which the plate structure is strengthened and which lie on the same plane as the main framing girders shall be secured to the above girders.

Other methods of attaching the webs of main framing girders to the plate structure may be applied, if found equivalent by the Register.

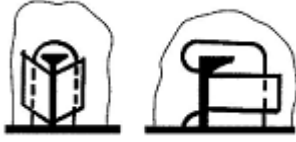
Table 3.10.2.4.5

Ice class	Sketch of structure		
			
Icebreaker4, Icebreaker3	Fore peak, after peak, region I, region II with longitudinal framing	Regions II, AIII, A ₁ III, CIII, AIV, A ₁ IV	Other regions as per Table 3.10.1.3.4
Icebreaker2, Icebreaker1	Fore peak, after peak, regions I, II with longitudinal framing	Regions I and II (except fore peak and after peak), AIII, A ₁ III, CIII	Ditto
Ice6, Ice5	Fore peak, region AI, A ₁ I, BI with longitudinal framing	Regions I (except fore peak), II, AIII, A ₁ III	Ditto
Ice4	-	Regions I, AII, A ₁ II, AIII, A ₁ III	Ditto
Ice3, Ice2, Ice1	-	-	All regions

Note. Stiffeners of plate structure and brackets stipulated in 3.10.2.4 are not shown schematically in the sketches.

3.10.2.4.6 Where main framing girders are intercostal in way of the plate structure, brackets shall be fitted on both sides of the structure on the same plane as each of the girders, and the girder webs shall be welded to the plate structure.

3.10.2.4.7 The following requirements are put forward additionally for the intersections (connections) of the plate structures of decks and platforms with main framing.

Where transverse framing is used for sides, the frames shall be attached to the beams with brackets. In **Ice5** (region I only), **Ice6** ice class ships, the girders shall be fitted on the same plane as each of the frames (refer also to Table 3.10.2.4.4).

In **Ice5** (region I only) and **Ice4** (region I) ice class ships, the frame on whose plane no beam is fitted shall be secured to the plate structure with brackets which shall terminate on the intercostal stiffener.

Where longitudinal framing is used for sides, the beams shall be attached to the shell plating with brackets reaching as far as the nearest side longitudinal.

3.10.2.4.8 The distance from the edge of opening or manhole to the shell plating shall not be less than 0,5 m in a plate structure. For openings during installation of ship systems, the distance specified may be reduced provided the structures are efficiently stiffened. The distance from the edge of opening or manhole in a plate structure to the edge of opening for the passage of a girder through the plate structure shall not be less than the height of that girder.

3.10.2.5 Fore peak and after peak structure.

3.10.2.5.1 A longitudinal bulkhead welded to the stem or sternframe shall be fitted on the centreline of the ship in the fore peak and after peak of icebreakers and the lower ends of all frames shall be connected by floors or brackets.

In the fore peak of **Ice4** ÷ **Ice6** ice class ships with bulbous bows, a longitudinal bulkhead shall be fitted inside the bulb.

3.10.2.5.2 In the fore peak of icebreakers and **Ice5** and **Ice6** ice class ships, platforms with lightening holes shall be fitted instead of stringers and panting beams (refer to 2.8.2.3), the distance between platforms measured along a chord at side, shall not exceed 2,0 m. This structure is recommended for **Ice4** ice class ships as well.

In **Ice5** ÷ **Ice6** ice class ships with bulbous bows, the specified distance shall not exceed 1,5 m. In this case, the stringer span inside the bulb shall not be more than 3 m.

3.10.2.5.3 In the after peak of icebreakers and **Ice5**, **Ice6** ice class ships (refer to 2.8.2.10), side stringers and panting beams shall be fitted so that the distance between the stringers as measured along a chord at side, would not be greater than 2,0 m.

The dimensions of stringer webs shall not be less than determined by the formulae:

$$\text{height } h = 5L + 400 \text{ mm};$$

$$\text{thickness } s = 0,05L + 7 \text{ mm.}$$

Platforms with lightening holes are recommended instead of panting beams and stringers.

3.10.2.5.4 In icebreakers and **Ice6** ice class ships, the side stringers in the fore peak and after peak shall generally be a continuation of those fitted in the regions **A** and **C** (refer to **3.10.2.1.4**).

3.10.2.5.5 In the case of **Ice4** ice class ships, the area and inertia moment of panting beams shall be increased by 25 % as compared to those required by **2.9.4**.

The dimensions of stringer webs shall not be less than given by the formulae:

$$\text{height } h = 3L + 400 \text{ mm};$$

$$\text{thickness } s = 0,04L + 6,5 \text{ mm.}$$

3.10.2.5.6 In the fore peak and after peak, the free edges of side stringers shall be stiffened with face plates having a thickness not less than the web thickness and a width not less than ten thicknesses. The interconnections of frames with side stringers shall be in accordance with Table 3.10.2.4.5, and brackets shall be carried to the face plates of the stringers.

3.10.2.6 Stem and sternframe construction.

3.10.2.6.1 Icebreakers and ice class ships shall have a solid section stem made of steel.

3.10.2.6.2 A combined stem with bar welded thereto (Fig. 3.10.2.6.2-1, *a*), or a plate stem (Fig. 3.10.2.6.2-1, *b*) may be used.

Combined or plate stem structures shall be welded with full penetration in compliance with the requirements of Part XIV "Welding".

For ships of less than 150 m in length with a sharp-lined bow, the stem shown in Fig. 3.10.2.6.2-2 may be used (the value of *s* shall be determined by Formula (3.10.4.10.1-3)).

For ships with ice class **Ice1** ÷ **Ice4** combined or plate sternframes may be used.

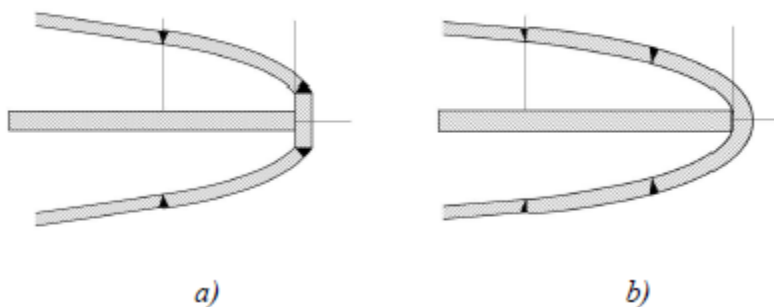

Fig. 3.10.2.6.2-1 Examples of combined (a) and plate (b) stems

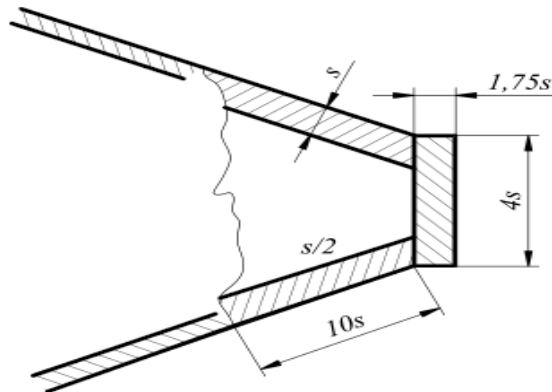

Fig. 3.10.2.6.2-2

3.10.2.6.3 For **Ice1** ÷ **Ice6** ice class ships, the stem shall, where practicable, be strengthened by a centre line web having its section depth equal to h_v at least (refer to Table 3.10.4.10.1) with a face plate along its free edge or a longitudinal bulkhead fitted on the ship centreline, on the entire stem length from the keel plate to the nearest deck or platform situated above the level H_1 referred to in **3.10.4.10** and in Table 3.10.4.10.1. The thickness of this plate shall not be less than that of the brackets with which the stem is strengthened (refer to **3.10.2.6.4**).

In icebreakers a longitudinal bulkhead may be substituted for the centre line web.

3.10.2.6.4 Within the vertical extent defined in 3.10.2.6.3, the stem shall be strengthened by horizontal webs at least 0,6 m in depth and spaced not more than 0,6 m apart. The webs shall be carried to the nearest frames and connected thereto. Where in line with side stringers, the webs shall be attached to them. In stems of combined or plate type, the webs shall be extended beyond the welded butts of the stem and shell plating. Above the deck or platform located, by the value of H_1 at least (refer to **3.10.4.10.1** and Table 3.10.4.10.1), higher than the upper boundary of region I, the spacing of horizontal webs may gradually increase to 1,2 m in icebreakers and **Ice6**, **Ice5** and **Ice4** ice class ships, and to 1,5 m in ships of other ice classes. The web thickness shall be adopted not less than half the stem plate thickness

The side stringers of the fore peak shall be connected to the webs fitted in line with them.

In case of a full bow, vertical stiffeners may be required additionally to be fitted to the stem plates.

3.10.2.6.5 Where the stern frame has an appendage (ice knife), the clearance between the latter and the rudder plate shall not exceed 100 mm. The appendage shall be reliably connected to the stern frame. Securing the appendage to plate structures is not permitted.

3.10.2.6.6. In icebreakers, the lower edge of solepiece shall be constructed with a slope of 1:8 beginning from the propeller post.

3.10.2.7 Bottom structure.

3.10.2.7.1 In icebreakers and **Ice5** and **Ice6** ice class ships, double bottom shall be provided between the fore peak bulkhead and the after peak bulkhead.

3.10.2.7.2 In icebreakers, provision shall be made for solid floors at each main frame.

3.10.2.7.3 In regions of ice strengthening in way of bottom, as established in accordance with Table 3.10.1.3.4, bracket floors are not permitted.

3.10.2.7.4 In icebreakers the centreline girder height shall not be less than determined by the formula

$$h = \varphi(9L + 800), \quad (3.10.2.7.4)$$

where: $\varphi = 1$ – for icebreakers.

3.10.2.7.5 In icebreakers the spacing of bottom stringers shall not exceed 3,0 m.

3.10.2.8 Special requirements.

3.10.2.8.1 In icebreakers, double side structure shall generally be provided between the fore peak bulkhead and the after peak bulkhead.

3.10.2.8.2 Where the web plate of a girder or a plate structure is considerably inclined to the shell plating (the angle between them being less than 50°), the framing normal to the shell plating or an inclined plate

structure is recommended (Fig. 3.10.2.8.3). Otherwise, special measures shall be taken to prevent the collapsing of the girder or the bulging of the plate structure.

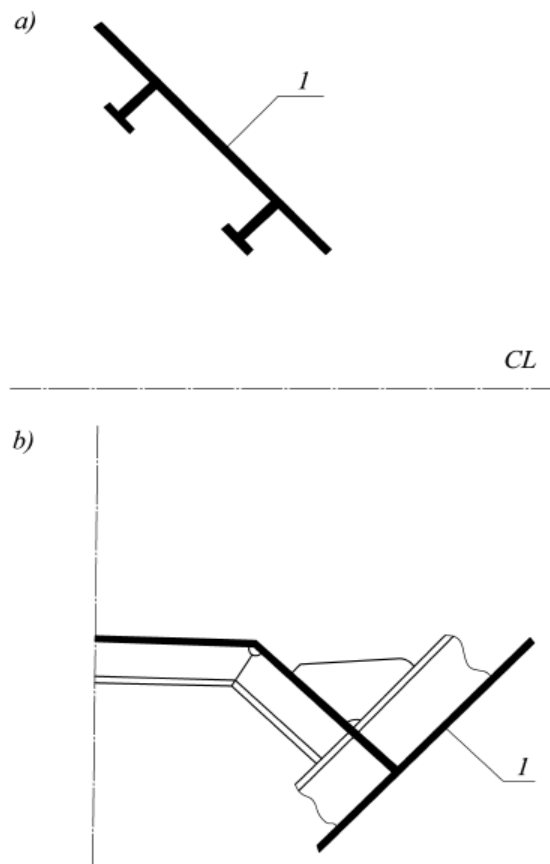

Fig. 3.10.2.8.2

a – framing normal to shell plating; *b* – inclined plate structure; *l* – shell plating

3.10.3 Ice load.

3.10.3.1 *Ice load* is the approximate design load acting on the hull due to ice forces, by which the level of requirements for scantlings is determined based on the ice class mark, hull shape and ship displacement.

The ice load depends on three parameters:

p - ice pressure being a characteristic of the maximum pressure in the area of dynamic contact between the hull and ice, in kPa;

b - vertical distribution of ice pressure characterizing the maximum transverse dimension of the dynamic contact area between the hull and ice, in m;

l^p - horizontal distribution of ice pressure characterizing the maximum longitudinal dimension of the dynamic contact area between the hull and ice, in m.

The ice load is solely intended to determine the scantlings of structural components of ice strengthening on the basis of the formulae included in this Chapter.

Using the ice load parameters for strength estimation on the basis of other procedures and programs is not permitted without prior consent of the Register.

The ice load parameters, determined in compliance with 3.10.3.2 ÷ 3.10.3.7, are applicable only to ice class ships and icebreakers with a hull shape that meets the requirements of 3.10.1.2.2 i 3.10.1.2.3.

At the fore part with slope of design ice waterline $\alpha > 3^\circ$, for ice class ships with bulbous bows, and when $\beta \leq 5^\circ$, the ice load parameters shall be determined in compliance with 3.10.3.8.

3.10.3.2 For ice class ships, the ice pressure, in kPa, shall be determined by the following formulae:

.1 in region AI

$$p_{AI} = 2500a_1v_m(\Delta/1000)^{1/6}, \quad (3.10.3.2.1)$$

where: a_1 – factor to be taken from Table 3.10.3.2.1 based on the ice class;

Δ – displacement to summer load waterline, in t;

v_m – value of the shape factor v , which is the maximum one for the region, as determined at sections within $x = 0; 0,025L; 0,05L; 0,075L; 0,1L$, etc. from the forward perpendicular (as far as Ice1, Ice2 and Ice3 ice class ships are concerned, design sections where $x \leq 0,58b$, shall only be considered; for b , refer to Fig. 3.10.1.3.2) at the design ice waterline.

The value shall be determined by the following formulae:

for ships and icebreakers with the hull shape compliant with the provisions of **3.10.1.2.2** and **3.10.1.2.3**

$$v = [0,278 + (0,18x/L)] \cdot (\alpha^2/\beta)^{1/4} \text{ at } x/L \leq 0,25;$$

$$v = [0,343 - (0,08x/L)] \cdot (\alpha^2/\beta)^{1/4} \text{ at } x/L > 0,25;$$

for other ships and icebreakers

$$v = f_v(0,9 + 0,3x/L + 0,005\alpha - 0,0015\beta'),$$

where: L – length at design ice waterline;

x – distance between the considered section and the forward perpendicular, in m;

α – angle of design waterline inclination which shall be measured in accordance with Figs. 3.10.1.2-1 and 3.10.1.2-3 (where $x = 0$), in deg.;

β – angle of frame inclination at design ice waterline on the considered section which shall be measured in accordance with Fig. 3.10.1.2.1-2, in deg.; where the frame is concave, in case of **Ice4** ÷ **Ice6** ice class ships, β shall be chosen as a minimum angle, which is measured at service waterlines;

$\beta' = \arctg(\tg\beta \cdot \cos\alpha) =$ – side inclination angle with regard to normal, deg;

$$f_v = [(\sin\alpha \cdot \cos\beta')^{0,54}] / [(\cos\beta')^{0,17} \cdot (\sin\beta')^{0,25}].$$

If $\alpha > 0$ and $\beta = 0$ in a section under consideration of **Ice1** ÷ **Ice3** ice class ships, it shall be considered that $v = 0,72$ in this section.

If the angle of α is less than 3° in a section of **Ice1** ÷ **Ice5** ice class ships, such a section may be omitted when calculating v_m ;

Table 3.10.3.2.1

Factor	Ice class					
	Ice1	Ice2	Ice3	Ice4	Ice5	Ice6
a_1	0,36	0,49	0,61	0,79	1,15	1,89
a_2	-	-	-	0,8	1,17	1,92
a_3	-	0,22	0,33	0,5	0,78	1,2
a_4	-	0,5	0,63	0,75	0,87	1

.2 in region **A₁I**

$$p_{A1I} = 2500a_2v_m(\Delta/1000)^{1/6}, \quad (3.10.3.2.2)$$

where: a_2 – factor to be taken from Table 3.10.3.2.1 based on the ice class;

v_m – shall be determined by the method described in **3.10.3.2.1**;

for Δ – refer to **3.10.3.2.1**;

.3 in region **BI**

$$p_{BI} = 1200a_3(\Delta/1000)^{1/6}, \quad (3.10.3.2.3)$$

where: a_3 – factor to be taken from Table 3.10.3.2.1 based on the ice class;

for Δ – refer to **3.10.3.2.1**;

.4 in region **CI** of **Ice2** – **Ice6** ice class ships

$$p_{CI} = a_4p_{BI}, \quad (3.10.3.2.4-1)$$

where: a_4 – factor to be taken from Table 3.10.3.2.1 based on the ice class;
for p_{BI} – refer to **3.10.3.2.3**.

.5 in regions **II**, **III** and **IV**, the ice pressure is determined as a part of the ice pressure in region **I** at the appropriate section of the ship length:

$$p_{kl} = a_{kl} \cdot p_{kl}, \quad (3.10.3.2.5)$$

where: $k = \mathbf{A}, \mathbf{A}_1, \mathbf{B}, \mathbf{C}$;

$l = \mathbf{II}, \mathbf{III}, \mathbf{IV}$;

a_{kl} – factor to be taken from Table 3.10.3.2.5.

Table 3.10.3.2.5

Ice class	Region lengthwise								
	forward and intermediate regions (A and A ₁)			midship region (B)			aft region (C)		
	Region vertically								
	II	III	IV	II	III	IV	II	III	IV
Ice3	0,4	-	-	-	-	-	-	-	-
Ice4	0,5	0,4	0,35	0,4	-	-	-	-	-
Ice5	0,65	0,65	0,45	0,5	0,4	-	0,5	-	-
Ice6	0,65	0,65	0,5	0,5	0,45	-	0,5	0,35	0,15

3.10.3.3 The vertical distribution of ice pressure, in m, shall be determined by the following formulae:

.1 in regions **AI**, **AII**, **AIII**, **AIV**

$$b_A = C_1 k_{\Delta} u_m, \quad (3.10.3.3.1)$$

where: C_1 – factor to be taken from Table 3.10.3.3.1 based on the ice class;

$k_{\Delta} = (\Delta/1000)^{1/3}$, but not greater than 3,5;

Table 3.10.3.3.1

Factor	Ice class					
	Ice1	Ice2	Ice3	Ice4	Ice5	Ice6
C_1	0,38	0,42	0,44	0,49	0,6	0,62
C_2	-	-	-	0,55	0,7	0,73
C_3	-	0,27	0,3	0,34	0,4	0,47

For Δ - refer to **3.10.3.2.1**;

u_m - maximum value of the shape factor u for the region, as determined at sections within $x = 0; 0,025L; 0,05L; 0,075L; 0,1L$, etc. from forward perpendicular (as far as Ice1, Ice2 and Ice3 ice class ships are concerned, sections where $x \leq 0,58b$, shall only be considered; for b , refer to Fig. 3.10.1.3.2) at the design ice waterline.

The value shall be determined by the following formulae:

for ships and icebreakers with the hull shape compliant with the provisions of **3.10.1.2.2** i **3.10.1.2.3**

$$u = k_B \cdot [0,635 + (0,61x/L)] \cdot \sqrt{\alpha/\beta} \quad \text{at } x/L \leq 0,25;$$

$$u = k_B \cdot [0,862 - (0,3x/L)] \cdot \sqrt{\alpha/\beta} \quad \text{at } x/L > 0,25;$$

for other ships and icebreakers

$$u = f_u(0,72 + x/L + 0,001\alpha - 0,013x\beta'/L),$$

where for $L, x, \alpha, \beta, \beta'$ - refer to **3.10.3.2.1**;

$$k_B = 1 \quad \text{at } \beta \geq 7^\circ;$$

$$k_B = 1,15 - 0,15 \beta/7 \quad \text{at } \beta < 7^\circ;$$

$$f_u = [(\sin\alpha \cdot \cos\beta')^{0,58}] / [(\cos\beta')^{0,33} \cdot (\sin\beta')^{0,5}].$$

If $\alpha > 0$ and $\beta = 0$, in a section of **Ice1** ÷ **Ice3** ice class ships, it shall be considered that $u=0,92$ for this section.

If the angle α is less than 3° in a section of **Ice1** ÷ **Ice5** ice class ships, such a section may be omitted when calculating u_m ;

.2 in regions **A_II**, **A_III**, **A_IIII**, **A_IIV**

$$b_{A1} = C_2 k_{\Delta} u_m, \text{ but not greater than } 1,25 b_A p_{A1} / p_{A11}, \quad (3.10.3.3.2-1)$$

where: C_2 – factor to be taken from Table 3.10.3.3.1 based on the ice class;

for k_{Δ} - refer to **3.10.3.3.1**;

u_m - shall be determined by the procedure described in **3.10.3.3.1**;

for b_A – refer to **3.10.3.3.1**;

for p_{A1} - refer to **3.10.3.2.1**;

for p_{A11} – refer to **3.10.3.2.2**.

In any case, the vertical distribution b_{A1} shall be not less than that determined by the formula:

$$b_{A1} = p_{B1} b_B / p_{A11}, \quad (3.10.3.3.2-2)$$

where for p_{A11} – refer to **3.10.3.2.2**;

for p_{B1} - refer to **3.10.3.2.3**;

for b_B – refer to **3.10.3.3.3**;

.3 in regions **BI**, **BII**, **BIII**, **BIV**

$$b_B = C_3 C_4 k_{\Delta}, \quad (3.10.3.3.3)$$

де: C_3 - factor to be taken from Table 3.10.3.3.1 based on the ice class;

C_4 - = factor to be taken from Table 3.10.3.3.3 based on the minimal side inclination angle with regard to normal;

for k_{Δ} - refer to **3.10.3.3.1**;

Table 3.10.3.3.3

Factor	Angle of side slope amidships, in deg.						
	≤ 6	8	10	12	14	16	18
C_4	1,0	0,81	0,68	0,54	0,52	0,47	0,44

.4 in regions **CI**, **CII**, **CIII**, **CIV**

$$b_C = 0,8 b_B - \text{for } \mathbf{Ice2} \div \mathbf{Ice6} \text{ ice class ships};$$

where for b_B – refer to **3.10.3.3.3**.

3.10.3.4 Horizontal distribution of ice pressure, in m, shall be determined by the following formulae:

.1 in regions **AI**, **AII**, **AIII**, **AIV**

$$l^H_A = 11,3 \sqrt{b_A \sin \beta_m^A}, \text{ but not less than } 3,5 \sqrt{k_{\Delta}}, \quad (3.10.3.4.1)$$

where for b_A , k_{Δ} - refer to **3.10.3.3.1**;

β_m^A - =angle β' in the design section of region A for which the value of the u parameter is maximum (refer to **3.10.3.3.1**);

for β' - refer to **3.10.3.2.1**;

.2 in regions **A_II**, **A_III**, **A_IIII**, **A_IIV**

$$l^H_{A1} = 11,3 \sqrt{b_{A1} \sin \beta_{A1}^m}, \text{ but not less than } 3 \sqrt{k_{\Delta}}, \quad (3.10.3.4.2)$$

where for b_{A1} – refer to **3.10.3.3.2**;

β^{A1} – angle β' in the design section of region **A1** for which the value of the u parameter is maximum (refer to **3.10.3.3.1**);

for β' – refer to **3.10.3.2.1**;

for k_{Δ} – refer to **3.10.3.3.1**;

.3 in regions **BI, BII, BIII, BIV**

$$l^H_B = 6b_B, \text{ but not less than } \sqrt[3]{k_{\Delta}}, \quad (3.10.3.4.3)$$

where for b_B – refer to **3.10.3.3.3**;

for k_{Δ} – refer to **3.10.3.3.1**;

.4 in regions **CI, CII, CIII, CIV**

$$l^H_C = 6b_C, \text{ but not less than } \sqrt[3]{k_{\Delta}}, \quad (3.10.3.4.4)$$

where for b_C – refer to **3.10.3.3.4**;

for k_{Δ} – refer to **3.10.3.3.1**.

3.10.3.5 For icebreakers, the ice pressure shall be determined by the following formulae:

.1 in region **AI**

$$p_{AI} = k_p \cdot p^{0}_{AI}, \quad (3.10.3.5.1)$$

where: p^{0}_{AI} – ice pressure in region **AI**, to be determined in accordance with **3.10.3.2.1** as in the case of a ship whose ice class number coincides with the ice class number of the icebreaker;

$k_p = 1$ where $N_{\Sigma} \leq N_0$;

$k_p = (N_{\Sigma} / N_0)$ where $N_{\Sigma} > N_0$;

N_{Σ} – propeller shaft output, in MW;

N_0 – shall be taken from Table 3.10.3.5.1;

Table 3.10.3.5.1

Ice class of icebreaker	N_0 , in MW
Icebreaker1	10
Icebreaker2	20
Icebreaker3	40
Icebreaker4	60

.2 in regions **A1I, BI i CI**

$$p_{kI} = a_k p_{AI}, \quad (3.10.3.5.2)$$

where for p_{AI} – refer to **3.10.3.5.1**;

a_k – factor to be taken from Table 3.10.3.5.2 based on the region of the ship length and the ice class of icebreaker;

$k = \mathbf{A1, B, C}$;

Table 3.10.3.5.1

Region	Ice class of icebreaker			
	Icebreaker1	Icebreaker2	Icebreaker3	Icebreaker4
A1I	0,65	0,75	0,85	0,85
BI	0,6	0,65	0,7	0,75
CI	0,75	0,75	0,75	0,75

.3 in regions **II, III** and **IV**, the ice pressure shall be determined as a part of the ice pressure in region **I** for the appropriate region of ship length:

$$p_{mn} = a_{mn} \cdot p_{mI}, \quad (3.10.3.5.3)$$

where: $m = \mathbf{A, A1, B, C}$;

$n = \mathbf{II, III, IV}$;

a_{mn} – factor to be taken from Table 3.10.3.5.3.

Table 3.10.3.5.3

Factor	Region vertically and region lengthwise											
	AII	AIII	AIV	A₁II	A₁III	A₁IV	BII	BIII	BIV	CII	CIII	CIV
a_{mn}	0,7	0,65	0,5	0,6	0,55	0,45	0,55	0,45	0,35	0,55	0,4	0,3

3.10.3.6 As far as icebreakers are concerned, the vertical distribution of ice pressure shall be adopted equal for all regions and shall be determined in accordance with **3.10.3.3.1**, i.e. as for the forward region of the ship whose ice class number coincides with the ice class number of the icebreaker. When determining u_m the values of u shall be calculated for those sections only which are included in the forward region of ice strengthening of the icebreaker.

3.10.3.7 As far as icebreakers are concerned, the horizontal distribution of ice pressure shall be adopted equal for all regions and shall be determined in accordance with **3.10.3.4.1**, i.e. as for the forward region of the ship whose ice class number coincides with the ice class number of the icebreaker.

When determining β_m only those sections shall be considered which are included in the forward region of ice strengthening of the icebreaker.

3.10.3.8 Ice load parameters for the bow areas with the vertical side ($\beta < 5$) in the region of alternating draughts, or bulbous bows.

3.10.3.8.1 For ships of ice classes, the ice pressure, in kPa, shall be determined by the following formulae: for ships of ice classes **Ice1**, **Ice2** i **Ice3**

$$p_{AI} = 0,985 \cdot p_{ref}^i \cdot v_m \cdot (\Delta/1000)^{0,0132}, \quad 1 \leq \Delta \leq 5 \text{ thousand t};$$

$$p_{AI} = 0,976 \cdot p_{ref}^i \cdot v_m \cdot (\Delta/1000)^{0,0052}, \quad 5 < \Delta \leq 200 \text{ thousand t};$$

for ice classes **Ice4**, **Ice5** i **Ice6**

$$p_{AI} = 0,790 \cdot p_{ref}^i \cdot v_m \cdot (\Delta/1000)^{0,0614},$$

where: p_{ref}^i – factor to be taken from Table 3.10.3.8.1-1 based on the ice class;

v_m – maximum value of the shape factor v to be determined in bow area sections with the vertical side at design waterline by the formula:

$$v[(x/L), \alpha] = b^{v_0} + b^{v_1} \cdot (x/L) + b^{v_2} \cdot \alpha + b^{v_{11}} \cdot (x/L)^2 + b^{v_{22}} \cdot \alpha^2 + b^{v_{12}} \cdot (x/L) \cdot \alpha;$$

b^{v_i} – factors to be taken from Table 3.10.3.8.1-2;

Δ - displacement at design ice waterline, t.

For ships with bulbous bows, when determining the design loads on the bulb structure, v_m is determined at the ballast waterline, if it passes through the bulb, otherwise - at the waterline, where inclination angle of the bulb plating $\beta = 0 \div 5^\circ$.

Table 3.10.3.8.1-1

	1 ≤ Δ ≤ 5 thousand t			5 < Δ ≤ 200 thousand t			Ice4	Ice5	Ice6
	Ice1	Ice2	Ice3	Ice1	Ice2	Ice3			
p_{ref}^i	1100	1430	1760	1120	1460	1810	3620	5910	10360
b^{α}	-	-	-	-	-	-	1,5	2,0	3,7
b_{ref}^i	0,65	0,80	1,00	0,65	0,80	1,00	-	-	-
l_{ref}^i	3,66	4,33	4,27	12,05	14,22	13,94	4,55	4,52	4,39

Table 3.10.3.8.1-2

b^{v_i}	1 ≤ Δ ≤ 5 thousand t			5 < Δ ≤ 200 thousand t			Ice4	Ice5	Ice6
	Ice1	Ice2	Ice3	Ice1	Ice2	Ice3			
b^{v_0}	0,769	0,747	0,714	1,015	1,020	1,008	0,728	0,754	0,790
b^{v_1}	-4,004	-3,924	-3,373	-5,829	-5,975	-5,679	-3,758	-4,790	-6,170

b^u_2	0,039	0,040	0,040	0,035	0,036	0,037	0,021	0,021	0,020
b^u_{11}	11,17	11,26	9,75	14,57	15,06	13,46	20,50	24,90	32,21
b^u_{22}	-0,0003	-0,0003	-0,0003	-0,0003	-0,0003	-0,0003	-0,0003	-0,0002	-0,0002
b^u_{12}	-0,0490	-0,0517	-0,0642	-0,0393	-0,0404	-0,0481	0,0688	0,0917	0,1188

3.10.3.8.2 Vertical distribution of ice pressure, in m, for ice class ships **Ice1**, **Ice2**, **Ice3** shall be determined by the formula:

$b_A = b^i_{ref} \cdot u_{b-m}$, but not exceeding the distance between the side stringers (for structures inside the bulb - platforms or webs installed according to **3.10.2.6.4**),

where: b^i_{ref} – the factor taken as per Table 3.10.3.8.1-1 depending on the ice class;

u_{b-m} – = maximum value of the shape factor u_b , to be determined in sections of bow area with the vertical side at design ice waterline by the formula

$$u_b(x/L) = b^u_0 + b^u_1 \cdot (x/L) + b^u_{11} \cdot (x/L)^2;$$

b^u_i – = factors to be taken from Table 3.10.3.8.3.

Vertical distribution of ice pressure, in m, for ships of ice classes **Ice4**, **Ice5** and **Ice6** shall be determined by the formula

$b_A = b^{11}$, but not exceeding the distance between the side stringers (for structures inside the bulb - platforms or webs installed according to **3.10.2.6.4**),

where: b^{11} – is taken from Table 3.10.3.8.1-1 based on the ice class.

Table 3.10.3.8.2

b^u_i	Ice1	Ice2	Ice3
b^u_0	2,283	2,283	2,146
b^u_1	-11,88	-11,85	-10,28
b^u_{11}	22,14	22,02	17,60

3.10.3.8.3 Horizontal distribution of ice pressure, in m, shall be determined by the following formulae: for ships of ice classes **Ice1**, **Ice2** and **Ice3**:

$$l_A = 0,748 \cdot l^i_{ref} \cdot u_{l-m} \cdot (\Delta/1000)^{0,3065}, \quad 1 \leq \Delta \leq 5 \text{ thousand t};$$

$$l_A = 0,218 \cdot l^i_{ref} \cdot u_{l-m} \cdot (\Delta/1000)^{0,3311}, \quad 5 \leq \Delta \leq 200 \text{ thousand t};$$

for ships of ice classes **Ice4**, **Ice5** i **Ice6**:

$$l_A = 0,337 \cdot l^i_{ref} \cdot u_{l-m} \cdot (\Delta/1000)^{0,2906},$$

where: l^i_{ref} – = factor to be taken from Table 3.10.3.8.1-1 based on the ice class;

u_{l-m} – maximum value of the shape factor u_l , to be determined in sections of bow area with the vertical side at design waterline by the formula

$$u_l[(x/L), \alpha] = b^u_0 + b^u_1 \cdot (x/L) + b^u_2 \cdot \alpha + b^u_{11} \cdot (x/L)^2 + b^u_{22} \cdot \alpha^2 + b^u_{12} \cdot (x/L) \cdot \alpha;$$

b^u_i – factors to be taken from Table 3.10.3.8.3.

Table 3.10.3.8.3

b^u_i	$1 \leq \Delta \leq 5$ thousand t			$5 < \Delta \leq 200$ thousand t			Ice4	Ice5	Ice6
	Ice1	Ice2	Ice3	Ice1	Ice2	Ice3			
b^u_0	0,186	0,171	0,166	0,167	0,155	0,139	0,307	0,302	0,324
b^u_1	-3,339	-3,319	-2,377	-3,297	-3,318	-2,607	0,205	0,325	0,294
b^u_2	0,0241	0,0227	0,0184	0,0231	0,0216	0,0222	0,0370	0,0375	0,0363

b_{11}^u	17,2	17,6	18,4	17,4	17,9	15,02	2,37	1,78	1,17
b_{22}^u	-0,0003	-0,0003	-0,0002	-0,0003	-0,0003	-0,0003	-0,0002	-0,0003	-0,0002
b_{12}^u	0,148	0,159	0,110	0,153	0,165	0,152	0,031	0,030	0,030

3.10.3.8.4 For ships of ice classes **Ice1**, **Ice2** i **Ice3**, with stretched area of vertical side (from the forward perpendicular to parallel midship body), intermediate regions of ice strengthening may be added at the length of bow. In this case, the values of hull shape factors v_m, u_{b-m}, u_{l-m} shall be taken equal to the maximum value of the relevant factors determined for each intermediate regions at designed ice waterline.

3.10.3.8.5 For ships of ice classes **Ice4**, **Ice5** i **Ice6** with bulbous bows and extended bow area at design waterline, an intermediate region of ice strengthening inside the region A may be added, in addition to the requirements of **3.10.1.3.1**. In this case, the values of hull shape factors v_m, u_{b-m}, u_{l-m} shall be taken equal to the maximum value of the relevant factors determined for each intermediate region inside the A region at design waterline.

3.10.4 Scantlings of ice-strengthening structures.

3.10.4.1 Shell plating.

In regions of ice strengthening, the shell plating thickness s_{sp} , in mm, shall not be less than determined by the formula

$$s_{sp} = s_{sp0} + \Delta s_{sp0}, \quad (3.10.4.1)$$

$$\text{where: } s_{sp0} = 15,8a_0\sqrt{p}/R_{eH};$$

$$\Delta s_{sp0} = 0,75Tu;$$

$$a_0 = a/(1 + 0,5a/c);$$

p - ice pressure in the region under consideration according to **3.10.3.2** or **3.10.3.5**, in kPa;

$c = b$ - where the grillage is transversely framed in the region under consideration. In this case, c shall not be greater than the spacing of intercostal stringers or the distance between plate structures;

$c = l$ - where the grillage is longitudinally framed in the region under consideration;

b - vertical distribution of ice pressure in the region under consideration according to **3.10.3.3** or **3.10.3.6**, in m;

l - distance between adjacent transverse members, in m;

a - spacing of shell plating stiffeners, in m;

T - planned ship life, in years;

u - annual reduction of shell plating as a result of corrosion wear and abrasion, in mm per year, to be taken from Table 3.10.4.1 of this Part.

Table 3.10.4.1

Ice class	u , in mm per year	
	Region lengthwise	
	forward and intermediate (A and A ₁)	midship and after (B and C)
Ice1	0,17	In accordance with 1.1.5.2
Ice2	0,22	
Ice3	0,25	
Ice4	0,3	0,2
Ice5, Ice6	0,35	0,24
Icebreaker1	0,4	0,3
Icebreaker2	0,5	0,35
Icebreaker3	0,6	0,4
Icebreaker4	0,7	0,4

3.10.4.2 Procedure for determining the required and actual geometrical characteristics of girder structures.

3.10.4.2.1 The formulae, as given in **3.10.4.3** ÷ **3.10.4.8**, for determining the required geometrical characteristics of girder structure cross sections, such as the ultimate section modulus W and the web area A , are based on the ultimate strength criterion.

The recommendations of **3.10.4.2.2** ÷ **3.10.4.2.6** shall preferably be considered when determining the values of W and A .

3.10.4.2.2 The required value of the ultimate section modulus W is proportionate to the factor k which varies on the basis of the dependence between the required web area A and the actual web area A_a (adopted when choosing the section):

$$W = W_0 k; \quad k = k(\gamma); \quad \gamma = A/A_a, \quad (3.10.4.2.2-1)$$

where: W_0 - required value of W , web area margin disregarded, to be determined in accordance with **3.10.4.3.1**, **3.10.4.4.1**, **3.10.4.5.1**, **3.10.4.6.1**, **3.10.4.7.1**.

In the absence of a web area margin ($A = A_a$, $\gamma = 1$) the value of W is maximum ($k = 1$).

The increase of the actual web area as compared with the required one ($\gamma < 1$) makes it possible to reduce the value of W (assuming $\gamma = 0,9 \div 0,8$; $k = 0,7 \div 0,63$).

Thus, the application of a flexible procedure for choosing a profile is ensured to avoid redundant margins of material with several approximations during the calculation.

By way of the first approximation, the following assumptions shall be made in Formulae (3.10.4.3-1), (3.10.4.4-1), (3.10.4.5-1), (3.10.4.6-1), (3.10.4.7-1):

$\gamma_i = 0,9$, i.e. the actual girder web area shall be at least by 10 % greater than the required one;

$$k_f = 1/(F + 0,15j) \text{ - for conventional frames;} \quad (3.10.4.2.2-2)$$

$k_i = 0,63$ - for other girder types,

where: i - girder type index (f for frame, s for stringer, wf for web frame, l for longitudinal);
for F, j - refer to **3.10.4.3.1**.

3.10.4.2.3 For grillages comprising deep frames, a procedure is implemented to take account of the redundant margins of material which emerge when choosing girder sections as a result of the actual section modulus W_a and the actual web area A_a exceeding the required values of W and A . Redundant margins are accounted for by applying the factors:

$$\gamma_i \leq 1; \quad \psi_i = (W_{\phi i}/W_{0i}) \leq k_i, \quad (3.10.4.2.3)$$

where for k_i, γ_i, W_{0i} - refer to Formula (3.10.4.2.2-1);
for i - refer to Formula (3.10.4.2.2-2).

If the actual geometrical characteristics of a conventional frame exceed the required ones ($\gamma_f < 1, \psi_f > k_f$), in a transversely framed grillage, the required geometrical characteristics of the supporting stringer and deep frame (in the case of the latter, redundant margins, if any, of the bearing stringer ($\gamma_s < 1, \psi_s > k_s$) are also considered) are lowered due to this.

Similarly, case of a longitudinally framed grillage for lowering the requirements for the deep frame where longitudinals have redundant margins ($\gamma_l < 1, \psi_l > k_l$).

3.10.4.2.4 Where the profile selection procedures in accordance with **3.10.4.2.2** and the procedures for considering the redundant margins of materials in accordance with **3.10.4.2.3** appear too complicated, a simplified calculation can be carried out, assuming

$\gamma_i = 0,9$;

$$k_f = 1/(F + 0,15j) \text{ - for conventional frames;} \quad (3.10.4.2.2-2)$$

$k_i = 0,63$ - for other types of girders;

$\psi_i = k_i$.

Precise instructions concerning the simplified calculation procedure shall be found directly in **3.10.4.3** ÷ **3.10.4.7**.

No simplified calculation is allowed if flat bar profile is used for conventional frames. The simplified calculation results in increase of girder scantinds.

Therefore, the simplified calculation is not recommended for icebreakers and **Ice4** ÷ **Ice6** ice class ships.

3.10.4.2.5 When selecting profiles, the face plate and effective flange sections whose breadth is equal to the web thickness (refer to Fig. 3.10.4.2.5) shall be included in the actual web area A_a , in cm^2 .

If there are cutouts in girder webs, they may be ignored in the case of side stringers only provided the openings are not made in the vicinity of supporting sections. The requirements for the area of frame webs (both conventional and deep frames) shall be verified on the basis of net sections.

3.10.4.2.6 To determine the actual value of the ultimate section modulus of the girders of ice strengthening structures it is recommended to use the formula

$$W_a = h(f_{sec} - 0,5f_w - C), \text{ in cm}^3, \quad (3.10.4.2.6-1)$$

where: $C = 0$, with $f_{ef} \geq f_{sec}$;

$$C = ((f_{sec} - f_{ef})^2 / (4f_w)), \text{ with } f_{ef} < f_{sec};$$

f_{sec} – girder sectional area minus effective flange of shell plating, in cm^2 ;

$f_w = 0,1[h - 0,05(t_{fp} + t_{ef})]s$, in cm^2 ;

h – section height measured from the mid-thickness of effective flange to the mid-thickness of face plate (refer to Fig. 3.10.4.2.5), in cm;

s – section web thickness, in mm;

$f_{ef} = 0,1b_{ef}t_{ef}$ – effective flange area of shell plating, in cm^2 ;

t_{fp} – effective flange thickness, in mm, of shell plating, to be adopted equal to the average shell plating thickness in way of effective flange breadth;

f_p = face plate thickness, in mm, ($t_{fp} = 1,5s$ to be adopted for bulb steel sections);

b_{ef} – effective flange breadth, in cm, to be adopted equal to:

conventional frame spacing, for conventional and deep frames where transverse framing is used; longitudinal spacing, for longitudinals where longitudinal framing is used;

1/6 of deep frame span between decks or platforms, or of frame spacing, whichever is less, for deep frames where longitudinal framing is used;

1/6 of frame spacing, for stringers where web framing is used;

half the sum of spacings of two adjacent girders of the same direction or 1/6 of girder span, whichever is less, in all other cases.

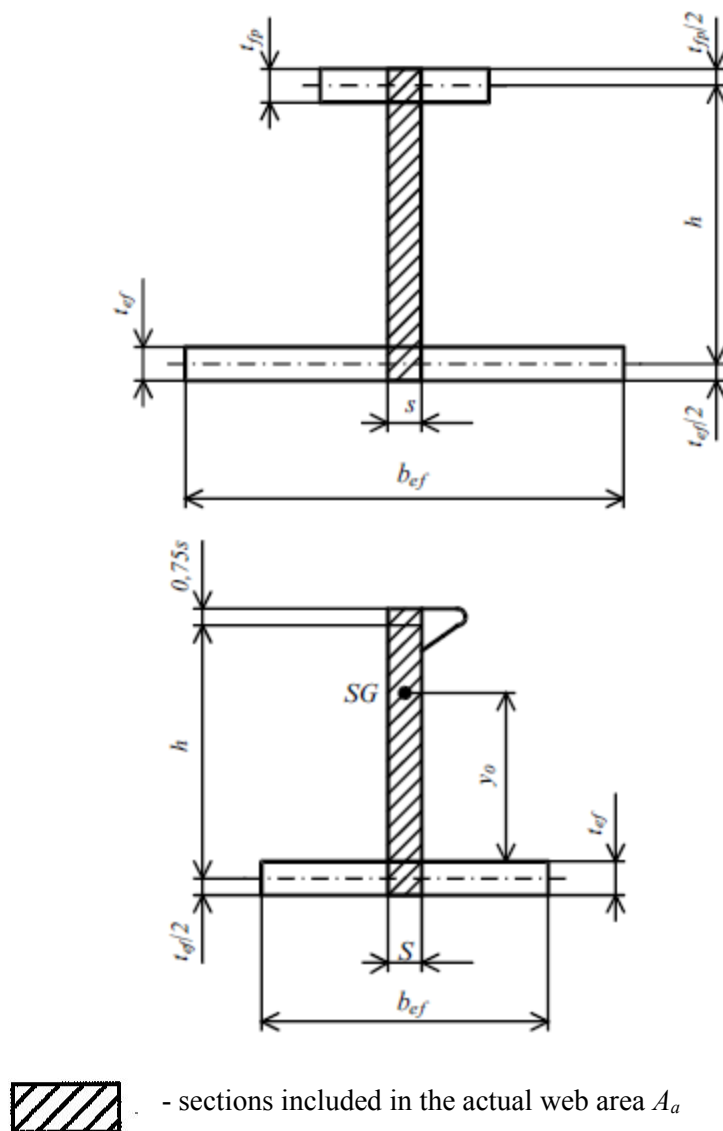

Fig. 3.10.4.2.5.

For rolled profiles where $f_{ef} \geq f_{sec}$ it may be assumed that:

$$W_a = f_{sec}(y_0 + 0,05t_{ef}), \text{ in cm}^3, \quad (3.10.4.2.6-2)$$

where: y_0 – distance between the gravity centre of the profile cross section, minus effective flange, and the shell plating, in cm (refer to Fig. 3.10.4.2.5).

3.10.4.3 Conventional frames where transverse framing is used.

The requirements of this paragraph apply to conventional frames in grillages with transverse main framing and in grillages with deep frames where transverse framing is used.

In the case of grillages with transverse main framing, the requirements shall be applied to a single span of a conventional frame which lies between the supporting sections of the frame on the upper and lower supporting structures.

In the case of grillages with deep frames, the requirements shall be applied to all the spans of a conventional frame, i.e. between the supporting sections of the upper supporting structure and the upper side stringer, between side stringers ($m - 1$ section where m is the number of side stringers), between the lower side stringer and the supporting section of the lower supporting structure.

3.10.4.3.1 The ultimate section modulus W_f , in cm^3 , of a conventional frame shall not be less than determined by the formula:

$$W_f = k_f W_{f0}, \quad (3.10.4.3.1)$$

where: $k_f = 1/[F + 0,25j \cdot \sqrt{(1 - k_s \gamma_f^2)}]$, $k_f = 1/(F + 0,15j)$ – for the case of the simplified calculation in accordance with **3.10.4.2.4**;

$F = 1$ with $k = 4$;

$F = 0,5$ with $k < 4$;

k – factor equal to:

as far as grillages with transverse main framing are concerned, refer to Table 3.10.4.3.1-1;

4 for grillages with deep frames;

Table 3.10.4.3.1-1

Parameter	Type of intermediate frame end fixation		
	both ends supported	one end supported, the other free (attached to an intercostal member)	both ends free (attached to an intercostal member)
k	4	3	2
l	Half the sum of distances between the supporting sections of two adjacent frames	Distance between the supporting sections of main frame	

j – factor equal to:

the number of fixed supporting sections of two adjacent frames, $j \leq 4$ as far as grillages with transverse main framing are concerned;

in the case of grillages with web framing, refer to Table 3.10.4.3.1-2;

Table 3.10.4.3.1-2

Position of conventional frame zone under consideration	l	j
Between side stringers	Distance between side stringers	4
Between upper (lower) supporting structure and the nearest side stringer	Half the sum of distances between supporting sections on supporting structure and the nearest side stringer for two adjacent frames	$j_0 + 2$, where $j_0 \leq 2$ – is the number of fixed supporting sections on the supporting structure for two adjacent frames

$k_s = 1$ for plate sections;

$k_s = 0,8$ in other cases;

$\gamma_f = A_f/A_a$;

for A_f – refer to **3.10.4.3.2**;

for A_a – refer to **3.10.4.3.3**;

$$W_{f0} = 250pb\alpha Y k_k E \omega_f / R_{eH};$$

p – ice pressure in the region under consideration in accordance with **3.10.3.2** or **3.10.3.5**, in kPa;

where the lower boundary of region **I** is included in the grillage and the requirements of this Chapter cover region of ice strengthening **I** and **II** (refer to **3.10.1.3.4**), the following values of p shall be adopted:

$p = p_{kI}$, if the distance from the plating of the upper supporting structure of the grillage to the lower boundary of region **I** is greater than $1,2b$, otherwise $p = p_{kII}$;

p_{kI} , p_{kII} – ice pressure in regions **I** and **II** (refer to **3.10.3.2**);

b – vertical distribution of ice pressure, in m, in the region under consideration in accordance with **3.10.3.3** or **3.10.3.6**.

If $b > l$, $b = l$ shall be adopted for the purpose of determining W_{f0} and A_f ;

a – conventional frame spacing, in m, as measured at side;

l – design frame span, in m, to be determined in accordance with Table 3.10.4.3.1-1 in the case of transverse main framing and with Table 3.10.4.3.1-2 in the case of web framing;

$Y = 1 - 0,5\beta$;

$\beta = b/l$, but not greater than 1;

k_k – factor equal to 0,9 for conventional frames joined with knees to bearing stringers in a side grillage with deep frames, and equal to 1,0 in other cases;

E - factor equal to:

$$E = 4l_f(l - l_i)/l^2 \quad \text{якщо } l_i < 0,5l;$$

$$E = 1 \quad \text{якщо } l_i \geq 0,5l,$$

where: l_i - section of the span length l , in m, overlapped by the region of ice strengthening;

$\omega_f = 1 + k_c \Delta s/s_{as}$, for the purpose of simplified calculation in accordance with **3.10.4.2.4** $\omega_f = 1,15$ may be adopted;

s_{as} - actual frame web thickness, in mm;

for Δs - refer to **1.1.5.1**;

$k_c = 0,9$ - for rolled profile;

$k_c = 0,85$ - for welded profile.

3.10.4.3.2 The web area A_f , in cm², of a conventional frame shall not be less than determined by the formula

$$A_f = (8,7pabk_2k_3k_4/R_{eH}) + 0,1h_f\Delta s, \quad (3.10.4.3.2)$$

where: $k_2 = 4/k$;

$k_3 = 1/[1 + z + (\sqrt{2z}) \cdot \beta^{2,5}]$, or $k_3 = 0,7$ whichever is greater;

$$z = (a/l)^2/2\beta;$$

for p, a, b, l, k, β - refer to **3.10.4.3.1**, the values of b and l adopted shall not exceed the distance between bracket ends;

$k_4 = 1$ - where no side stringer is provided;

$k_4 = 0,9$ - where there is a side stringer in the span;

$k_4 = 0,8$ - where there is a side stringer in the frame span for which effective flange continuity is ensured;

h_f - frame web height, in cm; $h_f = 0,89h_s$ for symmetric bulb and $h_f = 0,84h_s$ for asymmetric bulb;

h_s - rolled profile height, in cm;

for Δs - refer to **1.1.5.1**.

3.10.4.3.3 The actual web area A_a , in cm², shall be determined in accordance with **3.10.4.2.5**. When a simplified calculation is performed in accordance with **3.10.4.2.4**, the value of A_a shall be at least by 10 % greater than the required web area.

3.10.4.3.4 The web thickness s_f , in mm, of a conventional frame shall be adopted not less than the greater of the following values:

$$s_f = (k_s p a / R_{eH}) + \Delta s; \quad (3.10.4.3.4-1)$$

$$s_f = 0,0114h_f \sqrt{R_{eH} + \Delta s}, \quad (3.10.4.3.4-2)$$

where: $k_s = 1,4W_f/W_{af}$, but not less than $k_s = 1,0$;

for W_f - refer to **3.10.4.3.1**;

W_{af} - actual ultimate section modulus, in cm³, of a conventional frame, to be determined in accordance with **3.10.4.2.6**, (as a first approximation or for the purpose of the simplified calculation in accordance with **3.10.4.2.4**, $W_f = W_{af}$ shall be adopted);

for p, a - refer to **3.10.4.3.1**;

for h_f - refer to **3.10.4.3.2**;

for Δs - refer to **1.1.5.1**.

3.10.4.3.5 The face plate breadth c_f , in mm, of a conventional frame made of bulb or T-sections shall not be less than the greater one of the following values

$$c_f = (0,0145 R_{eH} W_f / W_{af}) \cdot (h_f / s_{af} - 0,98) \cdot \sqrt{t_f s_{af}}, \quad (3.10.4.3.5-1)$$

$$c_f = 2,5t_f, \quad (3.10.4.3.5-2)$$

$$c_f = 69,6 s_{af} \sqrt{h_f(\beta^2 - 0,0029)/t_f}, \quad (3.10.4.3.5-3)$$

where: $\beta = (2 - \alpha)l_s/ah_s$, but not less than $\beta = 0,055$;

$\alpha = (s_{af}/s_{as})^2 + 0,01h_f s_{as}/as_{af}$, but not less than $\alpha = 1$;

for W_f - refer to **3.10.4.3.1**;

for W_{af} - refer to **3.10.4.3.4**;

s_{af} – actual web thickness of a conventional frame, in mm;

t_f – face plate breadth of a conventional frame, in mm (for beams made of bulbs $t_f = 1,5s_{af}$ shall be adopted);

for h_f – refer to **3.10.4.3.2**;

s_{as} – actual shell plating thickness, in mm;

for a – refer to **3.10.4.3.1**;

l_s – the greatest spacing, in m, of adjacent stringers crossing the frame span or the greatest distance, in m, between the stringer and the supporting section.

In the case of frames made of standard profiles, compliance with the requirements for the face plate breadth may not be verified where a simplified calculation in accordance with 3.10.4.2.4 is carried out.

3.10.4.3.6 Where the face plate is lacking, the height of a conventional frame shall not be less than determined by the formula

$$h_f = 23,4(s_{af} - \Delta s) / \sqrt{R_{eH}}, \quad (3.10.4.3.6)$$

where for s_{af} – refer to **3.10.4.3.5**;

for Δs – refer to **1.1.5.1**.

A distance between side stringers or a side stringer and a supporting structure for conventional frames without face plates shall not exceed 1,3 m.

3.10.4.4 Side and intercostal stringers as part of transverse framing with deep frames.

3.10.4.4.1 The ultimate section modulus W_s , in cm³, of a bearing side stringer shall not be less than determined by the formula:

$$W_s = W_{s0}k_s, \quad (3.10.4.4.1)$$

where: $W_{s0} = 125k_s^p pa^2 b Q \omega_s$;

$k_s = 1/(1 + \sqrt{1 - 0,8\gamma_s^2})$, for the purpose of simplified calculation in accordance with **3.10.4.2.4** $k_s = 0,63$ shall be adopted;

$\omega_s = 1 + 0,95\Delta s/s_{as}$, for the purpose of simplified calculation in accordance with **3.10.4.2.4** $\omega_s = 1,15$ shall be adopted;

$k_s^p = 0,82 - 0,55a_1/l^p \geq 0,6$ with $l^p \geq a_1$;

$k_s^p = 0,82 l^p/a_1 - 0,55 \geq 0,6$ l^p/a_1 with $l^p < a_1$;

for l^p – refer to **3.10.3.4**;

for p , b – refer to **3.10.4.3.1**;

a_1 – deep frame spacing, in m, as measured along the side;

$Q = C_{1i} + C_{2i}b/l + C_{3i}\psi_f + C_{4i}/\gamma_f + C_{5i}\psi_f/\gamma_f$;

for the purpose of simplified calculation in accordance with **3.10.4.2.4** $Q = C_{6i} + C_{2i}b/l$;

i – factor taking up the following values:

$i = 1$ with $m = 1$;

$i = 2$ with $m \geq 2$;

m – number of side stringers in a grillage;

for C_{1i} , C_{2i} , ..., C_{6i} – refer to Table 3.10.4.4.1.

Table 3.10.4.4.1

i	C_{1i}	C_{2i}	C_{3i}	C_{4i}	C_{5i}	C_{6i}
1	0,003	0,132	0,398	0,584	-0,785	0,320
2	0,363	0,11	-0,078	0,186	-0,202	0,358

for l , γ_f – refer to **3.10.4.3.1**;

ψ_f – factor to be adopted equal to the lesser of the following:

$\psi_f = W_{af}/W_{f0}$;

$\psi_f = 1,4k_f$;

for W_{f0} , k_f – refer to **3.10.4.3.1**;

for W_{af} – refer to **3.10.4.3.4**;

$\gamma_c = A_s/A_a$;

for A_s – refer to **3.10.4.4.2**;

for A_a - refer to **3.10.4.4.3**;
 S_a - actual web thickness of a side stringer, in mm;
 for Δs - refer to **1.1.5.1**.

3.10.4.4.2 The web area A_s , in cm², of a side stringer shall not be less than determined by the formula

$$A_c = 8,7k_s^p abQn/R_{eH} + 0,1h_s\Delta s, \quad (3.10.4.4.2)$$

where for p , a , b - refer to **3.10.4.3.1**;
 n - number of frames fitted between two adjacent deep frames;
 k_s^p, Q - refer to **3.10.4.4.1**;
 h_c - web height of a bearing side stringer, in cm;
 for Δs - refer to **1.1.5.1**.

3.10.4.4.3 The actual web area A_a , in cm², of a side stringer shall be determined in accordance with **3.10.4.3.3**.

3.10.4.4.4 The web thickness s_s , in mm, of a side stringer shall not be less than determined by the formula

$$S_s = 2,63c_1\sqrt{\gamma_s R_{eH}/[5,34 + 4(c_1/c_2)^2]} + \Delta s, \quad (3.10.4.4.4)$$

where: c_1, c_2 - the shorter and longer side, in m, of the panels into which the stringer web is divided by its stiffeners;
 or an unstiffened web, $c_1 = 0,01(h_s - 0,8h_f)$, $c_2 = a_1$;
 for h_s - refer to **3.10.4.4.2**;
 for h_f - refer to **3.10.4.3.2**;
 for a_1 i γ_s - refer to **3.10.4.4.1**;
 for Δs - refer to **1.1.5.1**.

3.10.4.4.5 The web height h_s , in cm, of a side stringer shall not be less than determined by the formula

$$h_s = 2 h_f, \quad (3.10.4.4.5)$$

where for h_f - refer to **3.10.4.3.2**.

3.10.4.4.6 The face plate thickness of a side stringer shall not be less than its actual web thickness.

3.10.4.4.7 The face plate breadth c_s , in mm, of a side stringer shall not be less than the greater of the following values:

$$c_s = 0,0165 R_{eH}W_s \sqrt{t_s s_{as}} \cdot (h_s/s_{as} - 2,6)/W_{as}; \quad (3.10.4.4.7-1)$$

$$c_s = 7,5t_s, \quad (3.10.4.4.7-2)$$

where for W_s - refer to **3.10.4.4.1**;

W_{as} - actual ultimate section modulus, in cm³, of a side stringer, to be determined in accordance with **3.10.4.2.6**, ((in first approximation or for the purpose of simplified calculation in accordance with **3.10.4.2.4** $W_{as} = W_s$ shall be adopted);

T_s - face plate thickness, in mm, of a bearing stringer;
 for s_{as} - refer to **3.10.4.4.1**;
 for h_s - refer to **3.10.4.4.2**.

Bearing stringer without face plate (flat bar) is not permitted.

3.10.4.4.8 The web height h_{is} , in cm, of an intercostal stringer in way of a conventional frame shall not be less than determined by the formula

$$h_{is} = 0,8 h_f, \quad (3.10.4.4.8)$$

for h_f - refer to **3.10.4.3.2**.

3.10.4.4.9 The web thickness of an intercostal stringer shall not be less than that of a conventional frame, as required in accordance with **3.10.4.3.4**.

3.10.4.5 Deep frames as part of transverse framing.

3.10.4.5.1 The ultimate section modulus W_{wf} , in cm^3 , of a deep frame shall not be less than determined by the formula

$$W_{wf} = W_{wf0} k_{wf}, \quad (3.10.4.5.1)$$

where: $W_{wf0} = 250 k_{wf}^p p a b l_{wf} (1 - 0,5b/l_{wf} + k_m G) \omega_{wf} / R_{cH}$;

$$k_{wf} = 1 / (1 + \sqrt{1 - 0,8\gamma_{wf}^2});$$

$$G = 2nQ_m(1 - R), \quad G = 2nQ_m(1 - R);$$

for the purpose of a simplified calculation in accordance with **3.10.4.2.4**, $k_{wf} = 0,63$ shall be adopted;

$$G = nQ_m;$$

for n – refer to **3.10.4.4.2**;

for k_m – refer to Table 3.10.4.5.1-1;

Table 3.10.4.5.1-1

m	1	2	3	4	5	6
k_m	1,0	1,33	2,0	2,4	3,0	3,43

$$R = 0,5\sqrt{2\psi_s - (\psi_s\gamma_{s1})^2} \text{ with } \psi_s < 1/\gamma_{s1}^2;$$

$$R = 0,5/\gamma_{s1} \text{ with } \psi_s \geq 1/\gamma_{s1}^2;$$

$$\gamma_{wf} = A_{wf}/A_a;$$

$$\psi_s = W_{as}k_d/W_{s0};$$

γ_{c1} – factor to be adopted as the greater of the following:

$$\gamma_{c1} = \gamma_c/k_d, \text{ а } \gamma_{c1} = 0,7;$$

$$k_d = 1 \text{ with } m \leq 2;$$

$k_d = Q/Q_m$ with $m > 2$, for the purpose of a simplified calculation in accordance with **3.10.4.2.4** $k_d = 1,2$ with $m > 2$ shall be adopted;

$$Q_m = Q \text{ with } m = 1; 2;$$

$$Q_m = C_{m1} + C_{m2}[0,5b(\psi_f - 0,5)/l - \psi_f] \text{ with } m = 3; 4; 5; 6;$$

C_{m1}, C_{m2} – factors to be taken from Table 3.10.4.5.1-2;

Table 3.10.4.5.1-2

m	3	4	5	6
C_{m1}	0,5	0,417	0,333	0,292
C_{m2}	0,25	0,167	0,111	0,083

$\omega_{wf} = 1 + 0,95\Delta s/s_{af}$, for the purpose of a simplified calculation in accordance with **3.10.4.2.4** $\omega_{wf} = 1,15$;

for p, a, b – refer to **3.10.4.3.1**;

$m, l, Q, \psi_f, W_{s0}, \gamma_c$ – refer to **3.10.4.4.1**;

l_{wf} – span length, in m, of a deep frame, equal to the distance between supporting sections;

for W_{as} – refer to **3.10.4.4.7**;

$$k_{wf}^p = 0,82(1 - a_1/l^p) \geq 0,6 \text{ with } l^p \geq 2a_1;$$

$$k_{wf}^p = 0,41(l^p/a_1 - 1) \geq 0,3 \text{ } l^p/a_1 \text{ with } l^p < 2a_1;$$

for l^m – refer to **3.10.3.4**;

for a_1 – refer to **3.10.4.4.1**;

for A_{wf} – refer to **3.10.4.5.2**;

for A_a – refer to **3.10.4.5.3**;
 s_{awf} – actual thickness, in mm, of a deep frame web;
 for Δs – refer to **1.1.5.1**.

3.10.4.5.2 The web area A_{wf} , in cm², of a deep frame shall not be less than determined by the formula

$$A_{wf} = 8,7pabk_{wf}^p(1 + mG)/R_{eH} + 0,1h_{wf}\Delta s, \quad (3.10.4.5.2)$$

where for p , a , b – refer to **3.10.4.3.1**;
 for m – refer to **3.10.4.4.1**;
 for k_{wf}^p , G – refer to **3.10.4.5.1**;
 h_{wf} – deep frame web depth, in cm;
 for Δs – refer to **1.1.5.1**.

3.10.4.5.3 The actual web area A_a , in cm², of a deep frame shall be determined in accordance with **3.10.4.3.3**.

3.10.4.5.4 The web thickness s_{wf} , in mm, shall be adopted not less than the greater of the following values:

$$s_{wf} = k_s pa/R_{eH} + \Delta s; \quad (3.10.4.5.4-1)$$

$$s_{wf} = 2,63c_1\sqrt{\gamma_p R_{eH}/[5,34 + 4(c_1/c_2)^2]} + \Delta s, \quad (3.10.4.5.4-2)$$

where: $k_s = 1/(1,25 W_{wf}/W_{awf} - 0,75)$, but not less than $k_s = 1,0$;
 for W_{wf} and g_{wf} , refer to **3.10.4.5.1**;

W_{awf} – actual ultimate section modulus, in cm³, of a deep frame, to be determined in accordance with **3.10.4.2.6** (in the first approximation or for the purpose of the simplified calculation in accordance with **3.10.4.2.4**, $W_{awf} = W_{wf}$ shall be adopted);

for p , a – refer to **3.10.4.3.1**;

c_1 , c_2 – the shorter and the longer side, in m, of panels into which the web of a deep frame is divided by its stiffeners;
 for Δs – refer to **1.1.5.1**.

3.10.4.5.5 The face plate thickness of a deep frame shall not be less than the actual thickness of its web.

3.10.4.5.6 The face plate breadth c_{wf} , in mm, of a deep frame shall not be less than the greater of the following values:

$$c_{wf} = A_1 R_{eH} W_{wf} \sqrt{t_p s_{awf}} \cdot (h_{wf}/s_{awf} - A_2)/W_{awf}; \quad (3.10.4.5.6-1)$$

$$c_{wf} = A_3 t_{wf}; \quad (3.10.4.5.6-2)$$

where for W_{wf} – refer to **3.10.4.5.1**;

s_{awf} – refer to **3.10.4.5.4**;

t_{wf} – face plate thickness, in mm, of a deep frame;

s_{awf} – refer to **3.10.4.5.1**;

h_{awf} – refer to **3.10.4.5.2**;

$A_1 = 0,0039$; $A_2 = 1,4$; $A_3 = 5$, if the deep frame web is provided with stiffeners fitted approximately normal to the shell plating;

$A_1 = 0,0182$; $A_2 = 2,6$; $A_3 = 10$, if the deep frame web is provided with stiffeners fitted approximately parallel to the shell plating or if it is unstiffened.

Deep frame without face plate (flat bar) is not permitted.

3.10.4.6 Side and bottom longitudinals as part of longitudinal framing.

3.10.4.6.1 The ultimate section modulus W_l , in cm³, of a longitudinal shall not be less than determined by the formula:

$$W_l = W_{l0} k_l, \quad (3.10.4.6.1)$$

where: $W_{l0} = 125pb_1l(l - 0,5a)c^2\omega_l/R_{eH}$;

$k_l = 1/(1 + \sqrt{1 - k_s \gamma^2 l})$, for the purpose of simplified calculation in accordance with **3.10.4.2.4** for $k_l = 0,63$; $k_s =$ refer to **3.10.4.3.1**;

$c = 1$ – for bottom longitudinals and for side longitudinals where no panting frames are fitted;

$c = 1/(1 + 0,25/e)$ – for side longitudinals where panting frames are fitted;

$b_1 = k_0 b_2$;

$b_2 = b(1 - 0,25\bar{b})$ with $\bar{b} < 2$;

$b_2 = a$ with $\bar{b} \geq 2$;

$e = \bar{b} + 1$;

$\bar{b} = b/a$;

$k = 1 - 0,3/\bar{b}$;

$\omega_l = 1 + k_c \Delta s / s_{al}$, may be adopted for the purpose of the simplified calculation in accordance with **3.10.4.2.4** $\omega_l = 1,15$;

for p, b – refer to **3.10.4.3.1**;

a – spacing, in m, of longitudinals;

l – spacing, in m, of deep frames or floors;

$\gamma_l = A_l / A_a$;

for A_l – refer to **3.10.4.6.2**;

for A_a – refer to **3.10.4.6.3**;

s_{al} – actual web thickness, in mm, of a longitudinal;

for Δs – refer to **1.1.5.1**;

for k_c – refer to **3.10.4.3.1**.

3.10.4.6.2 The web area A_l , in cm², of a longitudinal shall not be less than determined by the formula

$$A_l = 8,7pb_1 l c k_1 / R_{eH} + 0,1h_l \Delta s, \quad (3.10.4.6.2)$$

where for p – refer to **3.10.4.3.1**;

for b_1, l, c – refer to **3.10.4.6.1**;

k_1 – factor to be adopted as the greater of the following:

$k_1 = 1/(1 + 0,76a_0/l)$, або $k_1 = 0,8$;

for a_0 – refer to **3.10.4.1**;

h_6 – web height, in cm, of a longitudinal;

for Δs – refer to **1.1.5.1**.

3.10.4.6.3 The actual web area A_a , in cm², of a longitudinal shall be determined in accordance with **3.10.4.3.3**.

3.10.4.6.4 The web area s_l , in mm, of a longitudinal shall be adopted not less than the greater one of the following values:

$$s_l = k_s p b_1 / R_{eH} + \Delta s, \text{ or } (3.1.4.6.4-1)$$

$$s_l = 0,013h_l \sqrt{R_{eH}} + \Delta s, \quad (3.1.4.6.4-2)$$

where: $k_s = 1,4W_l / W_{al}$, but not less than $k_s = 1,0$;

for W_l – refer to **3.10.4.6.1**;

W_{al} – actual ultimate section modulus, in cm³, of a longitudinal, to be determined in accordance with **3.10.4.2.6** (in the first approximation or for the purpose of the simplified calculation in accordance with **3.10.4.2.4** adopted $W_{al} = W_l$);

for p – refer to **3.10.4.3.1**;

for b_1 – refer to **3.10.4.6.1**;

for h_l – refer to **3.10.4.6.2**;

for Δs – refer to **1.1.5.1**.

3.10.4.6.5 The face plate breadth c_l , in mm, of a longitudinal of bulb or T-bar shall not be less than the greater of the following values:

$$c_l = 0,0145 R_{eH} W_l \sqrt{t_l s_{al}} \cdot (h_l / s_{al} - 0,98); \quad (3.10.4.6.5-1)$$

$$c_l = 2,5t_l; \quad (3.10.4.6.5-2)$$

$$c_l = 69,6s_{al} \sqrt{h_6(\beta^2 - 0,0029)}, \quad (3.10.4.6.5-3)$$

where: $\beta = (2 - \alpha)l_s / (\alpha h_6)$, but not less than $\beta = 0,055$;
 $\alpha = (s_{al}/s_{as})^2 + 0,01h_l s_{as} / (as_{al})$, but not less than $\alpha = 1$;
for W_l – refer to **3.10.4.6.1**;
for W_{al} – refer to **3.10.4.6.4**;
 s_{al} – actual web thickness, in mm, of a longitudinal;
 t_6 – face plate thickness, in mm, of a longitudinal (for longitudinals of bulb, $t_l = 1,5s_{al}$ shall be adopted);
for h_l – refer to **3.10.4.6.2**;
 s_{as} – actual shell plating thickness, in mm;
for a – refer to **3.10.4.6.1**;
 l_s – maximum spacing, in m, of adjacent transverse members crossing the span of a longitudinal.

As far as longitudinals made of standard profiles are concerned, conformance with the requirements for the face plate breadth may not be verified in case of carrying out a simplified calculation in accordance with **3.10.4.2.4**.

3.10.4.6.6 Where the face plate is lacking, the height of a longitudinal shall not be less than the value determined by Formula (3.10.4.3.6) where s_{af} shall be assumed equal to s_{al} – refer to **3.10.4.6.5**. A distance between deep frames or a deep frame and a supporting structure for longitudinals without face plates shall not exceed 1,3 m.

3.10.4.7 Deep frames as part of longitudinal framing.

3.10.4.7.1 The ultimate section modulus W_{wfs} , in cm³, of a deep frame shall not be less than determined by the formula:

$$W_{wfs} = W_{wfo} k_p, \quad (3.10.4.7.1)$$

where: $W_{wfo} = pabk_{wf}^p(1 + k_g) \cdot (Q - k_g R/e) \omega_{wfs} / R_{cH}$;

$$k_{wf} = 1 / (1 + \sqrt{1 - 0,8\gamma_{wf}^2});$$

$$Q = 2 - N;$$

$$N = \sqrt{2\psi_l \beta - (\psi_l \gamma_l)^2} \quad \text{with } \psi_l < \beta / \gamma_l^2;$$

$$N = \beta / \gamma_l^2 \quad \text{with } \psi_l \geq \beta / \gamma_l^2;$$

$$R = \beta \psi_l / \sqrt{(\psi_l \gamma_l)^2 + 4}.$$

For the purpose of a simplified calculation in accordance with **3.10.4.2.4**, $k_{wf} = 0,63$, $N = 1,1\beta$, $R = 0,33\beta$;

$$\beta = b_1 e / b;$$

for p , b – refer to **3.10.4.3.1**;

for a , l , b_1 , e , γ_l – refer to **3.10.4.6.1**;

for k_{wf}^p , ω_{wfs} – refer to **3.10.4.5.1**;

k_g – factor to be adopted as the lesser of the following:

$$k_g = 0,5(eQ/R - 1);$$

$$k_g = 0,5[k - 0,25(e + 1)];$$

k – number of longitudinals in a deep frame span;

$$\psi_l = W_{al} / W_{l0};$$

for W_{al} – refer to **3.10.4.6.4**;

for W_{l0} – refer to **3.10.4.6.1**;

$$\gamma_{wfs} = A_{wfs} / A_a;$$

for A_{wfs} – refer to **3.10.4.7.2**;

for A_a – refer to **3.10.4.7.3**.

3.10.4.7.2 The web area A_{wfs} , in cm², of a deep frame shall not be less than determined by the formula

$$A_{wfs} = 8,7pbk_{wf}^p Q / R_{cH} + 0,1h_{wfs} \Delta s, \quad (3.10.4.7.2)$$

where for p, b – refer to **3.10.4.3.1**;
 for l – див. **3.10.4.6.1**;
 for Q – refer to **3.10.4.7.1**;
 h_p – deep frame web height, in cm;
 for Δs – refer to **1.1.5.1**.

3.10.4.7.3 The actual web area A_a , in cm², of a deep frame shall be determined in accordance with **3.10.4.3.3**.

3.10.4.7.4 The web thickness of a deep frame shall not be less than the greater of the values determined by Formulae (3.10.4.5.4-1), (3.10.4.5.4-2) while W_{wf} shall be in accordance with **3.10.4.7.1** and a shall be in accordance with **3.10.4.6.1**.

3.10.4.7.5 The web height of a deep frame shall not be less than determined by the formula:

$$h_{wf} = 2h_l \quad (3.10.4.7.5)$$

where for h_l , refer to **3.10.4.6.2**.

3.10.4.7.6 The face plate thickness of a deep frame shall not be less than its actual web thickness.

3.10.4.7.7 The face plate breadth of a deep frame shall be determined in accordance with **3.10.4.5.6** while W_{wf} shall be in accordance with **3.10.4.7.1**. The deep frame without face plate (flat bar) is not permitted.

3.10.4.8 Additional frames and horizontal diaphragms as part of longitudinal framing.

3.10.4.8.1 The web height of an additional frame $h_{ad,f}$, in cm, (refer to 3.10.2.3) in way of a longitudinal shall not be less than determined by the formula

$$h_{ad,f} = 0,8h_l, \quad (3.10.4.8.1)$$

where: h_l – web height, in cm, of a longitudinal.

3.10.4.8.2 The web thickness of an additional frame shall not be less than that of a longitudinal, as required in accordance with **3.10.4.6.4**.

3.10.4.8.3 The cross-sectional area of a horizontal diaphragm forming part of double-side structure where the outboard side is longitudinally framed shall not be less than the web area of a deep frame (vertical diaphragm) in accordance with **3.10.4.7.2**.

3.10.4.9 Plate structures.

3.10.4.9.1 The thickness of plate structures forming part of web framing of side grillages (deep frames, side stringers) shall be determined in accordance with **3.10.4.4.4**, **3.10.4.5.4**, **4.10.4.7.4**.

3.10.4.9.2 The plate structure thickness of decks and platforms, as well as of double bottom, bottom stringers and centre girder shall not be less than s_{ps1} , in mm, to be determined by the formula:

$$s_{ps1} = s_{ps0} + \Delta s, \quad (3.10.4.9.2)$$

where: $s_{ps0} = s_{ps01}$ - if the plate structure is stiffened approximately normal to the shell plating;

$s_{ps0} = s_{ps02}$ - if the plate structure is unstiffened approximately normal to the shell plating (permitted for **Ice1**, **Ice2**, **Ice3** ice class ships);

$$s_{ps01} = b \{ 0,8p_1/R_{eH} - 0045k_2[1+4(c_{sp}/k_2b)^2] \cdot (s_{sp0}/10c_{sp})^{3,5} \};$$

$$s_{ps02} = 0,95p_1b/R_{eH};$$

$$p_1 = k_1p;$$

for k_1 - refer to Table 3.10.4.9.2;

$$k_2 = k_T \cdot (k_p)^{1/2};$$

$$k_T = 0,17\Delta^{1/6}, \text{ but not less than } 1,0;$$

k_p - shall be in accordance with 3.10.3.5.1 as far as icebreakers are concerned;

$$k_p = 1 - \text{for ice class ships};$$

for Δ - refer to **3.10.3.2.1**;

for p, b – refer to **3.10.4.3.1**;

c_{sp} - spacing, in m, of stiffeners in a plate structure or distance, in m, between other framing members fitted approximately normal to the shell plating;

for s_{sp0} - refer to **3.10.4.1**;

for Δs - refer to **1.1.5.1**.

Table 3.10.4.9.2

Ice class	k_1
Ice1, Ice2, Ice3, Ice4, Ice5	1,3
Ice6, Icebreaker1	1,2
Icebreaker2	1,1
Icebreaker3, Icebreaker4	1,0

3.10.4.9.3 In addition to the requirements of 3.10.4.9.2, the thickness of plate structures in decks and platforms, where the side is transversely framed, shall not be less than s_{ps2} , in mm, to be determined by the formula

$$v = s_{ps0} + \Delta s, \quad (3.10.4.9.3)$$

where: $s_{ps0} = 0,866 \cdot [1,1 p_1 b \cdot (1 - b/4l)/R_{eH} - 0,5 W_{af} l \cdot (h_f/10l)^{1,5} \cdot 10^{-3}/(\omega_f a l l_2) - 0,1 f_{st}/a_1]/\alpha$;

p_1 – refer to **3.10.4.9.2**;

$l = 0,5(l_1 + l_2)$;

$\alpha = 1 - a_2/a$;

l_1, l_2 - distance, in m, from the plate structure under consideration to the nearest plate structures (decks, platforms, side stringers, inner bottom plating) on both sides;

a_1 - spacing, in m, of plate structure stiffeners fitted approximately normal to shell plating and welded thereto;

f_{st} - cross-sectional area of stiffener, in cm^2 , without effective flange; where stiffeners are fitted parallel to the shell plating or snipped, $f_{st} = 0$ shall be adopted;

for b, a, ω_f – refer to **3.10.4.3.1**;

for W_{af} – refer to **3.10.4.3.4**;

for h_f – refer to **3.10.4.3.2**;

a_2 - length, in m, of unstiffened section of opening in plate structure for the passage of a conventional frame, as measured on the shell plating;

for Δs - refer to **1.1.5.1**.

3.10.4.9.4 Transverse bulkhead plating thickness where the side is longitudinally framed and the floor and bilge bracket thickness where the bottom is longitudinally framed shall not be less than s_{ps3} , in mm, to be determined by the formula:

$$s_{ps3} = s_{ps0} + \Delta s, \quad (3.10.4.9.4)$$

where: $s_{ps0} = a \{ 1,8 p_2 / R_{eH} - 0,009 \cdot [1 + (a/k_g)^2] \cdot (s_{sp0}/10a)^{3,5} \}$;

$p_2 = p_1/k_2$;

for p_1, k_2 – refer to **3.10.4.9.2**;

$k_g = 0,4 k_2 b$, but not greater than $k_g = a$;

a - spacing, in m, of side (bottom) longitudinals;

for b – refer to **3.10.4.3.1**;

for s_{sp0} – refer to **3.10.4.1**;

for Δs – refer to **1.1.5.1**.

3.10.4.9.5 The plate structure thickness of transverse bulkheads in a transversely framed side, and of floors in a transversely framed bottom shall not be less than s_{ps4} , in mm, to be determined by the formula

$$s_{ps4} = s_{ps0} + \Delta s, \quad (3.10.4.9.4)$$

where: $s_{ps0} = a \{ 1,8 p_2 / R_{eH} - 0,009 \cdot [1 + (a/k_g)^2] \cdot (s_{sp0}/10a)^{3,5} \}$;

$k_g = 0,4 k_2 b$, but not greater than $k_g = c_{sp}$;

for b – refer to **3.10.4.3.1**;
 for k_2, c_{sp} – refer to **3.10.4.9.2**;
 for p_2 – refer to **3.10.4.9.4**;
 a - spacing, in m, of conventional frames (for plate structures of bulkheads) or floors (for plate structures of floors);
 for s_{ps0} – refer to **3.10.4.1**;
 for Δs – refer to **1.1.5.1**.

3.10.4.9.6 In any case, the plate thickness of decks and platforms, transverse bulkheads, inner bottom, floors and bilge brackets, bottom stringers and centre girder shall not be less than s_{ps} , in mm, to be determined by the formula

$$s_{ps} = s_{ps0} + \Delta s, \quad (3.10.4.9.6)$$

where: $s_{ps0} = (q/n)^{1/3}$ with $q \leq q_1$;

$$s_{ps0} = 0,455 \cdot [q/R_{eH} + \sqrt{(q/R_{eH})^2 + 1,32R_{eH}/n}] \quad \text{with } q_1 < q < q_2;$$

$$s_{ps0} = 1,73\sqrt{R_{eH}/n} \quad \text{with } q \geq q_2;$$

$q = 0,6p_1b \cdot (1 - 0,1bk_2/a)$ - for plate structures of decks and platforms, inner bottom, bottom stringers and centre girder in a longitudinally framed side or bottom;

$q = 0,89p_2a$ - for the rest of plate structures where the bottom is transversely framed and for all plate structures where the bottom and side are framed transversely;

for p_1, k_2 – refer to **3.10.4.9.2**;

for p_2 – refer to **3.10.4.9.4**;

$$q_1 = 0,353\sqrt{R_{eH}^3/n};$$

$$q_2 = 4,9q_1;$$

$$n = 0,294n_1/c_1^2;$$

$n_1 = [1 + (c_1/c_2)^2]^2$ - where the longer side of plate structure panel adjoins the shell plating;

$n_1 = 4$ - where the shorter side of plate structure panel adjoins the shell plating;

c_1, c_2 - the shorter and longer sides, in m, of panels into which a plate structure is divided by its stiffeners;

for b – refer to **3.10.4.3.1**;

a - spacing, of shell plating stiffeners, in m;

for Δs – refer to **1.1.5.1**.

3.10.4.9.7 The inertia moment i , in cm^4 , of stiffeners by which the plate structures are strengthened and which are fitted approximately normal to the shell plating shall not be less than determined by the formula

$$i = 0,01R_{eH}l^2 (10s_{ps}a + f_p), \quad (3.10.4.9.7)$$

where: l - span length, in m, of stiffener, not greater than $l = 6a$;

s_{ps} - thickness, in mm, of plate structure being strengthened;

a - spacing, in m, of stiffeners;

f_p - sectional area of stiffener, in cm^2 , without effective flange.

3.10.4.9.8 A horizontal grillage adjoining the shell plating in region of ice strengthening, but not reaching from side to side (deck or platform in way of large openings, horizontal diaphragm of double side, etc.) may be considered a platform if the sectional area of its plating (on one side) is not less than F , in cm^2 , to be determined by the formula

$$F = 6pb l^* \cdot (1 - b/4l)/R_{eH}, \quad (3.10.4.9.8)$$

where for p – refer to **3.10.3.2**;

for b – refer to **3.10.3.3**;

l^* - =design distribution length, in m, for the load taken up by the transverse main framing of side, to be adopted equal to l^p , or to l^p or $2a_1$, whichever is less, in the case of framing (transverse or longitudinal) including deep frames;

for l^p – refer to **3.10.3.4**;

for a_1 – refer to **3.10.4.4.1**;

for l – refer to **3.10.4.9.3**.

Otherwise, such a structure shall be considered a bearing side stringer.

A structure considered to be a platform shall comply with the requirements of **3.10.4.9** for the plate structures of platforms, and one considered to be a stringer, with the requirements of **3.10.4.4**.

3.10.4.10 Stems and sternframes.

3.10.4.10.1 The requirements of this paragraph for the area, section modulus and plate thickness of stem shall be complied with on the stem span from the keel to a level extending above the upper boundary of the ice strike by a value of H_I (refer to Table 3.10.4.10.1). In the case of icebreakers, this stem shall extend up to the nearest deck or platform lying higher than this level. Outside the borders of the area considered, the stem scantlings may gradually reduce and the cross-sectional area of the bar shall not be less than required in **2.10.4** while the plate thickness of a combined or plate stem shall not be less than ks (where s is the shell plating thickness in way of ice strike in region **AI**, for k , refer to Table 3.10.4.10.1).

Table 3.10.4.10.1

Parameter	Ice class ships						Icebreakers			
	Ice1	Ice2	Ice3	Ice4	Ice5	Ice6	Ice-breaker1	Ice-breaker2	Ice-breaker3	Ice-breaker4
Section H_I , in m, from top of ice belt to upper boundary of ice strengthening of the stem	0,5	0,5	0,6	0,7	0,8	0,9	1,0	1,5	1,75	2,0
Factor k of stem plate thickening above the upper boundary of strengthening	1,25	1,2	1,15	1,1	1,1	1,05	1,0	1,0	1,0	1,0
Factor k_k from Formula (3.10.4.10.1-1)	0,3	0,34	0,4	0,54	0,66	1,02	1,43	1,75	1,96	2,17
Depth of centreline vertical web h_v , in m, by which the stem is strengthened	0,5	0,5	0,5	0,6	1,0	1,3	Longitudinal bulkhead in fore peak centreline			

The cross-sectional area S , in cm^2 , of stem irrespective of configuration shall not be less than determined by the formula

$$S = k_k \eta f(\Delta), \quad (3.10.4.10.1-1)$$

where: k_k – factor whose values shall be obtained from Table 3.10.4.10.1;

$$f(\Delta) = 0,031\Delta + 137 \quad \text{at } \Delta < 5000\tau;$$

$$f(\Delta) = \Delta^{2/3} \quad \text{at } \Delta \geq 5000\tau;$$

Δ - displacement, in t;

η – application factor of mechanical properties of material determined according to **1.1.4.3**.

The section modulus W , in cm^3 , of the stem cross-sectional area about an axis perpendicular to the centreline shall not be less than determined by the formula

$$W = 1,16\eta pb, \quad (3.10.4.10.1-2)$$

where for p , b – refer to **3.10.4.3.1** as far as region of ice strengthening **AI** is concerned;

η – application factor of mechanical properties of material determined according to **1.1.4.3**.

To be included in the design cross-sectional area of a combined or plate stem are areas of shell plates and centreline girder or of longitudinal bulkhead on the centreline on a breadth not exceeding ten times the thickness of relevant plates.

The plate thickness s , in mm, of combined and plate stems, as well as of the structure shown in Fig. 3.10.2.6.2-2, shall not be less than determined by the formula

$$s = 1,2 \cdot [(s_{sp} a_b \sqrt{R_{eH}^H / R_{eH}}) / a_{sp} + \Delta s_s], \quad (3.10.4.10.1-3)$$

where for s_{sp} , Δs_{sp0} – refer to **3.10.4.1** as far as the region of ice strengthening **AI** is concerned;

a_b – spacing, in m, of transverse brackets of stem;

a_{sp} – main framing spacing, in m, in way of shell plating in the region of ice strengthening **AI**, which was adopted when determining s_{sp0} ;

R_{eH}^{sp} – yield stress, in MPa, of shell plating material, which was adopted when determining s_{sp0} ;

R_{eH} – yield stress, in MPa, of stem plate material.

In this case, the plate thickness s , in mm, of combined and plate stems shall not be less than determined by the formula

$$s = s_{sterm} + \Delta s_{sp0}, \quad (3.10.4.10.1-4)$$

where: $s_{sterm} = 18,7 a_b \sqrt{p_{AI} / R_{eH}}$;

for Δs_{sp0} , a_b , R_{eH} – refer to Formula (3.10.4.10.1-3);

p_{AI} – ice pressure for icebreakers according to 3.10.3.5.1, for ice class ships according to **3.10.3.2.1**.

3.10.4.10.2 Sternframe.

The cross-sectional area S , in cm^2 , of sternframe shall not be less than determined by the formula:

$$S = k S_0, \quad (3.10.4.10.2)$$

where: k – factor whose values shall be obtained from Table 3.10.4.10.2;

S_0 – cross-sectional area of stampost or rudderpost, cm^2 , in required for ships without ice class in accordance with **2.10.4**.

For sternframe of single screw vessels of ice classes **Ice1**, **Ice2**, **Ice3**, without rudderpost, or having a steering wheel spindle «Symplex», cross-sectional area of sternframe sole are accepted the largest, based on those required by **2.10.4.2.5** (taking into account **2.2.2.2**, Part III «Equipment, Arrangements and outfit») or by the Formula (3.10.4.10.2), whichever is greater.

If the sternframe has a bracket for semi-suspended rudder, then the dimensions of the bracket shall be determined according to **2.10.4.4** taking into account **2.2.2.2**, Part III «Equipment, Arrangements and outfit».

The sternframe cross-sectional area of twin-screw ice class ships or icebreakers shall not be less than rudderpost area according to **3.10.4.10.2**.

Table 3.10.4.10.2

Ice strengthening factor k	Ice class								
	Ice1	Ice2	Ice3	Ice4	Ice5	Ice6, Icebreaker1	Icebreaker2	Icebreaker3	Icebreaker4
Propeller post	1,1	1,1	1,15	1,25	1,5	1,75	2	2,5	3
Rudder post and sternframe sole	1,15	1,15	1,25	1,5	1,8	2	2,5	3,5	4

3.10.4.11 Bulbous bow.

3.10.4.11.1 Thickness of centreline longitudinal bulkhead within the area in accordance with Thickness of centreline longitudinal bulkhead within the area in accordance with 3.10.2.4.2 shall not be less than half the thickness of the bulb shell plating shall not be less than half the thickness of the bulb shell plating.

3.10.4.11.2 Within its vertical extent the bulb shall be strengthened by transverse brackets spaced not more than 0,6 m apart (refer to **3.10.2.6.4**) and carried to the nearest transverse bulkhead. The thickness of the brackets shall not be taken less than half the thickness of the bulb shell plating.

3.10.4.11.3 The thickness of shell plating, in mm, of **Ice4**, **Ice5**, **Ice6** class ships, shall not be less than determined by the Formula (3.10.4.1), where p is determined by Formulae

$$p_1 = p_0 / (\cos\alpha \cdot \cos\beta); \quad (3.10.4.11.3-1)$$

$$p_2 = 2700 / (\text{tg}^2\beta \cdot \cos\alpha); \quad (3.10.4.11.3-2)$$

whichever is greater

where: p_0 - shall be obtained from Table 3.10.4.11.3;

α and β (refer to Fig. 3.10.4.11.3) are determined in cross-sections within $0,25L_b$, $0,5 L_b$, $0,75 L_b$ from the bulb edge, remote from the main plane at a distance $d = d_5 - d_1$.

For α and $\beta > 60^\circ$, α and $\beta = 60^\circ$.

For $\beta < 20^\circ$, $\beta = 20^\circ$;

L_b - length of the bulb according to Fig. 3.10.4.11.3;

d_1 - as defined in Table 3.10.4.11.3.

In any case the bulb shell plating shall not be taken less than shell plating in region **AI**.

Table 3.10.4.11.3

Ice class ships	Ice4	Ice5	Ice6
d_1 , in m	0,24	0,32	0,44
p_0 , in kPa	6800	7500	9000
b_0 , in m	0,39	0,52	0,72

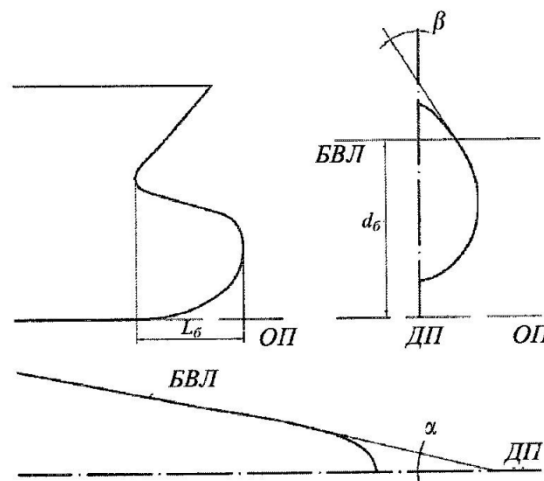

Fig. 3.10.4.11.3 Bulb design parameters L_b , α , β .

3.10.4.11.4 Bulb frame web area (refer to **3.10.4.2.5**), in cm^2 , shall not be less than determined by Formula

$$A_f = 8,7pba / R_{eH} + 0,1h_f\Delta s, \quad (3.10.4.11.4)$$

where: b - ice load distribution height in bulb shell plating glancing impact area, in m, determined by Formula

$$b = b_0 / \cos\beta \leq l;$$

b_0 as defined in Table 3.10.4.11.3;

α and β as defined in **3.10.4.11.3**;

a - transverse framing spacing, in m;

p - pressure, in kPa, determined in accordance with **3.10.4.11.3**;

h_f - frame web depth, in cm; for a flat bulb $h_f = 0,84h$, where h - profile depth;

l - estimated span of the frame, in m;

for Δs - refer to **1.1.5.1**.

3.10.4.11.5 Frame section modulus W_f , in cm^3 , shall not be taken less than

$$W_f = k_f W_{f0}, \quad (3.10.4.11.5)$$

where: $k_f = 1/(1 + \sqrt{1 - K_{np}\gamma_f^2})$;

$$\gamma_f = A_f/A_a ;$$

A_a - actual web area, in cm^2 , determined in accordance with **3.10.4.2.5**;

A_f - площа стінки, cm^2 , determined in accordance with **до 3.10.4.11.4**;

$K_p = 1,0$ – for flat bulb;

$K_p = 0,8$ – elsewhere;

$$W_{f0} = 250pbalY\omega_f/R_{eH} ;$$

p - as defined in **3.10.4.11.3**;

a - transverse framing spacing, in m;

l - estimated span of the frame, in m, assumed equal to the distance between the support cross sections (refer to

3.10.4.2.5);

b - ice load distribution height in bulb shell plating, in m, as defined in **3.10.4.11.3**;

$$Y = 1 - 0,5 b/l ;$$

$$\omega_f = 1,15.$$

3.10.4.11.6 The thickness of frame web shall not be taken less than:

$$s_f = 0,011 h_f \sqrt{R_{eH}} + \Delta s \geq 0,35s \sqrt{R_{eH}}/235, \quad (3.10.4.11.6-1)$$

where for h_f i Δs – refer to **3.10.4.11.4**;

s – bulb plating thickness, as defined in **3.10.4.11.3**.

The following ratios of the frame cross-section shall be provided:

$$h_f/s_f \leq 282/\sqrt{R_{eH}} - \text{for flat bulb}; \quad (3.10.4.11.6-2)$$

$$h_f/s_f \leq 805/\sqrt{R_{eH}} - \text{elsewhere}; \quad (3.10.4.11.6-3)$$

$$b_{f,p}/s_{f,p} \leq 5; \quad (3.10.4.11.6-4)$$

$$b'_{f,p}/s_{f,p} \leq 155/\sqrt{R_{eH}}; \quad (3.10.4.11.6-5)$$

where: s_f, h_f – frame web thickness and depth, in mm;

$b_{f,p}, s_{f,p}$ - face plate breadth and thickness, in mm;

$b'_{f,p}$ – distance of face plate edge from frame web, in mm.

3.10.4.11.7 The scantling of side stringers and web frames inside the bulb shall be taken based on the requirements of **3.10.4.4** and **3.10.4.5** with p as defined in **3.10.4.11.4**.

3.10.4.11.8 The thickness of side stringer web, as well as thickness of longitudinal plating, shall not be taken less than determined by Formula (3.10.4.4.4) with $\gamma_s = 1,0$.

3.10.4.11.9 The thickness of deep frame web, as well as thickness of longitudinal plating, shall not be taken less than determined by Formula (3.10.4.5.4-2) at $\gamma_p = 1,0$.

3.11 POLAR CLASS SHIPS

3.11.1 DESCRIPTION OF POLAR CLASSES AND THEIR APPLICATION

3.11.1.1 Application.

3.11.1.1.1 The Requirements for Polar Class ships apply to ships constructed of steel and intended for independent navigation in ice-infested polar waters.

The requirements of this chapter apply to ships, contracted for construction on or after 1 July 2017.

Note. The “contracted for construction” date means the date on which the contract to build the vessel is signed between the prospective owner and the shipbuilder. For further details regarding the date of “contract for construction”, refer to **1.2.2** Part I «Classification».

3.11.1.1.2 Polar class signs specified in Table 2.2.3.1-1, Part I «Classification», may be assigned to ships complying with the requirements of **3.11.2** and **2.8** «Machinery Requirements for Polar Class Ships» Part VII «Machinery Installations» are in addition to the open water requirements of the Register. If the hull and machinery are constructed such as to comply with the requirements of different Polar Classes, then both the hull and machinery are to be assigned the lower of these classes in the Certificate of Classification. Compliance of the hull or machinery with the requirements of a higher Polar Class is also to be indicated in the Certificate of Classification or equivalent.

3.11.1.1.3 Ships which are assigned a Polar Class notation and complying with the relevant requirements of **3.11.2** and **2.8** «Machinery Requirements for Polar Class Ships» Part VII «Machinery Installations», may be given the additional notation “**Icebreaker**” refer to **2.2.3.2** Part I «Classification».

3.11.1.1.4 For ships which are assigned a Polar Class notation, the hull form and propulsion power are to be such that the ship can operate independently and at continuous speed in a representative ice condition, as defined in Table 2.2.3.1-1, Part I «Classification» for the corresponding Polar Class. For ships and ship-shaped units which are intentionally not designed to operate independently in ice, such operational intent or limitations are to be explicitly stated in the Certificate of Classification or equivalent.

3.11.1.1.5 For ships which are assigned a Polar Class notation **PC 1** through **PC 5**, bows with vertical sides, and bulbous bows are generally to be avoided. Bow angles should in general be within the range specified in **3.11.2.3.1.5**.

3.11.1.1.6 For ships which are assigned a Polar Class notation **PC 6** and **PC 7**, and are designed with a bow with vertical sides or bulbous bows, operational limitations (restricted from intentional ramming) in design conditions are to be stated in the Certificate of Classification or equivalent.

3.11.1.2 Polar Classes.

3.11.1.2.1 The Polar Class (PC) notations and descriptions are given in Table 2.2.3.1-1, Part I «Classification». It is the responsibility of the Owner to select an appropriate Polar Class.

3.11.1.2.2 The Polar Class notation is used throughout this Chapter Requirements for Polar Class ships to convey the differences between classes with respect to operational capability and strength.

3.11.1.3 Upper and Lower Ice Waterlines.

3.11.1.3.1 *The upper ice waterline* – a line enveloping the highest points of the waterline at which the ship will navigate in the ice. Such a line enveloping the indicated points may be a broken line.

The lower ice waterline - a line enveloping the lowest points of the waterline at which the ship will navigate in the ice. Such a line enveloping the indicated points may be a broken line.

3.11.1.3.2 The upper and lower ice waterlines upon which the design of the ship has been based is to be indicated in the Certificate of Classification. The upper ice waterline (UIWL) is to be defined by the maximum draughts fore, amidships and aft. The lower ice waterline (LIWL) is to be defined by the minimum draughts fore, amidships and aft.

3.11.1.3.3 The lower ice waterline is to be determined with due regard to the ship’s ice-going capability in the ballast loading conditions. The propeller is to be fully submerged at the lower ice waterline.

3.11.2 STRUCTURAL REQUIREMENTS FOR POLAR CLASS SHIPS

3.11.2.1 Application.

3.11.2.1.1 The requirements of **3.11.2** apply to Polar Class ships according to **3.11.1**.

3.11.2.2 Hull areas.

3.11.2.2.1 The hull of Polar Class ships is divided into areas reflecting the magnitude of the loads that are expected to act upon them. In the longitudinal direction, there are four regions: Bow, Bow Intermediate, Midbody and Stern. The Bow Intermediate, Midbody and Stern regions are further divided in the vertical direction into the Bottom, Lower and Icebelt regions. The extent of each hull area is illustrated in Figure 3.11.2.2.1.

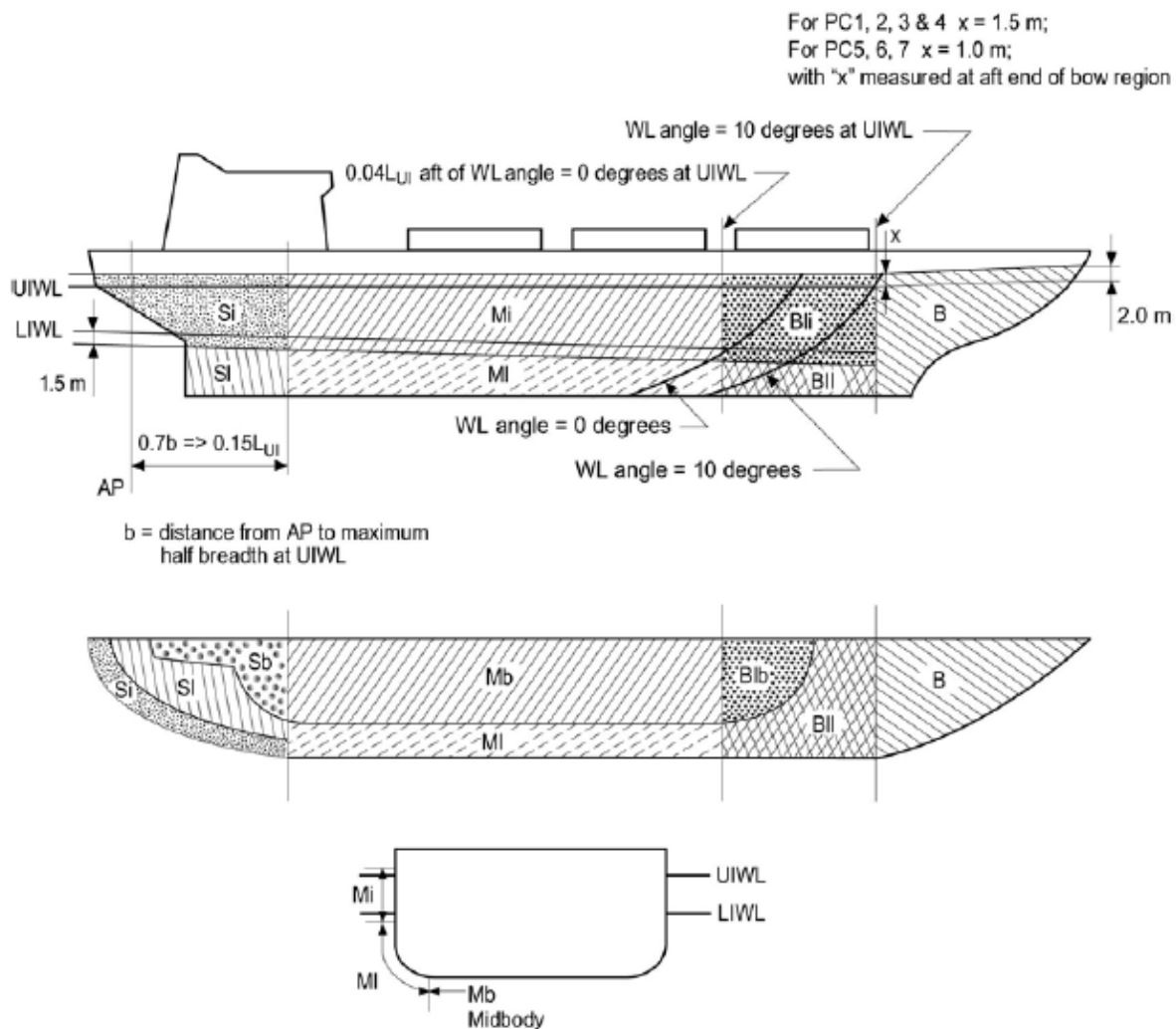

Fig.3.11.2.2.1 Hull area extents

3.11.2.2.2 The upper ice waterline (UIWL) and lower ice waterline (LIWL) are as defined in **3.11.1.3**.

3.11.2.2.3 3.11.2.2.1, notwithstanding, at no time is the boundary between the Bow and Bow Intermediate regions to be forward of the intersection point of the line of the stem and the ship baseline.

3.11.2.2.4 Figure 3.11.2.2.1, notwithstanding, the aft boundary of the Bow region need not be more than $0.45 L_{UI}$ aft of the fore side of the stem at the intersection with the upper ice waterline (UIWL).

3.11.2.2.5 The boundary between the bottom and lower regions is to be taken at the point where the shell is inclined 7° from horizontal.

3.11.2.2.6 If a ship is intended to operate astern in ice regions, the aft section of the ship is to be designed using the Bow and Bow Intermediate hull area requirements.

3.11.2.2.7 If the ship is assigned the additional notation "Icebreaker", the forward boundary of the stern region is to be at least $0.04 L_{UI}$ forward of the section where the parallel ship side at the upper ice waterline (UIWL) ends.

3.11.2.3 Design ice loads.

3.11.2.3.1 General.

3.11.2.3.1.1 A glancing impact on the bow is the design scenario for determining the scantlings required to resist ice loads.

3.11.2.3.1.2 The design ice load is characterized by an average pressure (P_{avg}) uniformly distributed over a rectangular load patch of height (b) and width (w).

3.11.2.3.1.3 Within the Bow area of all Polar Class ships, and within the Bow Intermediate Icebelt area of Polar Class **PC6** and **PC7**, the ice load parameters are functions of the actual bow shape. To determine the ice load parameters (P_{avg} , b and w), it is required to calculate the following ice load characteristics for sub-regions of the bow area; shape coefficient (f_{ai}), total glancing impact force (F_i), line load (Q_i) and pressure (P_i).

3.11.2.3.1.4 In other ice-strengthened areas, the ice load parameters (P_{avg} , b_{NonBow} and w_{NonBow}) are determined independently of the hull shape and based on a fixed load patch aspect ratio, $AR = 3.6$.

3.11.2.3.1.5 Design ice forces calculated according to **3.11.2.3.2.1.1**, are applicable for bow forms where the buttock angle γ at the stem is positive and less than 80 deg, and the normal frame angle β' at the centre of the foremost sub-region, as defined in **3.11.2.3.2.1**, is greater than 10 deg.

3.11.2.3.1.6 Design ice forces calculated according to **3.11.2.3.2.1.2**, are applicable for ships which are assigned the Polar Class **PC6** or **PC7** and have a bow form with vertical sides. This includes bows where the normal frame angles β' at the considered sub-regions, as defined in **3.11.2.3.2.1**, are between 0 and 10 deg.

3.11.2.3.1.7 For ships which are assigned the Polar Class **PC6** or **PC7**, and equipped with bulbous bows, the design ice forces on the bow are to be determined according to **3.11.2.3.2.1.2**. In addition, the design forces are not to be taken less than those given in **3.11.2.3.2.1.1** assuming

$$f_a = 0,6 \text{ and } AR = 1,3.$$

3.11.2.3.1.8 For ships with bow forms other than those defined in **3.11.2.3.1.5** – **3.11.2.3.1.7**, design forces are to be specially considered by the Register.

3.11.2.3.1.9 Ship structures that are not directly subjected to ice loads may still experience inertial loads of stowed cargo and equipment resulting from ship/ice interaction. These inertial loads, based on accelerations determined by the Register, are to be considered in the design of these structures.

3.11.2.3.2 Glancing impact load characteristics.

The parameters defining the glancing impact load characteristics are reflected in the Class Factors listed in Table 3.11.2.3.2-1 and Table 3.11.2.3.2-2.

Table 3.11.2.3.2-1 Class factors to be used in 3.11.2.3.2.1

Polar Class	Crushing failure Class Factor CF_C	Flexural failure Class Factor CF_F	Load patch dimensions Class Factor CF_D	Displacement Class Factor CF_{DIS}	Longitudinal strength Class Factor CF_L
1	2	3	4	5	6
PC1	17,69	68,6	2,01	250	7,46
PC2	9,89	46,8	1,75	210	5,46
PC3	6,06	21,17	1,53	180	4,17
PC4	4,50	13,48	1,42	130	3,15
PC5	3,10	9,00	1,31	70	2,50
PC6	2,40	5,49	1,17	40	2,37
PC7	1,80	4,06	1,11	22	1,81

Table 3.11.2.3.2-2 Class factors to be used in 3.11.2.3.2.2

Polar Class	Crushing failure Class Factor CF_C	Line load Class Factor CF_{QV}	Pressure Class Factor CF_{PV}
PC6	3,43	2,82	0,65
PC7	2,60	2,33	0,65

3.11.2.3.2.1 Bow area.

In the Bow area, the force (F), line load (Q), pressure (P) and load patch aspect ratio (AR) associated with the glancing impact load scenario are functions of the hull angles measured at the upper ice waterline (UIWL). The influence of the hull angles is captured through calculation of a bow shape coefficient (f_a). The hull angles are defined in Figure 3.11.2.3.2.1.

The waterline length of the bow region is generally to be divided into 4 sub-regions of equal length. The force (F), line load (Q), pressure (P) and load patch aspect ratio (AR) are to be calculated with respect to the mid-length position of each sub-region (each maximum of F , Q and P is to be used in the calculation of the ice load parameters P_{avg} , b and w).

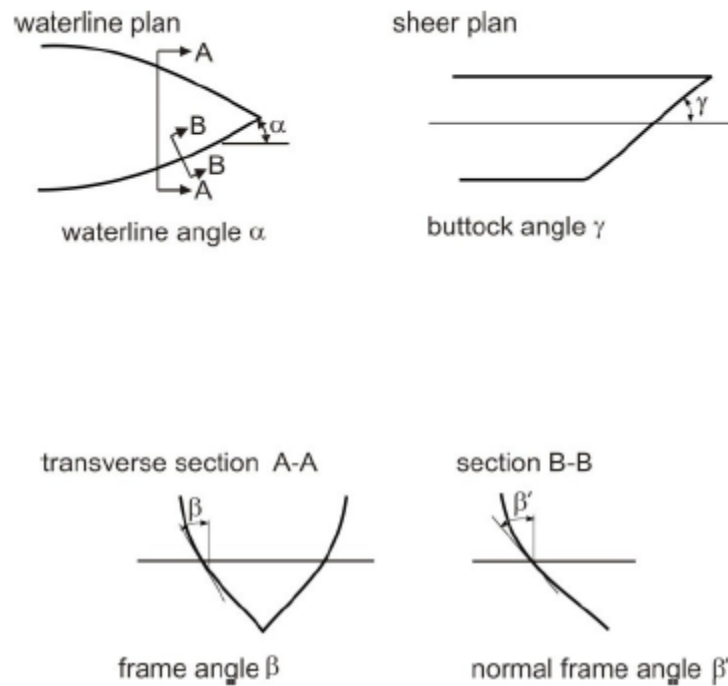

Definition of hull angles

Fig. 3.11.2.3.2.1

Note: β' = normal frame angle at upper ice waterline [deg]

α = upper ice waterline angle [deg]

γ = buttock angle at upper ice waterline (angle of buttock line measured from horizontal) [deg] $\tan(\beta) = \tan(\alpha)/\tan(\gamma)$

$\tan(\beta') = \tan(\beta)\cos(\alpha)$

3.11.2.3.2.1.1 The Bow area load characteristics for bow forms defined in **3.11.2.3.1.5**, are determined as follows::

Shape coefficient f_{ai} :

$$f_{ai} = \min(f_{ai,1}; f_{ai,2}; f_{ai,3}), \quad (3.11.2.3.2.1.1-1)$$

$$f_{ai,1} = [0,097 - 0,68 \cdot (x/L - 0,15)^2] \cdot \alpha_i / (\beta'_i)^{0,5};$$

$$f_{ai,2} = 1,2CF_F / [(\sin(\beta'_i) \cdot CF_C \cdot \Delta^{0,64})];$$

$$f_{ai,3} = 0,60;$$

Force F , in MN:

$$F_i = f_{ai} \cdot CF_C \cdot \Delta^{0,64}, \quad (3.11.2.3.2.1.1-2)$$

Load patch aspect ratio AR :

$$AR = 7,46 \cdot \sin(\beta'_i) \geq 1,3, \quad (3.11.2.3.2.1.1-3)$$

Line load Q , in MN/m:

$$Q_i = F_i^{0,61} CF_D / AR_i^{0,35}, \quad (3.11.2.3.2.1.1-4)$$

Pressure P , in MPa:

$$P_i = F_i^{0,22} CFD2 AR_i^{0,3}, \quad (3.11.2.3.2.1.1-5)$$

where: i - sub-region considered;

L – length, in m, as defined in 1.1.3, measured along *UIWL*;

x - distance from the fore side of the stem at the intersection with the upper ice waterline (*UIWL*) to station under consideration;

α - waterline angle in deg., (refer to Fig. 3.11.2.3.2.1);

β' - normal frame angle in deg., (refer to Fig. 3.11.2.3.2.1);

Δ - displacement, not to be taken less than 5 kt;

CF_C – Crushing failure Class Factor from Table 3.11.2.3.2-1;

CF_F - Flexural failure Class Factor from Table 3.11.2.3.2-1;

CF_D - Load patch dimensions Class Factor from Table 3.11.2.3.2-1.

3.11.2.3.2.1.2 The Bow area load characteristics for bow forms defined in 3.11.2.3.1.6 are determined as follows:

Shape coefficient f_{ai} :

$$f_{ai} = \alpha_i / 30; \quad (3.11.2.3.2.1.2-1)$$

Force F , in MN:

$$F_i = f_{ai} \cdot CF_{CV} \cdot \Delta^{0,47}, \quad (3.11.2.3.2.1.2-2)$$

Line load Q , in MN/m:

$$Q_i = F_i^{0,22} CF_{QV}, \quad (3.11.2.3.2.1.2-3)$$

Pressure P , in MPa:

$$P_i = F_i^{0,56} CF_{PV}, \quad (3.11.2.3.2.1.2-4)$$

where: i – part of bow area which are considered;

α - waterline angle in deg., (refer to Fig. 3.11.2.3.2.1);

Δ - displacement, not to be taken less than 5 kt;

CF_{CV} – Crushing failure Class Factor from Table 3.11.2.3.2-2;

CF_{QV} - Line load Class Factor from Table 3.11.2.3.2-2;

CF_{PV} - Pressure Class Factor from Table 3.11.2.3.2-2.

3.11.2.3.2.2 Hull areas other than the bow.

In the hull areas other than the bow, the force F_{NonBow} , in MN and line load Q_{NonBow} , in MN/m, used in the determination of the load patch dimensions b_{NonBow} and w_{NonBow} , and design pressure P_{avg} , are determined as follows:

$$F_{NonBow} = 0,36 CF_C DF; \quad (3.11.2.3.2.2-1)$$

$$Q_{NonBow} = 0,639 F_{NonBow} CF_D, \quad (3.11.2.3.2.2-2)$$

where: CF_C - Crushing failure Class Factor from Table 3.11.2.3.2-1;

DF - ship displacement factor:

$$DF = \Delta^{0,64} \text{ if } \Delta \leq CF_{DIS};$$

$$DF = CF_{DIS}^{0,64} + 0,1 \cdot (\Delta - CF_{DIS}) \text{ if } \Delta > CF_{DIS};$$

Δ - displacement, not to be taken less than 10 kt;

CF_{DIS} - Displacement Class Factor from Table 3.11.2.3.2-1.

3.11.2.3.3 Design load patch.

In the Bow area, and the Bow Intermediate Icebelt area for ships with class notation **PC6** and **PC7**, the design load patch has dimensions of width, w_{Bow} , in m, and height b_{Bow} , in m, defined as follows:

$$w_{Bow} = F_{Bow}/Q_{Bow}; \quad (3.11.2.3.3-1)$$

$$b_{Bow} = Q_{Bow}/P_{Bow}, \quad (3.11.2.3.3-2)$$

where: F_{Bow} - maximum force F_i , in MN, in the Bow area as defined in 3.11.2.3.2.1;

Q_{Bow} - maximum line load Q_i , in MN/m, in the Bow area as defined in 3.11.2.3.2.1;

P_{Bow} - maximum pressure P_i , in MPa, in the Bow area as defined in 3.11.2.3.2.1.

In hull areas of ice strengthening the design load patch has dimensions of width w_{NonBow} , in m, and height b_{NonBow} , in m, defined as follows:

$$w_{NonBow} = F_{NonBow}/Q_{NonBow}; \quad (3.11.2.3.3.2-1)$$

$$b_{NonBow} = w_{NonBow}/3,6, \quad (3.11.2.3.3.2-2)$$

where: F_{NonBow} - force as defined in 3.11.2.3.2.2;

Q_{NonBow} - line load as defined in 3.11.2.3.2.2.

3.11.2.3.4 Pressure within the design load patch.

3.11.2.3.4.1 The average pressure P_{avg} , in MPa, within a design load patch is determined as follows:

$$P_{avg} = F/(b \cdot w), \quad (3.11.2.3.4.1)$$

where: F - F_{Bow} or F_{NonBow} as appropriate for the hull area under consideration, in MN;

b - b_{Bow} or b_{NonBow} as appropriate for the hull area under consideration, in m;

w - w_{Bow} or w_{NonBow} as appropriate for the hull area under consideration, in m.

3.11.2.3.4.2 Areas of higher, concentrated pressure exist within the load patch. In general, smaller areas have higher local pressures. Accordingly, the peak pressure factors listed in Table 3.11.2.3.4.2 are used to account for the pressure concentration on localized structural members.

Table 3.11.2.3.4.2 Peak Pressure Factors

Structural member		Peak Pressure Factor PPF_i
Plating	Transversely-framed	$PPF_p = (1,8 - s) \geq 1,2$
	Longitudinally-framed	$PPF_p = (2,2 - 1,2s) \geq 1,5$
Frames in transverse framing systems	With load distributing stringers	$PPF_t = (1,6 - s) \geq 1,0$
	With no load distributing stringers	$PPF_t = (1,8 - s) \geq 1,2$
Frames in bottom structures		$PPF_s = (1,6 - s) \geq 1,0$
Load carrying stringers		$PPF_s = 1,0$ if $S_w \geq 0,5w$
Side longitudinals		$PPF_s = 2 - 2S_w/w$ if $S_w < 0,5w$
Web frames		
where: s – frame or longitudinal spacing, in m;		
S_w – web frame spacing, in m;		
w – ice load patch width, in m.		

3.11.2.3.5 Hull area factors.

Associated with each hull area is an Area Factor that reflects the relative magnitude of the load expected in that area.

The Area Factor (AF) for each hull area is listed in Table 3.11.2.3.5-1.

In the event that a structural member spans across the boundary of a hull area, the largest hull area factor is to be used in the scantling determination of the member. Ships having propulsion arrangements with azimuth thruster(s) or “podded” propellers are to have specially considered Si , Sl and Sb hull area factors AF listed in Table 3.11.2.3.5-2.

Таблица 3.11.2.3.5-1 Hull Area Factors (AF)

Hull area		Area	Polar Class						
			PC1	PC2	PC3	PC4	PC5	PC6	PC7
Bow (B)	All	<i>B</i>	1,00	1,00	1,00	1,00	1,00	1,00	1,00
Bow Intermediate (BI)	Icebelt	<i>BIi</i>	0,90	0,85	0,85	0,80	0,80	1,00 ¹	1,00 ¹
	Lower	<i>BIl</i>	0,70	0,65	0,65	0,60	0,55	0,55	0,50
	Bottom	<i>BIb</i>	0,55	0,50	0,45	0,40	0,35	0,30	0,25
Midbody (M)	Icebelt	<i>Mi</i>	0,70	0,65	0,55	0,55	0,50	0,45	0,45
	Lower	<i>Ml</i>	0,50	0,45	0,40	0,35	0,30	0,25	0,25
	Bottom	<i>Mb</i>	0,30	0,30	0,25	²	²	²	²
Stern (S)	Icebelt	<i>Si</i>	0,75	0,70	0,65	0,60	0,50	0,40	0,35
	Lower	<i>Sl</i>	0,45	0,40	0,35	0,30	0,25	0,25	0,25
	Bottom	<i>Sb</i>	0,35	0,30	0,30	0,25	0,15	²	²

¹ refer to 3.11.2.3.1.3.
² Indicates that strengthening for ice loads is not necessary.

Table 3.11.2.3.5-2

Hull area		Area	Polar Class						
			PC1	PC2	PC3	PC4	PC5	PC6	PC7
Stern (S)	Icebelt	<i>Si</i>	0,90	0,85	0,80	0,75	0,65	0,55	0,50
	Lower	<i>Sl</i>	0,60	0,55	0,50	0,45	0,40	0,40	0,40
	Bottom	<i>Sb</i>	0,35	0,30	0,30	0,25	0,15	¹	¹

¹ Indicates that strengthening for ice loads is not necessary.

Hull Area Factors (AF) for ships with additional notation **Icebreaker** are listed in Table 3.11.2.3.5-3.

Table 3.11.2.3.5-3

Hull area		Area	Polar Class						
			PC1	PC2	PC3	PC4	PC5	PC6	PC7
Bow (B)	All	<i>B</i>	1,00	1,00	1,00	1,00	1,00	1,00	1,00
Bow Intermediate (BI)	Icebelt	<i>BIi</i>	0,90	0,85	0,85	0,85	0,85	1,00	1,00
	Lower	<i>BIl</i>	0,70	0,65	0,65	0,65	0,65	0,65	0,65
	Bottom	<i>BIb</i>	0,55	0,50	0,45	0,45	0,45	0,45	0,45
Midbody (M)	Icebelt	<i>Mi</i>	0,70	0,65	0,55	0,55	0,55	0,55	0,55
	Lower	<i>Ml</i>	0,50	0,45	0,40	0,40	0,40	0,40	0,40
	Bottom	<i>Mb</i>	0,30	0,30	0,25	0,25	0,25	0,25	0,25
Stern (S)	Icebelt	<i>Si</i>	0,95	0,90	0,80	0,80	0,80	0,80	0,80
	Lower	<i>Sl</i>	0,55	0,50	0,45	0,45	0,45	0,45	0,45
	Bottom	<i>Sb</i>	0,35	0,30	0,30	0,30	0,30	0,30	0,30

3.11.2.4 Shell plate requirements.

3.11.2.4.1 The required minimum shell plate thickness, t , is given by:

$$t = t_{\text{net}} + t_s, \quad (3.11.2.4.1)$$

where: t_{net} - plate thickness required to resist ice loads according to 3.11.2.4.2;
 t_s - corrosion and abrasion allowance according to 3.11.2.11, in mm.

3.11.2.4.2 The thickness of shell plating required to resist the design ice load, t_{net} , in mm, depends on the orientation of the framing.

In the case of transversely-framed plating ($\Omega \geq 70^\circ$), including all bottom plating, i.e. plating in hull areas **B1b**, **Mb** and **Sb**, the net thickness is given by:

$$t_{\text{net}} = 500s \cdot [(AF \cdot PPF_p \cdot P_{\text{avg}})/\sigma_y]^{0.5}/(1 + s/2b). \quad (3.11.2.4.2-1)$$

In the case of longitudinally-framed plating ($\Omega \leq 20^\circ$), when $b \geq s$, the net thickness is given by:

$$t_{\text{net}} = 500s \cdot [(AF \cdot PPF_p \cdot P_{\text{avg}})/\sigma_y]^{0.5}/(1 + s/2l). \quad (3.11.2.4.2-2)$$

In the case of longitudinally-framed plating ($\Omega \leq 20^\circ$), when $b < s$, the net thickness is given by:

$$t_{\text{net}} = 500s \cdot [(AF \cdot PPF_p \cdot P_{\text{avg}})/\sigma_y]^{0.5} \cdot [2b/s - (b/s)^2]^{0.5}/(1 + s/2l), \quad (3.11.2.4.2-3)$$

where: Ω - smallest angle between the chord of the waterline and the line of the first level framing as illustrated in Figure 3.11.2.4.2, in deg.;

s - transverse frame spacing in transversely-framed ships or longitudinal frame spacing in longitudinally-framed ships, in m;

AF - Hull Area Factor as defined in 3.11.2.3.5;

PPF_p - Peak Pressure Factor from Table 3.11.2.3.4.2;

P_{avg} - average patch pressure as defined in 3.11.2.3.4.1, in MPa;

σ_y - minimum upper yield stress of the material, in N/mm²;

b - height of design load patch [m], where b is to be taken not greater than $b \leq l - s/4$;

l - distance between frame supports, i.e. equal to the frame span as given in 3.11.2.5.5, but not reduced for any fitted end brackets, in m. When a load-distributing stringer is fitted, the length l need not be taken larger than the distance from the stringer to the most distant frame support.

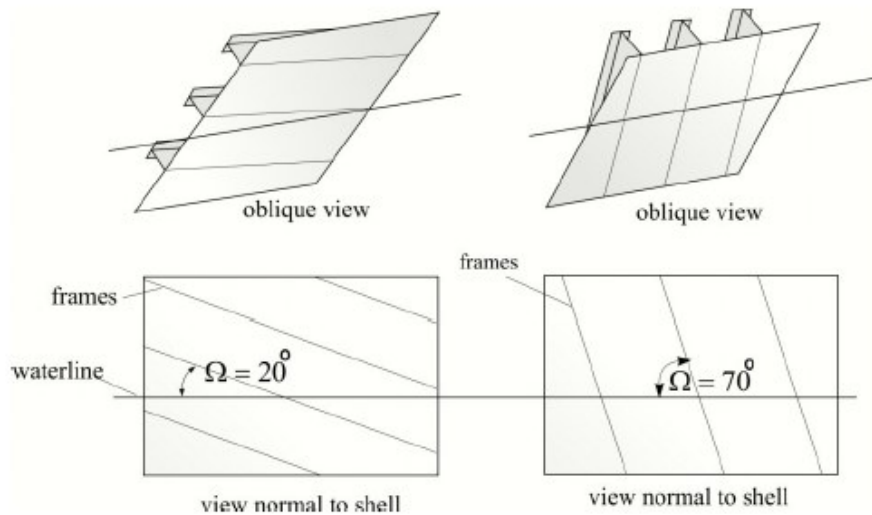

Fig. 3.11.2.4.2
Shell framing angle Ω

In case $20^\circ < \Omega < 70^\circ$, net thickness of plating is determined by the linear interpolation.

3.11.2.5 Framing - General.

3.11.2.5.1 Framing members of Polar Class ships are to be designed to withstand the ice loads defined in 3.11.2.3.

3.11.2.5.2 The term “framing member” refers to transverse and longitudinal local frames, loadcarrying stringers and web frames in the areas of the hull exposed to ice pressure, (refer to Fig. 3.11.2.2.1).

3.11.2.5.3 The strength of a framing member is dependent upon the fixity that is provided at its supports. Fixity can be assumed where framing members are either continuous through the support or attached to a supporting section with a connection bracket. In other cases, simple support is to be assumed unless the connection can be demonstrated to provide significant rotational restraint. Fixity is to be ensured at the support of any framing which terminates within an ice-strengthened area.

3.11.2.5.4 The details of framing member intersection with other framing members shall be in accordance with **3.10.2.4.5**.

Details for securing the ends of framing members at supporting sections, are to be in accordance with **1.7.2.2** and **2.5.5**.

3.11.2.5.5 The effective span of a framing member is to be determined on the basis of its moulded length. If brackets are fitted, the effective span may be reduced in accordance with **3.10.2.2.3**.

Brackets are to be configured to ensure stability in the elastic and post-yield response regions.

3.11.2.5.6 When calculating the section modulus and shear area of a framing member, net thicknesses of the web, flange (if fitted) and attached shell plating are to be used.

The shear area of a framing member may include that material contained over the full depth of the member, i.e. web area including portion of flange, if fitted, but excluding attached shell plating.

3.11.2.5.7 The actual net effective shear area A_w , in cm^2 , of a transverse or longitudinal local frame is given by:

$$A_w = ht_{wn}\sin\varphi_w/100, \quad (3.11.2.5.7)$$

where: h - height of stiffener, in mm, see Figure 3.11.2.5.7;

t_{wn} - net web thickness, in mm;

$t_{wn} = t_w - t_c$;

t_w - as built web thickness, in mm, see Figure 3.11.2.5.7;

t_c - corrosion deduction [mm] to be subtracted from the web and flange thickness;

t_c is specified in accordance with **1.1.5.2**, but not less than as required by **3.11.2.11.3**;

φ_w - smallest angle between shell plate and stiffener web, measured at the midspan of the stiffener, (see Figure 3.11.2.5.7). The angle φ_w may be taken as 90 deg provided the smallest angle is not less than 75 deg.

3.11.2.5.8 When the cross-sectional area of the attached plate flange exceeds the cross-sectional area of the local frame, the actual net effective plastic section modulus, Z_p , in mm, of a transverse or longitudinal frame is given by:

$$Z_p = A_{pn}t_{pn}/20 + h^2_w t_{wn} \sin\varphi_w / 2000 + A_{fn} (h_{fc} \sin\varphi_w - b_w \cos\varphi_w) / 10, \quad (3.11.2.5.8-1)$$

where: h , t_{wn} , t_c i φ_w - refer to **3.11.2.5.7**, and s - as defined in **3.11.2.4.2**;

A_{pn} - net cross-sectional area of the local frame, in cm^2 ;

t_{pn} - fitted net shell plate thickness, in mm, complying with t_{net} as required by **3.11.2.4.2**;

h_w - height of local frame web, in mm, (see Figure 3.11.2.5.7);

A_{fn} - net cross-sectional area of local frame flange, in cm^2 ;

h_{fc} - height of local frame measured to centre of the flange area, in mm, (see Figure 3.11.2.5.7);

b_w - distance from mid thickness plane of local frame web to the centre of the flange area, in mm, (see Figure 3.11.2.5.7).

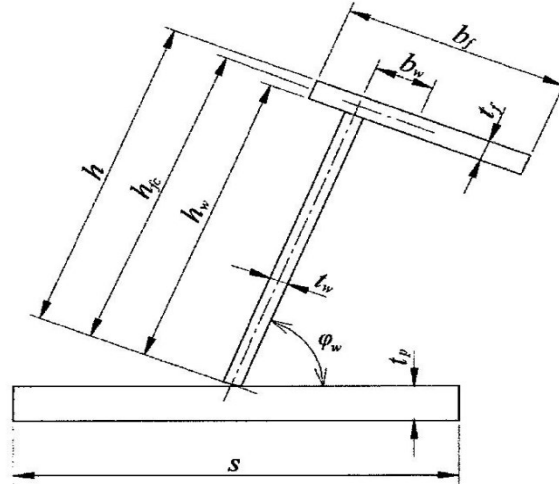

Fig. 3.11.2.5.7
Stiffener geometry

When the cross-sectional area of the local frame exceeds the cross-sectional area of the attached plate flange, the plastic neutral axis is located a distance z_{na} above the attached shell plate, given by:

$$z_{na} = (100A_{fn} + ht_{wn} - 1000t_{pn}s) / 2t_{wn}, \quad (3.11.2.5.8-2)$$

When the cross-sectional area of the attached plate flange exceeds the cross-sectional area of the local frame, the actual net effective plastic section modulus, Z_p , of a transverse or longitudinal frame is given by:

$$Z_p = t_{pn}s \cdot (z_{na} + t_{pn}/2) \cdot \sin\phi_w + \{[(h_w - z_{na})^2 + z_{na}^2] \cdot t_{wn}\sin\phi_w/2 + A_{fn} \cdot [(h_{fc} - z_{na}) \cdot \sin\phi_w - b_w\cos\phi_w]/10\}. \quad (3.11.2.5.8-3)$$

3.11.2.5.9 In the case of oblique framing arrangement $20^\circ < \Omega < 70^\circ$, deg, where Ω is defined as given in **3.11.2.4.2**, linear interpolation is to be used.

3.11.2.6 Framing - Local frames in bottom structures and transverse local frames in side structures.

3.11.2.6.1 The local frames in bottom structures (i.e. hull areas B_{lb} , M_b and S_b) and transverse local frames in side structures are to be dimensioned such that the combined effects of shear and bending do not exceed the plastic strength of the member. The plastic strength is defined by the magnitude of midspan load that causes the development of a plastic collapse mechanism.

For bottom structure the patch load shall be applied with the dimension (b) parallel with the frame direction.

3.11.2.6.2 The actual net effective shear area of the frame, A_w , as defined in **3.11.2.5.7**, is to comply with the following condition: $A_w \geq A_t$, where:

$$A_t = 100^2 \cdot 0,5LL \cdot s \cdot (AF \cdot PPF \cdot P_{avg}) / (0,577\sigma_y), \quad (3.11.2.6.2)$$

where LL – length of loaded portion of span – lesser of a and b , in m;

a - local frame span as defined in **3.11.2.5.5**, in m;

b - height of design ice load patch as defined in **3.11.2.3.3**;

s - spacing of local frame, in m;

AF - Hull Area Factor from **3.11.2.3.5**;

PPF - Peak Pressure Factor, PPF_t or PPF_s as appropriate from Table 3.11.2.3.4.2;

P_{avg} – average pressure within load patch as defined in **3.11.2.3.4**;

σ_y - minimum upper yield stress of the material, in N/mm^2 .

3.11.2.6.3 The actual net effective plastic section modulus of the plate/stiffener combination, Z_p as defined in **3.11.2.5.8**, is to comply with the following condition: $Z_p \geq Z_{pt}$, where Z_{pt} , in cm^3 , is to be the greater

calculated on the basis of two load conditions: a) ice load acting at the midspan of the local frame, and b) the ice load acting near a support. The A_1 parameter defined below reflects these two conditions:

$$Z_{pt} = 100^3 \cdot LL \cdot Y \cdot s \cdot (AF \cdot PPF_t \cdot P_{avg}) \cdot a \cdot A_1 / (4\sigma_y), \quad (3.11.2.6.3)$$

where: AF , PPF_t , P_{avg} , LL , b , s , a and σ_y are as given in **3.11.2.6.2**;

$Y = 1 - 0,5 (LL/a)$;

A_1 – maximum of:

$A_{1A} = 1 / \{1 + j/2 + (k_w j/2) \cdot [(1 - a^2)^{0,5} - 1]\}$;

$A_{1B} = [1 - 1/(2a_1 \cdot Y)] / (0,275 + 1,44k_z^{0,7})$;

$j = 1$ for a local frame with one simple support outside the ice-strengthened areas;

$j = 2$ for a local frame without any simple supports;

$a_1 = A_t/A_w$;

A_t – minimum shear area of the local frame as given in **3.11.2.6.2**, in cm^2 ;

A_w – effective net shear area of the local frame (calculated according to **3.11.2.5.7**), in cm^2 ;

$k_w = 1 / (1 + 2A_{fm}/A_w)$, where A_{fm} as given in **3.11.2.5.8**;

$k_z = z_p/Z_p$, in general;

$k_z = 0$, when the frame is arranged with end bracket;

z_p = sum of individual plastic section moduli of flange and shell plate as fitted, in cm^3 ;

$z_p = (b_f \cdot t_{fm}^2/4 + b_{eff} \cdot t_{pn}^2/4)/1000$;

b_f – flange breadth, in mm, (see Figure 3.11.2.5.7);

t_{fm} – net flange thickness, in mm;

$t_{fm} = t_f - t_c$, (t_c as given in **3.11.2.5.7**);

t_f – as-built flange thickness, in mm, (see Figure 3.11.2.5.7);

t_{pn} – the fitted net shell plate thickness, in mm, (not to be less than t_{net} as given in **3.11.2.4**);

b_{eff} – effective width of shell plate flange, in mm;

$b_{eff} = 500s$;

Z_p – net effective plastic section modulus of the local frame (calculated according to **3.11.2.5.8**), in cm^3 .

3.11.2.6.4 The scantlings of the local frame are to meet the structural stability requirements of **3.11.2.9**.

3.11.2.7 Framing - Longitudinal local frames in side structures.

3.11.2.7.1 Longitudinal local frames in side structures are to be dimensioned such that the combined effects of shear and bending do not exceed the plastic strength of the member.

The plastic strength is defined by the magnitude of midspan load that causes the development of a plastic collapse mechanism.

3.11.2.7.2 The actual net effective shear area of the frame, A_w , as defined in **3.11.2.5.7**, is to comply with the following condition: $A_w \geq A_L$, where:

$$A_L = 100^2 \cdot (AF \cdot PPF_s \cdot P_{avg}) \cdot 0,5b_1a / (0,577\sigma_y), \text{ in } \text{cm}^2, \quad (3.11.2.7.2)$$

where: AF – Hull Area Factor from **3.11.2.3.5**;

PPF_s – Peak Pressure Factor from Table **3.11.2.3.4.2**;

P_{avg} – average pressure within load patch as defined in **3.11.2.3.4**;

$b_1 = k_0b_2$, in m;

$k_0 = 1 - 0,3/b'$;

$b' = b/s$;

b – height of design ice load patch as defined in **3.11.2.3.3**;

s – spacing of longitudinal frames, in m;

$b_2 = b(1 - 0,25b')$, in m, if $b' < 2$;

$b_2 = s$, in m, if $b' \geq 2$;

a – effective span of longitudinal local frame as given in **3.11.2.5.5**;

σ_y – minimum upper yield stress of the material, in N/mm^2 .

3.11.2.7.3 The actual net effective plastic section modulus of the plate/stiffener combination, Z_p as defined in **3.11.2.5.8**, is to comply with the following condition: $Z_p \geq Z_{pL}$, where:

$$Z_{pL} = 100^3 \cdot (AF \cdot PPF_s \cdot P_{avg}) \cdot b_1a^2A_4/8\sigma_y, \text{ in } \text{cm}^3, \quad (3.11.2.7.3)$$

where: AF , PPF_s , P_{avg} , b_1 , a and σ_y are as given in 3.11.2.7.2;

$$A_4 = 1/\{2 + k_{wl} \cdot [(1 - a^2)^{0.5} - 1]\};$$

$$a_4 = A_l/A_w;$$

A_L - minimum shear area for longitudinal as given in 3.11.2.7.2, in cm^2 ;

A_w - net effective shear area of longitudinal (calculated according to 3.11.2.5.7), in cm^2 ;

$$k_{wl} = 1/(1 + 2A_{fl}/A_w), \text{ where } A_{fl} \text{ as given in 3.11.2.5.8.}$$

3.11.2.7.4 The scantlings of the longitudinals are to meet the structural stability requirements of 3.11.2.9.

3.11.2.8 Framing - Web frames and load carrying stringers.

3.11.2.8.1 Web frames and load-carrying stringers are to be designed to withstand the ice load patch as defined in 3.11.2.3. The load patch is to be applied at locations where the capacity of these members under the combined effects of bending and shear is minimised.

3.11.2.8.2 Web frames and load-carrying stringers are to be dimensioned such that the combined effects of shear and bending do not exceed the limit state(s).

Where the structural configuration is such that members do not form part of a grillage system, the appropriate peak pressure factor (PPF) from Table 3.11.2.3.4.2 is to be used. Shear capacity in way of lightening holes and cutouts in way of intersecting members shall comply with 3.10.2.4.8.

3.11.2.8.3 For determination of scantlings of load carrying stringers, web frames supporting local frames, or web frames supporting load carrying stringers forming part of a structural grillage system, appropriate methods as outlined in 3.11.2.17 are normally to be used.

3.11.2.8.4 The scantlings of web frames and load-carrying stringers are to meet the structural stability requirements of 3.11.2.9.

3.11.2.9 Framing - Structural stability.

3.11.2.9.1 To prevent local buckling in the web, the ratio of web height h_w to net web thickness t_{wn} of any framing member is not to exceed:

For flat bar sections:

$$h_w/t_{wn} \leq 282/\sigma_y^{0.5}; \quad (3.11.2.9.1-1)$$

For bulb, tee and angle sections:

$$h_w/t_{wn} \leq 805/\sigma_y^{0.5}, \quad (3.11.2.9.1-2)$$

where: h_w - web height, in mm;

t_{wn} - net web thickness, in mm;

σ_y - minimum upper yield stress of the material, in N/mm^2 .

3.11.2.9.2 Framing members for which it is not practicable to meet the requirements of 3.11.2.9.1 (e.g. load carrying stringers or deep web frames) are required to have their webs effectively stiffened. The scantlings of the web stiffeners are to ensure the structural stability of the framing member. The minimum net web thickness for these framing members is given by:

$$t_{wn} = 2,63 \cdot 10^{-3} c_1 \cdot \sqrt{\sigma_y/[5,34 + 4(c_1/c_2)^2]}, \quad (3.11.2.9.2)$$

where: $c_1 = h_w - 0,8h$, in mm;

h_w - web height of stringer / web frame, in mm, (see Figure 3.11.2.9.2);

h - height of framing member penetrating the member under consideration (0 if no such framing member), in mm (see Figure 3.11.2.9.2);

c_2 - spacing between supporting structure oriented perpendicular to the member under consideration, in mm, (see Figure 3.11.2.9.2);

σ_y - minimum upper yield stress of the material, in N/mm^2 .

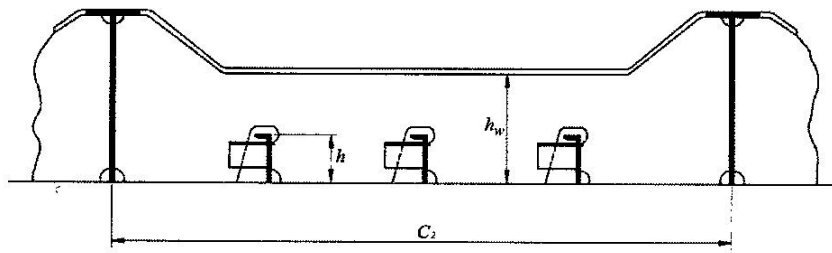

Fig. 3.11.2.9.2
Parameter definition of web stiffening

3.11.2.9.3 In addition, the following is to be satisfied:

$$t_{wn} \geq 0,35t_{pn} \cdot (\sigma_y/235)^{0,5}, \quad (3.11.2.9.3)$$

where: σ_y - minimum upper yield stress of the material, in N/mm²;

t_{wn} - net thickness of the web, in mm;

t_{pn} - net thickness of the shell plate in way of the framing member, in mm.

3.11.2.9.4 To prevent local flange buckling of welded profiles, the following are to be satisfied:

.1 The flange width, b_f , in mm, is not to be less than five times the net thickness of the web, t_{wn} ;

.2 The flange outstand, b_{out} , in mm, is to meet the following requirement:

$$b_{out}/t_{fn} \leq 155/\sigma_y^{0,5}, \quad (3.11.2.9.4.2)$$

where: t_{fn} - net thickness of flang, in mm;

σ_y - minimum upper yield stress of the material, in N/mm².

3.11.2.10 Plated structures.

3.11.2.10.1 Plated structures are those stiffened plate elements in contact with the hull and subject to ice loads. These requirements are applicable to an inboard extent which is the lesser of:

.1 web height of adjacent parallel web frame or stringer; or

.2 2.5 times the depth of framing that intersects the plated structure.

3.11.2.10.2 The thickness of the plating and the scantlings of attached stiffeners are to be such that the degree of end fixity necessary for the shell framing is ensured.

3.11.2.10.3 The stability of the plated structure is to adequately withstand the ice loads defined in 3.11.2.3.

3.11.2.11 Corrosion/abrasion additions and steel renewal.

3.11.2.11.1 Effective protection against corrosion and ice-induced abrasion is recommended for all external surfaces of the shell plating.

3.11.2.11.2 The values of corrosion/abrasion additions, t_s , to be used in determining the shell plate thickness are listed in Table 3.11.2.11.2.

Table 3.11.2.11.2

Hull area	t_s , in mm					
	With effective protection			Without effective protection		
	PC1- PC3	PC4, PC5	PC6, PC7	PC1- PC3	PC4, PC5	PC6, PC7
Bow; Bow Intermediate Icebelt	3,5	2,5	2,0	7,0	5,0	4,0
Bow Intermediate Lower; Midbody & Stern Icebelt	2,5	2,0	2,0	5,0	4,0	3,0
Midbody & Stern Lower; Bottom	2,0	2,0	2,0	4,0	3,0	2,5

3.11.2.11.3 The allowance for wear of the structures inside the casing that fall in the area of ice reinforcements, including sheet metal structures, walls and girders of the set, should not be less than $t_s = 1.0$ mm.

3.11.2.11.4 When the gauged thickness is less than $t_{net} + 0,5$ mm, steel renewal for ice strengthened structures is required, where for t_{net} – refer to 3.11.2.4.2.

3.11.2.12 Materials.

3.11.2.12.1 Steel grades of plating for hull structures are to be not less than those given in Table 3.11.2.12.4 and **3.11.2.12.5** based on the as-built thickness, the Polar Class and the material class of structural members according to **3.11.2.12.2**.

3.11.2.12.2 Material classes specified in Table 1.2.3.7-1 are applicable to Polar Class ships regardless of the ship's length. In addition, material classes for weather and sea exposed structural members and for members attached to the weather and sea exposed plating are given in Table 3.11.2.12.2

Where the material classes in Table 1.2.3.7-1 and those in Table 3.11.2.12.2 differ, the higher material class is to be applied.

Table 3.11.2.12.2 Material classes for structural members

Structural members	Material class
1	2
Shell plating within the bow and bow intermediate icebelt hull areas (B, BII).	II
All weather and sea exposed SECONDARY and PRIMARY, as defined in Table 1.2.3.7-1 structural members outside $0.4 L_{UL}$ amidships	I
Plating materials for stem and stern frames, rudder horn, rudder, propeller nozzle, shaft brackets, ice skeg, ice knife and other appendages subject to ice impact loads	II
All inboard framing members attached to the weather and sea-exposed plating, including any contiguous inboard member within 600 mm of the plating	I
Weather-exposed plating and attached framing in cargo holds of ships which by nature of their trade have their cargo hold hatches open during cold weather operations	I
All weather and sea exposed SPECIAL, as defined in Table 1 of UR S6.1, structural members within $0,2L$ from FP	II

3.11.2.12.3 Steel grades for all plating and attached framing of hull structures and appendages situated below the level of 0.3 m below the lower waterline, as shown in Figure 3.11.2.12.3, are to be obtained from Table 1.2.3.7-2 based on the material class for structural members in Table 3.11.2.12.2 above.

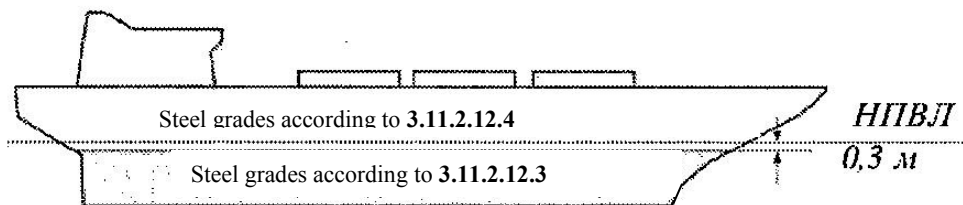

Fig. 3.11.2.12.3

Steel grade requirements for submerged and weather exposed shell plating

3.11.2.12.4 Steel grades for all weather exposed plating of hull structures and appendages situated above the level of 0.3 m below the lower ice waterline, as shown in 3.11.2.12.3, are to be not less than given in Table 3.11.2.12.4.

Table 3.11.2.12.4 Steel grades for weather exposed plating

Thickness t , in mm	Material class I				Material class II				Material class III					
	PC1÷PC5		PC6, PC7		PC1÷PC5		PC6, PC7		PC1÷PC3		PC4, PC5		PC6, PC7	
	MS	HT	MS	HT	MS	HT	MS	HT	MS	HT	MS	HT	MS	HT
$t \leq 10$	B	AH	B	AH	B	AH	B	AH	E	EH	E	EH	B	AH
$10 < t \leq 15$	B	AH	B	AH	D	DH	B	AH	E	EH	E	EH	D	DH
$15 < t \leq 20$	D	DH	B	AH	D	DH	B	AH	E	EH	E	EH	D	DH
$20 < t \leq 25$	D	DH	B	AH	D	DH	B	AH	E	EH	E	EH	D	DH
$25 < t \leq 30$	D	DH	B	AH	E	EH2	D	DH	E	EH	E	EH	E	EH
$30 < t \leq 35$	D	DH	B	AH	E	EH	D	DH	E	EH	E	EH	E	EH
$35 < t \leq 40$	D	DH	D	DH	E	EH	D	DH	F	FH	E	EH	E	EH
$40 < t \leq 45$	E	EH	D	DH	E	EH	D	DH	F	FH	E	EH	E	EH
$45 < t \leq 50$	E	EH	D	DH	E	EH	D	DH	F	FH	F	FH	E	EH

Notes: 1. Includes weather-exposed plating of hull structures and appendages, as well as their outboard framing members, situated above a level of 0.3 m below the lowest ice waterline.
2. Grades D, DH are allowed for a single strake of side shell plating not more than 1.8 m wide from 0.3 m below the lowest ice waterline.

3.11.2.12.5 Castings are to have properties, specified in XIII «Materials» consistent with the expected service temperature for the cast component.

3.11.2.13 Longitudinal strength.

3.11.2.13.1 Application.

3.11.2.13.1.1 A ramming impact on the bow is the design scenario for the evaluation of the longitudinal strength of the hull.

3.11.2.13.1.2 Intentional ramming is not considered as a design scenario for ships which are designed with vertical or bulbous bows. Hence the longitudinal strength requirements given in **3.11.2.13** is not to be considered for ships with stem angle γ_{stem} equal to or larger than 80 deg.

3.11.2.13.1.3 Ice loads are only to be combined with still water loads. The combined stresses are to be compared against permissible bending and shear stresses at different locations along the ship's length. In addition, sufficient local buckling strength is also to be verified.

3.11.2.13.2 Design vertical ice force at the bow.

3.11.2.13.2.1 The design vertical ice force at the bow, F_{IB} , is to be taken as:

$$F_{\text{IB}} = \min(F_{\text{IB},1}; F_{\text{IB},2}), \quad (3.11.2.13.2.1-1)$$

where: $F_{\text{IB},1} = 0,534K_1^{0,15} \sin^{0,2}(\gamma_{\text{stem}}) \cdot (\Delta K_h)^{0,5} \cdot CF_L$; (3.11.2.13.2.1-2)

$$F_{\text{IB},2} = 1,2CF_F; \quad (3.11.2.13.2.1-3)$$

K_1 - indentation parameter = K_f/K_h ;

.1 for the case of a blunt bow form: $K_f = [2C \cdot B^{1-e_b}/(1+e_b)]^{0,9} \text{tg}(\gamma_{\text{stem}})^{-0,9(1+e_b)}$;

.2 for the case of wedge bow form ($\alpha_{\text{stem}} < 80^\circ$), $e_b = 1$ and the above simplifies to:

$$K_f = [\text{tg}(\alpha_{\text{stem}})/\text{tg}^2(\gamma_{\text{stem}})]^{0,9};$$

$$K_h = 0,01A_{\text{wp}}, \text{ in MN/m};$$

CF_L - Longitudinal Strength Class Factor from Table 3.11.2.3.2.1;

e_b - bow shape exponent which best describes the waterplane (see Figures 3.11.2.13.2.1-1 and 3.11.2.13.2.1-2):

$e_b = 1,0$ for a simple wedge bow form;

$e_b = 0,4 - 0,6$ for a spoon bow form;

$e_b = 0$ for a landing craft bow form;

An approximate e_b , determined by a simple fit is acceptable;

γ_{stem} - stem angle to be measured between the horizontal axis and the stem tangent at the upper ice waterline [deg] (buttock angle as per Figure 3.11.2.3.2.1.1.1, measured on the centreline);

α_{stem} - waterline angle measured in way of the stem at the upper ice waterline, see Figure 3.11.2.13.2.1-1, in deg.;

$$C = 1/[2(L_B/B)^{e_b}];$$

B - moulded breadth corresponding to the upper ice waterline, in m;

L_B - bow length used in the equation $y = B/[2(x/L_B)^{e_b}]$, in m, (see Figures 3.11.2.13.2.1-1 and 3.11.2.13.2.1-2);

Δ - displacement as defined in I2.1.2.2, not to be taken less than 10 kt;

A_{wp} - waterplane area corresponding to the upper ice waterline, in m^2 ;

CF_F - Flexural Failure Class Factor from Table 3.11.2.3.2.1.

Where applicable, values dependent on draft shall be determined at the waterline level corresponding to the observed load case.

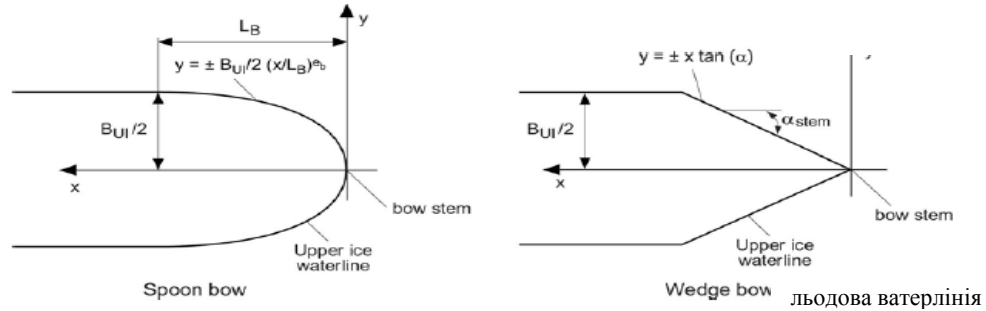

Fig. 3.11.2.13.2.1-1
Bow shape definition

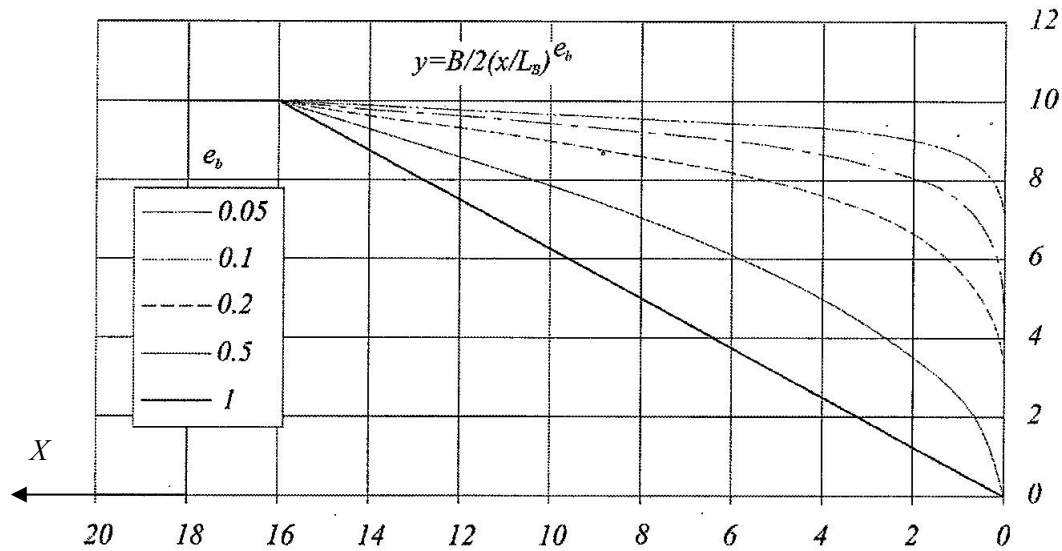

Fig. 3.11.2.13.2.1-1
Illustration of e_b effect on the bow shape for $B = 20$ m and $L_B = 16$ m

3.11.2.13.3 Design vertical shear force.

3.11.2.13.3.1 The design vertical ice shear force, F_I , along the hull girder is to be taken as:

$$F_I = C_f F_{IB}, \tag{3.11.2.13.3.1}$$

where: C_f - longitudinal distribution factor to be taken as follows:

Positive shear force

$C_f = 0.0$ between the aft end of L and $0.6L$ from aft;

$C_f = 1.0$ between $0.9 L$ from aft and the forward end of L ;

Negative shear force

$C_f = 0.0$ at the aft end of L ;

$C_f = -0.25$ between $0.0 L$ and $0.2 L$ from aft;
 $C_f = -0.5$ between $0.2 L$ and $0.6 L$ from aft;

$C_f = 2.5 x/L - 2$ в переписах $0.6 < x/L < 0.8$;

$C_f = 0.0$ between $0.8 L$ from aft and the forward end of L ;

x - distance of the calculated section from the aft perpendicular, in m;

L - length as defined in 1.1.3.

3.11.2.13.3.2 The applied vertical shear stress is to be determined along the hull girder in a similar manner as in 1.6.5.1 by substituting the design vertical ice shear force for the design vertical wave shear force.

3.11.2.13.4 Design vertical ice bending moment.

3.11.2.13.4.1 The design vertical ice bending moment, M_I , along the hull girder is to be taken as:

$$M_I = 0.1 C_m L \sin^{-0.2}(\gamma_{\text{stem}}) F_{IB}, \quad (3.11.2.13.4.1)$$

where: L - length as defined in 1.1.3;

γ_{stem} - is as given in 3.11.2.13.2.1;

F_{IB} - design vertical ice force at the bow, in MN;

C_m - longitudinal distribution factor for design vertical ice bending moment to be taken as follows:

$C_m = 0.0$ at the aft end of L ;

$C_m = 2.0x/L$ between $0.0 L$ and $0.5 L$ from aft;

$C_m = 1.0$ between $0.5L$ and $0.7L$ from aft;

$C_m = 2.96 - 2.8x/L$ between $0.7L$ and $0.95 L$ from aft;

$C_m = 0.3$ at $0.95 L$ from aft;

$C_m = 6.0 - 6.0x/L$ between 0.95 and $1.0 L$ from aft;

$C_m = 0.0$ at the forward end of L ;

x - distance of the calculated section from the aft perpendicular, in m.

Where applicable, values dependent on draft shall be determined at the waterline level corresponding to the observed load case.

3.11.2.13.4.2 The applied vertical bending stress, σ_a , is to be determined along the hull girder in a similar manner as in 1.6.5.1 by substituting the design vertical ice bending moment for the design vertical wave bending moment. The ship still water bending moment is to be taken as the permissible still water bending moment in sagging condition.

3.11.2.13.5 Longitudinal strength criteria.

3.11.2.13.5.1 The strength criteria provided in Table 3.11.2.13.5.1 are to be satisfied.

The design stress is not to exceed the permissible stress.

Table 3.11.2.13.5.1 Longitudinal strength criteria.

Failure mode	Applied stress	Permissible stress when $\sigma_y/\sigma_u \leq 0,7$	Permissible stress when $\sigma_y/\sigma_u > 0,7$
Tension	σ_a	$\eta\sigma_y$	$\eta \cdot 0,41 \cdot (\sigma_u + \sigma_y)$
Shear	τ_a	$\eta\sigma_y/3^{0,5}$	$\eta \cdot 0,41 \cdot (\sigma_u + \sigma_y)/3^{0,5}$
Buckling	σ_a	σ_c for plating and for web plating of stiffeners $\sigma_c/1,1$ for stiffeners	
	τ_a	τ_c	

where: σ_a = applied vertical bending stress [N/mm²];
 τ_a = applied vertical shear stress [N/mm²]
 σ_y = minimum upper yield stress of the material [N/mm²]
 σ_u = ultimate tensile strength of material [N/mm²]
 σ_c = critical buckling stress in compression, according to **1.6.5.3** [N/mm²]
 τ_c = critical buckling stress in shear, according to **1.6.5.3** [N/mm²]
 $\eta = 0,6$ for ships which are assigned the additional notation **Icebreaker**.

3.11.2.14 Stem and stern frames.

3.11.2.14.1 The stem of polar class ships shall be made of steel with a solid cross-section. The stem of polar class **PC1** and **PC2** ships and icebreakers, as well as stem and stern frame of icebreakers and **PC1**, **PC2**, **PC3**, **PC4** and **PC5** polar class ships shall be made of forged or cast steel. The use of stems and stern frames welded from separate cast or forged parts is allowed.

3.11.2.14.2 For **PC3**, **PC4**, **PC5**, **PC6**, **PC7** polar class ships and icebreakers of the polar classes weaker than **PC4** the use of combined (made of bar or bar with thick plates welded to it) or plate design stem is allowed. Welds of combined or plate design stems must be performed with full penetration in accordance with the requirements of part XIV "Welding". For **PC6** and **PC7** polar class ships the use of combined or plate design stem is allowed.

3.11.2.14.3 For **PC3**, **PC4**, **PC5**, **PC6**, **PC7** ice class ships, the stem shall, where practicable, be strengthened by a centre line web having its section depth equal to h_p at least (refer to Table 3.11.2.14.3) with a face plate along its free edge or a longitudinal bulkhead fitted on the ship centreline, on the entire stem length from the keel plate to the nearest deck or platform situated above the level *B* referred to in 3.11.2.2.1). The thickness of this plate shall not be less than that of the brackets with which the stem is strengthened (refer to **3.11.2.14.4**). In icebreakers and **PC1**, **PC2** ice class ships, a longitudinal bulkhead may be substituted for the centre line web.

Table 3.11.2.14.3

h_p , in m				
PC7	PC6	PC5	PC4	PC3
0,6	0,6	1,0	1,3	1,5

3.11.2.14.4 Within the vertical extent defined in **3.11.2.14.3**, the stem shall be strengthened by horizontal webs at least 0,6 m in depth and spaced not more than 0,6 m apart. The webs shall be carried to the nearest frames and connected thereto. In stems of combined or plate type, the webs shall be extended beyond the welded butts of the stem and shell plating.

Above the deck or platform located at a distance higher than the upper boundary of region B, the spacing of horizontal webs may gradually increase to 1,2 m in icebreakers and **PC1**, **PC2**, **PC3** ice class ships, and to 1,5 m in ships of other ice classes.

The web thickness shall be adopted not less than half the stem plate thickness according to **3.11.2.4.7**. The side stringers of the fore peak shall be connected to the webs fitted in line with them.

Side stringers in the fore peak shall be connected to the brackets installed in their plane.

In case of a full bow, vertical stiffeners may be required additionally to be fitted to the stem plates.

3.11.2.14.5 Where the stern frame has an appendage (ice knife), the clearance between the latter and the rudder plate shall not exceed 100 mm. The appendage shall be reliably connected to the stern frame. Securing the appendage to plate structures is not permitted.

3.11.2.14.6 In icebreakers, the lower edge of solepiece shall be constructed with a slope of 1:8 beginning from the propeller post.

3.11.2.14.7 The cross-sectional area A_{st} , in cm^2 , of the stem of any design shall not be less than determined by the formula:

$$A_{st} = c_t \cdot c_k \cdot f(\Delta), \quad (3.11.2.14.7-1)$$

where: $f(\Delta) = 31\Delta + 137$ with $\Delta < 5$ kt;

$f(\Delta) = 100 \cdot \Delta^{(2/3)}$ with $\Delta \geq 5$ kt;

Δ - displacement, in t;

c_t - 1,0 for polar class ships and 1,4 for icebreakers;

c_k - factor whose values shall be obtained from Table 3.11.2.14.7.

Table 3.11.2.14.7

c_k						
PC7	PC6	PC5	PC4	PC3	PC2	PC1
0,54	0,54	0,66	1,02	1,25	1,4	1,55

The section modulus Z_{st} , in cm^3 , of the stem cross-sectional area about an axis perpendicular to the centreline shall not be less than determined by the formula:

$$Z_{st} = 1,2 Q_{Bow}, \quad (3.11.2.14.7-2)$$

where: Q_{Bow} - linear load in accordance with 3.11.2.3.2.1, kN/m.

To be included in the design cross-sectional area of a combined or plate stem are areas of shell plates and centreline girder or of longitudinal bulkhead on the centreline on a breadth not exceeding ten times the thickness of relevant plates.

The plate thickness t_{net}^{stem} in mm, of combined and plate stems, as well as of the structure shown in Fig. 3.10.2.6.2-2, shall not be less than determined by the formula:

$$t_{net}^{stem} = 1,2 t_{net} \cdot (a_b/a) \cdot \sqrt{\sigma_y/\sigma_{y1}}, \quad (3.11.2.14.7-3)$$

where: t_{net} - net thickness of the shell plating in accordance with 3.11.2.4.2;

a - main framing spacing, in m;

a_b - spacing, in m, of transverse brackets of stem;

σ_y - yield stress, in N/mm^2 , of shell plating material;

σ_{y1} - yield stress, in N/mm^2 , of stem plate materia.

3.11.2.15 Appendages.

3.11.2.15.1 All appendages are to be designed to withstand forces appropriate for the location of their attachment to the hull structure or their position within a hull area.

3.11.2.15.2 Load definition and response criteria are to be determined by the Register.

3.11.2.16 Local details.

3.11.2.16.1 For the purpose of transferring ice-induced loads to supporting structure (bending moments and shear forces), local design details are to comply with the requirements of the Register.

3.11.2.16.2 The loads carried by a member in way of cut-outs are not to cause instability. Where necessary, the structure is to be stiffened.

3.11.2.17 Direct calculations.

3.11.2.17.1 Application.

Direct calculations are not to be utilised as an alternative to the analytical procedures prescribed for the shell plating and local frame requirements given in **3.11.2.4**, **3.11.2.6** and **3.11.2.7**.

Direct calculations should be performed by the finite element method in a static nonlinear elastic-plastic formulation. When performing calculations, the nonlinear relationship between stresses and deformation s shall be taken into account when the yield strength of the material is reached.

A linear tensile diagram should be used to describe material properties.

3.11.2.17.2 Requirements for a finite element model.

When performing calculations, a three-dimensional finite element model shall be used. The scantling of model shall be chosen to include a section of the side grillage located in the area of ice reinforcements in accordance with **3.11.2.2**, and also the minimum requirements for the dimensions of the finite element model are fulfilled, as are given in table 3.11.2.17.2-1.

Table 3.11.2.17.2-1 Minimum requirements for a finite element model

Boundary	Type of side structure	
	Double side structure	Single side structure
Fore	Transverse bulkhead	
Aft	Transverse bulkhead	
Upper	Upper deck	Deck or platform above the upper edge of the ice belt
Lower	Double bottom	Deck or platform below the upper edge of the ice belt

The finite element model shall repeat the hull design.

Ultimate conditions shall be selected in accordance with Table 3.11.2.17.2-2.

Table 3.11.2.17.2-2 Ultimate conditions

Location of finite element model boundary	Shear			Turn		
	δ_x	δ_y	δ_z	θ_x	θ_y	θ_z
Upper and lower boundaries	-	x	x	x	x	x
Fore and aft boundaries	x	x	-	x	x	x
<i>Note.</i> x – fixed shear						

The finite-element model shall include shell plating, web frames, stringers, deep members, double-side plating and adjacent framing, stiffeners of deep members webs, knees and brackets.

The degree of structural idealization when creating the finite element model shall be sufficient to solve the nonlinear problem, and the following minimum requirements shall also be met:

shell plating, double-side plating, web frames, stringers and face plates and beam flanges of deep members shall be modeled by plate elements;

deep members outside the area of ice strengthening shall be modeled by beam elements;

stiffeners of deep members webs shall be modeled by rod elements. Scantling of web shall be selected sufficient to solve a nonlinear problem, the following minimum requirements shall also be fulfilled:

preference shall be given to rectangular finite elements close in shape to a square; aspect ratio should be no more than 1/3;

the use of triangular elements shall be avoided wherever possible;

the web of the deep member shall be divided in height by at least five elements;

structural elements in which stress concentration zones or high strains can occur shall be modeled by a fine mesh; a large mesh can be used to model structural elements outside the ice strengthening region.

The thickness of the finite elements shall be assumed equal to the thickness of the net structure.

3.11.2.17.3 Strength criteria.

The purpose of performing a direct calculation is to demonstrate that, grillage ultimate pressure P_{ult} in MPa, not lower than the design ice pressure within the region considered in accordance with 3.11.2.3.4 and applied to the load patch according to **3.11.2.17.4**.

The carrying capacity of the grillage is determined according to **3.11.2.17.5**.

3.11.2.17.4 Ice load curve.

The parameters of the ice load are determined according to 3.11.2.3.3. Other loads shall not be taken into account.

The curve of the ice load shall be placed along the normal to the shell plating.

The curve of the ice load shall be placed in places of the lowest carrying capacity of a web frame or stringer. At a minimum, the following locations shall be considered:

the upper edge of the load curve is combined with the upper boundary of the ice belt, the curve is symmetrical with respect to the vertical axis connected to the web of the middle web frame of the grillage;

the lower edge of the load curve is combined with the lower boundary of the ice belt, the curve is symmetrical with respect to the vertical axis connected to the web of the middle web frame of the grillage;

the center of the load patch is combined with the mid-span of the middle web frame of the grillage;

the center of the load patch is combined with the mid-span of the middle supporting stringer of the grillage.

3.11.2.17.5 Grillage ultimate pressure.

Grillage ultimate pressure is determined on the basis of nonlinear static finite element calculation by gradually increasing the estimated load. The step of increasing the load shall be small enough to ensure the accuracy of the curve ($P - \delta$).

The technical capability to control the possible loss of stability of structural members shall be ensured by a method agreed with the Register.

The ultimate pressure P_{ult} is determined from the curve ($P - \delta$) by the method of intersecting tangents in accordance with Fig. 3.11.2.17.5.

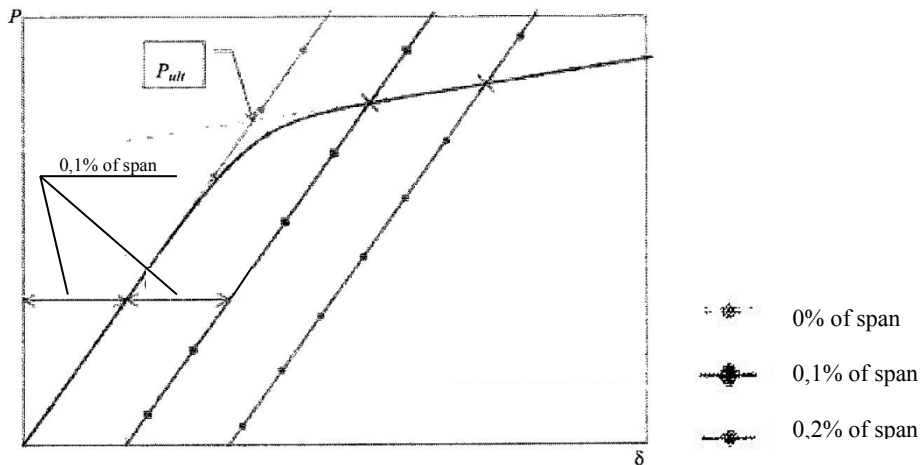

Note: P – pressure of grillage;

δ – maximum arrow deflection of the web frame or the supporting stringer.

Fig. 3.11.2.17.5 Determination of the grillage ultimate pressure by the intersection of tangents

3.11.2.17.6 Software Requirements.

The software for performing finite element calculations should allow modeling the structure, taking into account the nonlinearity of the material properties, creating a finite element mesh and performing elastic-plastic calculations in accordance with the requirements 3.11.2.17.1 ÷ 3.11.2.17.5.

In addition, the software used shall output reports on errors that occur during calculations.

3.11.2.18 Welding.

3.11.2.18.1 All welding within ice-strengthened areas is to be of the double continuous type.

3.11.2.18.2 Continuity of strength is to be ensured at all structural connections.

3.12 BALTIC ICE CLASS SHIPS

3.12.1 GENERAL

3.12.1.1 The requirements for the Baltic ice class ships comply with the requirements of the Finnish-Swedish rules for ice class ships, 2017, and apply to ships intended for operation in the Baltic Sea in winter, as well as in the waters of other seas with similar ice conditions.

3.12.1.2 Ships intended to operate under appropriate ice and climatic conditions are provided with the relevant signs by the Register after fulfilling relevant to the sign requirements of this section and 2.9 “Requirements for machinery installations of the Baltic ice classes” of Part VII “Machinery installations” and

2.11 "Additional requirements for ships of the Baltic ice classes "Part of the III "Equipment arrangements and outfit".

3.12.2 BALTIC ICE CLASSES

3.12.2.1 The symbols and descriptions of the Baltic ice classes are listed in Table 2.2.3.1-2, Part I «Classification».

3.12.3 BALTIC ICE CLASS DRAUGHT

3.12.3.1 Верхня і нижня льодові ватерлінії.

The upper ice waterline – a line enveloping the highest points of the waterline at which the ship will navigate in the ice. Such a line enveloping the indicated points may be a broken line.

The lower ice waterline - a line enveloping the lowest points of the waterline at which the ship will navigate in the ice. Such a line enveloping the indicated points may be a broken line.

3.12.3.2 Maximum and minimum draught fore and aft.

3.12.3.2.1 The maximum and minimum ice class draughts fore and aft shall be determined in accordance with UIWL and LIWL.

Restrictions on draft when operating in ice shall be entered in the ship's documents and stored on board in a place accessible to the master of the ship. The maximum and minimum ice class draughts fore and aft shall be stated in the Supplement to Classification certificate (form 3.1.2-1). Fresh Water Load Line in Summer is above *UIWL*, a warning sign of a triangular shape and a draft mark of an ice class ship on the maximum permissible draft of an ice class ship on the midship shall be applied on the ship's side, appropriate entry shall also be made in the classification certificate.

The draught and trim, limited by the LWL, must not be exceeded when the ship is navigating in ice. The salinity of the sea water along the intended route shall be taken into account when loading the ship.

The ship shall always be loaded down at least to the BWL when navigating in ice. Any ballast tank, situated above the BWL and needed to load down the ship to this water line, shall be equipped with devices to prevent the water from freezing. In determining the BWL, regard shall be paid to the need for ensuring a reasonable degree of ice-going capability in ballast. The propeller shall be fully submerged, if possible entirely below the ice. The forward draught shall be at least $(2 + 0,00025\Delta) h_0$, but need not exceed $4h_0$,

where: Δ – displacement of the ship, in t, on the maximum ice-class draught according to **3.12.3.1**;
 h_0 – level ice thickness, in m, according to **3.12.4.2.1**.

3.12.4 HULL STRUCTURAL DESIGN

3.12.4.1 General.

The method for determining the hull scantlings is based on certain assumptions concerning the nature of the ice load on the structure. These assumptions are from full scale observations made in the northern Baltic.

It has thus been observed that the local ice pressure on small areas can reach rather high values. This pressure may be well in excess of the normal uniaxial crushing strength of sea ice. The explanation is that the stress field in fact is multiaxial.

Further, it has been observed that the ice pressure on a frame can be higher than on the shell plating at midspacing between frames. The explanation for this is the different flexural stiffness of frames and shell plating. The load distribution is assumed to be as shown in figure 3.12.4.1-1.

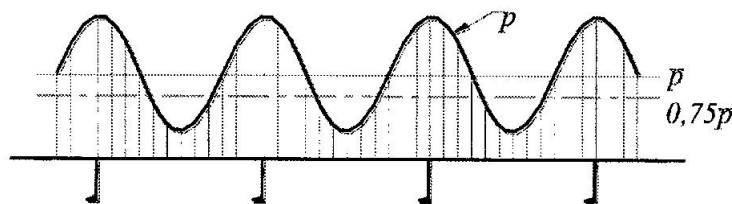

Fig. 3.12.4.1-1
Ice load distribution on a ship's side

For the formulae and values given in this section for the determination of the hull scantlings more sophisticated methods may be substituted subject to approval by the Register. If scantlings derived from these regulations are less than those required by the Register for an unstrengthened ship, the requirements of **3.12.4.3** - **3.12.4.5** shall be met.

When performing strength calculations by numerical methods, the characteristics of the load curve (p , h , l_a) shall be adopted in accordance with **3.12.4.2**.

The pressure shall be taken equal to $1,8p$, where p is determined in accordance with **3.12.4.2.2**. The curve shall be located in regions of construction with minimal carrying capacity under the combined action of buckling and shear. In particular, it is necessary to consider cases where the center of the curve is at a level of $UIWL$, at a distance $0,5h_0$ below $LIWL$, as well as for several intermediate positions vertically. Several horizontal positions of the curve shall be considered, in particular, in the middle of the span of the framing members or in the half the distance between the members. In addition, if for this design a direct determination of the length of the ice load distribution l_a is not possible, several values of l_a shall be considered using the appropriate values of coefficient c_a .

Permissible stresses for structures shall be taken according to the Mises theory, taking into account the combined effect of buckling and shear, not higher than the yield strength of the material σ_y .

When performing direct calculations using the theory of membr buckling, the permissible shear stress when using the theory of membr buckling shall be taken not more than $0,9\tau_y$, де $\tau_y = \sigma_y / \sqrt{3}$. If the scantling of structures obtained in accordance with these requirements are smaller than the scantling required for this ship in accordance with other requirements of the regulatory documents of the Register, without taking into account the requirements for ice strengthening, the latter shall be used.

Notes: **1.** The spacing between the deep mebers and the span length of the framing mebers are used in this section are generally measured (in accordance with the applicable requirements of the Register) along the plating; for shell plates - perpendicular to the axis of the deep mebers; for elements with a top plate - along the top plate; for flat profile members - along the free edge. For curved elements, the span (or distance between the memebrs) is determined as the length of the chord between the extreme points of the span (or the distance between the memebrs).

The end points of the span are determined by the intersection of the face plate or the upper edge of the element with the supporting structure (stringer, web frame, deck or bulkhead). The procedure for determining the span and the spacing between the framing memebrs for curved elements is given in Fig. 3.12.4.1-2.

2. When determining the section modulus of the framing members, plating face plate shall be taken into account, the width of which is determined in accordance with the requirements of **1.6**.

In any case, the width of the face plate shall not be greater than prescribed by the requirements of the Regulations of the Register for that type of ship.

3. Requirements for the section modulus and the cross-sectional area of the webs of deep and web framin members according to **3.12.4.4**, **3.12.4.5** and **3.12.4.6**, refer to the effective cross-section of the profile. If the memebr is installed perpendicular to the top plate, the necessary cross-sectional characteristics shall be increased in accordance with the requirements of **1.6.1.4**.

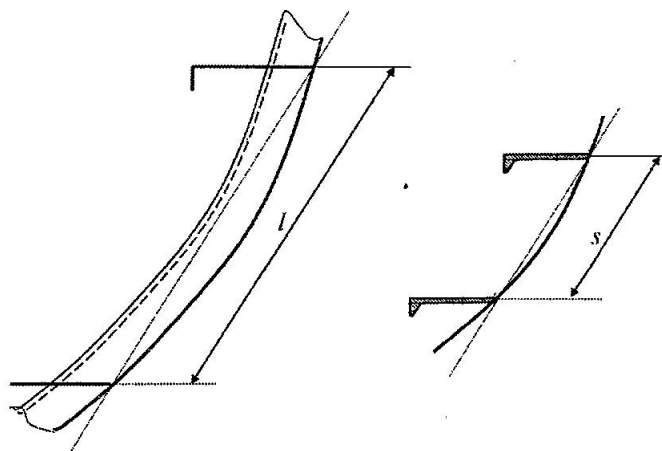

Fig. 3.12.4.1-2

Determination of the span of the frame (left) and the distance between the deep members (right) for curved elements.

3.12.4.1.1 Regions.

For the purpose of this section, the ship's hull is divided into regions as follows (see also figure 3.12.4.1-1):

Forward region: From the stem to a line parallel to and $0.04 \cdot L$ aft of the forward borderline of the part of the hull where the waterlines run parallel to the centreline. For ice classes **IA Super** and **IA** the overlap over the borderline need not exceed 6 meters, for Baltic ice classes **IB** and **IC** this overlap need not exceed 5 meters.

Midship region: From the aft boundary of the Forward region to a line parallel to and $0.04 \cdot L$ aft of the aft borderline of the part of the hull where the waterlines run parallel to the centreline. For ice classes **IA Super** and **IA** the overlap over the borderline need not exceed 6 meters, for Baltic ice classes **IB** and **IC** this overlap need not exceed 5 meters.

Aft region: From the aft boundary of the Midship region to the stern.

L- as defined in 1.1.3.

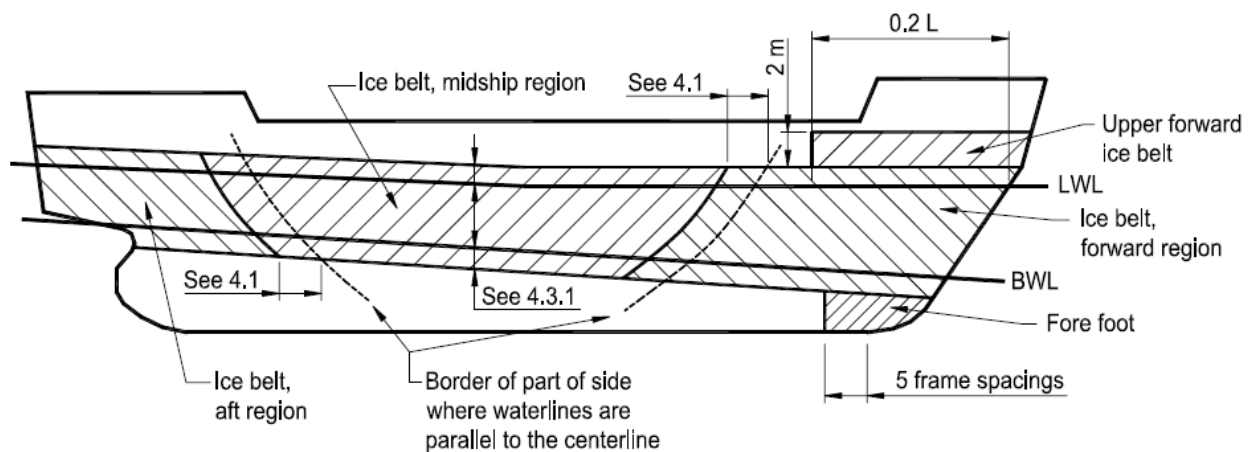

Fig. 3.12.4.1.1
Regions of ice strengthening

3.12.4.2 Ice load.

3.12.4.2.1 Height of load area.

An ice-strengthened ship is assumed to operate in open sea conditions corresponding to a level ice thickness not exceeding h_i . The design height (h) of the area actually under ice pressure at any particular point of time is, however, assumed to be only a fraction of the ice thickness. The values for h_i and h are given in the following table 3.12.4.2.1:

Table 3.12.4.2.1

Baltic Ice Class	h_i , in m	h , in m
IA Super	1,0	0,35
IA	0,8	0,3
IB	0,6	0,25
IC	0,4	0,22

3.12.4.2.2 Ice pressure.

The design ice pressure is determined by the formula:

$$p = c_d \cdot c_p \cdot c_a \cdot p_0, \quad (3.12.4.2.2)$$

where: c_d - a factor which takes account of the influence of the size and engine output of the ship. c_d shall not be taken greater than 1,0 and is calculated by the formula:

$$c_d = (ak + b)/1000,$$

$$\text{where: } k = \sqrt{\Delta P/1000};$$

a and b are given in the following table 3.12.4.2.2-1:

Таблица 3.12.4.2.2-1

	Region			
	Forward		Midship & Aft	
	$k \leq 12$	$k > 12$	$k \leq 12$	$k > 12$
a	30	6	8	2
b	230	518	214	286

Δ - the displacement of the ship at maximum ice class draught, in t (refer to **3.12.3.1**);

P - the actual continuous engine output of the ship, in kW.

If, in addition to the main engine (s), there are additional sources of traction power (for example, a shaft generator operating in electric motor mode), their capacity shall also be included in the total power used to determine the dimensions of the hull structures. The power of the main machinery, used to determine the dimensions of the hull structures, shall be given on the drawing of the shell plating extension;

c_p - a factor which takes account of the probability that the expected value of ice load in this area of the hull is changed compared with the load in the forward area.

c_p as defined in Table 3.12.4.2.2-2.

Table 3.12.4.2.2-2

Baltic ice class	Region		
	Forward	Midship	Aft
IA Super	1,0	1,0	0,75
IA	1,0	0,85	0,65
IB	1,0	0,7	0,45
IC	1,0	0,5	0,25

c_a - a factor which takes account of the probability that the full length of the area under consideration will be under pressure at the same time. c_a is calculated by the formula:

$$c_a = \sqrt{l_0/l_a}, \quad 0,35 \leq c_a \leq 1,0,$$

where: $l_0 = 0,6$ m;

l_a - as defined in Table 3.12.4.2.2-3;

p_0 = the nominal ice pressure; the value 5.6 MPa shall be used.

Table 3.12.4.2.2-3

Construction	Framing	l_a
Shell plating	Transverse	Frame spacing
	Longitudinal	1,7 · (frame spacing)
Framing members	Transverse	Frame spacing
	Longitudinal	Span of frame
Stringer		Span of stringer
Web frame		2 · (web frame spacing)

3.12.4.3 Shell plating.

3.12.4.3.1 Vertical extension of ice strengthening (ice belt). The vertical extension of the ice belt shall be as in Table 3.12.4.3.1 (див. рис. 3.12.4.1.1).

Table 3.12.4.3.1

Ice Class	Regions	Above UIWL	Below LIWL
IA Super	Forward	0,6 m	1,2 m
	Midship		
	Aft		1,0 m
IA	Forward	0,5 m	0,9 m
	Midship		0,75 m
	Aft		
IB and IC	Forward	0,6 m	0,7 m
	Midship		0,6 m
	Aft		

In addition, the following areas shall be strengthened.

Fore foot. For Baltic ice class **IA Super**, the shell plating below the ice belt from the stem to a position five main frame spaces abaft the point where the bow profile departs from the keel line shall have at least the thickness required in the ice belt in the midship region.

Upper forward ice belt. For Baltic ice classes **IA Super** and **IA** on ships with an open water service speed equal to or exceeding 18 knots, the shell plate from the upper limit of the ice belt to 2 m above it and from the stem to a position at least 0.2 L abaft the forward perpendicular, shall have at least the thickness required in the ice belt in the midship region. A similar strengthening of the bow region is advisable also for a ship with a lower service speed, when it is, e.g. on the basis of the model tests, evident that the ship will have a high bow wave.

Sidescuttles shall not be situated in the ice belt. If the weather deck in any part of the ship is situated below the upper limit of the ice belt (e.g. in way of the well of a raised quarter decker), the bulwark shall be given at least the same strength as is required for the shell in the ice belt.

The strength of the construction of the freeing ports shall meet the same requirements.

3.12.4.3.2 Plate thickness in the ice belt.

For transverse framing the thickness of the shell plating shall be determined by the formula:

$$t = 667 \cdot s \cdot \sqrt{(f_1 \cdot p_{pl} / \sigma_y)} + t_c. \quad (3.12.4.3.2-1)$$

For longitudinal framing the thickness of the shell plating shall be determined by the formula:

$$t = 667 \cdot s \cdot \sqrt{p / (f_2 \cdot \sigma_y)} + t_c. \quad (3.12.4.3.2-2)$$

where: s – the frame spacing, in m;

$$p_{pl} = 0,75p, \text{ in MPa};$$

p – as given in **3.12.4.2.2**;

$$f_1 = 1,3 - 4,2 / (h/s + 1,8)^2, \text{ maximum } 1,0;$$

$$f_2 = 0,6 + 0,4 / (h/s) \text{ with } h/s \leq 1;$$

$$f_2 = 1,4 - 0,4 \cdot (h/s) \text{ with } 1 < h/s \leq 1,8,$$

where: h – as given in **3.12.4.2.1**;

σ_y – yield stress of the material, in MPa, the following values shall be used:

$\sigma_y = 235$ MPa for normal-strength hull structural steel;

$\sigma_y = 315$ MPa or higher for high-strength hull structural steel;

t_c – increment for abrasion and corrosion, in mm, normally t_c shall be 2 mm.

if a special surface coating, by experience shown capable to withstand the abrasion of ice, is applied and maintained may be reduced to 1 mm by agreement with the shipowner and subject to the providing the Register with documents listed in 8.6 Guidance on the application of the Finnish-Swedish regulations for ice class ships.

At the same time, the dimensions determined by the increment for corrosion and abrasion shall also be indicated on the drawing of the hull structures. A special mark is entered in the Classification Certificate of such ships (refer to 2.3.1, Part I "Classification").

3.12.4.4 Frames.

3.12.4.4.1 Vertical extension of ice strengthening.

The vertical extension of the ice strengthening of the framing shall be at least as given in Table 3.12.4.4.1.

Table 3.12.4.4.1

Baltic ice class	Region	Above UIWL	Below LIWL
IA Super	Forward	1,2 m	To double bottom or below top of floors
	Midship		2,0 m
	Aft		1,6 m
IA, IB and IC	Forward	1,0 m	1,6 m
	Midship		1,3 m
	Aft		1,0 m

Where an upper forward ice belt is required (see Fig. 3.12.4.3.1) the ice-strengthened part of the framing shall be extended at least to the top of this ice belt.

Where the ice-strengthening would go beyond a deck or a tanktop by no more than 250 mm, it can be terminated at that deck or tanktop.

3.12.4.4.2 Transverse frames.

3.12.4.4.2.1 Section modulus.

The section modulus of a main or intermediate transverse frame shall be calculated by the formula:

$$Z = p \cdot s \cdot h \cdot l \cdot 10^6 / (m_t \cdot \sigma_y). \quad (3.12.4.4.2.1-1)$$

Cross section area of a main or intermediate transverse frame shall shall not be less than determined by Formula:

$$A = \sqrt{3} \cdot f_3 \cdot p \cdot h \cdot s \cdot 10^4 / (2 \cdot \sigma_y). \quad (3.12.4.4.2.1-2)$$

where: p - ice pressure as given in 3.12.4.2.2, in MPa;

s - frame spacing, in m;

h - height of load area as given in 3.12.4.2.1, in m;

l - span of the frame, in m;

$$m_t = 7m_0 / [7 - (5h/l)];$$

$f_3 = 1,2$ - factor taking into account the influence on the maximum cutting force of the load curve position and distribution of shear stresses;

σ_y - yield stress as in 3.12.4.3.2, in MPa;

m_0 - values are given in Table 3.12.4.4.2.1.

The boundary conditions are those for the main and intermediate frames. Load is applied at mid span.

Where less than 15% of the span, l , of the frame is situated within the ice-strengthening zone for frames as defined in 3.12.4.4.2.1 ordinary frame scantlings may be used.

Table 3.12.4.4.2.1

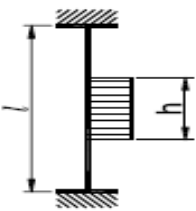
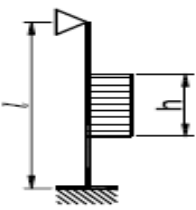
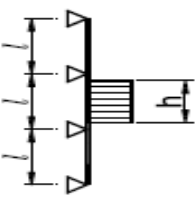
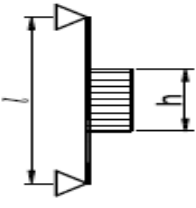
Boundary Condition	m_o	Example
	7	Frames in a bulk carrier with top wing tanks
	6	Frames extending from the tank top to a single deck
	5.7	Continuous frames between several decks or stringers
	5	Frames extending between two decks only

3.12.4.4.2.2 Upper end of transverse framing.

The upper end of the strengthened part of a main frame and of an intermediate ice frame shall be attached to a deck of an ice stringer in accordance with 3.12.4.5. Where a frame terminates above a deck or a stringer which is situated at or above the upper limit of the ice belt, the part above the deck or stringer may have the scantlings required by the classification society for an unstrengthened ship and the upper end of an intermediate frame may be connected to the adjacent frames by a horizontal member having the same scantlings as the main frame.

3.12.4.4.2.3 Lower end of transverse framing.

The lower end of the strengthened part of a main frame and of an intermediate ice frame shall be attached to a deck, tanktop or ice stringer in accordance with 3.12.4.5.

Where an intermediate frame terminates below a deck, tanktop or ice stringer which is situated at or below the lower limit of the ice belt, the lower end may be connected to the adjacent main frames by a horizontal member of the same scantlings as the frames.

The main frame below the lower limit of the ice belt shall be connected, as well as in the middle of ice belt in accordance 3.12.4.4.1.

3.12.4.4.3 Longitudinal frames.

The requirements of this section apply to the longitudinal frames, regardless of the method of fixing them at the ends.

3.12.4.4.3.1 Longitudinal frames, fixed with or without brackets.

The section modulus of a longitudinal frame shall be calculated by the formula:

$$Z = f_4 \cdot p \cdot h \cdot l^2 \cdot 10^6 / (m \cdot \sigma_y). \quad (3.12.4.4.3.1-1)$$

The shear area of a longitudinal frame shall be:

$$A = \sqrt{3} \cdot f_4 \cdot f_5 \cdot p \cdot h \cdot l \cdot 10^4 / (2 \cdot \sigma_y). \quad (3.12.4.4.3.1-2)$$

where: $f_4 = 1 - 0,2h/s$ – factor which takes account of the concentration of load to the point of support;

$f_5 = 2,16$ - factor taking into account the influence on the maximum cutting force of the load curve position and distribution of shear stresses;

p - ice pressure as given in 3.12.4.2.2, in MPa;

s - frame spacing, in m;

h - height of load area as given in 3.12.4.2.1, in m;

l - span of the frame, in m;

m - boundary condition factor; $m = 13.3$ for a continuous beam; where the boundary conditions deviate significantly from those of a continuous beam, e.g. in an end field, a smaller boundary factor may be required subject to providing the Register with appropriate documentation;

σ_y - yield stress as in 3.12.4.3.2, in MPa.

The actual cross-sectional area of the longitudinal is determined without taking into account the sectional area of the bracket.

3.12.4.4.4. General on framing.

3.12.4.4.4.1 Connection with supporting structures.

Within the ice-strengthened area all frames shall be effectively attached to all the supporting structures. A longitudinal frame shall be attached to all the supporting web frames and bulkheads by brackets. When a transversal frame terminates at a stringer or deck, a bracket or similar construction is to be fitted. When a frame is running through the supporting structure, both sides of the web plate of the frame are to be connected to the structure (by direct welding, collar plate or lug). When a bracket is installed, it has to have at least the same thickness as the web plate of the frame and the edge has to be appropriately stiffened against buckling.

3.12.4.4.4.2 Supporting of frames against tripping.

The frames shall be attached to the shell by double continuous weld. No scalloping is allowed (except when crossing shell plate butts).

The web thickness of the frames shall not be less than the greater of the following values:

$$h_w \cdot \sqrt{\sigma_y} / C,$$

where: h_w – web depth, in mm;

C – for a flat bulb;

C – elsewhere;

σ_y - yield stress as in 3.12.4.3.2, in MPa;

$$(t - t_c) / 2,$$

where: t – the thickness of the shell plating, required according to 3.12.4.3.2, in mm, in the determination of which σ_y is taken equal to the yield strength of the framing material;

for t_c – refer to 3.12.4.3.2;

or 9 mm.

If, instead of one of frames, a plate is adjacent to the shell plating (for example, deck, platform or double bottom top, plating of the transverse bulkhead), then its thickness shall comply with the above requirements at a width equal to the depth of the adjacent side frames. The following values of the variables are accepted: material properties of the plate, h_w - web height of adjacent frames, $C = 805$.

To avoid tripping, framing webs of asymmetrical profile and framing, not at right angles to the plating, shall be supported by brackets, intercostal stiffeners, stringers або іншими конструктивними елементами, spaced not more than 1.3 m. If the frame spacing is greater than 4 m, framing webs shall be supported in all regions of ice strengthenings of all Baltic ice classes.

If the frame spacing is 4 m or less, framing webs shall be supported in all regions of ice strengthenings of Baltic ice class **IA Super** ships, in forward and intermediate regions of ice strengthening of Baltic ice class

IA ships, in forward regions of ice strengthening of Baltic ice classes **IB** and **IC** ships. Alternative strengthening schemes can be grounded by direct calculation methods.

3.12.4.5 Ice stringers.

3.12.4.5.1 Stringers within the ice belt.

The section modulus of a stringer situated within the ice belt (see 3.12.4.3.1) shall be calculated by the formula:

$$Z = f_6 \cdot f_7 \cdot p \cdot h \cdot l^2 \cdot 10^6 / (m \cdot \sigma_y). \quad (3.12.4.5.1-1)$$

The shear area shall be:

$$A = \sqrt{3} \cdot f_6 \cdot f_7 \cdot f_8 \cdot p \cdot h \cdot l \cdot 10^4 / (2\sigma_y). \quad (3.12.4.5.1-2)$$

where: p - ice pressure as given in 3.12.4.2.2, in MPa;

h - height of load area as given in 3.12.4.2.1, in m.

The product $p \cdot h$ shall not be taken as less than 0,15;

l - span of the stringer, in m;

m - boundary condition factor as defined in 3.12.4.4.3;

$f_6 = 0,9$ - factor which takes account of the distribution of load to the transverse frames;

$f_7 = 1,8$ - safety factor for stringer;

$f_8 = 1,2$ - factor taking into account the influence on the maximum cutting force of the load curve position and the distribution of shear stresses;

σ_y - yield stress as in 3.12.4.3.2, in MPa.

3.12.4.5.2 Stringers outside the ice belt.

The section modulus of a stringer situated outside the ice belt but supporting ice-strengthened frames shall be calculated by the formula:

$$Z = f_9 \cdot f_{10} \cdot p \cdot h \cdot l^2 \cdot (1 - h_s/l_s) \cdot 10^6 / (m \cdot \sigma_y). \quad (3.12.4.5.2-1)$$

The shear area shall be:

$$A = \sqrt{3} \cdot f_9 \cdot f_{10} \cdot f_{11} \cdot p \cdot h \cdot l \cdot (1 - h_s/l_s) \cdot 10^4 / (2\sigma_y). \quad (3.12.4.5.1-2)$$

where: p - ice pressure as given in 3.12.4.2.2, in MPa;

h - height of load area as given in 3.12.4.2.1, in m.

The product $p \cdot h$ shall not be taken as less than 0,15;

l - span of the stringer, in m;

m - boundary condition factor as defined in 3.12.4.4.3;

l_s - the distance to the adjacent ice stringer, in m;

h_s - the distance to the ice belt, in m;

$f_9 = 0,8$ - factor which takes account of the distribution of load to the transverse frames;

$f_{10} = 1,8$ - safety factor for stringer;

$f_{11} = 1,2$ - factor taking into account the influence on the maximum cutting force of the load curve position and the distribution of shear stresses;

σ_y – yield stress as in 3.12.4.3.2, in MPa.

3.12.4.5.3 Deck strips.

Narrow deck strips abreast of hatches and serving as ice stringers shall comply with the section modulus and shear area requirements in 3.12.4.5.1 and 3.12.4.5.2 respectively. In the case of very long hatches the classification society may permit the product $p \cdot h$ to be taken as less than 0.15, but in no case as less than 0.10.

Regard shall be paid to the deflection of the ship's sides due to ice pressure in way of very long hatch openings when designing weatherdeck hatch covers with length $B/2$ and their fittings.

3.12.4.6 Web frames.

3.12.4.6.1 Ice Load.

The load transferred to a web frame from an ice stringer or from longitudinal framing shall be calculated by the formula:

$$F = f_{12} p h S, \quad (3.12.4.6.1)$$

where: p - ice pressure as given in 3.12.4.2.2, in MPa, in calculating c_a however, l_a shall be taken as $2S$;

h - height of load area as given in 3.12.4.2.1, in m.

The product $p \cdot h$ shall not be taken as less than 0.15;

S - distance between web frames, in m;

$f_{12} = 1,8$ – safety factor for web frame.

shall be taken as defined in 3.12.4.5.2.

3.12.4.6.2 Section modulus and shear area.

Section modulus and shear area shall not be taken less than determined by Formulae:

Shear area

$$A = \sqrt{3} \cdot \alpha \cdot f_{13} \cdot Q \cdot 10^4 / 2\sigma_y, \quad (3.12.4.6.2-1)$$

Section modulus

$$Z = M \cdot \sqrt{1/[1 - (\gamma A/A_a)^2]} \cdot 10^6 / \sigma_y, \quad (3.12.4.6.2-2)$$

where: M - maximum calculated shear force under the load F , as given in, or $M = 0,193Fl$;

for F – refer to 3.12.4.6.1;

l – web frame span, in m;

γ - as given in the table 3.12.4.6.2;

A - required shear area;

A_a - actual cross sectional area of the web frame, $A_a = A_f + A_w$;

A_f – cross section area of free flange;

A_w – cross section area of web plate.

Table 3.12.4.6.2

A_f/A_w	0	0,2	0,4	0,6	0,8	1,0	1,2	1,4	1,6	1,8	2,0
α	1,5	1,23	1,16	1,11	1,09	1,07	1,06	1,05	1,05	1,04	1,04
γ	0	0,44	0,62	0,71	0,76	0,80	0,83	0,85	0,87	0,88	0,89

3.12.4.7 Stem.

The stem shall be made of rolled, cast or forged steel or of shaped steel plates. A sharp edged stem (see figure 3.12.4.7.1) is allowed.

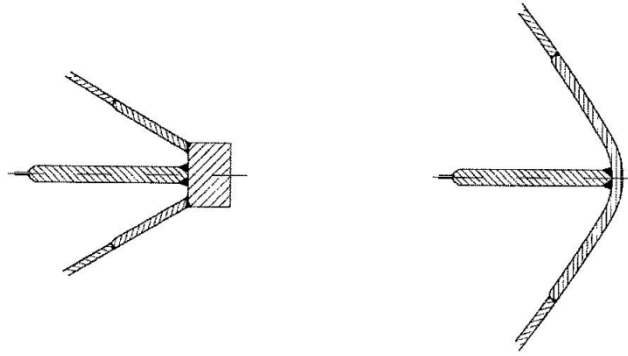

Fig. 3.12.4.7 Examples of a suitable stem

The plate thickness of a shaped plate stem and in the case of a blunt bow, any part of the shell which forms an angle $\alpha \geq 30^\circ$ and $\psi \geq 75^\circ$ (refer to Fig 3.12.4.7.2), to the centreline in a horizontal plane, shall be calculated according to the formula in **3.12.4.3.2**, assuming that:

s - spacing of elements supporting the plate, in m;

$p_{PL} = p$, in MPa (refer to **3.12.4.3.2**);

l_a - spacing of vertical supporting elements, in m.

The stem and the part of a blunt bow defined above shall be supported by floors or brackets spaced not more than 0.6 m apart and having a thickness of at least half the plate thickness.

The reinforcement of the stem shall extend from the keel to a point 0.75 m above UIWL or, in case an upper forward ice belt is required (refer to **3.12.4.3.1**), to the upper limit of this.

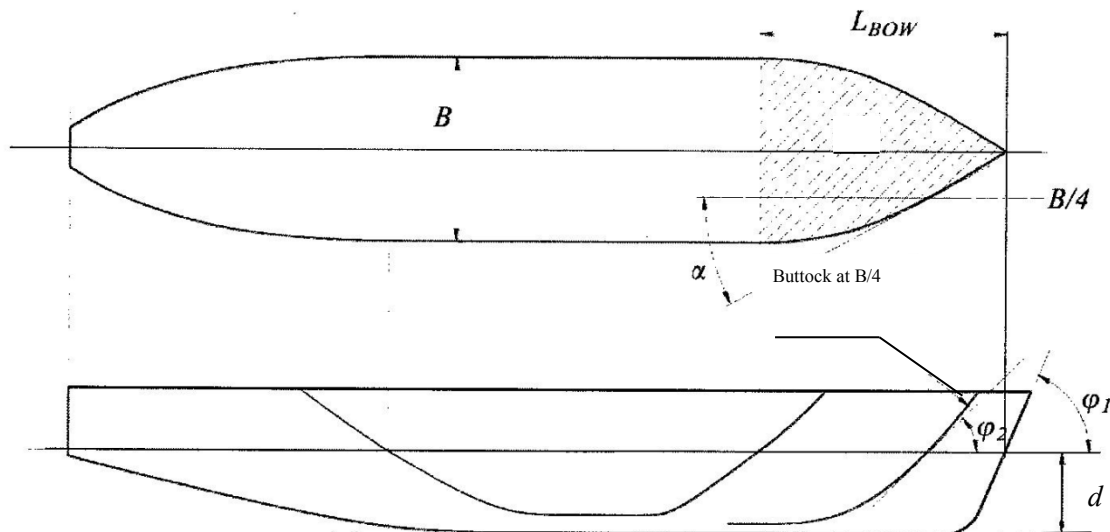

Fig. 3.12.4.7.2

L_{BOW} – length of the bow; B - maximum breadth of the ship; d - draft; α - the angle of the waterline at $B/4$, in deg.; φ_1 – the rake of the stem at the centreline, in deg. With bulb $\varphi_1 = 90^\circ$; φ_2 – the rake of the bow at $B/4$, in deg.; $\psi = \arctan(\tan\varphi/\sin\alpha)$, in deg., using α and φ , corresponding to the location.

3.12.4.8 Stern.

The introduction of new propulsion arrangements with azimuthing thrusters or "podded" propellers, which provide an improved manoeuvrability, will result in increased ice loading of the aft region and the stern area. This fact should be considered in the design of the aft/stern structure.

An extremely narrow clearance between the propeller blade tip and the stern frame shall be avoided as a small clearance would cause very high loads on the blade tip (refer to 3.12.4.2.1).

On twin and triple screw ships the ice strengthening of the shell and framing shall be extended to the double bottom for 1.5 metres forward and aft of the side propellers.

Shafting and stern tubes of side propellers shall normally be enclosed within plated bossings.

If detached struts are used, their design, strength and attachments to the hull shall comply with requirements of 2.10.

3.13 ICE STRENGTHENING OF TUGS

3.13.1 General requirements.

3.13.1.1 Tugs provided with ice strengthening in compliance with the requirements stated below are provided with one of the following ice class marks in their class notation: **Ice2**, **Ice3**, **Ice4**, **Ice5**.

3.13.1.2 The hull form of ice-strengthened tugs shall be in accordance with the requirements of 3.10.1.2 for the hull form of the appropriate ice class ships.

3.13.1.3 Regions of ice strengthening.

3.13.1.3.1 For tugs, the boundaries of regions of ice strengthening shall be established in accordance with 3.10.1.3 as in the case of ice class ships, unless specifically provided otherwise below.

3.13.1.3.2 In tugs with a small length of loadline fore run ($b + L_3 < 0,35L$ – refer to 3.10.1.3) the intermediate region of ice strengthening (or the forward region where no intermediate region is established) shall be extended aft so that the forward boundary of the midship region would be at least $0,35L$ away from the forward perpendicular.

3.13.1.3.3 The parameters h_1 , h_3 , L_2 (refer to Fig. 3.10.1.3.2) shall be adopted from Table 3.13.1.3.3.

Table 3.13.1.3.3

Parameter, in m	Ice class	
	Ice2, Ice3	Ice4, Ice5
h_1	0,3	0,5
h_3	0,6	0,8
L_2	0,1L	0,15L

3.13.1.3.4 In tugs of ice classes **Ice2** and **Ice3**, an intermediate region of ice strengthening may also be established, and its boundaries shall be determined on the basis of the same regulations as for tugs of higher ice classes.

3.13.1.3.5 The regions of ice strengthening of tugs to which the requirements of this Chapter apply shall be determined based on Table 3.10.1.3.4 as in the case of a transport ship of the appropriate ice class, with due regard for **3.11.1.3.4**.

3.13.2 Structure.

3.13.2.1 The ice-strengthening structure of tugs shall comply with the requirements of 3.10.2 for construction of the appropriate ice class ships.

3.13.2.2 The hull attachments of ice-protection components of the azimuth thruster shall ensure their reliable connection to main and web framing and, as far as practicable, to the sternframe and to longitudinal and transverse bulkheads so as to rule out the possibility of crack formation as a result of ice impacts on the stern.

3.13.3 Ice load.

3.13.3.1 The ice pressure shall be determined by the following formulae:

.1 in region **AI**

$$p_{AI} = k_p p^0_{AI}, \quad (3.13.3.1.1)$$

where: p^0_{AI} - ice pressure in region **AI**, as determined in accordance with **3.10.3.2.1** as in the case of a transport ship whose ice class coincides with the ice class of the tug;

$$k_p = 1 \text{ with } N_\Sigma \leq N_0;$$

$$k_p = (N_\Sigma / N_0)^{0.4} \text{ with } N_\Sigma > N_0;$$

N_Σ - total shaft power of tug, in kW;

$$N_0 = C_N \Delta^{2/3};$$

C_N - factor to be taken from Table 3.13.3.1.1;

Δ - displacement to summer load waterline, in t;

Table 3.13.3.1.1

Factor	Ice category of tug			
	Ice2	Ice3	Ice4	Ice5
C_N	14	16	18	20

.2 in regions **A₁I**, **BI** and **CI**

$$p_{kI} = a_k p_{AI}, \quad (3.13.3.1.2)$$

for p_{AI} , refer to 3.11.3.1.1;

a_k – factor to be taken from Table 3.11.3.1.2 based on the region of ice strengthening and the ice class of the tug;

$k = \mathbf{A_1, B, C}$;

Table 3.13.3.1.2 Values of factor a_k

Regions	Ice class of tug			
	Ice2	Ice3	Ice4	Ice5
A ₁ I	0,55	0,6	0,65	0,65
BI	0,4	0,5	0,55	0,6
CI	0,65	0,7	0,75	0,75

.3 in regions II, III and IV, an ice pressure shall be taken as required by 3.10.3.2.5 as in the case of transport ships of appropriate ice class.

3.13.3.2 For tugs the vertical extension of ice load shall be adopted equal in all regions and shall be determined in accordance with 3.10.3.3.1 as in the case of the forward region of a transport ship whose ice class coincides with that of the tug. When determining u_m , the values of u shall be found for those sections only which are included in the forward region of ice strengthening of the tug.

3.13.3.3 For tugs the horizontal extension of ice load shall be adopted equal in all regions and shall be determined in accordance with 3.10.3.4.1 as in the case of the forward region of a transport ship whose ice class coincides with that of the tug. When determining β_m only those sections shall be considered which are included in the forward region of ice strengthening of the tug.

3.13.4 Scantlings of ice-strengthening structures.

3.13.4.1 The scantlings of ice-strengthening structures in tugs shall be determined in accordance with 3.10.4 as in the case of transport ships of the appropriate ice class, unless expressly provided otherwise below.

3.13.4.2 When establishing the shell plating thickness in regions of ice strengthening in accordance with 3.10.4.1, the wear allowance, Δs_{sp0} may be reduced if special measures are taken to protect the shell plating from corrosion wear and abrasion, but in any case, Δs_{sp0} shall be adopted not less than 2 mm.

3.13.4.3 In addition to the requirements of 3.10.4.10, the stem and sternframe shall have a sectional area not less than determined by the formula:

$$S = kS_0, \quad (3.13.4.3)$$

where: k – factor whose values shall be found in Table 3.11.4.3;

S_0 – area of stem or sternframe of the tug without ice class to be determined in accordance with 3.9.4.5 or 3.9.4.6.

Table 3.13.4.3 Values of factor k

Structural member	Ice class			
	Ice2	Ice3	Ice4	Ice5
Stem	1,2	1,3	1,4	1,5
Sternframe	1,1	1,2	1,3	1,4

3.14 REQUIREMENTS TO CONSTRUCTION OF ICE STRENGTHENING OF SHIPS INTENDED FOR OPERATION ASTERN

3.14.1 APPLICATION

3.14.1.1 Ships that shall comply with the requirements of this Chapter, at the request of the ship-owner, an additional **DAS** sign (“ice class mark”) is provided for the ship’s class notation (refer to **2.2.3.3.5**, Part I “Classification”).

3.14.2 REQUIREMENTS TO HULL CONSTRUCTION

3.14.2.1 The requirements of this paragraph apply to ships that are operated in the ice stern ahead, and are additional to the requirements of **3.10**, Part II “Hull”.

3.14.2.2 Regions.

3.14.2.2.1 For the purpose of this section, the ship’s hull is divided into regions as follows:

for ships that can run in ice, both ahead and astern:

forward – **A**;
intermediate – **A₁**;
midship – **B**;
aft – **C**;

for ships that can run in ice only astern:

forward – **A**;
midship – **B**;
aft – **C**.

3.14.2.2.2 By depth and by the bottom, the regions of ice reinforcement are divided into:

region of variable drafts and equivalent regions – **I**;
region, from the lower edge of region **I** to the upper edge of bilge strake **II**;
bilge strake **III**;
from the lower edge of bilge strake, where the plating has a slope to the horizon of 7° , to centre plane –

VI.

For ships that can run in ice only astern positions of forward, midship and aft ice regions are given relative to the plane of the flat side:

forward – from stem to L_3 line astern from forward boundary of flat side;
midship – from forward boundary of forward region to L_3 line ahead from aft boundary of flat side;
aft - from aft boundary of midship to sternframe.

The length of the ice belt in the forward region of the bottom is regulated by the parameter L_2 , equal to the distance from point **A** to the point of intersection of the main plane with the vertical line that defines the boundary of the forward region at the lower boundary of the ice belt.

These requirements must be met at both the upper and lower operational waterlines.

The position of the point **K** is defined as a point located at a distance of at least five normal spacings (refer to **1.1.3**, Part II “Hull”) ahead from the beginning of the skeg.

3.14.2.2.3 The extent of the ice reinforcement regions of ice class ships is determined according to Fig. 3.14.2.2.3 of this paragraph and Table 3.10.1.3.2, Part II “Hull”.

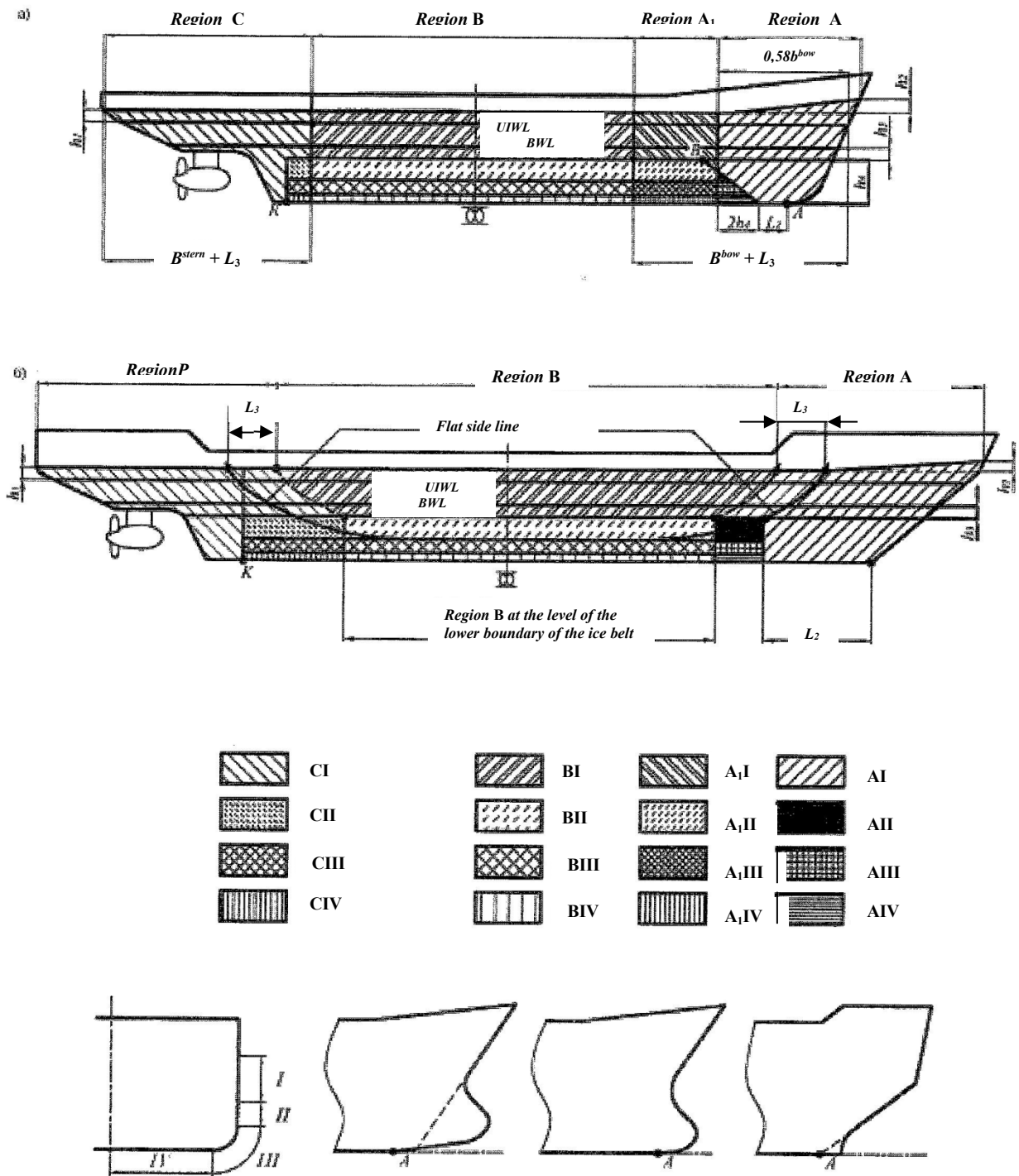

Fig. 3.14.2.2.3 Ice regions of ice class ships суден льодових класів:

a) ships designed to run in the ice, both ahead and astern;

б) ships designed to run in the ice only astern;

b^{bow} – the distance from the point of intersection of the UIWL with the stem to the cross section in which the UIWL has the largest breadth but no more $0,4L$;

b^{stern} the distance from the point of intersection of the UIWL with the sternframe to the cross section in which the UIWL has the largest breadth but no more $0,2L$.

3.14.2.2.4 The extent of the ice reinforcement regions of double-acting Arctic ships that can periodically perform icebreaking operations and have the ice class **Icebreaker 1** or **Icebreaker 2** in the class notation when running astern is determined according to Fig. 3.14.2.2.4 and Table 3.14.2.2.4.

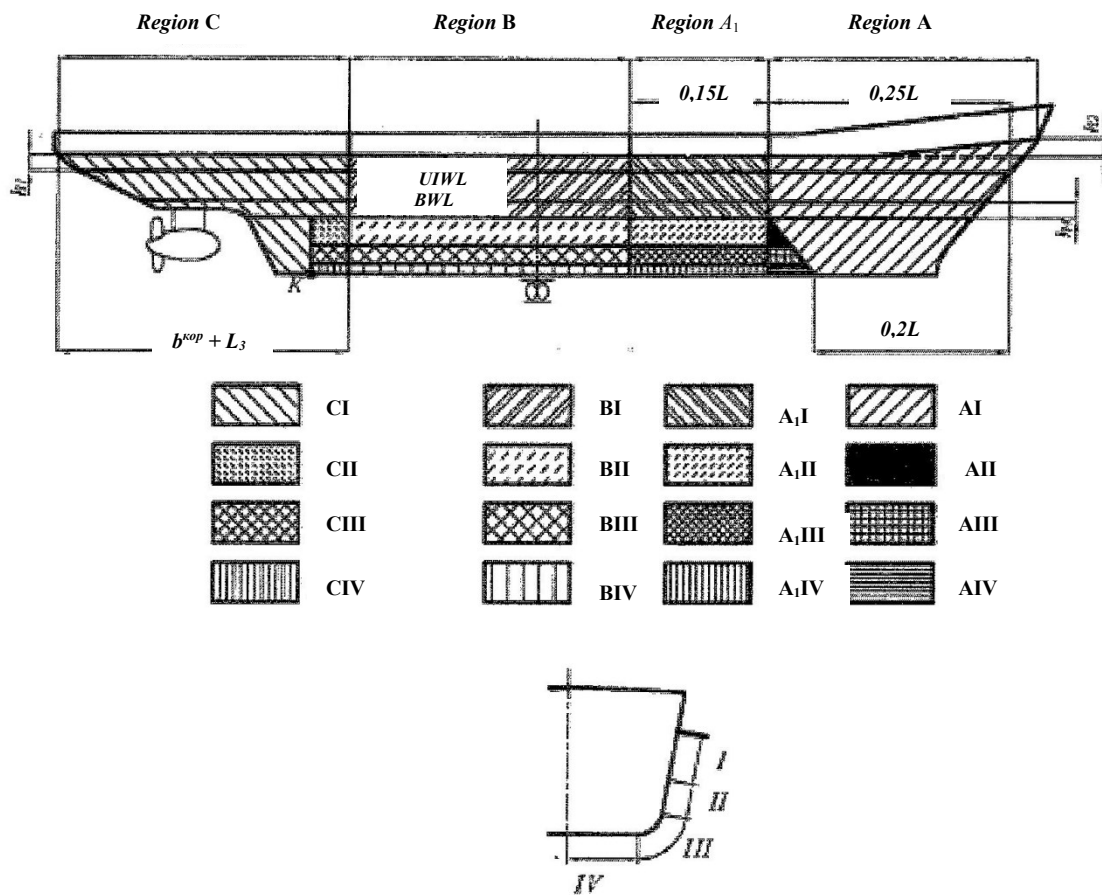

Fig. 3.14.2.2.4 Ice reinforcement regions of double-acting Arctic ships that have the ice class **Icebreaker 1** or **Icebreaker 2** in the class notation when running astern:

b^{kop} – the distance from the point of intersection of the UIWL with the sternframe to the cross section in which the UIWL has the largest breadth but no more $0,2L$.

Table 3.14.2.2.4

Parameter		Ice class	
		Icebreaker 2	Icebreaker 1
h_1 , m	if $B \leq 20$ m	0,75	
	if $B > 20$ m	$(0,5B + 8)/24$	
h_2 , m		1,4	1,1
h_3 , m		$1,6 + 1,6 h_1 \geq 2,8$	$0,4 + 1,6 h_1 \geq 1,6$
L_3 , m		0,06L	0,05L

3.14.2.2.5 Depending on the ice class, the requirements of the paragraph apply to the regions of ice reinforcement indicated in Table 3.14.2.2.5-1 (for ships that can run in the ice, both ahead and astern) and Table 3.14.2.2.5-2 (for ships that can run in the ice only astern) with a “+” sign. The absence in the column of the Table. 3.14.2.2.5-1 and Tab. 3.14.2.2.5-2 of the “+” sign means that the requirements of this paragraph do not apply to this reinforcement region.

Table 3.14.2.2.5-1

Ice class	Region depthwise															
	I				II				III				IV			
	Region lengthwise															
	A	A ₁	B	C	A	A ₁	B	C	A	A ₁	B	C	A	A ₁	B	C
Icebreaker 2	+	+	+	+	+	+	+	+	+	+	+	+	+	+	+	+
Icebreaker 1, Ice6	+	+	+	+	+	+	+	+	+	+	+	+	+	+	+	+
Ice5	+	+	+	+	+	+	+	+	+	+	+	+	+	+	+	+
Ice4	+	+	+	+	+	+	+	+	+	+		+	+	+	+	+
Ice3	+		+	+	+			+								
Ice2	+		+	+												
Ice1	+			+												

Table 3.14.2.2.5-2

Ice class	Region depthwise											
	I			II			III			IV		
	Region lengthwise											
	A	B	C	A	B	C	A	B	C	A	B	C
Ice6	+	+	+	+	+	+	+	+	+	+		+
Ice5	+	+	+	+	+	+		+	+			+
Ice4	+	+	+		+	+			+			+
Ice3	+	+	+			+						
Ice2	+	+	+									
Ice1			+									

3.14.2.3 Construction

3.14.2.3.1 Sternframe construction.

3.14.2.3.1.1 To increase the rigidity of the structures of the stern, to reduce the length of the aft overhang and protect the rudder propellers from the influence of ice, which falls into the area of the aft rake, the skeg shall be fitted in the centre plane.

The bottom surface of the skeg shall coincide with the flat bottom. The extent of the skeg lengthwise shall be consistent with the location of the transverse bulkheads of the ships stern.

The choice of skegs framing construction is carried out on the condition of coordination with the structural scheme of the aft rake bottom.

In the case of the longitudinal framing system of the aft rake bottom, vertical diaphragms are installed inside the skegs, located in the plane of the transverse framing of aft rake bottom, as well as in the plane of the transverse bulkheads.

The design of the diaphragms, bulkheads and platforms shall comply with the requirements of 3.10.2.4, Part II "Hull".

3.14.2.3.1.2 Rudder propeller support drum must have a reinforced thickened flange for bolting to the flange of the propeller-steering gear. The design of the drum and reinforcements should provide access to the bolt connection of the steering gear. Reinforcement of the supporting drum shall be joined with reinforced floors and double-bottom stringers. Additionally installed bottom strings shall be aligned with transverse bulkhead stiffeners, which enclose the steering gear compartment and smoothly form longitudinal members at a length of 3 to 4 spacings outside the compartment. Reinforce floors shall be supported by frames and longitudinal bulkheads stiffeners, reinforced in height to the nearest deck or platform.

3.14.2.4 Ice load.

3.14.2.4.1 The angles of the waterline in the aft end part are determined according to Fig. 3.14.2.4.1:

when installing one rudder propeller - as for stem according to 3.10.1.2.1, Part II "Hull";

when installing two/three rudder propellers – as for the parts of water lines located to the side of the axial line of the column.

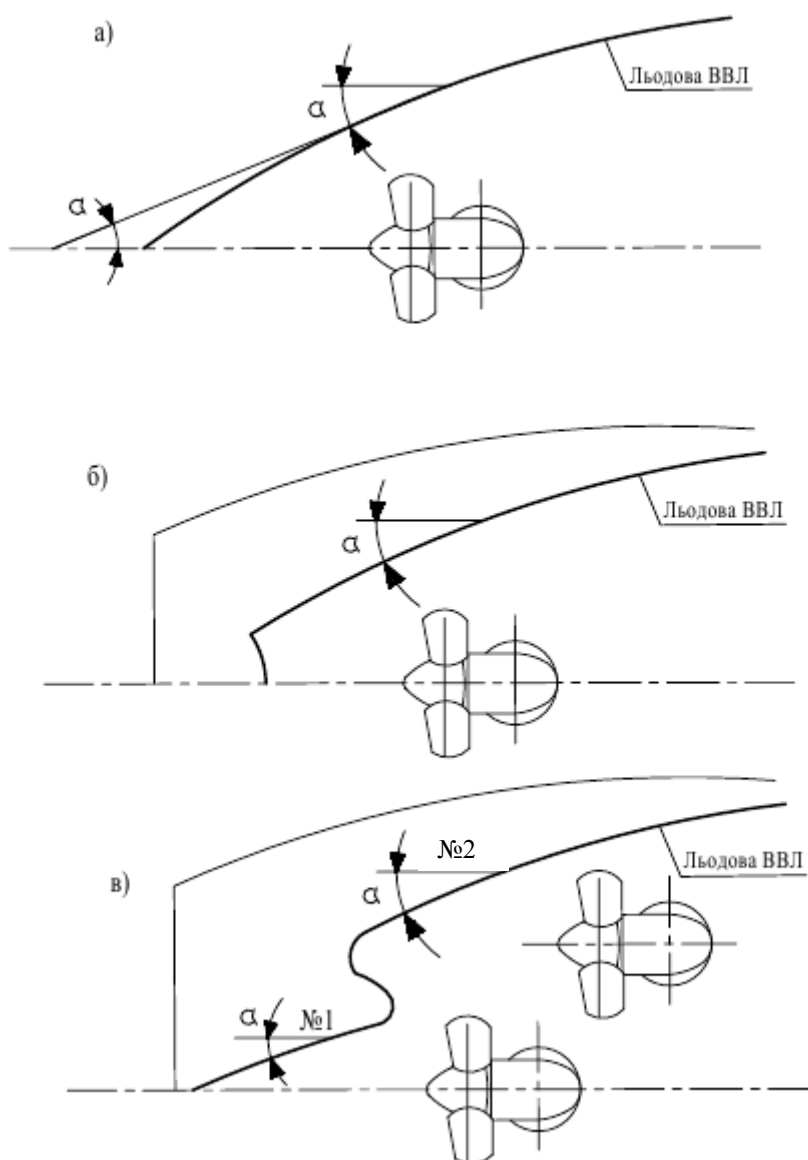

Fig. 3.14.2.4.1 Determination of the ice waterline angles in the aft of the ship:
a) one RP; б) two RPs; в) three RPs.

3.14.2.4.2 Ice pressure.

3.14.2.4.2.1 In region AI:

for ships that can run in ice both ahead and astern:

in accordance with 3.10.3.2.1, Part II «Hull»;

for ships that can run in ice only astern:

for ices classes **Ice2**, **Ice3**, **Ice4**, **Ice5** and **Ice6**:

$$p_{AI}^0 = a_4 p_{BI}, \quad (3.14.2.4.2.1-1)$$

where: a_4 – factor, as given in Table 3.10.3.2.1, Part II «Hull»;

p_{BI} – ice pressure in region **BI** (refer to 3.14.2.4.2.2);

3.14.2.4.2.2 In regions **A₁I** and **BI** – in accordance with 3.10.3.2.2 and 3.10.3.2.3, Part II «Hull» respectively. If the ice class when the ship runs ahead differs from the ice class when the ship runs astern, the factor a_3 shall correspond to the higher ice class.

3.14.2.4.2.3 In region CI:

$$p_{CI} = 2100a_1v_m(\Delta/1000)^{1/6},$$

where: a_1 – factor given in Table 3.10.3.2.1, Part II «Hull» depending on the ship's ice class;

v_m – maximum within the region value of v , determined in cross sections $x = 0; 0,025L; 0,05L; 0,075L$ respectively, from aft boundary of estimated ice waterline by the Formula:

$$v = f_v \left(b_0^v + b_1^v \frac{x}{L} + b_2^v \alpha + b_3^v \beta' \right),$$

where: b_i^v – factors given in Table 3.14.2.4.2.3 depending on the number of RPs.

Table 3.14.2.4.2.3

	b_0^v	b_1^v	b_2^v	b_3^v
One RP	0,8731	0,1537	0,0011	-0,0012
Two RPs	0,8721	0,2090	0,0009	-0,0011
Three RPs, part №1 (Fig. 3.14.2.4.1)	0,8265	0,2474	0,0011	0,0004
Three RPs, part №2 (Fig. 3.14.2.4.1)	0,8660	-0,1016	0,0010	-0,0007

3.14.2.4.2.4 In regions **II**, **III** and **IV** the ice load intensity is determined as the part of the ice load intensity of region **I** in the corresponding area lengthwise:

$$p_{kl} = a_{kl}p_k, \quad (3.14.2.4.2.4)$$

where: $k = \mathbf{A}, \mathbf{A}_1, \mathbf{B}, \mathbf{C}$;

$l = \mathbf{II}, \mathbf{III}, \mathbf{IV}$;

a_{kl} – factor given in Table 3.14.2.4.2.4.

Table 3.14.2.4.2.4

Ice class	Region lengthwise								
	Forward and intermeditae (A , A ₁)			Midship (B)			Aft (C)		
	Region depthwise								
	II	III	IV	II	III	IV	II	III	IV
Ice3	0,4	-	-	-	-	-	0,4	-	-
Ice4	0,5	0,4	0,35	0,4	-	-	0,5	0,4	0,35
Ice5	0,65	0,65	0,45	0,5	0,4	-	0,65	0,65	0,45
Ice6	0,65	0,65	0,5	0,5	0,45	-	0,65	0,65	0,5

3.14.2.4.3 Ice load distribution depth.

3.14.2.4.3.1 In regions **A**_I, **A**_{II}, **A**_{III}, **A**_{IV}:

for ships that can run in ice both ahead and astern:

in accordance with 3.10.3.3.1, Part II «Hull»;

for ships that can run in ice only astern:

for ices classes **Ice2**, **Ice3**, **Ice4**, **Ice5** and **Ice6**:

$$b_A = 0,8b_B, \quad (3.14.2.4.3.1)$$

where for b_B – refer to 3.10.3.3.3 Part II «Hull»;

3.14.2.4.3.2 In regions **A**_I, **A**_{II}, **A**_{III}, **A**_{IV} – in accordance with 3.10.3.3.2 Part II «Hull», and in regions **B**_I, **B**_{II}, **B**_{III} and **B**_{IV} – in accordance with 3.10.3.3.3 Part II «Hull».

3.14.2.4.3.3 In regions **C**_I, **C**_{II}, **C**_{III} and **C**_{IV}:

$$b_C = C_1 k_{\Delta} u_m, \quad (3.14.2.4.3.3)$$

where: C_1 and k_Δ - factors given in Table 3.10.3.3.1, Part II «Hull»;

u_m – maximum within the region value of u , determined in cross sections $x = 0; 0,025L; 0,05L; 0,075L$ respectively, from aft boundary of estimated ice wwaterline by the Formula:

$$u = f_u \left(b_0^u + b_1^u \frac{x}{L} + b_2^u \alpha + b_3^u \beta' + b_4^u \frac{x}{L} \beta' + b_5^u \alpha \beta' \right),$$

where: b_1^u – factors given in Table 3.14.2.4.2.3 depending on the number of RPs.

Table 3.14.2.4.3.3

	b_0^u	b_1^u	b_2^u	b_3^u	b_4^u	b_5^u
One RP	0,6445	1,0425	0,0035	0,0010	-0,0201	-0,0001
Two RPs	0,6584	0,8894	0,0036	0,0005	-0,0128	-0,0001
Three RPs, part №1 (Fig. 3.14.2.4.1)	0,6075	1,3355	0,0037	0,0025	-0,0225	-0,0001
Three RPs, part №2 (Fig. 3.14.2.4.1)	0,6021	1,3103	0,0040	0,0024	-0,0368	-0,0001

3.14.2.4.4 Ice load distribution length.

3.14.2.4.4.1 In regions AI, AII, AIII, AIV:

for ships that can run in ice both ahead and astern:
in accordance with 3.10.3.3.1, Part II «Hull»;

for ships that can run in ice only astern:

$$l_A^u = 6b_A \geq 3,5\sqrt{k_\Delta}, \quad (3.14.2.4.4.1)$$

where: b_A – ice load distribution depth in accordance with 3.14.2.4.3.1.

3.14.2.4.4.2 In regions A_II, A_III, A_IIII, A_IIV – in accordance with 3.10.3.3.2, Part II «Hull», and in regions BI, BII, BIII and BIV – in accordance with 3.10.3.3.3, Part II «Hull».

3.14.2.4.4.3 In regions CI, CII, CIII i CIV:

$$l_C^u = 11,3\sqrt{b_C \sin \beta_m^C} \geq 3,5\sqrt{k_\Delta}, \quad (3.14.2.4.4.3)$$

where: b_C – ice load distribution depth in accordance with 3.14.2.4.3.3;
 β_m^C –angle β in the estimated cross-section of region C, with u maximum.

3.14.2.4.5 Ice load intensity for Arctic ice class Icebreaker 1 and Icebreaker 2 ships.

3.14.2.4.5.1 In regions AI, A_II and BI the ice load intensity is determined in accordance with 3.10.3.5.1 and 3.10.3.5.2, Part II «Hull». p_{AI}^0 is determined in accordance with 3.14.2.4.2.1.

3.14.2.4.5.2 the ice load intensity in region CI is determined in accordance with 3.10.3.5.2, Part II «Hull».

3.14.2.4.5.3 In regions II, III i IV the ice load intensity is determined in accordance with 3.10.3.5.3, Part II «Hull»:

$$p_{mn} = a_{mn} \cdot p_{ml}, \quad (3.14.2.4.5.3)$$

where for a_{mn} , m , n – refer to 3.10.3.5.3, Part II «Hull».

3.14.2.4.6 The depth of ice load intensity distribution for Arctic ice class **Icebreaker 1** and **Icebreaker 2** ships in regions A, A_I and B is assumed to be the same and is determined in accordance with 3.10.3.3.1, Part II «Hull» as for the new region of ship, the ice class number of which is the same as the icebreaker ice class. In region C the depth of ice load intensity distribution is determined in accordance with 3.14.2.4.3.3 as for the aft region of ship, the ice class number of which is the same as the icebreaker ice class.

3.14.2.4.7 The length of ice load intensity distribution for Arctic ice class **Icebreaker 1** and **Icebreaker**

2 ships in regions **A**, **A₁** and **B** is assumed to be the same and is determined in accordance with **3.10.3.4.1** Part II «Hull» as for the new region of ship, the ice class number of which is the same as the icebreaker ice class. In region **C** the length of ice load intensity distribution is determined in accordance with **3.14.2.4.4.3** as for the aft region of ship, the ice class number of which is the same as the icebreaker ice class.

3.14.2.5 Scantling of ice reinforcement structures.

3.14.2.5.1 Scantling of ice reinforcement structures shall be determined in accordance with the requirements of **3.10.4**, Part II "Hull" for the ice load parameters determined in accordance with the calculation procedure described in **3.14.2.4**.

3.14.2.5.2 Scantling of keel and aft rake construction shall be determined in accordance with the requirements of **3.10.4**, Part II "Hull" for the hull constructions (shell plating, deep and web frames, longitudinals, plate structures) using the ice load parameters determined in accordance with the calculation procedure described in **3.14.2.4**.

3.15 SHIPS INTENDED FOR OPERATION IN CONDITIONS OF LOW AIR TEMPERATURE

3.15.1 GENERAL

3.15.1.1 Application.

3.15.1.1.1 The requirements for ships to ensure long-term operation at low air temperatures apply to ships designed for operation in cold climatic conditions (refer to **2.2.3.1.4**, Part I "Classification") and are additional to the requirements of this part of the Rules.

3.15.1.1.2 Ships which shall comply with the requirements of this paragraph for design temperature are provided with an additional distinguishing mark **WINTERIZATION (DAT)** (refer to **2.2.30**, Part I "Classification").

3.15.1.2 Definitions.

Design Ambient Temperature, DAT - outdoor temperature in degrees Celsius, which is used as a criterion for the selection and testing of materials and equipment that are exposed to low temperatures.

Design Structural Temperature - temperature in degrees Celsius, which is accepted for the choice of structural material. If there are no additional instructions in the Rules or in this section regarding the design temperature of the structure, the design ambient temperature is adopted.

3.15.2 DESIGN TEMPERATURES

3.15.2.1 The design ambient temperature is set by the ship-owner based on the purpose of the ship and her operating conditions.

3.15.2.2 The requirements of the Rules provide for the following standard values of the design ambient temperature: -30°C (distinguishing mark **WINTERIZATION (-30)**); -40°C (distinguishing mark **WINTERIZATION (-40)**) i -50°C (distinguishing mark **WINTERIZATION (-50)**). Application of requirements for design ambient temperatures above -30° C, as well as for intermediate values, is determined by the Register in agreement with the ship-owner.

3.15.2.3 The design ambient temperature cannot be accepted above that specified in **1.2.3.3** of this part of the Rules for the corresponding ice class of the ship.

3.15.2.4 The design temperature of the hull structures shall be taken in accordance with **1.2.3.4** of this part of the Rules. In this case design ambient temperature shall be taken as T_A .

3.16 FLOATING DOCKS

3.16.1 General.

3.16.1.1 Application.

The requirements of this Chapter apply to hull structures of wing-walled (caisson, pontoon, sectional) docks.

Caisson dock is a structure fitted with a solid pontoon and two wings continuous along the entire length and structurally inseparable (including caisson docks with end pontoons for docking a centre pontoon).

Pontoon dock is a structure fitted with two wings continuous along the entire length and several pontoons

connected to the wings by bolts, rivets, welding.

Sectional dock is a structure consisting of several sections, each section being a caisson or a pontoon dock, connected by bolts, welded plates, hinges.

The requirements apply to the docks having a ratio of the length over the pontoon deck to the breadth more than 3,5.

Other structural configurations of docks and their proportions shall be subject to calculation according to the agreed procedure.

3.16.1.2 Definitions:

Ballast water is sea water pumped into ballast compartments in order to change dock's draught and trim.

Ballast compartment is a compartment in a pontoon or wing wall of the dock, bounded by watertight structures and intended for pumping ballast water.

Dock wing wall is a part of floating dock hull structurally connected to a pontoon or pontoons and intended to provide stability when the dock is lowered and lifted; a wing wall is divided by decks, platforms, bulkheads into spaces and compartments for arranging dock equipment and ballast.

Lifting capacity of the dock Δ , in t is mass of the heaviest ship or ships that the dock shall lift in normal service.

Depth of the dock D is a vertical distance measured at the midship section from the base line to the moulded surface of the top deck at the outer wall side.

Pontoon depth D_p is a distance measured at the centreline from the base line to the moulded surface of the pontoon deck.

Maximum submersion depth $d_{m.s}$ is a vertical distance measured at the midship section from the base line to the waterline to which the dock may theoretically be lowered.

Length of dock at the pontoon deck $L_{p.d}$ is the distance measured along the pontoon deck parallel to the base line between moulded surfaces of the pontoon end bulkheads.

Length of keel blocks track L_k is a distance measured at the centreline parallel to the base line between outer ends of keel blocks.

Ship weight for docking Δ_t , in t is weight of the light ship to be docked with necessary stores and ballast to provide the ship's draught and trim as required for docking.

Rest water ballast is ballast water which pumps cannot discharge.

Design waterline is a waterline of a floating dock corresponding to its draught with full stores, a ship of a design weight and a required quantity of ballast.

Crinolines are cantilever structures of the dock, fitted at the end bulkheads of the dock pontoon at the pontoon deck level, aiming to increase an area available for docking operations at the ship's ends projecting beyond the pontoon deck.

Light draught d_l is a vertical distance measured at the midship section from the base line to the waterline corresponding to the dock displacement with no stores, docked ship and ballast.

Safety deck is a watertight deck in wing walls of the dock, forming a boundary of the ballast compartments from above.

Air cushion is an area of a higher air pressure between the top of compartment and a level of ballast water therein.

Pontoon is a part of the dock hull intended to maintain buoyancy of the dock which is defined by volumes of its compartments.

Compensating ballast water is ballast water pumped into ballast tanks in order to reduce transverse and/or longitudinal bending moments and deflections of pontoon and/or wing wall structures.

Design draught d is a vertical distance measured from the base line to the design waterline.

Pontoon deck is a deck on which keel blocks or bilge blocks are fitted.

Dry compartment is a compartment below the safety deck (or below the margin line where safety deck is omitted) not intended for pumping ballast water.

Top deck is a uppermost deck of dock wing walls.

Wall breadth at top deck $b_{t.d}$ is a distance measured normal to the centreline between the moulded surfaces of the inner and outer wall sides at the level of the moulded surface of the top deck.

Wall breadth at pontoon deck $b_{p.d}$ is a distance measured normal to the centreline between the moulded surfaces of the inner and outer wall sides at the level of the moulded surface of the pontoon deck.

Breadth of the dock B is a distance measured normal to the centre line between the moulded surfaces of the outer wall sides.

Pontoon deck breadth $B_{p.d}$ is a distance measured normal to the centre line between the lines of intersection

of moulded surfaces of the inner wall sides and the pontoon deck.

3.16.1.3 Materials:

3.16.1.3.1 When selecting steel for hull structures of floating docks, provisions of **1.2** shall be applied, having regard to subdivision of structural members into groups according to Table 3.16.1.3.1.

Table 3.16.1.3.1

Dock members	Group of members	
	within midship region	outside midship region (refer to 1.1.3)
Thickened top deck plates in way of openings; bottom plating of pontoon deck wing walls and plate strengthenings of pontoon structures in pontoon docks at sections between pontoons and in adjacent regions, plate members of sectional dock structures in way of dock section connections	III	II
Pontoon deck plating and bottom plating of pontoon (pontoons); transverse and longitudinal framing members of pontoon deck and bottom; plate structures of primary transverse members (non-tight and tight bulkheads) of pontoon (pontoons); bottom strakes of wing walls and adjacent strakes of shell plating, longitudinal bulkhead plating of pontoon docks	II	II
Plating strakes, framing members of top deck, safety deck, wing walls and pontoon shell plating; plates and framing members of wing wall interior structures (other than dock structural members referred to in 1 and 2)	II	I

3.16.1.3.2 Plate and beam items of crinolines, walkways and other secondary structures of a floating dock may be fabricated from steel having lower strength characteristics than specified in **1.2.2.1**, provided their welding is guaranteed at the shipyard.

3.16.1.4 Estimation of wear. Minimum thicknesses.

3.16.1.4.1 The effect of wear on the scantlings of structures is estimated on the basis of specification of strength to the end of the dock service life. Corrosion allowances shall permit operation of the dock during the full specified service life with average corrosion rates of structural items.

3.16.1.4.2 Scantlings and strength characteristics of structures with due regard for wear and corrosion shall be determined in compliance with 1.1.5, with a corrosion allowance Δs , in mm, being determined by the formula:

$$\Delta s = kuT, \quad (3.16.1.4.2)$$

where: k – factor taking into account zone conditions of floating dock service and equal to:

1,0 – for Baltic basin;

1,1 – for Northern, Black-and-Azov and Caspian-and-Volga basins;

1,2 – for Pacific basin;

u – average annual reduction in thickness of structural members according to Table 3.16.1.4.2, in mm/year;

T – design service life of dock; where service life is not specified, it shall be taken as $T = 50$ years.

Table 3.16.1.4.2

Nos.	Structure	u , in mm/year
1	Top deck plating and wing wall plating above margin line	0,04
2	Safety deck plating	0,08 ¹
3	Wing wall bottom of pontoon docks	0,08
4	Inner and outer wing wall plating from pontoon deck to the margin line	0,08 ¹
5	Pontoon deck plating:	
5.1	in the middle portion	0,10
5.2	in the middle portion at ends over a length $0,1L_{p,d}$	0,12
6	Side plating and outer transverse wall plating of pontoon (pontoons):	
6.1	top ($\leq 1,0$ m) and bottom ($\leq 0,5$ m) strakes	0,09 ¹
6.2	other strakes	0,08 ¹

7	Bottom plating of pontoon (pontoons)	0,08 ^{1,2}
8	Interior bulkheads of ballast compartments:	
8.1	bottom strake ($\leq 0,5$ m)	0,09
8.2	other strakes	0,08 ¹
9	Framing members, dock truss items in ballast compartments	0,10 ¹
10	Plates and framing members of internal wing structures above safety deck, top deck and wing wall framing	0,04
¹ In way of compartments heated in winter by live steam, u shall be increased by 10 %. ² For bottom plating in way of ballast system suction and discharges, u shall be increased by 15 %.		

3.16.1.4.3 Average annual thickness reduction of dock structures plates and beams, given in Table 3.16.1.4.2, shall be used when dock structures have appropriate protective paint coatings.

Specified corrosion rates may be reduced if special protective arrangements are used in agreement with the Register.

3.16.1.4.4 Thickness of primary members (including corrosion allowance) shall not be less than given in Table 3.16.1.4.4 and determined depending on the assumed spacing a .

Table 3.16.1.4.4

Structure	s_{min} , in mm	Remarks
Plating of outer structures other than pontoon deck; structural items in ballast compartments and tanks, including framing members	7,5	$a < 0,6$ m
	$7,5 + 10 \cdot (a - 0,6)$	$a \leq 0,75$ m
	$8 + 6,5 \cdot (a - 0,6)$	$a > 0,75$ m
Pontoon deck plating	9,0	$a < 0,6$ m
	$9 + 13 \cdot (a - 0,6)$	$a \leq 0,75$ m
	$10 + 6 \cdot (a - 0,6)$	$a > 0,75$ m
Top deck plating; plates and beams of structures above safety deck	$6,5 + 8 \cdot (a - 0,6)$	$a \geq 0,6$ m
	6,5	$a < 0,6$ m

3.16.1.5 Guidelines on design of floating dock structures.

When designing floating dock structures, the following sequence is recommended:

- .1 execution of structural layout of pontoon (pontoons) and wing walls (refer to **3.16.2**);
- .2 determination of design loads resulting in local and longitudinal deflection of dock hull structures (refer to **3.16.3**);
- .3 design of plate items and framing members of dock structures on the basis of local strength and buckling, having regard to minimum thickness restrictions;
- .4 design of structures which provide both transverse and longitudinal strength of dock pontoon. Values of structural parameters obtained in implementation of **3.16.1.5.3**, are used here as initial data;
- .5 design of dock hull structures which provide dock longitudinal strength under design operating conditions (docking operations). Values of structural parameters obtained in implementation of **3.16.1.5.3** and **3.16.1.5.4**, are used here as initial data;
- .6 design of structures, having regard to the requirements for strengthening (e.g. wing wall decks and sides in way of openings, engine room, etc.);
- .7 check calculations of both longitudinal and transverse, as well as local strength of hull structures under conditions of real ship docking;
- .8 check calculations of both longitudinal and transverse, as well as local strength of dock structures during passage from a place of build to a place of operation. Development of recommendations on dock structure strengthening.

3.16.2 Construction.

3.16.2.1 Framing systems of pontoon (pontoons) and wing walls.

For pontoon (pontoons) of caisson, pontoon and sectional docks transverse framing is preferable.

Wing wall sides and decks of pontoon docks with lifting capacities of 10 000 t and above shall be longitudinally framed; docks having lifting capacities below 10 000 t may be framed transversely.

Wing wall sides and decks of caisson docks above the safety deck shall be longitudinally framed, wing wall sides below the safety deck may be transversely framed.

For pontoon bottom plating portions of caisson docks in way of wing walls a longitudinal framing may be adopted.

For transverse and longitudinal bulkheads of the pontoon and wing walls structures with horizontal and vertical stiffeners are permitted.

Truss arrangements may be used in the pontoon (pontoons) and wing walls.

3.16.2.2 Structural layout of pontoons.

Plate and beam structures of the pontoon shall maintain local strength of the appropriate pontoon structures (pontoon deck, bottom, longitudinal and transverse bulkheads, etc.), as well as transverse strength of the pontoon.

Spacing of primary longitudinal and transverse framing members of the pontoon shall be determined according to 1.1.3 with $L = L_{p,d}$.

Primary transverse structures of the pontoon (pontoons), i.e. non-tight bulkheads, shall be fitted in 3 to 7 spacings, but they shall not be spaced more than $(B - B_{p,d})/6$ apart.

A centreline bulkhead shall be fitted under the keel blocks. A box structure formed by two longitudinal bulkheads arranged symmetrically on each side of the centre line may be used in lieu of the centre line bulkhead.

Bulkheads or girders shall be aligned with inner wall sides.

Where transverse framing is adopted for a pontoon (pontoons), additional primary longitudinal supporting members may be fitted to limit a span of transverse members of the bottom and pontoon deck. They shall be spaced not more than 3 to 5 spacings apart.

3.16.2.3 Structural layout of wing walls.

Spacing of primary longitudinal and transverse framing members of wing walls shall be determined as required by 1.1.3.

Where wall sides and decks are longitudinally framed, deck transverses and web frames shall be aligned with primary transverse structures of the pontoon (pontoons) (refer to 3.16.2.2).

Where wall sides are transversely framed, side stringers shall be fitted. Spacing of stringers and distance between stringers and deck shall, in general, not exceed 3,5 m.

Where transverse framing is adopted for wing walls below the safety deck it is advisable to provide web frames on wall sides in line with primary transverse structures of the pontoon, and deck transverses on the safety deck plating.

Primary supporting members of outer and inner wall sides below the safety deck (web frames with longitudinal framing and side stringers with transverse framing) shall be connected by cross ties which shall be fitted in line with each primary transverse of the pontoon (refer to 3.16.2.2).

3.16.2.4 Additional provisions.

Use of butt-lap connections for girders and transverses of pontoon (pontoons) and wing walls is permitted.

Where proper quality control of welding joints is provided, assembling joints aligned on plate structures and framing members are permitted.

Hollow square and tubular cross ties and struts shall not be used in ballast compartments and other tanks.

3.16.3 Design loads.

3.16.3.1 Loads for structure design based on local strength.

3.16.3.1.1 Design pressure p , in kPa, for plate and beam bottom structures shall be determined by the formulae:

in way of dry compartments

$$p = 10d_{m,s}; \quad (3.16.3.1.1-1)$$

in way of ballast compartments not communicated with wing walls

$$p = 10(d_{m,s} - D_p); \quad (3.16.3.1.1-2)$$

and communicated with wing walls

$$p = 10(d_{m,s} - z_{s,d} + \Delta z), \quad (3.16.3.1.1-3)$$

where: $z_{s,d}$ – distance of the safety deck from the base line, in m;

Δz – thickness of air cushion, in m;

for D_p , $d_{m,s}$ – refer to 3.16.1.2.

3.16.3.1.2 Design pressure p , in kPa, for plate and beam structures of the pontoon deck in way of dry and ballast compartments shall be determined by Formula (3.16.3.1.1-2).

3.16.3.1.3 Design pressure p , in kPa, for plate and beam structures of pontoon sides and end bulkheads shall be determined by the following formulae:

in way of dry compartments

$$p = 10(d_{m.s} - z_i), \quad (3.16.3.1.3-1)$$

where: z_i – distance of the lower edge of the plate or midspan of the framing member from the base line, in m;

in way of ballast compartments

$$p = 10(d_0 - D_p), \quad (3.16.3.1.3-2)$$

where: d_0 – depth of the dock corresponding to filling of a side ballast compartment up to the safety deck, in m; d_0 shall not be taken more than $d_{m.s}$.

As the first approximation, where no special information is available, it may be assumed that:

$$d_0 = D_p + G/2L_{p,d}b_{p,d}\rho,$$

where: G – mass of dock without rest water and compensating ballast;

ρ – sea water density (refer to 1.1.3);

For D_p , $d_{m.s}$, $L_{p,d}$, $b_{p,d}$ – refer to 3.16.1.2.

3.16.3.1.4 Design pressure p , in kPa, for plate and beam structures of wall sides and end bulkheads shall be determined by the following formulae

in way of dry compartments, using Formula (3.16.3.1.3-1);

in way of ballast compartments

$$p = 10(d_0 - z_i), \quad (3.16.3.1.4)$$

where for z_i , d_0 – refer to 3.16.3.1.3.

3.16.3.1.5 Design pressure p , in kPa, for plate and beam structures of the safety deck in way of dry compartments shall be taken equal to 5 kPa; in way of ballast compartments p shall be determined by the formula

$$p = 10(d_{m.s} - z_{s,d} + \Delta z), \quad (3.16.3.1.5)$$

for $z_{s,d}$, Δz , $d_{m.s}$ – refer to 3.16.3.1.1.

3.16.3.1.6 Design pressure p , in kPa, for plate and beam structures of inner watertight bulkheads of ballast compartments shall be determined by the formula

$$p = 10(d_{m.s} - z_t + \Delta z), \quad (3.16.3.1.6)$$

where: z_t – distance of ballast compartment top from the base line, in m;

Δz , d_m – as defined in 3.16.3.1.1.

3.16.3.1.7 Design pressure p , in kPa, for plate and beam structures of main watertight bulkheads shall be determined by Formula (3.16.3.1.3-1).

3.16.3.1.8 Design pressure for plate and beam structures of the top deck shall be equal to 5 kPa.

3.16.3.1.9 Design pressure p , in kPa, for plate and beam structures of fuel oil, lubricating oil, water and

other tanks is determined by the following formulae:

when internal pressure is calculated

$$p = 10\rho_1(z_{a,p} - z_i), \quad (3.16.3.1.9)$$

where: ρ_1 – density of liquid contained in the tank, in t/m³;

$z_{a,p}$ – distance of the upper edge of the air pipe from the base line, in m;

when external pressure is calculated, Formula (3.16.3.1.3-1) shall be used;

for z_i – refer to **3.16.3.1.3**.

For plate structures arranged parallel to the base line, z_i is a distance of the plate structure from the base line.

3.16.3.1.10 Design pressure on crinoline structures is assumed to be equal to 5 kPa.

3.16.3.1.11 Design pressure on walkway structures is assumed to be equal to 3,5 kPa.

3.16.3.1.12 Design pressure on structures of safety deck, intermediate deck and platforms where equipment of the electric generating plant is arranged are assumed equal to 18 kPa; in way of accommodation and service spaces, 5 kPa.

3.16.3.2 Loads for structure design based on both transverse and longitudinal strength of pontoon (pontoons).

3.16.3.2.1 Design loads to be used in design of pontoon structures of caisson, pontoon and sectional docks shall be calculated for the condition when the ship of length L_s and weight equal to the maximum lifting capacity of the dock Δ is supported on the keel blocks symmetrically about the midship section of the dock. The draught of the dock shall correspond to the design one (refer to **3.16.1.2**), ballast water is considered evenly distributed over the length and breadth of the dock.

3.16.3.2.2 For pontoon and sectional docks an additional condition shall be considered for pontoons loaded by buoyancy forces the value of which corresponds to the condition specified in **3.16.3.2.1**, corrected for rest-water counterpressure and gravitational forces of light-dock weight components, opposite in direction.

Where no initial data are available, buoyancy force p , in kPa, may be determined by the formula

$$p = g\Delta / [B L_s - (n - 1)Ba_0], \quad (3.16.3.2.2)$$

where: n – number of pontoons of pontoon docks or sections of sectional docks;

a_0 – distance between pontoons or sections, in m;

B, L_s, Δ - as defined in **3.16.1.2**.

3.16.3.2.3 Design length of the ship L_s shall be assumed equal to the length of the shortest ship whose docking weight is equal to the maximum lifting capacity of the dock, but not more than $0,9L_{p.d}$. For docks having lifting capacity more than 40 000 t, the design length of the ship L_s shall not be taken less than $0,9L_{p.d}$.

3.16.3.2.4 The weight curve of the ship shall be taken as a rectangle with a superimposed parabola of half the area of the rectangle. Linear docking load q_x , in kN/m, at the section distant at x forward and aft from the midship section shall be determined by the formula

$$q_x = \frac{g\Delta}{L_s\varphi} \left[-3(1-\varphi)(2x/L_s)^2 \right], \quad (3.16.3.2.4)$$

where φ – block coefficient of ship weight curve.

For docks of 40 000 t lifting capacity and less block coefficient of the ship weight curve shall be assumed depending on a design ship type according to Table 3.16.3.2.4.

For docks above 40 000 t lifting capacity, $\varphi = 0,8$ shall be assumed.

Table 3.16.3.2.4

Type of ship	φ
Icebreakers Ships with engine room aft or semi-aft	0,67
Ships with engine room amidships	0,75 ÷ 0,8
Ships with engine room aft or semi-aft	1,0

3.16.3.2.5 Where it is intended to lift ships simultaneously on keel and side blocks, as well as where different cases of simultaneous docking of several ships are expected, they shall be taken into account in design of structures which provide both longitudinal and transverse strength of the pontoon. Design loads shall be determined using the procedures approved by the Register.

3.16.3.2.6 Design loads on end pontoons of pontoon and sectional docks or on the end portions of caisson docks and when ships with overhung ends are docked shall be specially considered by the Register.

3.16.3.3 Loads for design of structures based on longitudinal strength.

3.16.3.3.1 Design loads shall be determined for the following conditions:

dock's sagging when a ship having the shortest length L_s expected and a weight equal to the maximum lifting capacity of the dock Δ is lifted;

dock's hogging when a ship having the largest length L_s expected and a weight equal to the maximum lifting capacity of the dock Δ is lifted, or two or more ships installed in line and having a total weight equal to Δ are docked.

Ballast water is considered to be evenly distributed over the entire length of the dock.

3.16.3.3.2 The form of ship weight curve is determined by Formula (3.16.3.2.4).

3.16.3.3.3 The design length of the shortest ship shall be as required by **3.16.3.2.3**.

The design length of the largest ship or a total length of several ships installed in line over the length of the dock shall not be less than $1,3L_{p.d.}$

3.16.3.3.4 The design block coefficient of the ship weight curve shall be assigned according to **3.16.3.2.4**, for hogging, $\varphi = 1,0$ shall be taken, unless expressly provided otherwise.

3.16.4 Scantlings of structural members.

3.16.4.1 The thickness requirements for plate structures based on local strength.

The plating thicknesses of pontoon (pontoons), wall sides, interior and outer watertight bulkheads, decks and platforms shall be determined by Formula (1.6.4.4) with $m = 22,4$ and $k_{\sigma} = 1,8$. A corrosion allowance shall be obtained according to the recommendations given in **3.16.1.4**. The design transverse pressure p is specified in **3.16.3.1**.

3.16.4.2 Scantling requirements for framing members based on local strength.

3.16.4.2.1 The section modulus of primary members shall be determined as required by **1.6.4.1**.

3.16.4.2.2 The net sectional area of girders and transverses, as well as sectional area of beams and longitudinals having a relationship $l/h \leq 10$ (where l – design span, in m; h = web depth of a beam or longitudinal, in cm) shall be obtained from **1.6.4.3**.

3.16.4.2.3 The design pressure p shall be determined at a mid-span of framing members as required by **3.16.3.1**.

3.16.4.2.4 The design span l of framing members shall be selected in accordance with **1.6.3.1**.

3.16.4.2.5 Coefficients of permissible normal and shear stresses specified in 1.6.4.1 and 1.6.4.3 shall be assumed equal to $k_{\sigma} = 0,8$ and $k_{\tau} = 0,8$.

3.16.4.2.6 The factor ω_c , which takes account of framing member wear as given in 1.1.5.3 shall be taken with Δ_s according to **3.16.1.4**.

3.16.4.2.7 Factors of design bending moments m and shear forces n shall be assumed as follows:

$m = 12$ and $n = 0,5$ – for bottom transverse and longitudinal members, beams and longitudinals of the pontoon deck; for stiffeners of watertight transverse bulkheads with longitudinally framed bottom and pontoon deck; for stiffeners of interior watertight longitudinal bulkheads with transversely framed bottom and pontoon deck; for longitudinal framing members of wall sides and decks; for safety deck beams with transversely framed wall sides below the safety deck; for girders and transverses of bottom and pontoon deck and side stringers of outer and inner wall sides;

$m = 8$ and $n = 0,5$ for stiffeners of watertight transverse bulkheads with transversely framed bottom and pontoon deck; for stiffeners of interior longitudinal bulkheads with longitudinally framed bottom and pontoon deck; for horizontal stiffeners of watertight transverse bulkheads of wing walls with transversely framed wall sides; for safety deck beams with longitudinally framed wall sides;

$m = 13$ and $n = 0,5$ – for wall deck and platform beams with transversely framed wall sides below the considered deck or platform; top deck or safety deck transverses;

$m = 11$ and $n = 0,6$ – for frames and web frames of the pontoon (pontoons), outer and inner wall sides.

3.16.4.2.8 The scantlings and structures of girders and transverses of the pontoon and wing walls shall satisfy the requirements of **1.7.3.3**. For girders and transverses of the wing walls above the safety deck the requirements

for similar structures of dry cargo ships may be applied.

3.16.4.3 Requirements for cross ties, struts and braces.

3.16.4.3.1 The sectional area of cross ties and struts S , in cm^2 , shall not be less than determined by a successive approximation method using Formula (2.9.4.1) with a design load $P = 0,5 \cdot (P_1 + P_2)$, in kN, and factor $k = 1,15$ (where $P_1 = p_1ac$, $P_2 = p_2ac$ – are maximum compressive forces acting at the ends of struts and cross ties; p_1 and p_2 are design pressures (refer to 3.16.3.1), in kPa; a – distance between members supported by struts or cross ties, in m; c is half-sum of span lengths on each side of the strut or cross tie under consideration, in m).

As a first approximation, S may be taken as

$$S = 0,11P,$$

and the radius of gyration $i = \sqrt{I/S}$, in cm, may be estimated for a suitable section having this area (where I – minimum central moment of inertia, cm^4).

If the area determined by Formula (2.9.4.1) using this radius of gyration differs by more than 10 % from the first approximation, a second approximation calculation shall be made. The radius of gyration shall correspond to the mean area of the first and second approximation.

3.16.4.3.2 The web plates of cross ties and struts of channel or I sections shall be so selected that the ratio of the breadth to the thickness shall not exceed $42l/i$ or 40, whichever is the greater (where l is length of a cross tie or strut, in m).

For ordinary angle or channel sections, the ratio of the breadth to the thickness of the flanges shall not exceed $14l/i$ or 13, whichever is the greater.

For cross ties of fabricated sections or I sections cross ties, the ratio of the breadth to the thickness of face plates shall not exceed $28l/i$ or 25, whichever is the greater.

The thickness of cross tie or strut items shall not be less than 7,5 mm.

3.16.4.3.3 The scantlings of trusses shall be determined according to a procedure approved by the Register.

3.16.4.4 Additional local strength requirements for plates and beams.

If hull structures of the dock are subjected to the loads not covered by 3.16.3.1, the scantlings of plates and beams shall be determined using the procedures approved by the Register.

3.16.4.5 Scantling requirements for primary transverse and longitudinal members of pontoon (pontoons).

3.16.4.5.1 The section modulus W , in cm^3 , of the primary transverse and longitudinal members of the pontoon (pontoons) shall be determined by the formula

$$W = W' + \Delta W, \quad (3.16.4.5.1-1)$$

where: W' – required section modulus of the end of the dock service life to be determined by the formula:

$$W' = M \cdot 10^3 / (k_\sigma \sigma_n), \quad (3.16.4.5.1-2)$$

M – design bending moment, in kN.m (refer also to 3.16.4.5.6);

ΔW – corrosion allowance to the section modulus to be determined by the formula

$$\Delta W = 100h \left[\Delta f_d + \frac{\Delta f_w}{6} (2 - \beta) \right], \quad (3.16.4.5.1-3)$$

where: h – web depth of members of the section under consideration, in m,

Δf_d , Δf_w – additions to the upper flange and web area of members, respectively, including corrosion allowances as based on the entire service life of the dock, in cm^2 , determined by the formulae:

$$\Delta f_d = 10 \Delta s_d b_{e,f} + \Delta f_{fr};$$

$$\Delta f_w = 10 \Delta s_w h;$$

$\Delta s_{d(w)} = u_{d(w)} T$ – reduction, in mm, of the plating thickness of the pontoon deck (member web) due to wear during service life of the dock T (years) with corrosion rate $u_{d(w)}$, in mm/year, according to Table 3.16.1.4.2;

$b_{e,f}$ – width of the effective flange (refer to 3.16.4.5.5), in m;

Δf_{fr} – addition to the flange area of the member allowing for corrosion wear of framing members, to be taken as: for framing members of tee sections or flat

$$\Delta f_{fr} = 0,1n(b_0+h_0)u_{fr}T; \quad (3.16.4.5.1-4)$$

for framing members of bulb flat

$$\Delta f_{fr} = 0,86nf_0u_{fr}T/s_0; \quad (3.16.4.5.1-5)$$

when addition Δf_{fr} is determined, results obtained in design of framing members based on local strength (refer to **3.16.4.2**) are used. Where the sectional area of members does not include primary members, $\Delta f_{fr} = 0$;

n – number of primary members over the breadth $b_{e,f}$;

b_0 and h_0 – face plate width and web depth of T-beam, respectively (for members of flat, $b_0=0$), in cm;

f_0 – area of isolated section;

s_0 – web thickness of bulb flat;

u_{fr} , specified corrosion rate for framing members of ballast compartments (refer to Table 3.16.1.4.2), in mm/year;

β – factor dependent on web areas f'_w , of the upper f'_a and lower f'_b face plates, having regard to wear to the end of the service life, to be determined by the formula

$$\beta = (2f'_a + f'_w) / (2f'_a + f'_w); \quad (3.16.4.5.1-6)$$

$\beta = 1,0$ – as a first approximation.

3.16.4.5.2 The sectional area of the web f_w , in cm², of primary transverse members of the pontoon (pontoons) shall be determined by the formula

$$f_w = f'_w + \Delta f_w, \quad (3.16.4.5.2-1)$$

where: f'_w – specified sectional area, in cm², of the web to the end of the service life of the dock, to be determined by the formula

$$f'_w = 10N_x / (k\tau\tau_n); \quad (3.16.4.5.2-2)$$

where: N_x – designed shear force (refer to **3.16.4.5.7**), in kN;

for Δf_w – refer to **3.16.4.5.1**.

3.16.4.5.3 The scantlings of the truss (struts and braces) of the pontoon (pontoons) shall be adequate to take shear forces arising in longitudinal bending of the pontoon.

3.16.4.5.4 To be included in the design section of primary transverse members of the pontoon (pontoons) are all structural items which are continuous between the pontoon sides; design section of primary longitudinal members shall include all structural items which are continuous between the end bulkheads of the pontoon.

3.16.4.5.5 The width of the effective flanges of the primary transverse members $b_{e,f}$, in m, of the bottom and pontoon deck plating shall be taken as

$$b_{e,f} = \min\{(B - b_{p,d})/6; c\}, \quad (3.16.4.5.5)$$

where c – average distance between the member under consideration and members on the right and on the left thereof, in m.

3.16.4.5.6 The design bending moments M_x and M_y , in kN. m, acting in transverse and longitudinal members at the middle of a continuous pontoon of a caisson dock (refer to Fig. 3.16.4.5.6-1) for the cases referred to in **3.16.3.2**, shall be determined by the formulae:

$$M_x = q(B - b_{p,d}) c_x \delta_1; \quad (3.16.4.5.6-1)$$

$$M_y = q(B - b_{p,d}) c_y \delta_2, \quad (3.16.4.5.6-2)$$

where: $q = g\Delta/L_s$ – average value of the linear load of the dock, in kN/m (L_s , Δ as defined in **3.16.3.2**);

B , $b_{p,d}$ – breadth of the dock and wing wall at the pontoon deck level;

c_x i c_y – distance between primary transverse and longitudinal members of the pontoon, respectively, as shown in Fig. 3.16.4.5.6-1, in m;

δ_1 , δ_2 – factors to be obtained from the diagrams given in Fig. 3.16.4.5.6-2 and 3.16.4.5.6-3 as dependent on parameters $L_s / L_{p,d}$, $n = L_{p,d} / (B - b_{p,d})$ and φ .

For pontoon and sectional docks, the design bending moment in design of primary transverse members M_x , in kN. m, shall be equal to the greater of the two values

$$M_x = 0,25q \frac{c_x}{\varphi} (B - b_{p.d.})(1 - 0,5\varphi \frac{L_s}{L_{p.d.}} \frac{B - b_{p.d.}}{B}); \tag{3.16.4.5.6-3}$$

$$M_x = 0,125pc_x(B - b_{p.d.})^2 \tag{3.16.4.5.6-4}$$

where for p – refer to 3.16.3.2.2.

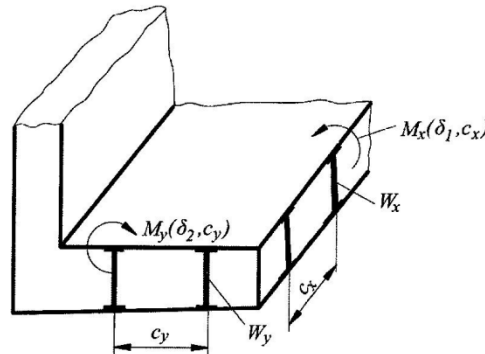

Fig.3.16.4.5.6-1

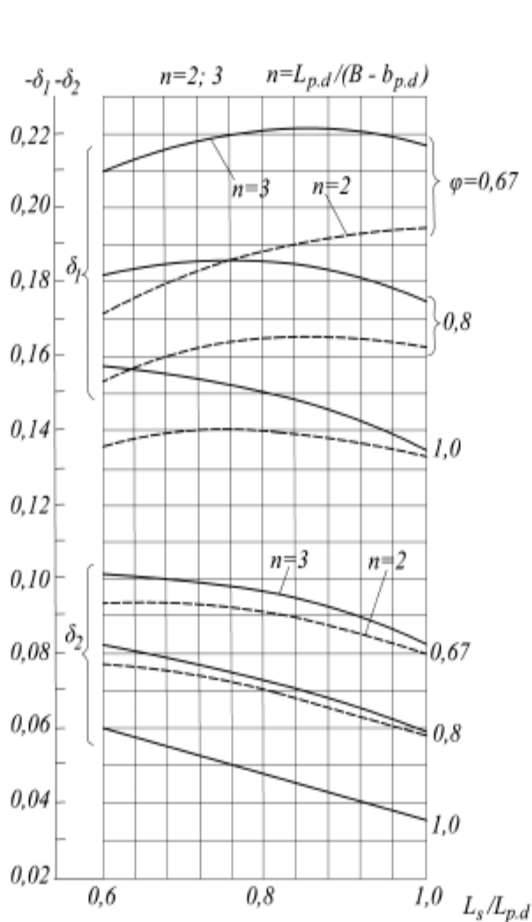

Fig.3.16.4.5.6-2

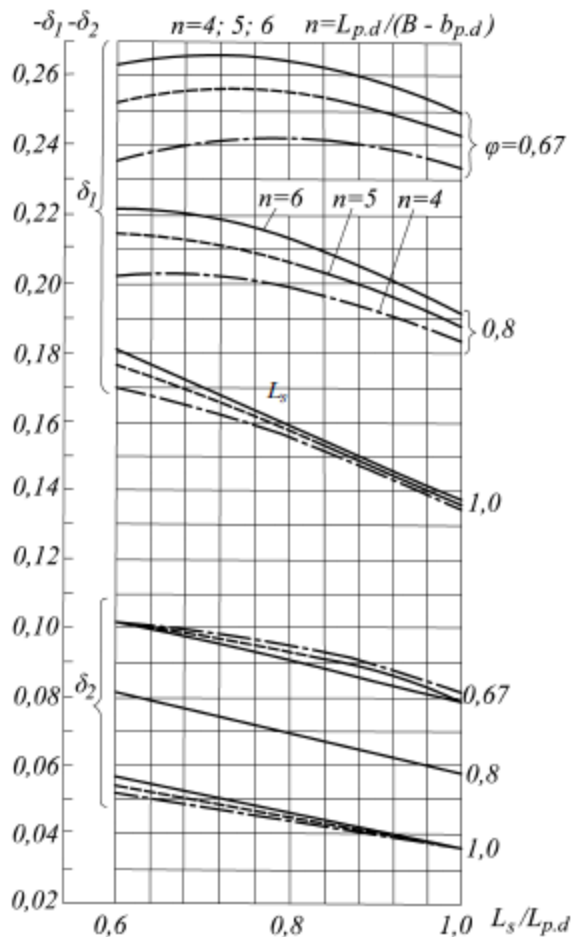

Fig.3.16.4.5.6-3

3.16.4.5.7 The design shear force N_x , in kN, taken by a transverse member of the dock (primary transverse member, or struts and braces of the pontoon truss) shall be determined by the formula

$$N_x = 0,75 \frac{g\Delta}{L_s} (1 - 1,33 \frac{L_s}{L_{p.d.}} \frac{y}{B}) c$$

(3.16.4.5.7-1)

where: y – distance of the section under consideration from the centreline of the dock, in m;

c – distance between the members under consideration, in m.

In design of the primary transverse members or struts and braces of the pontoon trusses of pontoon and sectional docks, the design shear force N_x , in kN, shall not be taken less than

$$N_x = pcy, \quad (3.16.4.5.7-2)$$

where p – as defined in 3.16.3.2.2.

3.16.4.5.8 The coefficients of permissible stresses in Formulae (3.16.4.5.1-2) and (3.16.4.5.2-2) in design of primary transverse members of the pontoon (pontoons) shall be taken as follows: $k_\sigma = 0,85$; $k_\tau = 0,8$.

Guidelines on the selection of permissible normal stresses in primary longitudinal members of the pontoon of caisson-type docks are given in 3.16.4.6.4.

3.16.4.5.9 The web thickness of primary transverse members shall meet the buckling strength requirements under the action of shear and normal stresses arising in transverse bending of the pontoon (pontoons).

The plating thickness of the pontoon deck and bottom shall meet the requirements for buckling strength under the action of compressive stresses arising in transverse bending of the pontoon (pontoons).

3.16.4.5.10 Buckling strength conditions shall comply with 1.6.5.2 and 1.6.5.3. Factor k in Formula (1.6.5.2) is taken equal to 0,75.

When Euler's stresses are determined according to the formulae given in 1.6.5.5 it shall be taken that $s' = s - \Delta s$, where Δs is obtained in compliance with 3.16.1.4.

3.16.4.6 The scantling requirements for structures based on strength and buckling conditions in longitudinal bending.

3.16.4.6.1 The assumed scantlings of dock longitudinal structures (with regard to the provisions of 3.16.4.6.2) shall provide the required hull section modulus of the floating dock.

The hull section modulus W , in cm³, of a floating dock shall not be less than

$$W = W' \omega_c. \quad (3.16.4.6.1-1)$$

where: W' – required section modulus to the end of the service life of the dock, in cm³, determined by the formula

$$W' = M \cdot 10^3 / (k_\sigma \sigma_n), \quad (3.16.4.6.1-2)$$

where: M – maximum bending moment determined by Formula (3.1c.4.6.3), in kN·m;

ω_c – factor which takes account of corrosion allowance to the section modulus for wear determined by the formula

$$\omega_c = \left[1 - F^{-1} \sum_i \Delta f_i \varphi_i \right]^{-1}; \quad (3.16.4.6.1-3)$$

F – sectional area of the floating dock hull, in cm², corresponding to the required section modulus;

Δf_i – addition to the sectional area of the i -th plate strake, which takes account of corrosion allowance to be determined by the formula

$$\Delta f_i = 10 \Delta s_i b_i, \quad (3.16.4.6.1-4)$$

$\Delta s_i = u_i T$ – thickness reduction of the i -th plate member due to wear during service life T (years), with a corrosion rate u_i , in mm/year, taken according to Table 3.12.1.4.2, in mm;

b_i – width of the i -th member, in m.

Additions to the sectional area of the floating dock hull which take account of corrosive wear of framing members shall be not less than those determined by the following formulae:

for framing members of tee sections or flat

$$\Delta f_i^* = 0,1 n_i (b_{0i} + h_{0i}) u_{fi} T, \quad (3.16.4.6.1-5)$$

where: n_i – number of framing members of the i -th group;

b_{0i} , h_{0i} – face plate width and web depth of T-beam, respectively, in cm (for members of flat, $b_{0i} = 0$);

for framing members of bulb flat

$$\Delta f_i = 0,86n_i f_{0i} u_{fri} T / s_{0i}, \quad (3.16.4.6.1-6)$$

where: f_{0i} – sectional area of bulb flat section proper, in cm^2 ;

u_{fri} – corrosion rate of framing members of the i -th group, in mm/year;

s_{0i} – web thickness of bulb flat;

φ_i – multiplier taking account of the effect of changing sectional area of the i -th member on the section modulus W , to be determined by the formula

$$\varphi_i = c_i^2 (F/I) + c_i / z_0, \quad (3.16.4.6.1-7)$$

where: I – hull inertia moment, in cm^2/m^2 , of the dock, corresponding to the required section modulus;

z_0, c_i – distance of the point at the level of which section modulus is determined and centre of gravity of sectional area of the i -th member (i -th group of longitudinal members) from the neutral axis, the position of which corresponds to W and I ; in determination of z_0 and c_i their sign shall be taken into account: positive downwards and negative upwards from the neutral axis.

3.16.4.6.2 Wing wall and pontoon longitudinals continuous in the middle region of the dock shall be included in the design cross-section of a caisson-type floating dock.

To be included in the design section of a pontoon dock are wing wall longitudinals continuous in the middle region of the dock.

3.16.4.6.3 The design bending moment M , in kNm, shall be determined for the cases referred to in 3.16.4.3, by the formula

$$M = -0,125q\Delta L_{p,d} \left(1 - \frac{3\varphi - 1}{2\varphi} \frac{L_s}{L_{p,d}} \right) \quad (3.16.4.6.3)$$

Рекомендації щодо вибору розрахункових значень φ and L_s are given in 3.16.3.3.2.

3.16.4.6.4 The coefficient of permissible stresses due to longitudinal bending referred to in Formula (3.16.4.6.1-2) shall be taken as $k_\sigma = 1,0$.

3.16.4.6.5 For caisson-type docks the following condition shall be fulfilled:

$$\sigma_1 + \sigma_2 \leq k_\sigma \sigma_n, \quad (3.16.4.6.5-1)$$

where e : σ_1 – stresses in primary longitudinal members of the pontoon due to longitudinal bending of the dock;

σ_2 – stresses in primary longitudinal members of the pontoon due to longitudinal bending of the pontoon.

Stresses σ_1 , in MPa, shall be determined by the formula:

$$\sigma_1 = Mz \cdot 10^5 / I', \quad (3.16.4.6.5-2)$$

where: M – as defined in 3.16.4.6.3;

z – distance of the point under consideration from the neutral axis of the dock, in m;

I' – inertia moment of the dock to the end of the service life, in cm^4 .

Stresses σ_2 , in MPa, shall be determined by the formula:

$$\sigma_2 = M_y z' \cdot 10^5 / I_y', \quad (3.16.4.6.5-3)$$

where M_y – as defined in 3.16.4.5.6;

z' – distance of the point under consideration from the neutral axis of the section of the primary longitudinal, in m;

I_y' – inertia moment of primary longitudinal, determined with regard to the wear of the members to the end of the service life of the dock and provisions of 3.16.4.5.4, in cm^4 .

3.16.4.6.6 In design of the dock hull, the requirements for buckling strength under the action of longitudinal bending of plate structures, girders and longitudinals, such as wall sides and deck plating, shell plating, longitudinal bulkhead plating of the pontoon and pontoon deck plating of caisson-type docks, bottom

shell of pontoon dock wings shall be met in the middle region within $0,4L_{p.d.}$

The scantlings of top deck beams where transverse framing is adopted, top deck transverses in case of longitudinal framing shall be adequate to provide buckling strength of deck structure portions between deck girders, deck girders and wall sides or between wall sides where deck girders are omitted.

3.16.4.6.7 The design compressive stresses σ_{c_i} , in MPa, obtained in estimation of the buckling strength shall be not less than:

$$\sigma_{c_i} = \frac{M}{I'} z_i \cdot 10^5, \quad (3.16.4.6.7-1)$$

where: M – design bending moment causing the compression of the i -th member under consideration (refer to **3.16.4.6.3**), in kNm;

I' – actual central inertia moment of the hull girder with regard to wear to the end of the service life, in cm^4 ;

z_i – distance of the member under consideration from the neutral axis, in m (z_i is measured from the edge most distant from the neutral axis for a plate structure; from the middle of the thickness of the effective flange for a beam member of the deck and bottom; from the middle of the thickness of the beam web for a beam of the wall side, side plating and longitudinal bulkhead of the pontoon).

As a first approximation I' , in cm^4 , may be determined by the formula:

$$I' = W'_d (D_0 - e) \cdot 10^2, \quad (3.16.4.6.7-2)$$

where: W'_d – required section modulus of the hull girder at a level of the lower edge of the top deck plating determined according to the requirements of, in cm^3 ;

D_0 – depth of wing walls (for pontoon docks), in m;

$D_0 = D$ – for caisson-type docks;

e – distance of the neutral axis from the base line for caisson-type docks; distance of the neutral axis from the abutment line of the pontoon deck to the inner wall sides for pontoon docks, in m.

As a first approximation, it may be assumed that:

$e = 0,32D$ – for caisson-type docks;

$e = 0,5D_0$ – for pontoon docks;

3.16.4.6.8 The buckling strength conditions shall comply with **1.6.5.2** and **1.6.5.3**. Factor k in Formula (1.6.5.2-1) shall be taken equal to 0,8 for the top deck plating and wall sides; for the bottom and side plating of the pontoon and pontoon deck plating of caisson-type docks, girders and longitudinals.

3.16.4.6.9 Euler stresses for plate structures shall be determined according to **1.6.5.5**, and for girders and longitudinals as required by **1.6.5.4** taking $s' = s - \Delta s$, where Δs is obtained as given in **3.16.1.4**.

3.16.4.6.10 The inertia moment of beams of the transversely framed top deck shall meet the requirements of **2.6.4.3**.

The inertia moment of top deck transverses shall be as required by **2.6.4.9**.

3.16.4.6.11 The assumed scantlings of wing wall structures shall provide buckling strength in simple bending of the wing wall in design cases of dock sagging. The procedure of supporting buckling strength in simple bending shall be agreed with the Register.

3.16.4.7 Requirements for dock towing.

3.16.4.7.1 The minimum section modulus W_{\min} , in cm^3 , required to ensure the strength of the dock during towing shall be determined by the formula:

$$W_{\min} = \frac{M}{\sigma_{perm}} \cdot 10^3, \quad (3.16.4.7.1-1)$$

where: M – design bending moment, in $\text{kN} \cdot \text{m}$, determined by the formula:

$$M = 5,03 k_w h_d B L_{p,d}^2, \quad (3.16.4.7.1-2)$$

where: k_w – factor of wave bending moment determined by the formula:

$$k_w = 7,93 \cdot 10^{-3} + 4,13 \cdot 10^{-3} (L_{p,d}/B) - 0,125 (d_{tow}/L_{p,d}); \quad (3.16.4.7.1-3)$$

where: d_{tow} – dock draught amidships during voyage in tow, in m;

h_d – design wave height, in m, determined depending on the length of the dock:

$$h_p = 10,9 - \left(\frac{300 - L_{p,d}}{100} \right)^2 \quad \text{for } L_{p,d} < 300 \text{ m}; \quad (3.16.4.7.1-4)$$

$H_d = 10,9$ for $L_{p,d} \geq 300$ m;

σ_{perm} – permissible normal stresses in longitudinal bending of the dock, in MPa, taken equal to:

150 – for docks under 100 m in length;

$150 + 0,75(L_{p,d} - 100)$ – for docks between 100 and 200 m in length;

225 – for docks over 200 m in length.

3.16.4.7.2 The still water bending moment M , in kN·m, in the midship section of the dock during the voyage in tow shall be reduced to the minimum possible level by suitable ballasting.

3.16.4.7.3 Sea state considered permissible for voyage in tow is that corresponding to a wave height of 3 per cent probability of exceeding level $h_{3\%}$, in m, determined by the formula:

$$h_{3\%} = h_{3\%}^0 + m(\lambda_1^2 / \lambda_2^2 - 1), \quad (3.16.4.7.3-1)$$

де: $h_{3\%}^0$ – rated wave height, in m, permissible for voyage of a floating dock, with a relationship $L_{p,d}/B = 4,25$, determined by the formulae:

$$h_{3\%}^0 = 0,313 + 0,0438 L_{p,d}, \quad \text{for } L_{p,d} < 130 \text{ m};$$

$$h_{3\%}^0 = 3,10 + 0, L_{p,d}, \quad \text{for } 130 \text{ m} \leq L_{p,d} \leq 260 \text{ m}; \quad (3.16.4.7.3-2)$$

$$h_{3\%}^0 = 0,422 + 0, L_{p,d}, \quad \text{for } L_{p,d} > 260 \text{ m};$$

m – factor determined by the formulae:

$$m = 0,483 + 0,0218 L_{p,d}, \quad \text{for } L_{p,d} < 130 \text{ m};$$

$$m = 2,42 + 0,00685 L_{p,d}, \quad \text{for } 130 \text{ m} \leq L_{p,d} \leq 260 \text{ m}; \quad (3.16.4.7.3-3)$$

$$m = 0,356 + 0,0148 L_{p,d}, \quad \text{for } L_{p,d} > 260 \text{ m};$$

factors λ_1 and λ_2 are determined by the formulae:

$$\lambda_1 = M/M^0;$$

$$\lambda_2 = 1,276 - 0,065(L_{cn}/B); \quad (3.16.4.7.3-4)$$

where: M^0 – basic bending moment, in kNm, determined by the formula:

$$M^0 = 0,77 \cdot 10^{-2} L_{p,d}^{3,65} / \eta; \quad (3.16.4.7.3-5)$$

where for η – refer to **1.1.4.3**,

M – bending moment, in kNm, corresponding to the actual section modulus of the floating dock hull, determined by the formula:

$$M = k_\sigma \sigma_n W \cdot 10^{-3}; \quad (3.16.4.7.3-6)$$

W – actual minimum section modulus of the dock hull to the moment of voyage;

$k_\sigma = 0,8$ – is a factor of permissible normal stresses;

σ_n – as defined in **1.1.4.3**.

3.16.4.7.4 Correspondence between permissible sea state during voyage and waves heights of 3 % probability of exceeding level shall be determined according to Table 3.16.4.7.4.

Table 3.16.4.7.4

Permissible sea state	$h_{3\%}$
5	2,0 ÷ 3,5
6	3,5 ÷ 6,0
7	6,0 ÷ 8,5
8	8,5 ÷ 11,0

9

11,0

3.16.4.7.5 A possibility of voyage of a dock in tow whose architecture and relationships of the dimensions differ from those referred to in **3.16.1.1** shall be supported using the procedure agreed with the Register..

3.16.4.7.6 Voyage of a dock in tow within the limits of one and the same sea is permitted when the environmental conditions (sea state) corresponding to the requirements of **3.16.4.7.3** ÷ **3.16.4.7.5** are expected.

3.17 TUGS – PUSHERS, PUSHED BARGES

3.17.1 The requirements of this paragraph apply to tugs - pushers, pushed barges of all purposes of mixed "sea - river" navigation with sign **R3-RS** in the ship's class notation.

3.17.2 In addition to the requirements of **3.9** and Sections **1** and **2**, the hull structure of the tugs - pushers and pushed barges shall comply with additional requirements of Directive (EU) 2016/1629 (ES-TRIN).

APPENDIX 1

TESTING PROCEDURES OF WATERTIGHT COMPARTMENTS.

Part A _ Ships Covered by SOLAS (SOLAS Ships)

1. GENERAL

1.1 These test procedures shall confirm the watertightness of tanks and watertight boundaries and the structural adequacy of tanks which consist of the watertight subdivisions¹ of ships. These procedures may also be applied to verify the weathertightness of structures and shipboard outfitting. The tightness of all tanks and watertight boundaries of ships during new construction and those relevant to major conversions or major repairs² shall be confirmed by these test procedures prior to the delivery of the ship.

1.2 Testing procedures of watertight compartments for SOLAS ships (including bulk carriers and oil tankers covered by the requirements of IACS Common Structural Rules for Bulk Carriers and Oil Tankers (hereinafter – oil tankers and bulk carriers, built on the IMO targeted standards)), shall be carried out in accordance with Part A of this Appendix, unless:

- a) the shipyard provides documentary evidence of the shipowner's agreement to a request to the Administration for an exemption from the application of SOLAS Chapter **II-1**, regulation **11**, or for an equivalency agreeing that the content of Part B is equivalent to SOLAS Chapter **II-1**, regulation **11**; and
- b) the above-mentioned exemption/equivalency has been granted by the responsible Administration.

¹ Watertight subdivision means the transverse and longitudinal subdivisions of the ship required to satisfy the subdivision requirements of SOLAS Chapter **II-1**.

² Major repair means a repair affecting structural integrity.

2. APPLICATION

All gravity tanks and other boundaries required to be watertight or weathertight shall be tested in accordance with this Appendix and proven to be tight and structurally adequate as follows:

- gravity tanks for their tightness and structural adequacy;
- watertight boundaries other than tank boundaries for their watertightness; and
- weathertight boundaries for their weathertightness.

The testing of cargo containment systems of liquefied gas carriers shall be in accordance with the testing requirements in **4.21 - 4.26** of the International Code for the Construction and Equipment of Ships Carrying Liquefied Gases in Bulk (IGC Code) and standards deemed appropriate by the Register.

Tests of structures not listed in Table 4.1-1 or Table 4.1-2 should be considered separately.

Note.

Gravity tank means a tank that is subject to vapour pressure not greater than 70 kPa.

3. TEST TYPES AND DEFINITIONS

3.1 The following two types of tests are specified in this Appendix:

Structural test is a test to verify the structural adequacy of tank construction. This may be a hydrostatic test or, where the situation warrants, a hydropneumatic test;

Leak test is a test to verify the tightness of a boundary.

Unless a specific test is indicated, this may be a hydrostatic/hydropneumatic test or an air test. A hose test may be considered an acceptable form of leak test for certain boundaries, as indicated by Footnote 9 of Table 4.1-1.

3.2 Definition of each type of test is given in Table 3.2.

Table 3.2

Test types	Test procedures
------------	-----------------

Hydrostatic test: (Leak and structural)	A test wherein a space is filled with a liquid to a specified head.
Hydropneumatic test: (Leak and structural)	A test combining a hydrostatic test and an air test, wherein a space is partially filled with a liquid and pressurized with air.
Hose test: (Leak)	A test to verify the tightness of a joint by a jet of water with the joint visible from the opposite side.
Air tests: (Leak)	A test to verify tightness by means of air pressure differential and leak indicating solution. It includes tank air test and joint air tests, such as compressed air fillet weld tests and vacuum box tests.
Compressed air fillet weld test: (Leak)	An air test of fillet welded tee joints wherein leak indicating solution is applied on fillet welds.
Vacuum box test: (Leak)	A box over a joint with leak indicating solution applied on the welds. A vacuum is created inside the box to detect any leaks.
Ultrasonic test: (Leak)	A test to verify the tightness of the sealing of closing devices such as hatch covers by means of ultrasonic detection techniques.
Penetration test: (Leak)	A test to verify that no visual dye penetrant indications of potential continuous leakages exist in the boundaries of a compartment by means of low surface tension liquids (i.e. dye penetrant test).

4. TEST PROCEDURES

4.1 General.

Tests shall be carried out in the presence of the Register surveyor at a stage sufficiently close to the completion of work with all hatches, doors, windows, etc., installed and all penetrations including pipe connections fitted, and before any ceiling and cement work is applied over the joints.

Specific test requirements are given in 4.4, Tables 4.1-1 and 4.1-2.

For the timing of the application of coating and the provision of safe access to joints, refer to 4.5, 4.6 and Table 4.1-3.

Table 4.1-1 Test requirements for tanks and boundaries

Nos.	Tank or boundary to be tested	Test type	Test head or pressure	Remarks
1	2	3	4	5
1	Double bottom tanks ¹	Leak and structural ²	The greater of: top of the overflow; or to 2,4 m above top of tank ³ ; or to bulkhead deck	
2	Double bottom voids ⁴	Leak	Refer to 4.4.4 through 4.4.6, as applicable	Including pump room double bottom and bunker tank protection double hull required by MARPOL Annex I
3	Double side tanks	Leak and structural ²	The greater of:	

			top of the overflow, to 2,4 m above top of tank ³ ; or to bulkhead deck	
4	Double side voids	Leak	Refer to 4.4.4 through 4.4.6, as applicable	
5	Deep tanks other than those listed elsewhere in this table	Leak and structural ²	The greater of: top of the overflow; or to 2,4 m above top of tank ³	
6	Cargo oil tanks	Leak and structural ²	The greater of: top of the overflow; or to 2,4 m above top of tank ³ ; or to top of tank ³ plus setting of any pressure relief valve	
7	Ballast hold of bulk carriers	Leak and structural ²	Top of cargo hatch coaming	
8	Peak tanks	Leak and structural ²	The greater of: top of the overflow; or to 2,4 m above top of tank ³	After peak to be tested after installation of stern tube
9	.1 Fore peak spaces with equipment	Leak	Refer to 4.4.4 through 4.4.6, as applicable	
	.2 Fore peak voids	Leak	Refer to 4.4.4 through 4.4.6, as applicable	
	.3 Aft peak spaces with equipment	Leak	Refer to 4.4.3 through 4.4.6, as applicable	
Nos.	Tank or boundary to be tested	Test type	Test head or pressure	Remarks
1	2	3	4	5
9	.4 Aft peak voids	Leak	Refer to 4.4.3 through 4.4.6, as applicable	After peak to be tested after installation of stern tube
10	Cofferdams	Leak	Refer to 4.4.3 through 4.4.6, as applicable	
11	.1 Watertight bulkheads	Leak ⁶	Refer to 4.4.3 through 4.4.6, as applicable	
	.2 Superstructure end bulkheads	Leak	Refer to 4.4.3 through 4.4.6, as applicable	
12	Watertight doors below freeboard or bulkhead deck	Leak ^{7,8}	Refer to 4.4.3 through 4.4.6, as applicable	
13	Double plate rudder blades	Leak	Refer to 4.4.4 through 4.4.6, as applicable	
14	Shaft tunnels clear of deep tanks	Leak ⁹	Refer to 4.4.3 through 4.4.6, as applicable	
15	Shell doors	Leak ⁹	Refer to 4.4.3 through 4.4.6, as applicable	

16	Weather-tight hatch covers and closing appliances	Leak ^{7,9}	Refer to 4.4.3 through 4.4.6, as applicable	Hatch covers closed by tarpaulins and battens excluded
17	Dual purpose tanks/dry cargo hatch covers	Leak ^{7,9}	Refer to 4.4.3 through 4.4.6, as applicable	In addition to structural test in item 6 or 7
18	Chain lockers	Leak and structural ²	Top of chain pipe	
19	Lubricating oil sump tanks and other similar tanks/spaces under main engines	Leak ⁵	Refer to 4.4.3 through 4.4.6, as applicable	
20	Ballast ducts	Leak and structural ²	The greater of: ballast pump maximum pressure; or setting of any pressure relief valve	
21	Fuel oil tanks	Leak and structural ²	The greater of: top of the overflow; or to 2,4 m above top of tank ³ ; or to top of tank ³ plus setting of any pressure relief valves; or to bulkhead deck	
22	Sea chests and ice boxes	Leak and structural ^{1,2}	The greater of: head to 1,25 m depthwise; or equal to blow system pressure	When testing ice boxes fitted with steam heating system, the test head shall in any case be below the heating system design pressure. Where air pipes are led through ice boxes and sea chests, the tests are carried out by applying the hydraulic head to top of the overflow

¹ Including tanks arranged in accordance with the provisions of SOLAS regulation II-1/9.4.

² Refer to 4.2.2.

³ The top of a tank is the deck forming the top of the tank, excluding any hatchways.

⁴ Including duct keels and dry compartments arranged in accordance with the provisions of SOLAS regulation II-1/11.2 and II-1/9.4 respectively, and/or oil fuel tank protection and pump room bottom protection arranged in accordance with the provisions of MARPOL Annex I, Chapter 3, Part A regulation 12 and Chapter 4, Part A, regulation 22 respectively.

⁵ Where lubricating oil sump tanks and other similar spaces under main engines intended to hold liquid form part of the watertight subdivision of the ship, they shall be tested as per the requirements of item 5 "Deep tanks other than those listed elsewhere in this table".

⁶ A "Leak and structural test", refer to 4.2.2 shall be carried out for a representative cargo hold if intended for in-port ballasting. The filling level requirement for testing cargo holds intended for in-port ballasting shall be the maximum loading that will occur in-port as indicated in the Loading Manual.

⁷ As an alternative to the hose testing, other testing methods listed in 4.4.7 through 4.4.9 may be applicable subject to adequacy of such testing methods being verified. Refer to SOLAS regulation II-1/11.1. For watertight bulkheads (refer to 11.1) alternatives to the hose testing may only be used where a hose test is not practicable.

⁸ Where water tightness of a watertight door has not been confirmed by prototype test, testing by filling watertight spaces with water shall be carried out. Refer to SOLAS regulation II-1/16.2.

⁹ Hose test may also be considered as a medium of the test. Refer to 3.2.

Table 4.1-2 Additional test requirements for special service ships/tanks

Nos.	Type of ship/tank	Structures to be tested	Type of tes	Test head or pressure	Remarks
1	2	3	4	5	6

1	Liquefied gas carriers ³	Integral tanks	Leak and structural	Refer to IACS UR G1	
		Hull structure supporting membrane or semi membrane tanks	Refer to IACS UR G1	Refer to IACS UR G1	
		Independent tanks type A	Refer to IACS UR G1	Refer to IACS UR G1	
		Independent tanks type B	Refer to IACS UR G1	Refer to IACS UR G1	
		Independent tanks type C	Refer to IACS UR G2	Refer to IACS UR G2	
2	Edible liquid tanks	Independent tanks	Leak and structural ¹	The greater of: top of the overflow; or to 0,9 m above top of tank ²	
3	Chemical tankers ⁴	Integral or independent cargo tanks	Leak and structural ¹	The greater of: to 2.4 m above top of tank ² ; or to top of tank ² plus setting of any pressure relief valve	Where a cargo tanks is designed for the carriage of cargoes with specific gravities larger than 1,0 ³ , an appropriate additional head shall be considered
¹ Refer to 4.2.2. ² Top of tank is deck forming the top of the tank excluding any hatchways. ³ Type of cargo tanks in accordance with The International Code for Construction and Equipment of Ships Carrying Liquefied Gases in Bulk (<i>IGC Code</i>). ⁴ Type of cargo tanks in accordance with The International Code for the Construction and Equipment of Ships Carrying Dangerous Chemicals in Bulk (<i>IBC Code</i>).					

Table 4.1-3 Application of leak test, coating and provision of safe access for type of welded joints

Type of welded joints		Leak test	Coating ¹		Safe access ²	
			Before leak test	After leak test but before structural test	Leak test	Structural test
1	2	3	4	5	6	7
Butt	Automatic	Not required	Allowed ³	Не застосовується	Not required	Not required
	Manual or semiautomatic ⁴	Required	Not allowed	Allowed	Required	Not required
Fillet	Boundary including penetrations	Required	Not allowed	Allowed	Required	Not required
¹ Coating refers to internal (tank/hold coating), where applied, and external (shell/deck) painting. It does not refer to shop primer. ² Temporary means of access for verification of the leak test. ³ The condition applies provided that the welds have been carefully inspected visually to the satisfaction of the Register surveyor.						

⁴ Flux core arc welding (FCAW) semiautomatic butt welds need not be tested provided that careful visual inspections show continuous uniform weld profile shape, free from repairs, and the results of NDT show no significant defects.

4.2 Structural test procedures.

4.2.1 Type and time of test.

Where a structural test is specified in Table 4.1-1 or 4.1-2, a hydrostatic test in accordance with **4.4.1** will be acceptable. Where practical limitations (strength of building berth, light density of liquid, etc.) prevent the performance of a hydrostatic test, a hydropneumatic test in accordance with **4.4.2** may be accepted instead.

A hydrostatic test or hydropneumatic test for the confirmation of structural adequacy may be carried out while the ship is afloat, provided the results of a leak test are confirmed to be satisfactory before the ship is afloat.

4.2.2 Testing schedule for new construction or major structural conversion.

4.2.2.1 Tanks which are intended to hold liquids, and which form part of the watertight subdivision of the ship¹, shall be tested for tightness and structural strength as indicated in Table 4.1-1 and 4.1-2.

4.2.2.2 The tank boundaries shall be tested from at least one side. The tanks for structural test shall be selected so that all representative structural members are tested for the expected tension and compression.

4.2.2.3 The watertight boundaries of spaces other than tanks for structural testing may be exempted, provided that the watertightness of boundaries of exempted spaces is verified by leak tests and inspections. Structural testing may not be exempt and the requirements for structural testing of tanks in 4.2.2.1 _ 4.2.2.2 shall apply, for ballast holds, chain lockers and a representative cargo hold if intended for in-port ballasting.

4.2.2.4 Tanks which do not form part of the watertight subdivision of the ship¹, may be exempted from structural testing provided that the watertightness of boundaries of exempted spaces is verified by leak tests and inspections.

¹ Watertight subdivision means the transverse and longitudinal subdivisions of the ship required to satisfy the subdivision requirements of SOLAS Chapter II-1.

4.3 Leak test procedures.

For the leak tests specified in Table 4.1-1, tank air tests, compressed air fillet weld tests, vacuum box tests in accordance with **4.4.4** through **4.4.6**, or their combination, will be acceptable. Hydrostatic or hydropneumatic tests may also be accepted as leak tests provided that **4.5**, **4.6** and **4.7** are complied with. Hose tests will also be acceptable for such locations as specified in Table 4.1-1, Footnote ⁹, in accordance with **4.4.3**.

The application of the leak test for each type of welded joint is specified in Table 4.1-3.

Air tests of joints may be carried out in the block stage provided that all work on the block that may affect the tightness of a joint is completed before the test. Refer also to **4.5.1** for the application of final coatings and **4.6** for the safe access to joints and the summary in Table 4.1-3.

4.4 Tests methods.

4.4.1 Hydrostatic test.

Unless another liquid is approved, hydrostatic tests shall consist of filling the space with fresh water or sea water, whichever is appropriate for testing, to the level specified in Table 4.1-1 or 4.1-2. Refer also to 4.7.

In cases where a tank is designed for cargo densities greater than sea water and testing is with fresh water or sea water, the testing pressure height shall simulate the actual loading for those greater cargo densities as far as practicable.

All external surfaces of the tested space shall be examined for structural distortion, bulging and buckling, other related damage and leaks.

4.4.2 Hydropneumatic test.

Hydropneumatic tests, where approved, shall be such that the test condition, in conjunction with the approved liquid level and supplemental air pressure, will simulate the actual loading as far as practicable.

The requirements and recommendations for tank air tests in **4.4.4** will also apply to hydropneumatic tests. Refer also to **4.7**.

All external surfaces of the tested space shall be examined for structural distortion, bulging and buckling, other related damage and leaks.

4.4.3 Hose test.

Hose tests shall be carried out with the pressure in the hose nozzle maintained at least at $2 \cdot 10^5$ Pa during the test. The nozzle shall have a minimum inside diameter of 12 mm and be at a perpendicular distance from the joint not exceeding 1,5 m. The water jet shall impinge directly upon the weld.

Where a hose test is not practical because of possible damage to machinery, electrical equipment insulation or outfitting items, it may be replaced by a careful visual examination of welded connections, supported where necessary by means such as a dye penetrant test or ultrasonic leak test or the equivalent.

4.4.4 Tank air tes.

All boundary welds, erection joints and penetrations, including pipe connections, shall be examined in accordance with the approved procedure and under a stabilized pressure differential above atmospheric pressure not less than $0,15 \cdot 10^5$ Pa, with a leak indicating solution such as soapy water/detergent or a proprietary brand applied.

A U-tube with a height sufficient to hold a head of water corresponding to the required test pressure shall be arranged. The cross sectional area of the U-tube shall not be less than that of the pipe supplying air to the tank. Instead of using a U-tube, two calibrated pressure gauges may be acceptable to verify required test pressure. Arrangements involving the use of two calibrated pressure gauges to verify the required test pressure may be accepted taking into account the provisions in **F5.1** and **F7.4** of IACS recommendation No. 140 "Recommendation for Safe Precautions during Survey and Testing of Pressurized Systems".

A double inspection shall be made of tested welds. The first is to be immediately upon applying the leak indication solution; the second shall be after approximately four or five minutes in order to detect those smaller leaks which may take time to appear.

4.4.5 Compressed air fillet weld test.

In this air test, compressed air is injected from one end of a fillet welded joint and the pressure verified at the other end of the joint by a pressure gauge. Pressure gauges shall be arranged so that an air pressure of at least $0,15 \cdot 10^5$ Pa can be verified at each end of all passages within the portion being tested.

Note.

Where a leak test is required for fabrication involving partial penetration welds, a compressed air test shall also be applied in the same manner as to fillet weld where the root face is large, i.e. 6 - 8 mm.

4.4.6 Vacuum box test.

A box (vacuum testing box) with air connections, gauges and an inspection window is placed over the joint with a leak indicating solution applied to the weld cap vicinity. The air within the box is removed by an ejector to create a vacuum of $0,20 \cdot 10^5$ - $0,26 \cdot 10^5$ Pa inside the box.

4.4.7 Ultrasonic test.

An ultrasonic echoes transmitter shall be arranged inside of a compartment and a receiver shall be arranged on the outside. The watertight/weathertight boundaries of the compartment are scanned with the receiver in order to detect an ultrasonic leak indication. A location where sound is detectable by the receiver indicates a leakage in the sealing of the compartment.

4.4.8 Penetration test.

A test of butt welds or other weld joints uses the application of a low surface tension liquid at one side of a compartment boundary or structural arrangement.

If no liquid is detected on the opposite sides of the boundaries after expiration of a definite period of time, this indicates tightness of the boundaries. In certain cases, a developer solution may be painted or sprayed on the other side of the weld to aid leak detection.

4.4.9 Other tests.

Other methods of testing may be considered by the Register upon submission of full particulars prior to the commencement of testing.

4.5 Application of coating.

4.5.1 Final coating.

For butt joints welded by an automatic process, the final coating may be applied any time before the completion of a leak test of spaces bounded by the joints, provided that the welds have been carefully inspected visually to the satisfaction of the Register surveyor. For all other joints, the final coating shall be applied after the completion of the leak test of the joint. Refer also to Table 4.1-3.

The Register surveyors reserve the right to require a leak test prior to the application of the final coating over automatic erection butt welds.

4.5.2 Temporary coating.

Any temporary coating which may conceal defects or leaks shall be applied at the time as specified for the final coating (refer to **4.5.1**).

This requirement does not apply to shop primer.

4.6 Safe access to joints.

For leak tests, safe access to all joints under examination shall be provided. Refer also to Table 4.1-3.

4.7 Hydrostatic or hydropneumatic tightness test.

In cases where the hydrostatic or hydropneumatic tests are applied instead of a specific leak test, examined boundaries shall be dew-free, otherwise small leaks are not visible.

Part B – Ships Not Covered by SOLAS (Non-SOLAS Ships) and Ships Granted SOLAS Exemption/Equivalent (SOLAS Exemption/Equivalent Ships)**1. GENERAL**

1.1 These test procedures shall confirm the watertightness of tanks and watertight boundaries and the structural adequacy of tanks which consist of the watertight subdivisions¹ of ships. These procedures may also be applied to verify the weathertightness of structures and shipboard outfitting. The tightness of all tanks and watertight boundaries of ships during new construction and those relevant to major conversions or major repairs² shall be confirmed by these test procedures prior to the delivery of the ship.

¹ Watertight subdivision means the transverse and longitudinal subdivisions of the ship required to satisfy the subdivision requirements of SOLAS Chapter II-1, 1.2.

² Major repair means a repair affecting structural integrity.

1.2 Testing procedures of watertight compartments shall be carried out in accordance with Part B of this Appendix for non-SOLAS ships and those SOLAS ships (including CSR BC and OT) for which :

- a) the shipyard provides documentary evidence of the shipowner's agreement to a request to the Administration for an exemption from the application of SOLAS Chapter II-1, regulation 11, or for an equivalency agreeing that the content of Part B is equivalent to SOLAS Chapter II-1, regulation 11; and
- b) the above-mentioned exemption/equivalency has been granted by the responsible Administration.

2 APPLICATION

2.1 Testing procedures shall be carried out in accordance with the requirements of Part A of this Appendix in association with the alternative procedures for 4.2.2 and alternative test requirements for Table 4.1-1, Part A.

2.2 The tank boundaries shall be tested from at least one side. The tanks for structural test shall be selected so that all representative structural members are tested for the expected tension and compression.

2.3 Structural tests shall be carried out for at least one tank of a group of tanks having structural similarity (i.e. same design conditions, alike structural configurations with only minor localised differences determined to be acceptable by the attending Register surveyor) on each ship provided all other tanks are tested for leaks by an air test. The acceptance of leak testing using an air test instead of a structural test does not apply to cargo space boundaries adjacent to other compartments in tankers and combination carriers or to the boundaries of tanks for segregated cargoes or pollutant cargoes in other types of ships.

2.4 Additional tanks may require structural testing if found necessary after the structural testing of the first tank.

2.5 Where the structural adequacy of the tanks of a vessel were verified by the structural testing required in Table 4.1-1 of Part A of this Appendix, subsequent ships in the series (i.e. sister ships built from the same plans at the same shipyard) may be exempted from structural testing of tanks, provided that:

- .1 watertightness of boundaries of all tanks is verified by leak tests and thorough inspections are carried out;
- .2 structural testing is carried out for at least one tank of each type among all tanks of each sister ship;
- .3 additional tanks may require structural testing if found necessary after the structural testing of the first tank or if deemed necessary by the attending Register surveyor.

For cargo space boundaries adjacent to other compartments in tankers and combination carriers or boundaries of tanks for segregated cargoes or pollutant cargoes in other types of ships, the provisions of 2.5.2 of Part B of this Appendix shall apply in lieu of 2.3 of Part B.

2.6 Sister ships built (i.e. keel laid) two years or more after the delivery of the last ship of the series, may be tested in accordance with 2.5 of Part B of this Appendix, provided that:

- .1 general workmanship has been maintained (i.e. there has been no discontinuity of shipbuilding or

significant changes in the construction methodology or technology at the yard, shipyard personnel are appropriately qualified and demonstrate an adequate level of workmanship as determined by the Register); and

.2 an NDT plan is implemented and evaluated by the Register for the tanks not subject to structural tests. Shipbuilding quality standards for the hull structure during new construction shall be reviewed and agreed during the kick-off meeting. Structural fabrication shall be carried out in accordance with IACS recommendation 47 "Shipbuilding and Repair Quality Standard", or a recognised fabrication standard which has been accepted by the Register prior to the commencement of fabrication/construction.

The work shall be carried out in accordance with the VRS rules and under the VRS technical supervision.

REQUIREMENTS TO SHIP LOADING INSTRUMENTS

1. GENERAL

1.1 The present Requirements shall be applied together with those of Part II "Hull" of these Rules when approving the loading instruments of ships whose instruments are not yet approved.

1.2 The Requirements apply to loading instruments representing a computer-based system consisting of software for ship load calculation and of hardware for its realization. Requirements pertinent to the program and its functional capabilities shall be found in **3.1** and Section **4** of this Appendix respectively. Requirements pertinent to type approval for hardware shall be found in **1.8** and **3.2** of this Appendix.

1.3 A loading instrument shall not substitute for an approved Loading Manual.

1.4 The loading instrument belongs to special equipment carried onboard, and the calculation results obtained by using it apply only to the ship for which it was approved.

1.5 Ships undergoing major modifications or modernization, such as lengthening or deck removal affecting the longitudinal strength of hull, shall be considered new ships for the purpose of the Requirement.

1.6 For each ship, the loading instrument approval procedure shall include the following:

basic data verification and loading conditions approval with issuing of a Report for subsequent testing of the program;

hardware approval with issuing of a Certificate, where necessary;

handover tests with a subsequent issuing of a Report.

1.7 The program for the loading instrument shall be type-approved by the Register which shall be confirmed by issuing a Type Approval Certificate for Computer Program. In such cases, certain stages may be omitted in the basic data verification procedure for a particular ship (refer to **2.1.7**).

1.8 Hardware shall be approved, if there is a single computer for which a Type Approval Certificate, was issued in accordance with the requirements of **3.2** of this Appendix, or there are two computers specially installed for the case one of them fails. If there are two computers, no type approval is necessary for them but in this case, each computer shall pass handover tests. Besides, computers being a part of the shipboard net shall be approved by the Register which shall be confirmed by issuing a Certificate in accordance with the relevant requirements of these Rules.

1.9 A Report shall be issued for the program on the basis of the satisfactory results of handover tests of the loading instrument carried out onboard the ship in accordance with the requirements of **2.3** of this Appendix.

2. APPROVAL PROCEDURE

2.1 Basic data verification and approval. Loading conditions approval for program testing.

2.1.1 Calculation results and the actual ship data used for the program shall be verified onboard the ship for which the program is intended.

2.1.2 On receipt of an application for data verification, the Register shall offer to the applicant four loading conditions as a minimum, borrowed from an approved Loading Manual and to be used for program testing. These loading conditions shall ensure the loading of each ship compartment for one time at least. These loading conditions shall generally cover the whole range of possible ship draughts from the greatest one in the loaded condition to the smallest one in the ballasted condition.

2.1.3 Control points shall generally be positioned on transverse bulkheads or other obvious compartment boundaries. Additional control points may be necessary between the bulkheads of long holds or tanks, or between container stacks.

2.1.4 If the torque on calm water shall be determined, the software shall demonstrate it on a single test loading condition of the ship.

2.1.5 It is important that the basic data included in the program are in agreement with those contained in the approved Loading Manual. Special attention shall be paid to the final mass value of the ship in the light condition and the position of its gravity centre adopted on the basis of inclining test or proceeding from the results of the light ship condition verification.]

2.1.6 The following basic data shall be submitted to the Register by the applicant in order to verify whether they are in agreement with the ship constructed:

principal dimensions, coefficients of fineness of the lines and, where necessary, the lateral projection of the ship;

position of forward and aft perpendiculars and, where necessary, the procedure for determining the forward and stern draughts at actual draught mark locations;

light ship displacement and its distribution through the ship length;

lines drawing and/or tables of offsets, or Bonjean scales including 21st section on the length between perpendiculars;

compartments description including spacing, volume centres and volume tables (tank capacity tables/ tables showing the mass of liquid in a tank filled to different levels) where necessary;

deadweight composition for each loading condition.

Identification details of the program including the version number shall be verified also.

2.1.7 The basic data verification procedure may be considered to be completed, if:

the requirements of **3.1** of this Appendix are fulfilled in respect of the program;

the purpose of the program is clearly formulated and the calculation methods with the algorithm are in accordance with the requirements of these Rules;

the requirements of Section **4** of this Appendix are fulfilled with regard to the functional capabilities of the program;

the precision of calculations made on the basis of the program is within the tolerances stipulated by **2.5** of this Appendix;

ship particulars are in accordance with the requirements of **2.1.5** of this Appendix;

the Program User's Manual is clear and brief and complies with the requirements of **2.4** of this Appendix and is checked and duly noted by the Register;

data are given concerning the minimal requirements for hardware; ship loading conditions intended for the program testing are approved which is confirmed by the Report.

2.1.8 Type Approval Certificate for Computer Program shall be issued on the basis of the requirements of **2.2** of this Appendix. Where the program is type approved, the basic data verification procedure may be considered to be completed, if:

it is found that the type-approved program is applicable to the ship in question;

information contained in the valid Certificate, is in compliance with the program being identified and its version number;

the precision of calculations made on the basis of the program is within the tolerances stipulated in **2.5** of this Appendix; ship particulars are in accordance with the requirements of **2.1.5** of this Appendix;

the Program User's Manual is clear and brief and complies with the requirements of **2.4** of this Appendix and is checked and duly noted by the Register;

data are given concerning the minimal requirements for hardware;

ship loading conditions intended for the program testing are approved and there is a Report on the program operation testing.

2.1.9 Approved loading conditions given in the Loading Manual and the Report are sent to the surveyors by the Head Office noting the necessity of handover tests to be held. Where the ship is in service, the approved loading conditions and the Report are sent to the shipowner who shall ensure that they are delivered onboard and that handover tests are held with the VRS surveyor participating.

2.2 Type approval.

2.2.1 A program for the loading instrument may be type approved according to the requirements of this Chapter. If the tests are completed satisfactorily, Type Approval Certificate for Computer Program shall be issued for the program.

2.2.2 The Certificate shall be valid for an identified version of the program only.

2.2.3 After the application for the type approval of a program has been submitted, the Register will provide the applicant with data for its testing for two ship types at least. Where programs using basic data on hull shape are concerned, the program test data shall be provided for three ship types. These data shall be used by the applicant for running the program in respect of the tested ships. The results (including the data-of-the-lines-plan curve and the interpolation curve output, if applicable) obtained by using the program shall be submitted to the Register in order the precision of calculations might be assessed. The Register shall make parallel calculations using the same basic data and compare their results with those obtained by means of the program submitted.

2.2.4 The Certificate may be issued if:

the requirements of **3.1** of this Appendix are fulfilled in respect of the program;
the purpose of the program is clearly formulated and the calculation methods with the algorithm are in accordance with the requirements of these Rules;

the requirements of Section **4** of this Appendix are fulfilled with regard to the functional capabilities of the program;

the precision of calculations made on the basis of the program is within the tolerances stipulated in **2.5** of this Appendix;

the Program User's Manual is clear and brief, and is submitted to the Register for review; data are given concerning the minimal requirements for hardware.

2.2.5 The Certificate shall include a detailed description of calculations for which the program is approved and of limitations imposed upon the program.

2.2.6 The Certificate shall be issued for a maximum period of 5 years. The Certificate may be extended after the developer has confirmed that the algorithm is unchanged in the program.

2.2.7 A valid Certificate will be invalidated, if the algorithm is changed in the program by the developer without prior agreement with the Register. In such a case, the revised program shall be considered a new one.

2.3 Handover tests.

2.3.1 Handover tests shall be held soon after the loading instrument installation aboard the ship.

2.3.2 During handover tests, the user, one of the senior officers shall use the instrument for calculating a test loading condition of the ship. The operation shall be confirmed by the surveyor. Data obtained by means of the instrument shall agree with those stated for the approved test loading conditions. Where the numerical output data given by the instrument do not agree with those stated in the approved test loading conditions, the Report shall not be issued.

2.3.3 Handover tests shall also be carried out in respect of the second computer specially installed to be used if the first one fails. Data obtained by means of the loading instrument shall agree with those stated for the approved tests loading conditions. Where the output numerical data of the loading instrument do not agree with those stipulated for the approved tests loading conditions, no Report shall be issued. If handover tests are effected using a computer for which the Type Approval Certificate was issued, the second specially installed computer need not be tested.

2.3.4 Where hardware is not approved, it shall be demonstrated that handover tests results for the program are satisfactory for both the first and the second specially installed computer, subsequent to which the Report on the program handover tests may be issued.

2.3.5 After satisfactory completion of handover tests, the VRS surveyor shall attach the approved test loading conditions for the ship, as well as the Program Test Report to the Program User's Manual formerly duly noted by the Register. Then, the Report (Form 1.9.18) on handover tests of the program will be issued by the Register.

2.4 Program User's Manual.

2.4.1 The Manual shall be submitted to the Register for review. In case of satisfactory results of the consideration, the Manual shall be duly noted by the Register.

2.4.2 The Manual shall be drawn up in a brief and clear way and shall be provided preferably with drawings and block diagrams.

2.4.3 The Manual shall include the following information:

general description of the program with indication of its version identification number;

a copy of Type Approval Certificate for Computer Program;

data on minimal required hardware properties necessary for program operation;

description of error messages and warning reports that can be issued by computer and clear instructions concerning the user's subsequent steps in this case;

light ship displacement and gravity centre of the ship coordinates;

full deadweight composition for each test loading condition of the ship;

values of permissible shearing forces and bending moments in calm water given or taken into consideration by the Register;

values of permissible cargo torque, where applicable;

correction factors for shearing forces, where applicable;

local permissible limitations on the loading of particular holds and two adjacent holds proceeding from the maximum cargo mass for each hold in relation to the relevant ship draught, where applicable;

example of ship loading conditions determination with illustrations and computer data out;

example of each display screen data out with explanations.

2.5 Allowance for calculation accuracy.

The accuracy of calculations made using the program shall be within the range of acceptable allowances given in Table 2.5.

The accuracy of calculations can be determined by comparing, at each control point, the results of calculations made using the program to those obtained by using an independent program of the Register or an approved Loading Manual containing the similar basic data.

Table 2.5 Range of allowances for calculation accuracy

Design value	Allowance (percentage of permissible value)
Shearing force on still water N_{SW}	±5
Bending moment on still water M_{SW}	±5
Torque on still water M_{TSW}	±5

2.6 Hardware approval.

The hardware of a loading instrument shall be in accordance with the requirements of 1.8 and 3.2 of this Appendix if it is type-approved by the Register.

3. REQUIREMENTS TO THE SYSTEM

3.1 Program.

3.1.1 It is recommended that the development and release of the program shall be carried out in accordance with the relevant international quality standards (for instance, ISO 9001 or equivalent ДСТУ EN ISO 9001: 2018).

3.1.2 Software shall be developed so as to render it impossible for the user to modify data files of the ship containing the following information:

- lightweight displacement of the ship, lightweight ship mass distribution and the relevant gravity centres;
- structural restrictions imposed by the Register;
- data essential for hull geometry;
- hydrostatic data;

description of compartments including spacing, volume centres and volume tables (tank capacity tables/tables showing the volume of liquid in a tank when filled to different levels) where necessary.

3.1.3 Any changes to software that can influence longitudinal strength shall be introduced by the developer or his appointed representative, and the Register shall be immediately notified accordingly. The absence of a notification of any changes to the program may render the Certificate issued by the Register invalid. When the Certificate is found to be invalid by the Register, the modified program will be considered anew in accordance with the requirements of this Appendix.

3.2 Hardware of an independent computer.

3.2.1 Type Approval Certificate, and Hardware Approval Certificate shall be issued by the Register on condition the hardware is in accordance with the requirements contained in 3.2.2 of this Appendix, as well as with the requirements of these Rules and the Rules for Technical Supervision.

3.2.2 The developer shall submit the detailed information on the hardware shall be installed on board. The following information shall be submitted to the Register for review:

- hardware specification;
- the relevant design drawings with indicated materials, catalogues, data sheets, calculations and functional descriptions;
- test program suggested for demonstration, confirming that the operational requirements of the above standards can be fulfilled;
- certificates and the relevant test reports obtained for the product earlier.

3.2.3 When considering the documentation mentioned in 3.2.2, the Register may recognize the validity of certificates and reports issued by another certification body or accredited laboratory.

3.2.4 The operational and climatic tests shall be held in the presence of the Register representative under the standard test conditions so that a type approval could be issued in accordance with Part XV "Automation" of these Rules. The following inspections and tests shall be completed satisfactorily:

- external examination;
- functional tests;

disturbance in electric power supply;
 thermal resistance testing;
 moisture resistance testing;
 vibration tests;
 testing by oscillating and prolonged tilting motion conditions;
 testing of insulation electric strength, insulation resistance measurement;
 cold resistance tests;
 electromagnetic compatibility tests.

3.2.5 The Register shall be notified of any modifications to hardware specification.

4. REQUIREMENTS CONCERNING FUNCTIONAL CAPABILITIES

4.1 General.

4.1.1 The computational functions inherent in the program will depend on the requirements contained in these Rules and in the Rules for Technical Supervision.

4.1.2 2 The program shall be convenient for the user and be developed so as to minimize the possibility of incorrect initial data input by the user.

4.1.3 Calculations of the fore, midlength and after draughts at relevant perpendiculars shall be submitted in a form easily understandable for the user both in files and as hard copies.

4.1.4 For the case of the actual ship loadline positions of the, the fore, midlength and after draughts shall be determined and submitted in a form easily understandable for the user both in files and as hard copies. Provision shall be made for submitting the sagging/hogging data for the hull.

4.1.5 Displacement shall be determined for the particular loading condition of the ship and the corresponding value of the draught, and shall be submitted to the user both in file and as a hard copy.

4.1.6 The loading instrument shall issue printouts containing output data both in digital and graphic form. The output data in digital form shall be represented both in the absolute values and as percentage of permissible values. Printouts shall contain description of the relevant loading condition of the ship.

4.1.7 All the electronic and hard copy data shall be represented in a form easily understandable for the user with indication of the identification number of the program version.

4.2 Forces and moments originating in the hull.

4.2.1 The program shall ensure an analysis of the following forces and moments in the ship hull in accordance with the requirements of this Part of the Rules:

shearing force N_{sw} in still water, with a correction where applicable;
 bending moment M_{sw} in still water, with a correction where applicable;
 torque M_{tsw} in still water, where applicable.

In case of open ships, particular attention shall be paid to loads under which hull twisting occurs.

4.2.2 Data to be submitted to or duly noted by the Register are included in Table 4.2.2.

Table 4.2.2

Design value	Data to be submitted to or duly noted by the Register
shearing force N_{sw} in still water	1. Control points (frame numbers) for N_{sw} determination. Such points shall generally be chosen on transverse bulkheads or other obvious boundaries of compartments. Additional control points may be indicated between the bulkheads of long holds or tanks, as well as between container stacks. 2. Correction factors for shearing forces and their application procedure. 3. Permissible values [of N_{sw}], at sea and in port, for control points mentioned in item 1. Where necessary, an additional range of permissible values [of N_{sw}] can be specified.
bending moment M_{sw} in still water	1. Control points (frame numbers) for M_{sw} determination. Such points shall generally be chosen on transverse bulkheads, at hold centres or other obvious boundaries of compartments. 2. Permissible values [of M_{sw}], at sea and in port, for control points mentioned in item 1. Where necessary, an additional range of permissible values [of M_{sw}] can be specified.
Torque M_{tsw} on still water (where applicable)	1. Control points (frame numbers) for M_{tsw} determination. 2. Permissible values [of M_{tsw}] for control points mentioned in item 1.

4.2.3 Forces and moments shall be determined in absolute values and as percentage of permissible values, and shall be submitted both in graphical and tabulated form. The forces and moments determined, as well as their permissible values for each of the control points indicated, shall be submitted both in files and as hard copies. Any limitations concerning hull bending in the vertical direction in still water or hull twisting, for instance, may be considered on the basis of the requirements of the Rules.

4.3 Permissible loads, loading and capacity.

4.3.1 The program user shall be timely, clearly and unambiguously informed about the following restrictions imposed by the Register, concerning:

all permissible shearing forces and bending moments in still water;

permissible torques in still water, where applicable;

all local loading restrictions pertinent to both the loading of a particular hold and of the one adjacent thereto, where applicable;

mass of cargo contained in the hold;

ballast tanks and holds capacity;

restrictions on filling.

4.3.2 Violation of any of the restrictions imposed shall be easily detectable by the program user.

5. PERFORMANCE TEST

5.1 General.

When a loading instrument shall be installed on board and Report or a report on its previous testing by the Register is not available, the surveyor shall notify the VRS Head Office accordingly.

5.2 Extent of survey.

When a loading instrument is tested, the results obtained on the basis of the program shall be identical to those given in the approved test loading conditions of the ship. If the numerical output data obtained using the loading instrument do not agree with those to be found in the approved test loading conditions, the class assignment requirements shall be applied to the ship and the owner shall be notified accordingly. The program shall be tested on all the computers intended for it (those which are type approved or specially designed for the program).

EVALUATION OF SCANTLINGS OF CORRUGATED TRANSVERSE WATERTIGHT BULKHEADS IN NON-CSR BULK CARRIERS CONSIDERING HOLD FLOODING

1 APPLICATION AND DEFINITIONS¹

1.1 Application.

This procedure apply to bulk carriers specified in 3.3.4.10 of this Part.

1.2 Definitions.

Definitions and explanations relating to the general terminology of the Rules referred to in 1.1.3 of this part of the Rules.

The following definitions have been adopted in this Annex:

Homogeneous loading condition is a loading condition in which the ratio between the highest and the lowest filling ratio, evaluated for each hold, does not exceed 1,20, to be corrected for different cargo densities.

Net thickness t_{net} is the thickness obtained by applying the strength criteria given in Section 4 of this Appendix.

Required thickness is obtained by adding the corrosion addition t_s , given in Section 6 of this Appendix, to the net thickness t_{net} .

The main structural type of bulk carriers is determined in accordance with 3.3.1.4, Part II "Hull". The evaluation of scantling of corrugated transverse watertight bulkhead in non CSR bulk carriers considering hold flooding shall be determined in accordance with 3.3.4.10 of this part of the Rules.

2. LOAD MODEL

2.1 General.

Loads to be considered as acting on the bulkheads are those given by the combination of the cargo loads with those induced by the flooding of one hold adjacent to the bulkhead under examination. In any case, the pressure due to the flooding water alone shall be considered.

The most severe combinations of cargo induced loads and flooding loads are to be used for the check of the scantlings of each bulkhead, depending on the loading conditions included in the Loading Manual:

- homogeneous loading conditions;
- non homogeneous loading conditions;
- considering the individual flooding of both loaded and empty holds.

The specified design load limits for the cargo holds are to be represented by loading conditions defined by the designer in the Loading Manual.

Non homogeneous part loading conditions associated with multiport loading and unloading operations for homogeneous loading conditions need not be considered according to these requirements.

Holds carrying packed cargoes shall be considered as empty holds for this application. Unless the ship is intended to carry, in non homogeneous conditions, only iron ore or cargo having bulk density equal or greater than 1,78 t/m³, the maximum mass of cargo which may be carried in the hold shall also be considered to fill that hold up to the upper deck level at centreline.

2.2 Bulkhead corrugation flooding head.

Flooding head h_f (refer to Fig. 2.2) is the distance, in m, measured vertically, with the ship in the upright position, from the calculation point to a level located at a distance d_f , in m, from the base line equal to:

- .1 in general D for the foremost transverse corrugated bulkhead;
- $0,9D$ for the other bulkheads.

Where the ship shall carry cargoes having bulk density less than 1,78 t/m³ in non homogeneous loading conditions, the following values can be assumed:

- $0,95D$ for the foremost transverse corrugated bulkhead;
- $0,85D$ for the other bulkheads;

- .2 for ships less than 50000 t deadweight with Type B freeboard
- $0,95D$ for the foremost transverse corrugated bulkhead;
- $0,85D$ for the other bulkheads.

Where the ship is to carry cargoes having bulk density less than $1,78 \text{ t/m}^3$ in non homogeneous loading conditions, the following values can be assumed:

- 0,9D for the foremost transverse corrugated bulkhead;
- 0,8D for the other bulkheads.

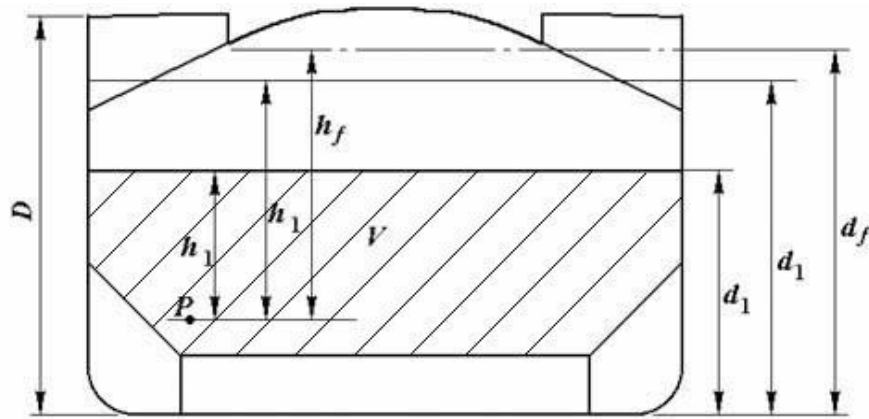

Fig.2.2:

V – volume of cargo, in m^3 ; P – calculation point; D – distance, in m, from the base line to the freeboard deck at side amidships

2.3 Pressure in the non-flooded bulk cargo loaded holds.

At each point of the bulkhead, the pressure p_c , in kN/m^2 , shall be determined by the formula:

$$p_c = \rho_c g h_1 \text{tg}^2 \gamma,$$

where: ρ_c – bulk cargo density, in t/m^3 ;

g – gravity acceleration equal to $9,81 \text{ m/s}^2$;

h_1 – vertical distance, in m, from the calculation point to horizontal plane corresponding to the level height of the cargo (refer to Fig. 2.2), located at a distance d_1 , in m, from the base line;

$$\gamma = 45^\circ - (\varphi / 2);$$

where: φ – angle of repose of the cargo, in deg., that may generally be taken as 35° for iron ore and 25° for cement.

The force F_c , in kN, acting on a corrugation shall be determined by the formula:

$$F_c = \rho_c g s_1 \frac{(d_1 - h_{DB} - h_{LS})^2}{2} \text{tg}^2 \gamma,$$

where: s_1 – spacing of corrugations, in m (refer to Fig. 2.3);

h_{LS} – mean height of the lower stool, in m, from the inner bottom;

h_{DB} – height of the double bottom, in m.

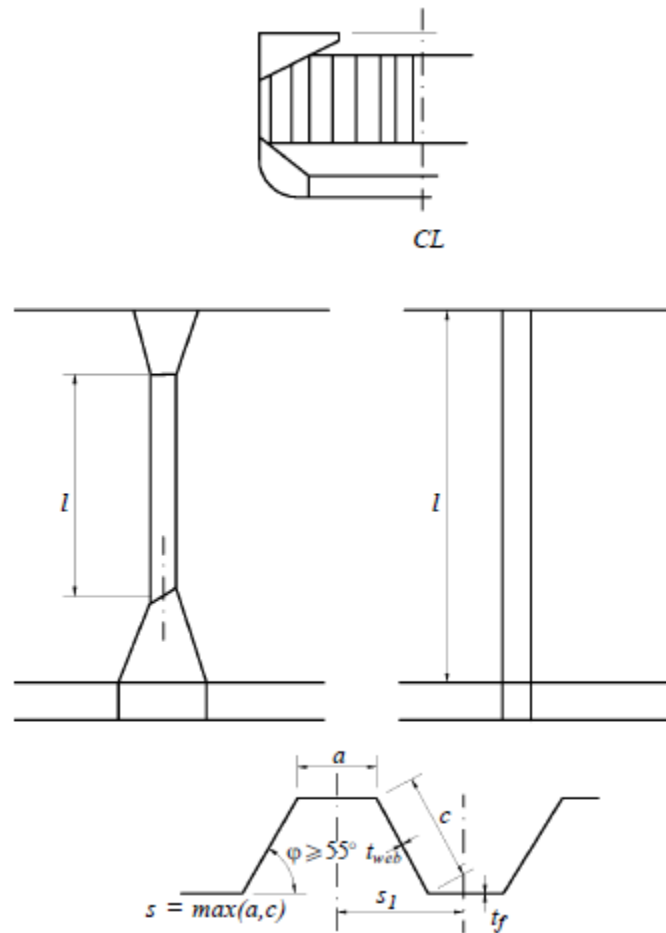

Fig. 2.3:

n – neutral axis of the corrugations;
 t_f – net flange thickness, in mm;
 t_{web} – corrugation web thickness.

2.4 Pressure in the flooded holds.

2.4.1 Bulk cargo holds.

Two cases shall be considered, depending on the values of d_1 and d_f :

.1 $d_1 \leq d_f$.

At each point of the bulkhead located at a distance between d_1 and d_f from the base line, the pressure $p_{c,f}$, in kN/m^2 , shall be determined by the formula

$$p_{c,f} = \rho g h_f,$$

where: ρ – sea water density, in t/m^3 ;

for g refer to 2.3;

h_f – flooding head (as defined in 2.2).

At each point of the bulkhead located at a distance lower than d_1 from the base line, the pressure $p_{c,f}$, in kN/m^2 , shall be determined by the formula

$$p_{c,f} = \rho g h_f + [\rho_c - \rho (1 - \text{perm})] g h_1 \text{tg}^2 \gamma,$$

where for ρ_c , g , h_1 , γ – refer to 2.3;

perm – permeability of cargo, to be taken as 0,3 for ore (corresponding bulk cargo density for iron ore may generally be taken as 3,0 t/m³), coal cargoes and for cement (corresponding bulk cargo density for cement may generally be taken as 1,3 t/m³).

The force $F_{c,f}$, in kN, acting on a corrugation shall be determined by the formula

$$F_{c,f} = s_1 \left[\rho g \frac{(d_f - d_1)^2}{2} + \frac{\rho g (d_f - d_1) + (p_{c,f})_{le}}{2} (d_1 - h_{DB} - h_{LS}) \right],$$

where for s_1 , g , d_1 , h_{DB} , h_{LS} – refer to 2.3;

for d_f – refer to 2.2;

$(p_{c,f})_{le}$ – pressure at the lower end of the corrugation, in kN/m².

.2 $d_1 > d_f$.

At each point of the bulkhead located at a distance between d_1 and d_f , from the base line, the pressure $p_{c,f}$, in kN/m², shall be determined by the formula

$$p_{c,f} = \rho_c g h_1 \tan^2 \gamma,$$

where for ρ_c , g , h_1 , γ – refer to 2.3.

At each point of the bulkhead located at a distance lower than d_f , from the base line, the pressure p_c , in kN/m², shall be determined by the formula

$$p_{c,f} = \rho g h_f + [\rho_c h_1 - \rho (1 - \text{perm}) h_f] g \tan^2 \gamma,$$

where for ρ , h_f , perm – refer to 2.4.1.1;

for ρ_c , g , h_1 , γ – refer to 2.3.

The force $F_{c,f}$, in kN, acting on a corrugation shall be determined by the formula

$$F_{c,f} = s_1 \left[\rho g \frac{(d_1 - d_f)^2}{2} \tan^2 \gamma + \frac{\rho_c g (d_1 - d_f) \tan^2 \gamma + (p_{c,f})_{le}}{2} (d_f - h_{DB} - h_{LS}) \right],$$

where for s_1 , ρ_c , g , d_1 , γ , h_{DB} , h_{LS} – refer to 2.3;

for d_f – refer to 2.2;

$(p_{c,f})_{le}$ – = pressure at the lower end of the corrugation, in kN/m².

2.4.2 Pressure in empty holds due to flooding water alone.

At each point of the bulkhead, the hydrostatic pressure p_f induced by the flooding head h_f shall be considered. The force F_f , in kN, acting on a corrugation shall be determined by the formula

$$F_f = s_1 \rho g \frac{(d_f - h_{DB} - h_{LS})^2}{2},$$

where for s_1 , g , h_{DB} , h_{LS} – refer to 2.3;

for ρ – refer to 2.4.1.1;

for d_f – refer to 2.2.

2.5 Resultant pressure and force.

2.5.1 Homogeneous loading conditions.

At each point of the bulkhead structures, the resultant pressure p , in kN/m², to be considered for the scantlings of the bulkhead shall be determined by the formula

$$p = p_{c,f} - 0,8p_c .$$

The resultant force F , in kN, acting on a corrugation shall be determined by the formula

$$F = F_{c,f} - 0,8F_c .$$

2.5.2 Non homogeneous loading conditions.

At each point of the bulkhead structures, the resultant pressure p , in kN/m², to be considered for the scantlings of the bulkhead shall be determined by the formula

$$p = p_{c,f} .$$

The resultant force F , in kN, acting on a corrugation, shall be determined by the formula

$$F = F_{c,f} .$$

3. BENDING MOMENT AND SHEAR FORCE IN THE BULKHEAD CORRUGATIONS

The bending moment M and the shear force Q in the bulkhead corrugations shall be determined by the formulae given in 3.1 and 3.2. The M and Q values shall be used for the checks in 4.5.

3.1 BENDING MOMENT.

The design bending moment M , in kN/m, for the bulkhead corrugations shall be determined by the formula

$$M = Fl/8,$$

where: F – resultant force, in kN (refer to 2.5);

l – span of corrugation, in m (refer to Figs. 2.3 and 3.1).

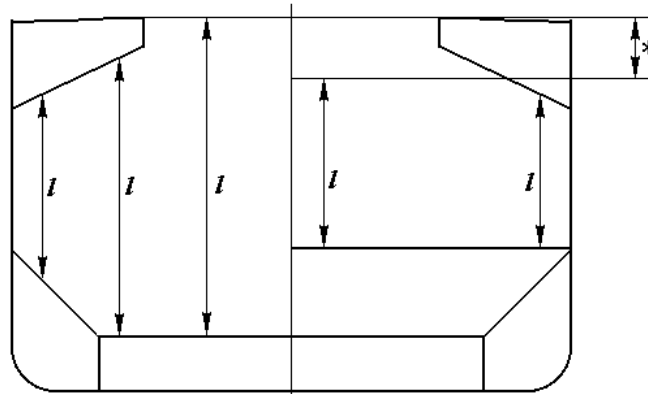

Fig.3.1:

l – span of corrugation;

* – for the definition of l , the internal end of the upper stool shall not be taken more than a distance from the deck at the centerline equal to:

3 times the depth of corrugations, in general;

2 times the depth of corrugations, rectangular stool.

3.2 Shear force.

The shear force Q , in kN, at the lower end of the bulkhead corrugations shall be determined by the formula

$$Q = 0,8F ,$$

where for F , refer to 2.5.

4. STRENGTH CRITERIA

4.1 General.

4.1.1 The following criteria are applicable to transverse bulkheads with vertical corrugations (refer to Fig. 2.3).

For ships of 190 m in length and above, these bulkheads shall be fitted with a lower stool, and generally with an upper stool below deck.

For smaller ships, corrugations may extend from inner bottom to deck; if the stool is fitted, it shall comply with the requirements of this Chapter.

The corrugation angle ϕ shown in Fig. 2.3 shall not be less than 55° .

Requirements for local net plate thickness are given in 4.7. In addition, the criteria as given in 4.2 and 4.5 shall be complied with.

The thickness of the lower part of corrugations determined in accordance with 4.2 and 4.3 shall be maintained for a distance from the inner bottom (if no lower stool is fitted) or the top of the lower stool not less than $0,15l$.

The thickness of the middle part of corrugations determined in accordance with 4.2 and 4.4, shall be maintained to a distance from the deck (if no upper stool is fitted) or the bottom of the upper stool not greater than $0,3l$.

The section modulus of the corrugation in the remaining upper part of the bulkhead shall not be less than 75 % of that required for the middle part, corrected for different yield stresses.

4.1.2 Lower stool.

The height of the lower stool is generally shall be not less than 3 times the depth of the corrugations.

The thickness and material of the stool top plate shall not be less than those required for the bulkhead plating as specified in 4.1.1. The thickness and material of the upper portion of vertical or sloping stool side plating within the depth equal to the corrugation flange width from the stool top shall not be less than the required flange plate thickness and material to meet the bulkhead stiffness requirement at lower end of corrugation. The thickness of the stool side plating and the section modulus of the stool side stiffeners shall not be less than those required in 3.3 of this Part on the basis of the load model in Section 2 of this Appendix. The ends of stool side vertical stiffeners shall be attached to brackets at the upper and lower ends of the stool.

The distance from the edge of the stool top plate to the surface of the corrugation shall be in accordance with Fig. 4.1.2. The stool bottom shall be installed in line with double bottom floors and shall have a width not less than 2,5 times the mean depth of the corrugation. The stool shall be fitted with diaphragms in line with the longitudinal double bottom girders for effective support of the corrugated bulkhead. Scallops in the brackets and diaphragms in way of the connections to the stool top plate shall be avoided.

Where corrugations are cut at the lower stool, corrugated bulkhead plating shall be connected to the stool top plate by full penetration welds. The stool side plating shall be connected to the stool top plate and the inner bottom plating by either full penetration or deep penetration welds. The supporting floors shall be connected to the inner bottom by either full penetration or deep penetration welds.

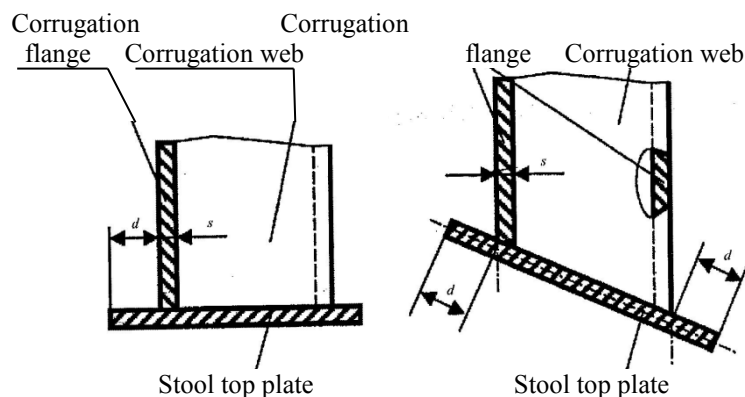

Fig. 4.1.2

s – as-built flange thickness; $d \geq s$

4.1.3 Upper stool.

The upper stool, where fitted, shall have a height generally between 2 and 3 times the depth of corrugations. Rectangular stools shall have a height generally equal to 2 times the depth of corrugations, measured from the deck level and at hatch side girder. The upper stool shall be properly supported by girders or deep brackets between the adjacent hatch-end beams.

The width of the stool bottom plate shall generally be the same as that of the lower stool top plate. The stool top of non rectangular stools shall have a width not less than 2 times the depth of corrugations.

The thickness and material of the stool bottom plate shall be the same as those of the bulkhead plating below.

The thickness of the lower portion of stool side plating shall not be less than 80 % of that required for the upper part of the bulkhead plating where the same material is used. The thickness of the stool side plating and the section modulus of the stool side stiffeners shall not be less than those required by the Register on the basis of the load model in Section 2 of this Appendix.

The ends of stool side stiffeners shall be attached to brackets at upper and lower end of the stool. Diaphragms shall be fitted inside the stool in line with and effectively attached to longitudinal deck girders extending to the hatch end coaming girders for effective support of the corrugated bulkhead. Scallops in the brackets and diaphragms in way of the connection to the stool bottom plate shall be avoided.

4.1.4 Alignment.

At deck, if no stool is fitted, two transverse reinforced beams shall be fitted in line with the corrugation flanges.

At bottom, if no stool is fitted, the corrugation flanges shall be in line with the supporting floors.

Corrugated bulkhead plating shall be connected to the inner bottom plating by full penetration welds. The plating of supporting floors shall be connected to the inner bottom by either full penetration or deep penetration welds.

The thickness and material properties of the supporting floors shall be at least equal to those provided for the corrugation flanges. Moreover, the cut-outs for connections of the inner bottom longitudinals to double bottom floors shall be closed by collar plates. The supporting floors shall be connected to each other by suitably designed shear plates complying with the requirements of 3.3 of this Part.

Stool side plating shall align with the corrugation flanges and stool side vertical stiffeners and their brackets in lower stool shall align with the inner bottom longitudinals to provide appropriate load transmission between these stiffening members. Stool side plating shall not be knuckled anywhere between the inner bottom plating and the stool top.

4.2 Bending capacity and shear stress τ .

The bending capacity shall comply with the following relationship:

$$[M \cdot 10^3 / (0,5 \cdot Z_{le} \cdot \sigma_{a,le} + Z_m \cdot \sigma_{a,m})] \leq 0,95,$$

where: M – bending moment, in kN·m (refer to 3.1);

Z_{le} – section modulus of one half pitch corrugation, in cm³, at the lower end of corrugations, to be calculated according to 4.3;

Z_m – section modulus of one half pitch corrugation, in cm³, at the mid-span of corrugations, to be calculated according to 4.4;

$\sigma_{a,le}$ – allowable stress, in N/mm², as given in 4.5, for the lower end of corrugations;

$\sigma_{a,m}$ – allowable stress, in N/mm², as given in 4.5, for the midspan of corrugations.

In no case Z_m shall be taken greater than the lesser of $1,15Z_{le}$ and $1,15Z'_{le}$ for calculation of the bending capacity, Z'_{le} being defined below.

In case shedders plates are fitted which:

are not knuckled;

are welded to the corrugations and the top of the lower stool by one side penetration welds or equivalent;

are fitted with a minimum slope of 45° and their lower edge is in line with the stool side plating;

have thicknesses not less than 75 % of that provided by the corrugation flange;

and material properties at least equal to those provided by the flanges; or gasket plates are fitted which:

are in combination with shedder plates having thickness, material properties and welded connections in accordance with the above requirements; have a height not less than half of the flange width;

are fitted in line with the stool side plating;

are generally welded to the top of the lower stool by full penetration welds, and to the corrugations and shedder plates by one side penetration welds or equivalent;

have thickness and material properties at least equal to those provided for the flanges, the section modulus Z_{le} , in cm^3 , shall be taken not larger than the value Z'_{le} , in cm^3 , to be determined by the formula

$$Z'_{le} = Z_g + [(Qh_g - 0,5h_g^2s_1p) / \sigma_a] 10^3,$$

where: Z_g – section modulus of one half pitch corrugation, in cm^3 , according to 4.4, in way of the upper end of shedder or gusset plates, as applicable;

Q – shear force, in kN (refer to 3.2);

h_g – height, in m, of shedders or gusset plates (refer to Figs. 4.2-1, 4.2-2, 4.2-3 and 4.2-4);

for s_1 – refer to 2.3;

p – resultant pressure, in kN/m^2 , as defined in 2.5, calculated in way of the middle of the shedders or gusset plates, as applicable;

σ_a – allowable stress, in N/mm^2 , in accordance with 4.5.

Stresses are obtained by dividing the shear force Q by the shear area. The shear area shall be reduced in order to account for possible non-perpendicularity between the corrugation webs and flanges. In general, the reduced shear area may be obtained by multiplying the web sectional area by $(\sin \varphi)$, φ being the angle between the web and the flange. When calculating the section modulus and the shear area, the net plate thicknesses shall be used. The section modulus of corrugations shall be calculated on the basis of the following requirements given in 4.3 and 4.4.

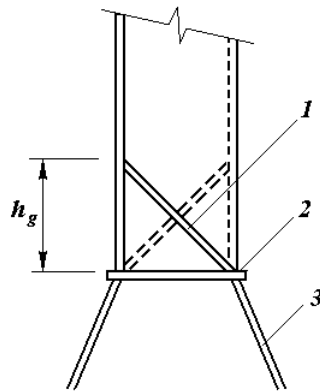

Fig. 4.2-1

Symmetric shedder plates:
1 – shedder plate;
2 – top of the lower stool
3 – vertical or sloping stool
side plating

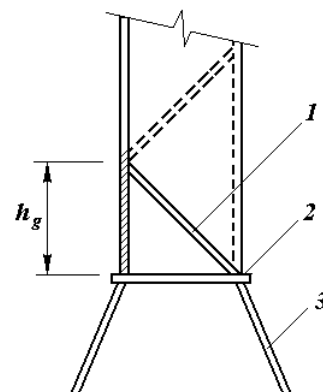

Fig. 4.2-2

Asymmetric shedder plates:
1 – shedder plate;
2 – top of the lower stool
3 – vertical or sloping stool
side plating

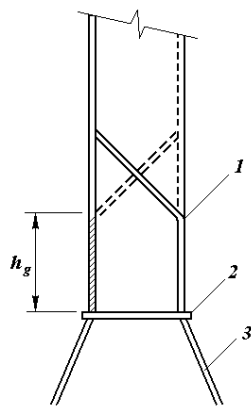

Fig. 4.2-3

Symmetric gasket/shedder plates:

- 1 – gasket/shedder plate;
- 2 – top of the lower stool
- 3 – vertical or sloping stool side plating

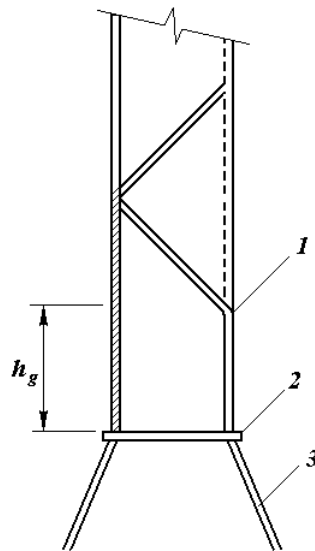

Fig. 4.2-4

Asymmetric gasket/shedder plates:

- 1 – gasket/shedder plate;
- 2 – top of the lower stool
- 3 – vertical or sloping stool side plating

4.3 Section modulus at the lower end of corrugations.

4.3.1 The section modulus shall be calculated with the compression flange having an effective flange width, b_{ef} , not larger than as given in 4.6.

If the corrugation webs are not supported by local brackets below the stool top (or below the inner bottom) in the lower part, the section modulus of the corrugations shall be calculated considering the corrugation webs 30 % effective.

4.3.2 Provided that effective shedder plates, as defined in 4.2, are fitted (refer to Figs. 4.2-1 and 4.2-2), when calculating the section modulus of corrugations at the lower end, the area of flange plates, in cm^2 , may be increased by:

$$\left(2,5a\sqrt{t_f t_{sh}}\right), \text{ not to be taken greater than } 2,5at_f,$$

where: a – width of the corrugation flange, in m (refer to Fig. 2.3);

t_{sh} – net shedder plate thickness, in mm;

t_f – net flange thickness, in mm.

4.3.3 Provided that effective gusset plates, as defined in 4.2, are fitted (refer to Figs. 4.2-3 and 4.2-4), when calculating the section modulus of corrugations at the lower end, the area of flange plates, in cm^2 , may be increased by

$$\left(7h_g t_f\right),$$

where h_g – height of gusset plate, in m (refer to Figs 4.2-3 and 4.2-4), with $h_g \leq (10/7)s_{gu}$;

s_{gu} – width of the gusset plates, in m;

t_f – net flange thickness, in mm, based on the as built condition.

4.3.4 If the corrugation webs are welded to a sloping stool top plate which have an angle not less than 45° with the horizontal plane, the section modulus of the corrugations may be calculated considering the corrugation webs fully effective. In case effective gusset plates are fitted, when calculating the section modulus of corrugations the area of flange plates may be increased as specified in 4.3.3. No credit can be given to shedder plates only.

For angles less than 45°, the effectiveness of the web may be obtained by linear interpolation between 30 % for 08 and 100 % for 45°.

4.4 Modulus of corrugations at cross-sections other than the lower end.

The section modulus shall be calculated with the corrugation webs considered effective and the compression flange having an effective flange width b_{ef} , not larger than as given in 4.6.1.

4.5 Allowable stress check.

The normal and shear stresses σ and τ shall not exceed the allowable values σ_a and τ_a , in N/mm², to be determined by the formulae:

$$\begin{aligned}\sigma_a &= R_{eH}; \\ \tau_a &= 0,5R_{eH},\end{aligned}$$

where: R_{eH} – the minimum upper yield stress of the material, in N/mm².

4.6 Effective compression flange width and shear buckling check.

4.6.1 Effective width of the compression flange of corrugations.

The effective width b_{ef} in m, of the corrugation flange shall be determined by the formula

$$b_{ef} = C_e a,$$

where: $C_e = 2,25 / \beta - 1,25 / \beta^2$, for $\beta > 1,25$;

$C_e = 1,0$, for $\beta \leq 1,25$;

$$\beta = \frac{a}{t_f} \sqrt{R_{eH} / E} \cdot 10^3;$$

t_f – net flange thickness, in mm;

a – width of the corrugation flange, in m (refer to Fig. 2.3);

for R_{eH} – refer to 4.5;

E – modulus of elasticity of the material, in N/mm², to be assumed equal to 2,06/10⁵ for steel.

4.6.2 Shear.

The buckling check shall performed for the web plates at the corrugation end.

The shear stress shall not exceed the critical value τ_c , in N/mm², to be determined by the formulae:

$$\begin{aligned}\tau_c &= \tau_e \quad \text{when} \quad \tau_e \leq \tau_f/2; \\ \tau_c &= \tau_f (1 - 0,25\tau_f / \tau_e) \quad \text{when} \quad \tau_e > \tau_f/2,\end{aligned}$$

where: $\tau_f = R_{eH} / \sqrt{3}$;

for R_{eH} – refer to 4.5;

$$\tau_e = 0,9 k_t E \left(\frac{t}{1000c} \right)^2 \quad \text{in N/mm}^2;$$

$k_t = 6,34$;

E – modulus of elasticity of material as given in 4.6.1;

t – net thickness of corrugation web, in mm;

c – width of corrugation web, in mm (refer to Fig. 2.3).

4.7 Local net plate thickness.

The bulkhead local net plate thickness t , in mm, shall be determined by the formula

$$t = 14,9 s_w \sqrt{1,05 p / R_{eH}},$$

where s_w = plate width, in m, to be taken equal to the width of the corrugation flange or web, whichever is greater (refer to Fig. 2.3);

p = resultant pressure, in kN/m^2 , as defined in 2.5, at the bottom of each strake of plating; in all cases, the net thickness of the lowest strake shall be determined using the resultant pressure at the top of the lower stool, or at the inner bottom, if no lower stool is fitted or at the top of shedders, if shedder or gusset/shedder plates are fitted;
for R_{eH} – refer to 4.5.

For built-up corrugation bulkheads, when the thicknesses of the flange and web are different, the net thickness of the narrower plating shall be not less than t_n , in mm, determined by the formula

$$t_n = 14,9s_n\sqrt{1,05p / R_{eH}} ,$$

where: s_n – width of the narrower plating, in m.

The net thickness of the wider plating, in mm, shall not be taken less than the maximum of the following:

$$t_w = 14,9s_w\sqrt{1,05p / R_{eH}} ;$$

$$t_w = 20,98s_w\sqrt{1,05p / R_{eH} - t_{np}^2},$$

where: $t_{np} \leq$ actual net thickness of the narrower plating or shall not be greater than $14,9s_w\sqrt{1,05p / R_{eH}}$ whichever is less.

5. LOCAL DETAILS

As applicable, the design of local details shall comply with the Register requirements for the purpose of transferring the corrugated bulkhead forces and moments to the boundary structures, in particular to the double bottom and cross-deck structures.

In particular, the thickness and stiffening of effective gusset and shedder plates, as defined in 4.3, shall comply with the requirements, on the basis of the load model in Section 2 of this Appendix. Unless otherwise stated, weld connections or materials shall be dimensioned and selected in accordance with 1.7 of this Part.

6. CORROSION ADDITION AND STEEL RENEWAL

The corrosion addition t_s shall be taken equal to 3,5 mm.

Steel renewal is required where the gauged thickness is less than $t_{net}+0,5$ mm.

Where the gauged thickness is within the range $t_{net}+0,5$ mm and $t_{net}+1$ mm, coating (applied in accordance with the coating manufacturer's requirements) or annual gauging may be adopted as an alternative to steel renewal.

APPENDIX 4

EVALUATION OF ALLOWABLE HOLD LOADING FOR NON-CSR BULK CARRIERS CONSIDERING HOLD FLOODING

1. APPLICATION AND DEFINITIONS

The loading in each hold shall not exceed the allowable hold loading in flooded condition, calculated as per Section 4 of this Appendix, using the loads given in Section 2 and the shear capacity of the double bottom given in Section 3.

In no case the allowable hold loading, considering flooding, shall be greater than the design hold loading in the intact condition.

2. LOADING MODEL

2.1 General.

The loads to be considered as acting on the double bottom are those given by the external sea pressures and the combination of the cargo loads with those induced by the flooding of the hold which the double bottom belongs to.

The most severe combinations of cargo induced loads and flooding loads shall be used, depending on the loading conditions included in the Loading Manual:

- homogeneous loading conditions;
- non homogeneous loading conditions;
- packed cargo conditions (such as steel mill products).

For each loading condition, the maximum bulk cargo density to be carried shall be considered in calculating the allowable hold loading limit.

2.2 INNER BOTTOM FLOODING HEAD.

Flooding head h_f (refer to Fig. 2.2) is the distance, in m, measured vertically with the ship in the upright position, from the inner bottom to a level located at a distance d_f , in m, from the base line equal to:

- in general D for the foremost hold;
- $0,9D$ for the other holds;
- for ships less than 50000 t deadweight with Type **B** freeboard
- $0,95D$ for the foremost hold;
- $0,85D$ for the other holds.

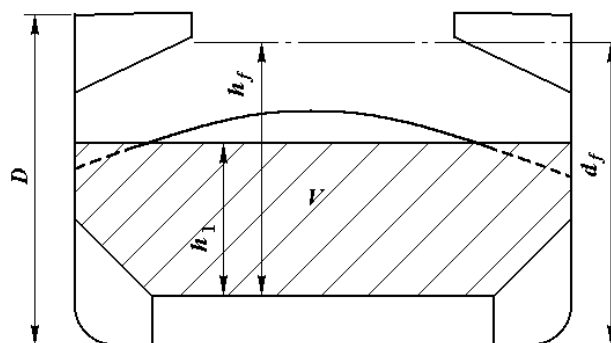

Fig. 2.2:

V – volume of cargo;

D – distance, in m, from the base line to the freeboard deck at side amidship

3. SHEAR CAPACITY OF THE DOUBLE BOTTOM

3.1 The shear capacity.

The shear capacity C of double bottom shall be defined as the sum of the shear force at each end of:

.1 all floors adjacent to both hoppers, less one half of the shear forces of the two floors adjacent to each stool, or transverse bulkhead if no stool is fitted (refer to Fig. 3.1.1);

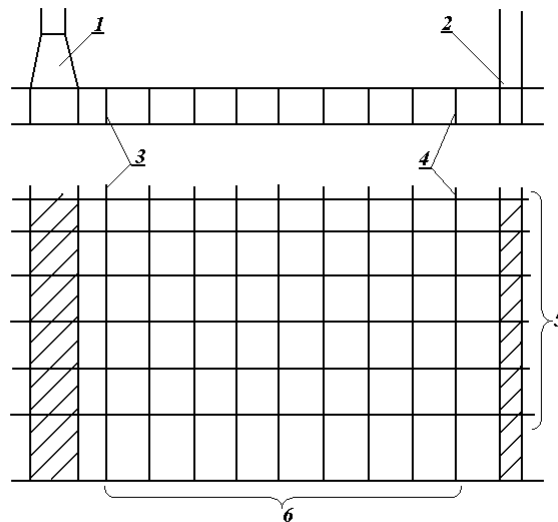

Fig. 3.1.1:

1 - lower stool; 2 - transverse bulkhead; 3 - floor adjacent to the stool; 4 - floor adjacent to transverse bulkhead; 5 - girders; 6 - floors

.2 all double bottom girders adjacent to both stools, or transverse bulkheads if no stool is fitted.

Where in the end holds, girders or floors run out and are not directly attached to the boundary stool or hopper girder, their shear force shall be evaluated for the one end only.

Floors and girders to be considered are those inside the hold boundaries formed by the hoppers and stools (or transverse bulkheads if no stool is fitted). The hopper side girders and the floors directly below the connection of the bulkhead stools (or transverse bulkheads if no stool is fitted) to the inner bottom shall not be included.

When the geometry and/or the structural arrangement of the double bottom are such to make the above assumptions inadequate, the shear capacity C of double bottom shall be calculated in compliance with the requirements of 3.3 of this Part or according to the Strength Norms for Sea-Going Ships.

In calculating the shear force, the net thickness of floors and girders is to be used. The net thickness t_{net} , in mm, shall be determined by the formula

$$t_{net} = t - 2,5,$$

where: t – thickness of floors and girders, in mm.

3.2 Floor shear force.

The floor shear force in way of the floor panel adjacent to hoppers S_{f1} , in kN, and the floor shear force in way of the openings in the outmost bay (i.e. that bay which is closer to hopper) S_{f2} , in kN, shall be determined by the formulae:

$$S_{f1} = A_f \tau_a \cdot 10^{-3} / \eta_1;$$

$$S_{f2} = A_{f,h} \tau_a \cdot 10^{-3} / \eta_2,$$

where: A_f – sectional area of the floor panel adjacent to hoppers, in mm²;

$A_{f,h}$ – net sectional area of the floor panels in way of the openings in the outmost bay (i.e. that bay which is closer to hopper), in mm²;

τ_a – allowable shear stress, in N/mm², to be taken equal to the lesser of $\tau_a = \frac{162R_{eH}^{0,6}}{(s/t_{net})^{0,8}}$ and $R_{eH} / \sqrt{3}$

For floors attached to the stools or transverse bulkheads, τ_a may be taken:

$$R_{eH} / \sqrt{3},$$

where: R_{eH} – minimum upper yield stress of the material, in N/mm² ;

s – spacing of stiffening members of panel under consideration, in mm;

$\eta_1 = 1,10$;

$\eta_2 = 1,20$; whereas η_2 may be reduced down to 1,10 where appropriate reinforcements are fitted and requirement calculation did and presented to Registry for assesment.

3.3 Girder shear force.

The girder shear force in way of the girder panel adjacent to stools (or transverse bulkheads, if no stool is fitted) S_{g1} , in kN, and the girder shear force in way of the largest opening in the outmost bay (i.e. that bay which is closer to stool, or transverse bulkhead, if no stool is fitted) S_{g2} , in kN, shall be determined by the formulae:

$$S_{g1} = A_g \tau_a \cdot 10^{-3} / \eta_1 ;$$

$$S_{g2} = A_{g,h} \tau_a \cdot 10^{-3} / \eta_2 ,$$

where: A_g – minimum sectional area of the girder panel adjacent to stools (or transverse bulkheads, if no stool is fitted), in mm²;

$A_{g,h}$ – net sectional area of the girder panel in way of the largest opening in the outmost bay (i.e. that bay which is closer to stool, or transverse bulkhead, if no stool is fitted), in mm²;

τ_a – allowable shear stress, in N/mm², as specified in 3.2;

$\eta_1 = 1,10$;

$\eta_2 = 1,15$; whereas η_2 may be reduced down to 1,10 where appropriate reinforcements are fitted and requirement calculation did and presented to Registry for assesment.

4. ALLOWABLE HOLD LOADING

The allowable hold loading W , in t, shall be determined by the formula

$$W = \rho_c V / F,$$

where: $F = 1,10$ – in general;

$F = 1,05$ – for steel mill products;

ρ_c – cargo density for bulk cargoes, in t/m³ (refer to 2.1). For steel products ρ_c shall be taken as the density of steel;

V – volume, in m³, occupied by cargo at a level h_1

$h_1 = X / (\rho_c g)$.

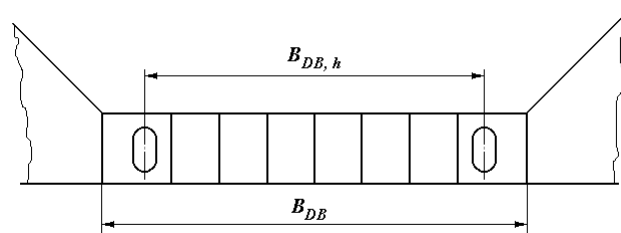

Fig.4

For bulk cargoes, X shall be taken as the lesser of X_1 and X_2 determined by the formulae:

$$X_1 = \frac{Z + \rho g(E - h_f)}{1 + \rho / \rho_c (\text{perm} - 1)};$$

$$X_2 = Z + \rho g(E - h_f \text{perm}),$$

where: $X = X_1$ – for steel products, using $\text{perm} = 0$;

ρ – sea water density, in t/m^3 ;

g – $9,81 \text{ m/s}^2$, gravity acceleration;

$E = d_f - 0,1D$ – ship immersion, in m, for flooded hold condition;

for d_f, D – refer to **2.2**;

h_f – flooding head, in m (refer to **2.2**);

perm – cargo permeability (i.e. the ratio between the voids within the cargo mass and the volume occupied by the cargo), it needs not be taken greater than 0,3;

Z = the lesser of Z_1 or Z_2 whereas:

$$Z_1 = \frac{C_h}{A_{DB,h}};$$

$$Z_2 = \frac{C_e}{A_{DB,e}},$$

where: C_h – shear capacity of the double bottom, in kN, as defined in Section **3** of this Appendix, considering, for each floor, the lesser of the shear forces S_{f1} and S_{f2} (refer to **3.2**) and for each girder, the lesser of the shear forces S_{g1} and S_{g2} (refer to **3.3**);

C_e – shear capacity of the double bottom, in kN, as defined in Section **3** of this Appendix, considering, for each floor, the shear force S_{f1} (refer to **3.2**), and, for each girder, the lesser of the shear forces S_{g1} and S_{g2} shall be determined according to **3.3**;

$$A_{DB,h} = \sum_{i=1}^{i=n} S_i B_{DB,i};$$

$$A_{DB,e} = \sum_{i=1}^{i=n} S_i (B_{DB} - s_1),$$

where: n – number of floors between stools (or transverse bulkheads, if no stool is fitted);

S_i – space of i -th floor, in m; $B_{DB,i} = B_{DB} - s_1$ – for floors whose shear force is determined by S_{f1} (refer to **3.2**);

$B_{DB,i} = B_{DB,h}$ – for floors whose shear force is determined by S_{f2} (refer to **3.2**);

B_{DB} – breadth of double bottom between hoppers, in m (refer to Fig. 4);

$B_{DB,h}$ – distance between the two considered openings, in m (refer to Fig. 4);

s_1 – spacing of double bottom longitudinals adjacent to hoppers, in m.



Veritas Register of Shipping LTD

Rules for Classification and Construction of Sea Going Ships
Part II
Hull

Veritas Register of Shipping LTD
Office №19, Tower "A", Chavchavadze Str. №5,
Batumi 6000, Georgia
Tel.: +995 422 227427
E-mail: headoffice@vrsclass.com